

TOSHIBA BiCD Integrated Circuit Silicon Monolithic

TB67S111PG

Full parallel controlled solenoid driver / unipolar motor driver

The TB67S111PG is a solenoid driver /unipolar motor driver for full parallel input.

Using the BiCD process, the power supply voltage of 45 V, the output voltage of 80 V, and the output current of 1.5 A/ch (absolute maximum rating) are realized.

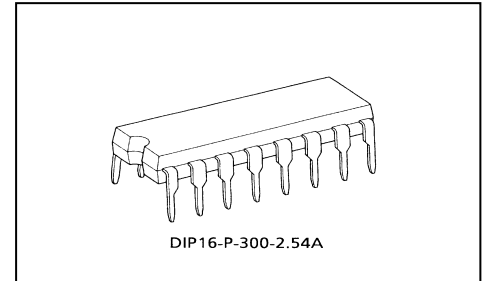

Weight: 1.11 g (typ.)

Features

- BiCD integrated circuit silicon monolithic.
- Capable of driving up to four solenoids simultaneously. (4-ch sink driver)
- Capable of driving a unipolar stepping motor with a single chip.
- Built-in over current detection (automatic return / time control) at each output.
- Built-in thermal shutdown detection (automatic return / time control), which detects errors of the whole device.
- Output (ERR) pin for thermal shutdown signal.
- Built-in output MOSFET for low ON resistance (0.25 Ω (typ.)).
- High voltage and large current (as for specifications, please refer to the absolute maximum ratings and operation ranges).
- Built-in abnormal detection functions (thermal shutdown detection (TSD), over current detection (ISD), and undervoltage detection (POR)).
- Built-in VCC regulator for internal circuit control, capable of being used as the pull-up point of an error output function.

Note: Please be careful about the thermal conditions during use.

Pin Assignment

(Top View)

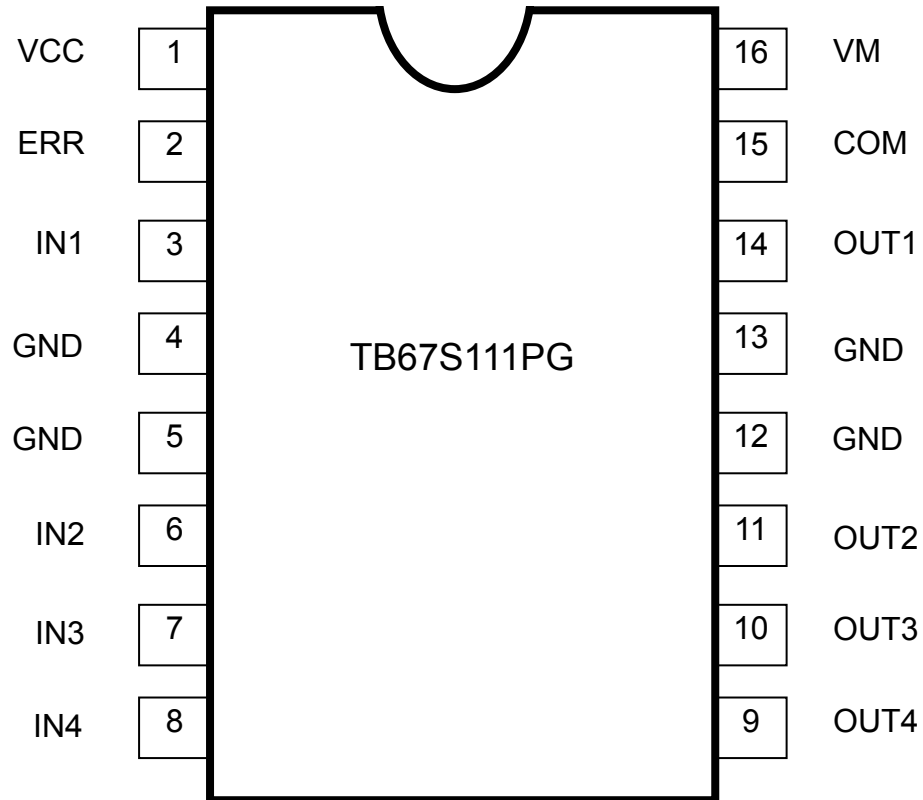

Block Diagram

(Top View)

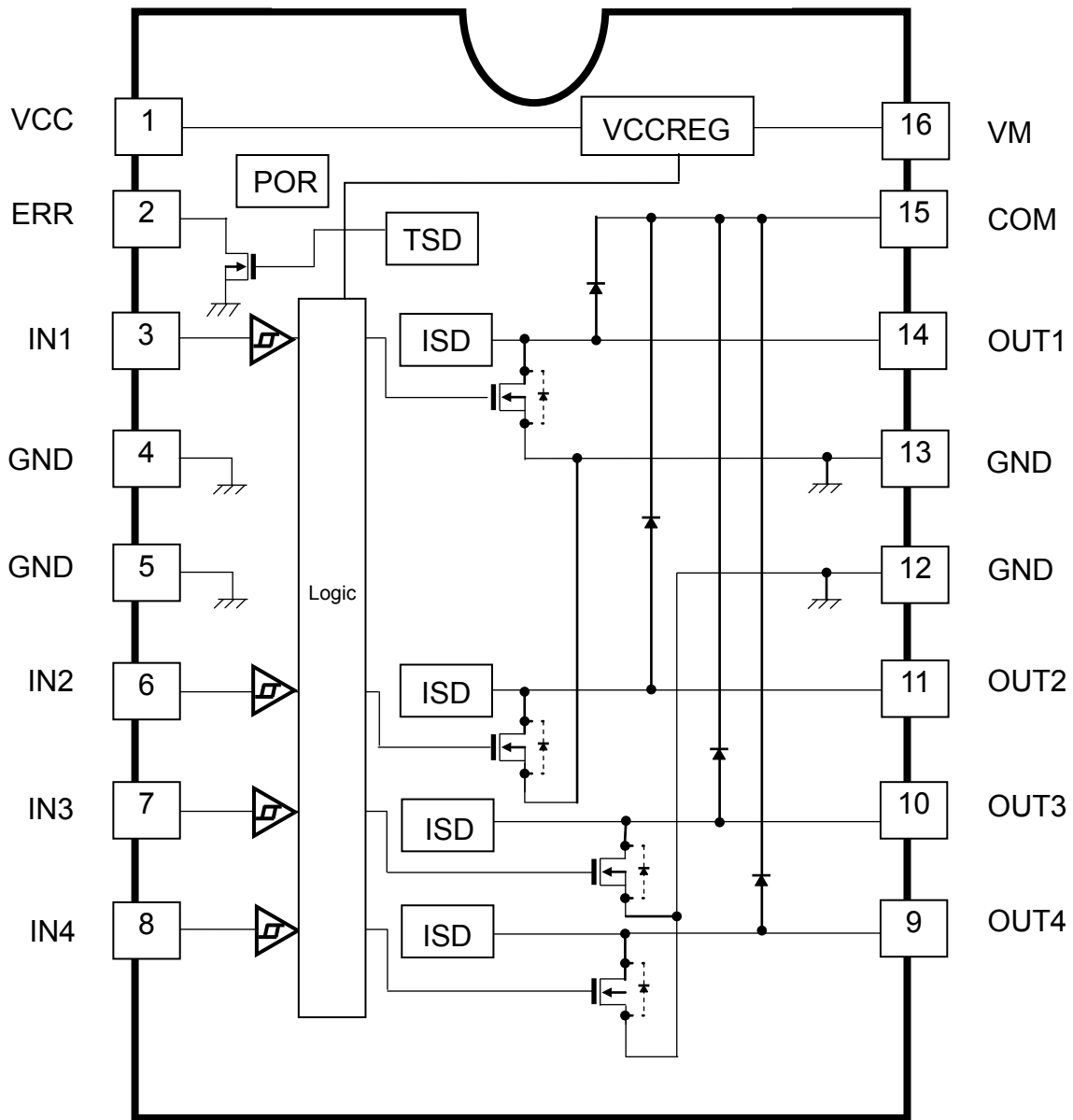

Some of the functional blocks, circuits, or constants in the block diagram may be omitted or simplified for explanatory purposes.

IC considerations

All the grounding wires of the device must run on the solder mask on the PCB and be externally terminated at only one point. Also, a grounding method should be considered for efficient heat dissipation.

Careful attention should be paid to the layout of the output, VM and GND traces, to avoid short circuits across output pins or to the power supply or ground. If such a short circuit occurs, the device may be permanently damaged. Also, the utmost care should be taken for pattern designing and implementation of the device since it has power supply pins (VM, OUT, GND, etc.) through which a particularly large current may run. If these pins are wired incorrectly, an operation error may occur or the device may be destroyed.

The logic input pins must also be wired correctly. Otherwise, the device may be damaged owing to a current running through the IC that is larger than the specified current. Careful attention should be paid for IC pattern design and mounting method.

Pin Function Description

Function description (Pin No. 1 to 16)

Pin No.	Pin name	Function
1	VCC	Voltage monitor pin for internal regulator
2	ERR	Output pin for thermal shutdown signal
3	IN1	OUT1 output control pin
4	GND	GND pin
5	GND	GND pin
6	IN2	OUT2 output control pin
7	IN3	OUT3 output control pin
8	IN4	OUT4 output control pin
9	OUT4	Output pin 4
10	OUT3	Output pin 3
11	OUT2	Output pin 2
12	GND	GND pin
13	GND	GND pin
14	OUT1	Output pin 1
15	COM	COM pin
16	VM	Connection pin for motor power supply

* All the grounding wires of the device must run on the solder mask on the PCB and be externally terminated at only one point. Also, a grounding method should be considered for efficient heat dissipation.

Input / Output Equivalent Circuit

Pin name	Input / output signal	Equivalent circuit
IN1 IN2 IN3 IN4	<p>Digital input (VIH/VIL)</p> <p>VIH: 2.0 V (min) to 5.5 V (max)</p> <p>VIL: 0 V (min) to 0.8 V (max)</p>	
ERR	<p>Digital output VOD(L)</p> <p>(Pull-up resistance: 10 kΩ to 100 kΩ)</p>	
VCC	<p>VCC voltage range</p> <p>4.75 V (min) to 5.0 V (typ.) to 5.25 V (max)</p>	
OUT1 OUT2 OUT3 OUT4 GND COM	<p>VM voltage operation range</p> <p>10 V (min) to 40 V (max)</p> <p>OUT pin withstanding voltage</p> <p>10 V (min) to 80 V (max)</p>	

* The equivalent circuit diagrams may be simplified or some parts of them may be omitted for explanatory purposes.

Functional Description

Relation between logic inputs and output MOSFET

Logic input				Output MOSFET			
IN1	IN2	IN3	IN4	OUT1	OUT2	OUT3	OUT4
L	L	L	L	Off	Off	Off	Off
H	L	L	L	On	Off	Off	Off
L	H	L	L	Off	On	Off	Off
L	L	H	L	Off	Off	On	Off
L	L	L	H	Off	Off	Off	On
H	H	H	H	On	On	On	On

Output pin for thermal shutdown detection signal (ERR output function)

ERR	Function
H	Normal operation
L	Thermal shutdown detection (TSD): active

Note: ERR pin is the Nch MOS output pin of open drain type. When using this function, please pull up the voltage level of the ERR pin to VCC. It is in the Hi-Z state (internal MOS = OFF) in the normal operation. It outputs low (internal MOS = ON) when the thermal shut down detection (TSD) is active.

When the thermal shutdown detection is cleared, the ERR pin outputs high level again (internal MOS = OFF). Moreover, when the ERR pin is not used, please leave this pin open.

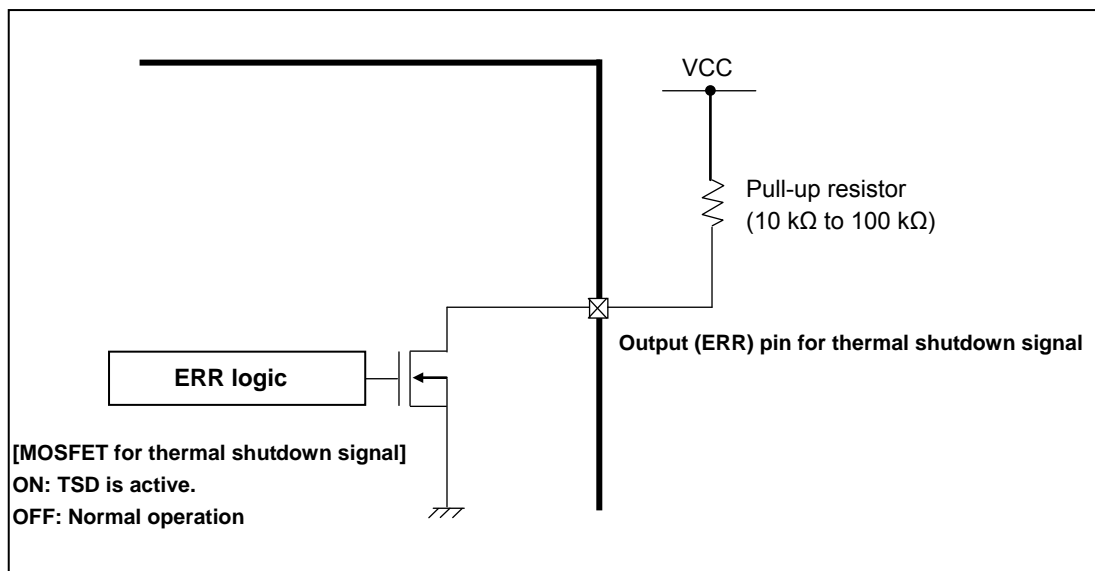

Absolute Maximum Ratings (Ta=25°C)

Characteristics	Symbol	Rating	Unit
Motor power supply VM	VM (max)	45	V
Difference voltage between VM and COM	VDIFF (max)	45	V
Motor output voltage	VOUT (max)	80	V
Motor output current (per one channel)	IOUT (max)	1.5	A
Internal logic power supply	VCC (max)	6.0	V
Logic input voltage	VIN(H) (max)	6.0	V
	VIN(L) (min)	-0.4	V
ERR output pin voltage range	VOD (max)	6.0	V
ERR output pin inflow current range	IOD (max)	20	mA
Power dissipation (standalone)	PD	1.47 (Note 1)	W
		2.7 (Note 2)	
Operating temperature	Topr	-20 to 85	°C
Storage temperature	Tstr	-55 to 150	°C
Junction temperature	Tj (max)	150	°C

Note 1: Standalone. When Ta exceeds 25°C, derating with 11.8 mW/°C is necessary.

Note 2: On PCB (size: 50 mm × 50 mm × 1.6 mm, Cu area: 50 %, single-side glass epoxy). When Ta exceeds 25°C, derating with 21.6 mW/°C is necessary.

Absolute maximum ratings

The absolute maximum ratings of a semiconductor device are a set of ratings that must not be exceeded, even for a moment. Do not exceed any of these ratings. Exceeding the rating (s) may cause device breakdown, damage or deterioration, and may result in injury by explosion or combustion, including peripheral circuits and parts. The value of even one parameter of the absolute maximum ratings should not be exceeded under any circumstances. The device does not have overvoltage detection circuit. Therefore, the device is damaged if a voltage exceeding its rated maximum is applied. All voltage ratings, including supply voltages, must always be followed. The other notes and considerations described later should also be referred to.

Operation Ranges (Ta=-20 to 85°C)

Characteristics	Symbol	Test condition	Min	Typ.	Max	Unit
Motor power supply VM	VM	—	10	—	40	V
Motor output voltage	VOUT	—	0	—	80	V
Motor output current	IOUT	Ta=25°C, per one channel	—	0.75	1.5	A
Internal logic power supply voltage	VCC	—	4.75	5.0	5.25	V
Logic input voltage	VIN(H)	Logic input high level	2.0	—	5.5	V
	VIN(L)	Logic input low level	0	—	0.8	V

Note: Please use the device with extra margin regarding the absolute maximum ratings. Moreover, please pay attention to the thermal conditions enough during use.

Electrical Characteristics 1 (Ta=25°C and VM=24 V, unless otherwise specified.)

Characteristics		Symbol	Test condition	Min	Typ.	Max	Unit
Logic input voltage		VIH	Logic input voltage High level (Note)	2.0	—	5.5	V
		VIL	Logic input voltage Low level (Note)	GND	—	0.8	V
Input hysteresis voltage		VIN(HYS)	Logic input pin (Note)	100	—	300	mV
Logic input current	High	IIN(H)	Logic input voltage High level (VIN=3.3 V)	—	33	55	μA
	Low	IIN(L)	Logic input voltage Low level (VIN=0 V)	—	—	1	μA
IM consumption current		IM	Output pins: open, in normal operation, motor output-stage operation	—	3.0	5.0	mA
Remaining voltage of ERR output		VOD(L)	IOD=10 mA	0	—	0.5	V
Regenerative diode forward voltage		VFN	IOUT=1.5 A	0.9	1.1	1.5	V
Output MOSFET OFF leakage current		Ileak	VOUT=80 V, Output MOSFET: OFF	—	—	1	μA
Output MOSFET Between drain and source On-resistance		RON (D-S)	IOUT=1.5 A	—	0.25	0.35	Ω

Note: VIH is defined as the VIN voltage that causes the outputs to change when the voltage of the test pin is gradually raised from 0 V.

VIL is defined as the VIN voltage that causes the outputs to change when the voltage of the pin is then gradually lowered. The difference between VIL and VIH is defined as the input hysteresis(VIN(HYS)).

Electrical Characteristics 2 (Ta=25°C and VM=24 V, unless otherwise specified.)

Characteristics	Symbol	Test condition	Min	Typ.	Max	Unit
VCC pin current	ICC	4.75 V ≤ VCC ≤ 5.25 V	—	2.5	5.0	mA
Temperature threshold of thermal shutdown detection (TSD) (Note 1)	TjTSD	—	155	170	185	°C
VM recovery voltage	VMR	—	7.0	8.0	9.0	V
Over current detection (ISD) threshold (Note 2)	ISD	(Design value)	2.1	3.0	5.0	A

Note 1: Thermal shutdown (TSD)

When the junction temperature of the IC reaches the TSD threshold, the TSD circuit operates and turns off the output transistors. Noise rejection blanking time is provided to avoid misdetection by switching. The IC operation recovers automatically after specified recovery time passes. The TSD circuit is a backup function to detect a thermal error, therefore it is not recommended to be used aggressively.

Note 2: Over-current detection (ISD)

When the output current reaches the threshold, the ISD circuit operates and turns off the output transistors. Noise rejection blanking time is provided to avoid misdetection by switching. The IC operation recovers automatically after specified recovery time passes.

Cautions on over current detection (ISD) and thermal shutdown detection (TSD)

The ISD and TSD circuits are only intended to provide temporary protection against irregular conditions such as an output short-circuits; they do not necessarily guarantee the complete IC safety. If the device is used beyond the specified operating ranges, these circuits may not operate properly: then the device may be damaged due to an output short-circuit. The ISD circuit is only intended to provide a temporary protection against an output short-circuit. If such condition persists for a long time, the device may be damaged due to overstress. Overcurrent conditions must be removed immediately by external hardware.

Back-EMF

While a motor is rotating, there is a timing at which power is fed back to the power supply. At that timing, the motor current recirculates back to the power supply due to the effect of the motor back-EMF. If the power supply does not have enough sink capability, the power supply and output pins of the device might rise above the rated voltages. The magnitude of the motor back-EMF varies with usage conditions and motor characteristics. It must be fully verified that there is no risk that the device or other components will be damaged or fail due to the motor back-EMF.

IC mounting

Do not insert devices incorrectly or in the wrong orientation. Otherwise, it may cause breakdown, damage and/or deterioration of the device.

AC Electrical Characteristics (Ta=25°C and VM=24 V, unless otherwise specified.)

Characteristics	Symbol	Test condition	Min	Typ.	Max	Unit
Minimum pulse width of logic input	tIN(twp)	(Design value)	1.0	—	—	μs
	tIN(twn)	(Design value)	1.0	—	—	μs
Output MOSFET switching characteristics	tr	—	0.05	0.10	0.15	μs
	tf	—	0.05	0.10	0.15	μs
Output MOSFET response characteristics	tpLH(IN)	Between IN and OUT	0.20	0.70	1.20	μs
	tpHL(IN)	Between IN and OUT	0.20	0.70	1.20	μs
OSCS frequency	fOSCS	—	5120	6400	7680	kHz
Over current detection (ISD) masking time	tISD(mask)	fOSCS(=6.4 MHz)×8 clk	1.0	1.25	1.5	μs
Off time after over current detection (ISD)	—	—	260	320	390	μs
Thermal shutdown detection (TSD) masking time	tTSD(mask)	fOSCS(=6.4 MHz)×32 clk	4.0	5.0	6.0	μs
Off time after thermal shutdown detection (TSD)	—	—	260	320	390	μs

AC Characteristics Timing chart

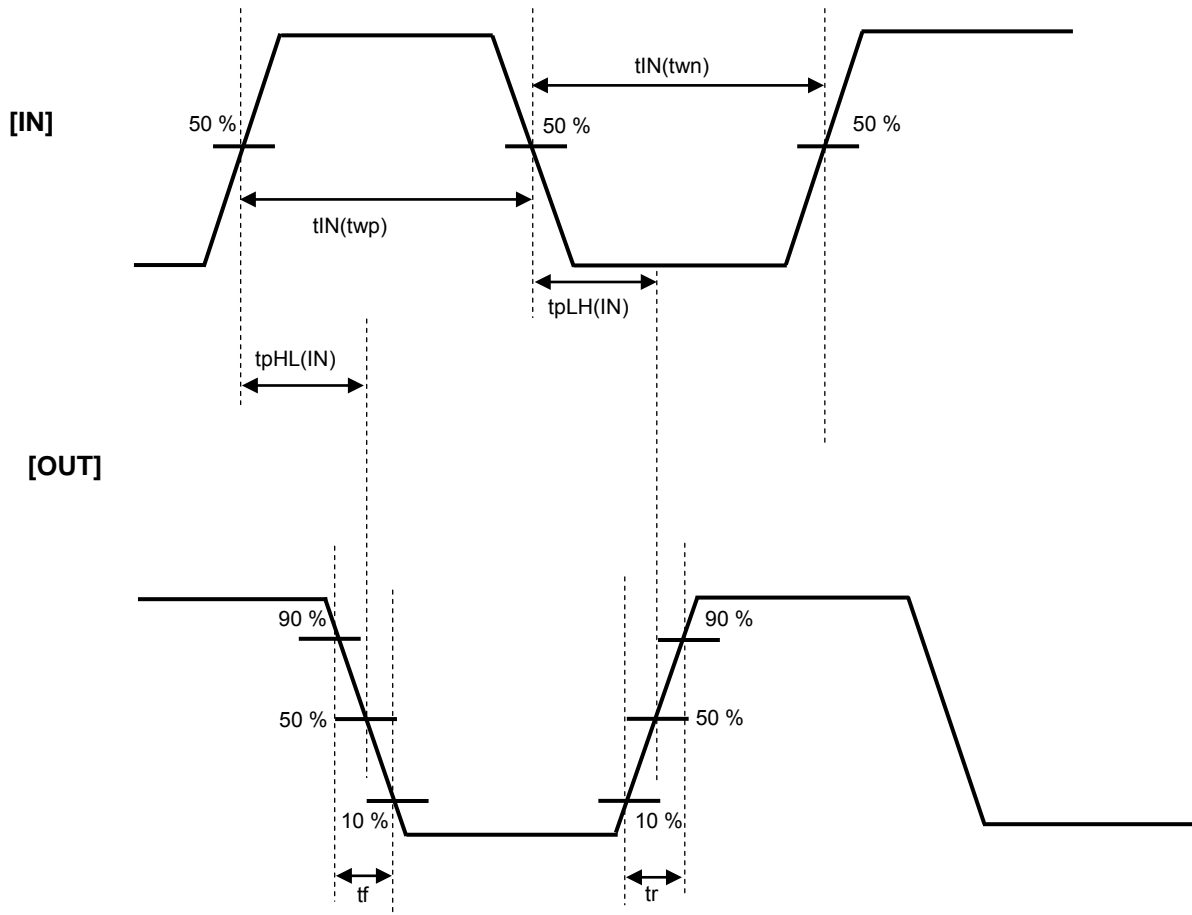

Timing charts may be simplified for explanatory purposes.

Application Circuit Example

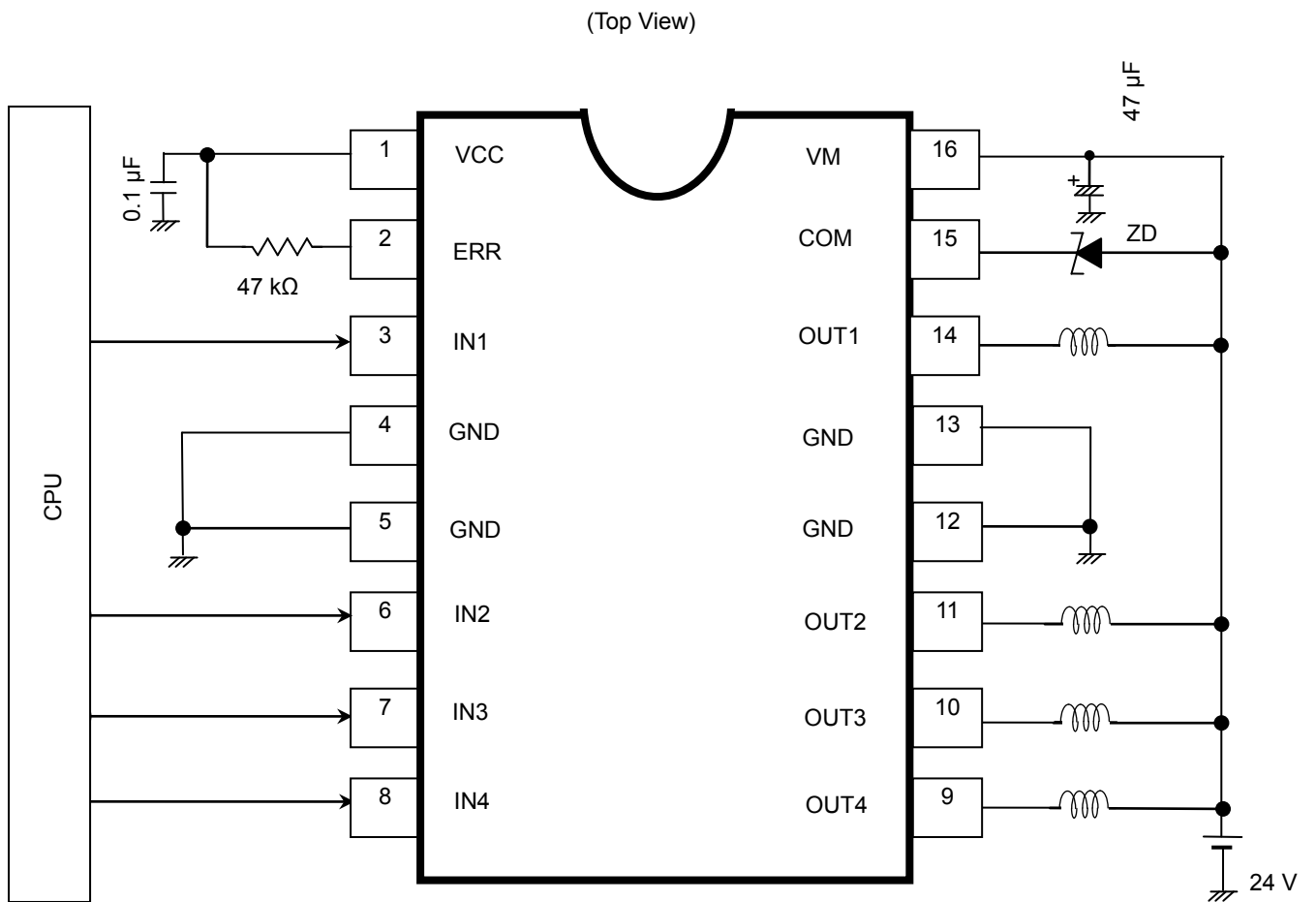

The application circuits shown in this document are provided for reference purposes only, and are not guaranteed for mass production.

As for zener diodes, recommended zener voltage is higher than VM.

Package Dimensions

DIP16-P-300-2.54A

Unit: mm

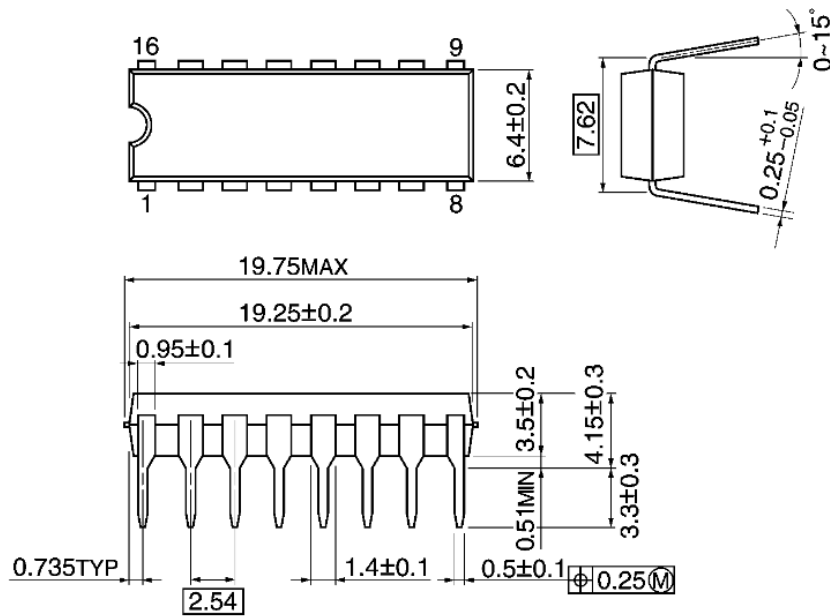

Weight: 1.11 g (typ.)

Notes on Contents

1. Block Diagrams

Some of the functional blocks, circuits, or constants in the block diagram may be omitted or simplified for explanatory purposes.

2. Equivalent Circuits

The equivalent circuit diagrams may be simplified or some parts of them may be omitted for explanatory purposes.

3. Timing Charts

Timing charts may be simplified for explanatory purposes.

4. Application Circuits

The application circuits shown in this document are provided for reference purposes only. Thorough evaluation is required, especially at the mass-production design stage.

Providing these application circuit examples does not grant a license for industrial property rights.

IC Usage Considerations

Notes on handling of ICs

- (1) The absolute maximum ratings of a semiconductor device are a set of ratings that must not be exceeded, even for a moment. Do not exceed any of these ratings. Exceeding the rating(s) may cause device breakdown, damage or deterioration, and may result in injury by explosion or combustion.
- (2) Use an appropriate power supply fuse to ensure that a large current does not continuously flow in the case of overcurrent and/or IC failure. The IC will fully break down when used under conditions that exceed its absolute maximum ratings, when the wiring is routed improperly or when an abnormal pulse noise occurs from the wiring or load, causing a large current to continuously flow and the breakdown can lead to smoke or ignition. To minimize the effects of the flow of a large current in the case of breakdown, appropriate settings, such as fuse capacity, fusing time and insertion circuit location, are required.
- (3) If your design includes an inductive load such as a motor coil, incorporate a protection circuit into the design to prevent device malfunction or breakdown caused by the current resulting from the inrush current at power ON or the negative current resulting from the back electromotive force at power OFF. IC breakdown may cause injury, smoke or ignition. Use a stable power supply with ICs with built-in protection functions. If the power supply is unstable, the protection function may not operate, causing IC breakdown. IC breakdown may cause injury, smoke or ignition.
- (4) Do not insert devices in the wrong orientation or incorrectly. Make sure that the positive and negative terminals of power supplies are connected properly. Otherwise, the current or power consumption may exceed the absolute maximum rating, and exceeding the rating(s) may cause device breakdown, damage or deterioration, and may result in injury by explosion or combustion. In addition, do not use any device inserted in the wrong orientation or incorrectly to which current is applied even just once.
- (5) Carefully select external components (such as inputs and negative feedback capacitors) and load components (such as speakers), for example, power amp and regulator. If there is a large amount of leakage current such as from input or negative feedback condenser, the IC output DC voltage will increase. If this output voltage is connected to a speaker with low input withstand voltage, overcurrent or IC failure may cause smoke or ignition. (The overcurrent may cause smoke or ignition from the IC itself.) In particular, please pay attention when using a Bridge Tied Load (BTL) connection-type IC that inputs output DC voltage to a speaker directly.

Points to remember on handling of ICs

Overcurrent detection Circuit

Overcurrent detection circuits (referred to as current limiter circuits) do not necessarily protect ICs under all circumstances. If the overcurrent detection circuits operate against the overcurrent, clear the overcurrent status immediately.

Depending on the method of use and usage conditions, exceeding absolute maximum ratings may cause the overcurrent detection circuit to operate improperly or IC breakdown may occur before operation. In addition, depending on the method of use and usage conditions, if overcurrent continues to flow for a long time after operation, the IC may generate heat resulting in breakdown.

Thermal Shutdown Circuit

Thermal shutdown circuits do not necessarily protect ICs under all circumstances. If the thermal shutdown circuits operate against the over-temperature, clear the heat generation status immediately.

Depending on the method of use and usage conditions, exceeding absolute maximum ratings may cause the thermal shutdown circuit to operate improperly or IC breakdown to occur before operation.

Heat Radiation Design

When using an IC with large current flow such as power amp, regulator or driver, design the device so that heat is appropriately radiated, in order not to exceed the specified junction temperature (T_j) at any time or under any condition. These ICs generate heat even during normal use. An inadequate IC heat radiation design can lead to decrease in IC life, deterioration of IC characteristics or IC breakdown. In addition, when designing the device, take into consideration the effect of IC heat radiation with peripheral components.

Back-EMF

When a motor rotates in the reverse direction, stops or slows abruptly, current flows back to the motor's power supply owing to the effect of back-EMF. If the current sink capability of the power supply is small, the device's motor power supply and output pins might be exposed to conditions beyond the absolute maximum ratings. To avoid this problem, take the effect of back-EMF into consideration in system design.

RESTRICTIONS ON PRODUCT USE

Toshiba Corporation and its subsidiaries and affiliates are collectively referred to as "TOSHIBA".

Hardware, software and systems described in this document are collectively referred to as "Product".

- TOSHIBA reserves the right to make changes to the information in this document and related Product without notice.
- This document and any information herein may not be reproduced without prior written permission from TOSHIBA. Even with TOSHIBA's written permission, reproduction is permissible only if reproduction is without alteration/omission.
- Though TOSHIBA works continually to improve Product's quality and reliability, Product can malfunction or fail. Customers are responsible for complying with safety standards and for providing adequate designs and safeguards for their hardware, software and systems which minimize risk and avoid situations in which a malfunction or failure of Product could cause loss of human life, bodily injury or damage to property, including data loss or corruption. Before customers use the Product, create designs including the Product, or incorporate the Product into their own applications, customers must also refer to and comply with (a) the latest versions of all relevant TOSHIBA information, including without limitation, this document, the specifications, the data sheets and application notes for Product and the precautions and conditions set forth in the "TOSHIBA Semiconductor Reliability Handbook" and (b) the instructions for the application with which the Product will be used with or for. Customers are solely responsible for all aspects of their own product design or applications, including but not limited to (a) determining the appropriateness of the use of this Product in such design or applications; (b) evaluating and determining the applicability of any information contained in this document, or in charts, diagrams, programs, algorithms, sample application circuits, or any other referenced documents; and (c) validating all operating parameters for such designs and applications. **TOSHIBA ASSUMES NO LIABILITY FOR CUSTOMERS' PRODUCT DESIGN OR APPLICATIONS.**
- **PRODUCT IS NEITHER INTENDED NOR WARRANTED FOR USE IN EQUIPMENTS OR SYSTEMS THAT REQUIRE EXTRAORDINARILY HIGH LEVELS OF QUALITY AND/OR RELIABILITY, AND/OR A MALFUNCTION OR FAILURE OF WHICH MAY CAUSE LOSS OF HUMAN LIFE, BODILY INJURY, SERIOUS PROPERTY DAMAGE AND/OR SERIOUS PUBLIC IMPACT ("UNINTENDED USE").** Except for specific applications as expressly stated in this document, Unintended Use includes, without limitation, equipment used in nuclear facilities, equipment used in the aerospace industry, medical equipment, equipment used for automobiles, trains, ships and other transportation, traffic signaling equipment, equipment used to control combustions or explosions, safety devices, elevators and escalators, devices related to electric power, and equipment used in finance-related fields. **IF YOU USE PRODUCT FOR UNINTENDED USE, TOSHIBA ASSUMES NO LIABILITY FOR PRODUCT.** For details, please contact your TOSHIBA sales representative.
- Do not disassemble, analyze, reverse-engineer, alter, modify, translate or copy Product, whether in whole or in part.
- Product shall not be used for or incorporated into any products or systems whose manufacture, use, or sale is prohibited under any applicable laws or regulations.
- The information contained herein is presented only as guidance for Product use. No responsibility is assumed by TOSHIBA for any infringement of patents or any other intellectual property rights of third parties that may result from the use of Product. No license to any intellectual property right is granted by this document, whether express or implied, by estoppel or otherwise.
- **ABSENT A WRITTEN SIGNED AGREEMENT, EXCEPT AS PROVIDED IN THE RELEVANT TERMS AND CONDITIONS OF SALE FOR PRODUCT, AND TO THE MAXIMUM EXTENT ALLOWABLE BY LAW, TOSHIBA (1) ASSUMES NO LIABILITY WHATSOEVER, INCLUDING WITHOUT LIMITATION, INDIRECT, CONSEQUENTIAL, SPECIAL, OR INCIDENTAL DAMAGES OR LOSS, INCLUDING WITHOUT LIMITATION, LOSS OF PROFITS, LOSS OF OPPORTUNITIES, BUSINESS INTERRUPTION AND LOSS OF DATA, AND (2) DISCLAIMS ANY AND ALL EXPRESS OR IMPLIED WARRANTIES AND CONDITIONS RELATED TO SALE, USE OF PRODUCT, OR INFORMATION, INCLUDING WARRANTIES OR CONDITIONS OF MERCHANTABILITY, FITNESS FOR A PARTICULAR PURPOSE, ACCURACY OF INFORMATION, OR NONINFRINGEMENT.**
- Do not use or otherwise make available Product or related software or technology for any military purposes, including without limitation, for the design, development, use, stockpiling or manufacturing of nuclear, chemical, or biological weapons or missile technology products (mass destruction weapons). Product and related software and technology may be controlled under the applicable export laws and regulations including, without limitation, the Japanese Foreign Exchange and Foreign Trade Law and the U.S. Export Administration Regulations. Export and re-export of Product or related software or technology are strictly prohibited except in compliance with all applicable export laws and regulations.
- Please contact your TOSHIBA sales representative for details as to environmental matters such as the RoHS compatibility of Product. Please use Product in compliance with all applicable laws and regulations that regulate the inclusion or use of controlled substances, including without limitation, the EU RoHS Directive. **TOSHIBA ASSUMES NO LIABILITY FOR DAMAGES OR LOSSES OCCURRING AS A RESULT OF NONCOMPLIANCE WITH APPLICABLE LAWS AND REGULATIONS.**

Mouser Electronics

Authorized Distributor

Click to View Pricing, Inventory, Delivery & Lifecycle Information:

[Toshiba:](#)

[TB67S111PG,HJ](#)