

Nov.1.2023 Copyright 2023 HIROSE ELECTRIC CO., LTD. All Rights Reserved.  
 In case of consideration for using Automotive equipment / device which demand high reliability, kindly contact our sales window correspondents.

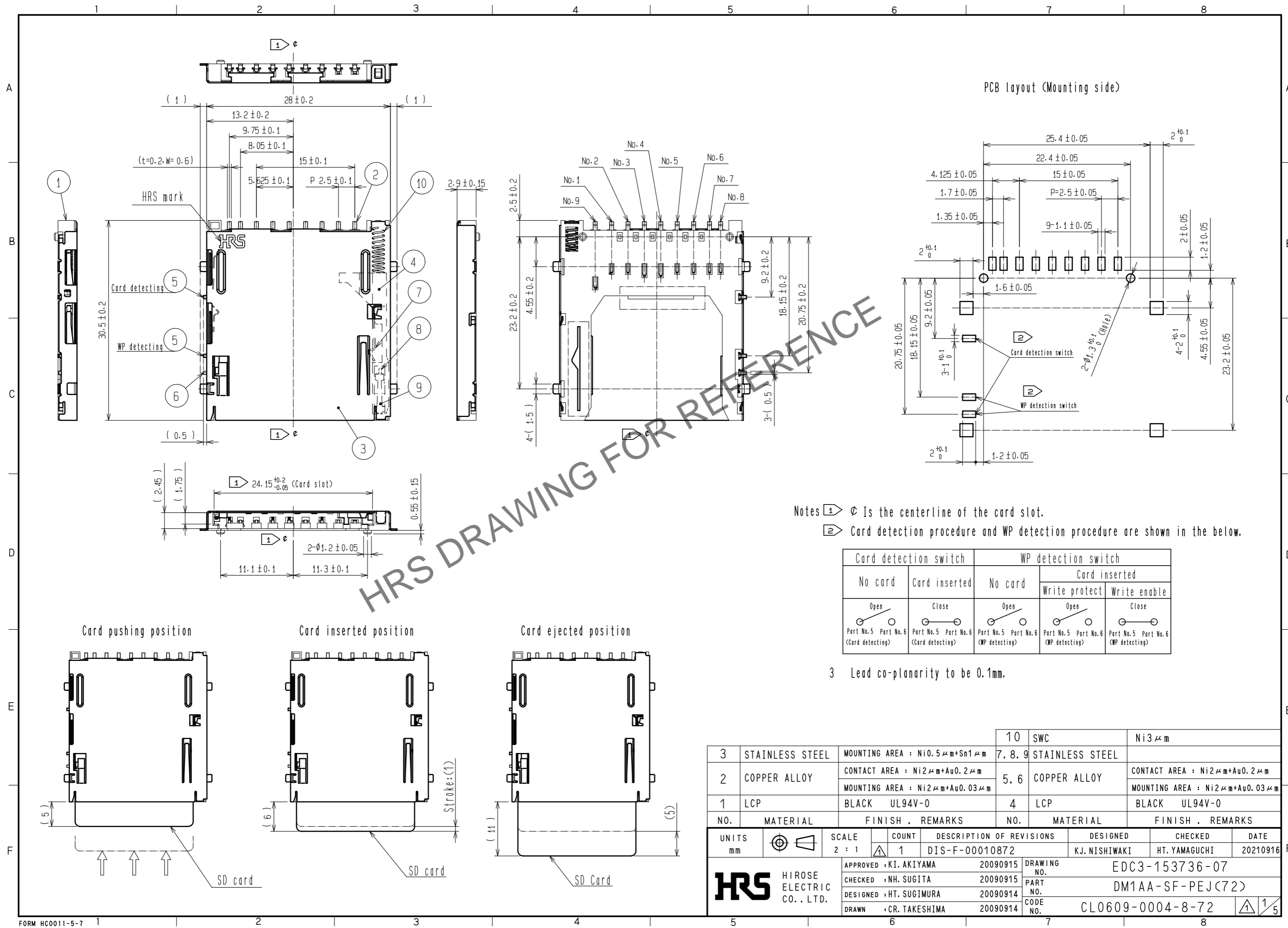

HRS DRAWING FOR REFERENCE

Notes ①  $\phi$  Is the centerline of the card slot.  
 ② Card detection procedure and WP detection procedure are shown in the below.

Card detection switch		WP detection switch		
No card	Card inserted	No card	Card inserted	
			Write protect	Write enable
Open	Close	Open	Open	Close
Part No.5 (Card detecting)	Part No.6 (Card detecting)	Part No.5 (WP detecting)	Part No.5 (WP detecting)	Part No.6 (WP detecting)

3 Lead co-planarity to be 0.1mm.

3	STAINLESS STEEL	MOUNTING AREA : Ni0.5 $\mu$ m+Sn1 $\mu$ m	10	SWC	Ni3 $\mu$ m		
2	COPPER ALLOY	CONTACT AREA : Ni2 $\mu$ m+Au0.2 $\mu$ m MOUNTING AREA : Ni2 $\mu$ m+Au0.03 $\mu$ m	7, 8, 9	STAINLESS STEEL	CONTACT AREA : Ni2 $\mu$ m+Au0.2 $\mu$ m MOUNTING AREA : Ni2 $\mu$ m+Au0.03 $\mu$ m		
1	LCP	BLACK UL94V-0	5, 6	COPPER ALLOY			
NO.	MATERIAL	FINISH . REMARKS	NO.	MATERIAL	FINISH . REMARKS		
UNITS mm	$\phi$ $\nabla$	SCALE 2 : 1	COUNT 1	DESCRIPTION OF REVISIONS DIS-F-00010872	DESIGNED KJ. NISHIWAKI	CHECKED HT. YAMAGUCHI	DATE 20210916
<b>HRS</b> HIROSE ELECTRIC CO., LTD.		APPROVED : KI. AKIYAMA 20090915	DRAWING NO. EDC3-153736-07				
		CHECKED : NH. SUGITA 20090915	PART NO. DM1AA-SF-PEJ(72)				
		DESIGNED : HT. SUGIMURA 20090914	CODE NO. CL0609-0004-8-72				
		DRAWN : CR. TAKESHIMA 20090914					

Nov.1.2023 Copyright 2023 HIROSE ELECTRIC CO., LTD. All Rights Reserved.  
In case of consideration for using Automotive equipment / device which demand high reliability, kindly contact our sales window correspondents.

# Configuration of packing tray

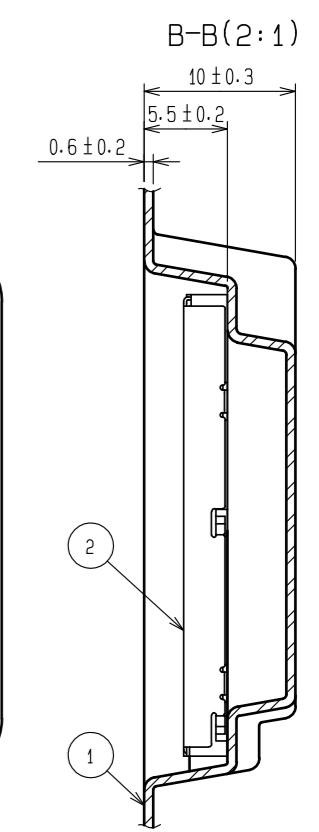
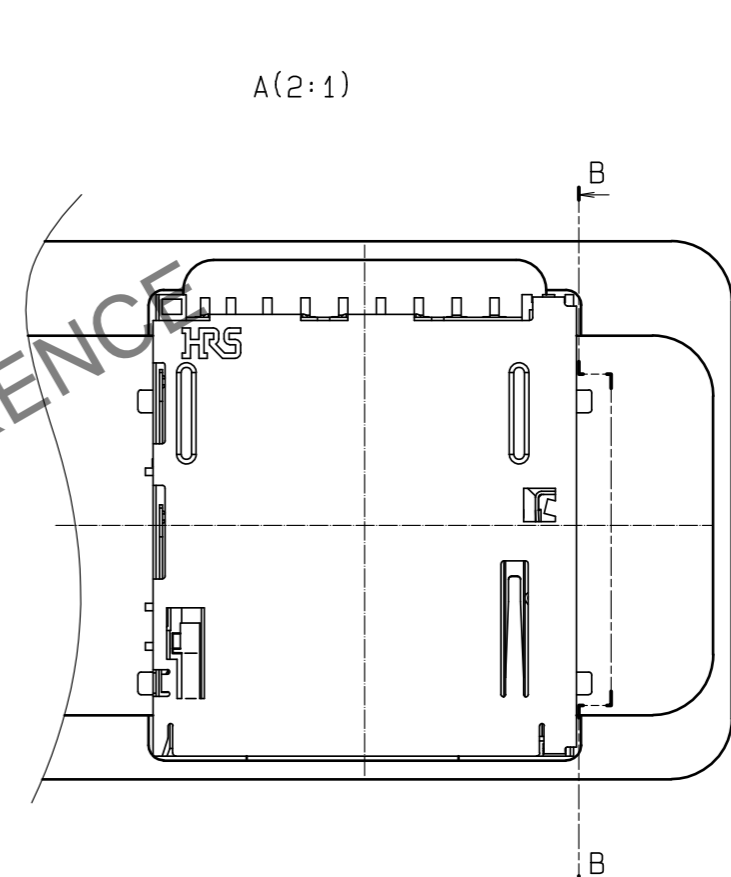
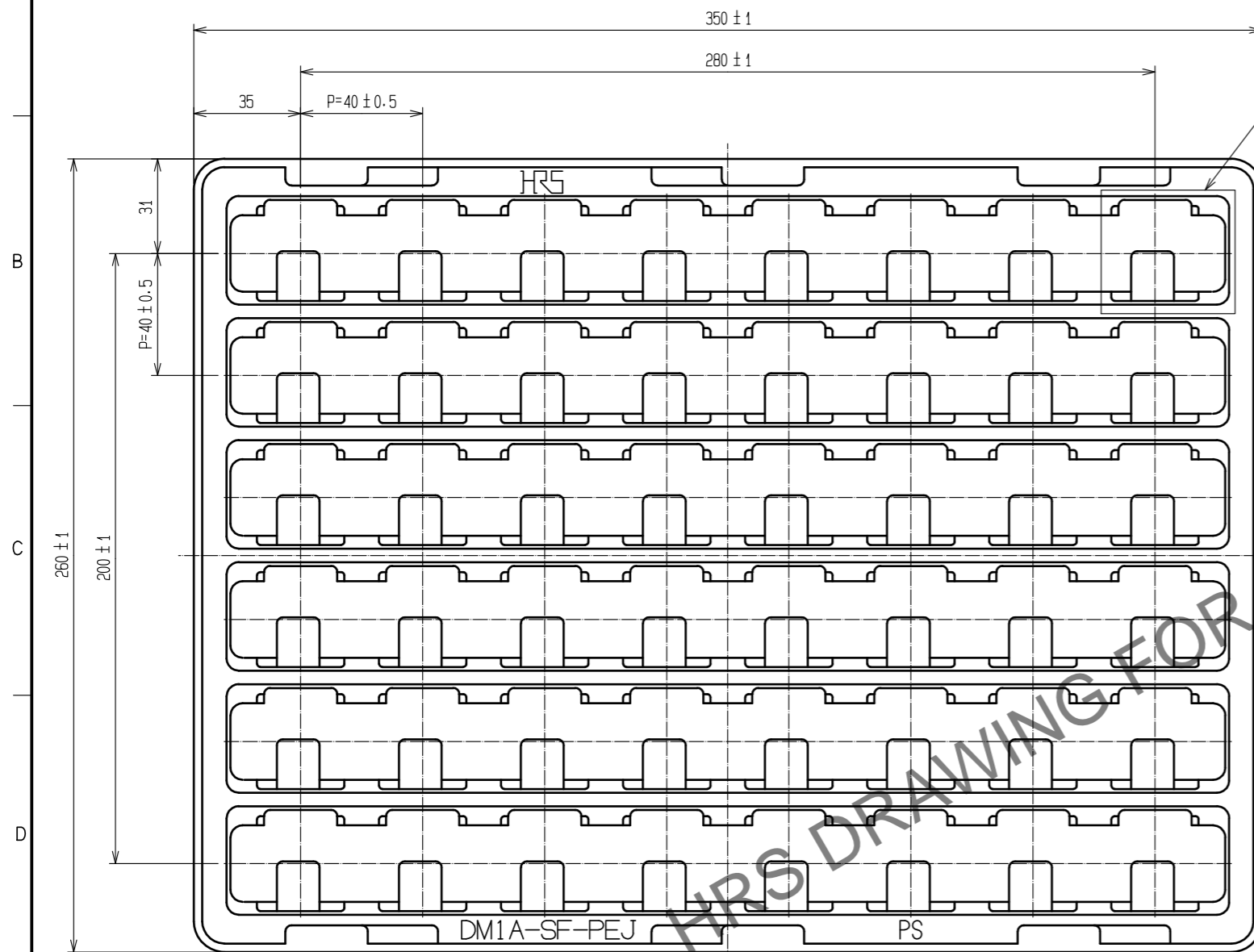

Note 1. Quantity : 48pcs./tray

2	CONNECTOR:DM1AA-SF-PEJ(72)
1	PS CLEAR
NO.	MATERIAL

<b>HRS</b>	DRAWING NO.	EDC3-153736-07
	PART NO.	DM1AA-SF-PEJ(72)
	CODE NO.	CL0609-0004-8-72
		2/5

# Product information and handling instructions

## (1) Recommended enclosure dimensions

Please be careful not to interfere with the SD card and the connector when installing the enclosure near the connector.  
Please note that when the SD card is fitted, the contact will protrude up to 0.6 mm from the outer shape of the connector.

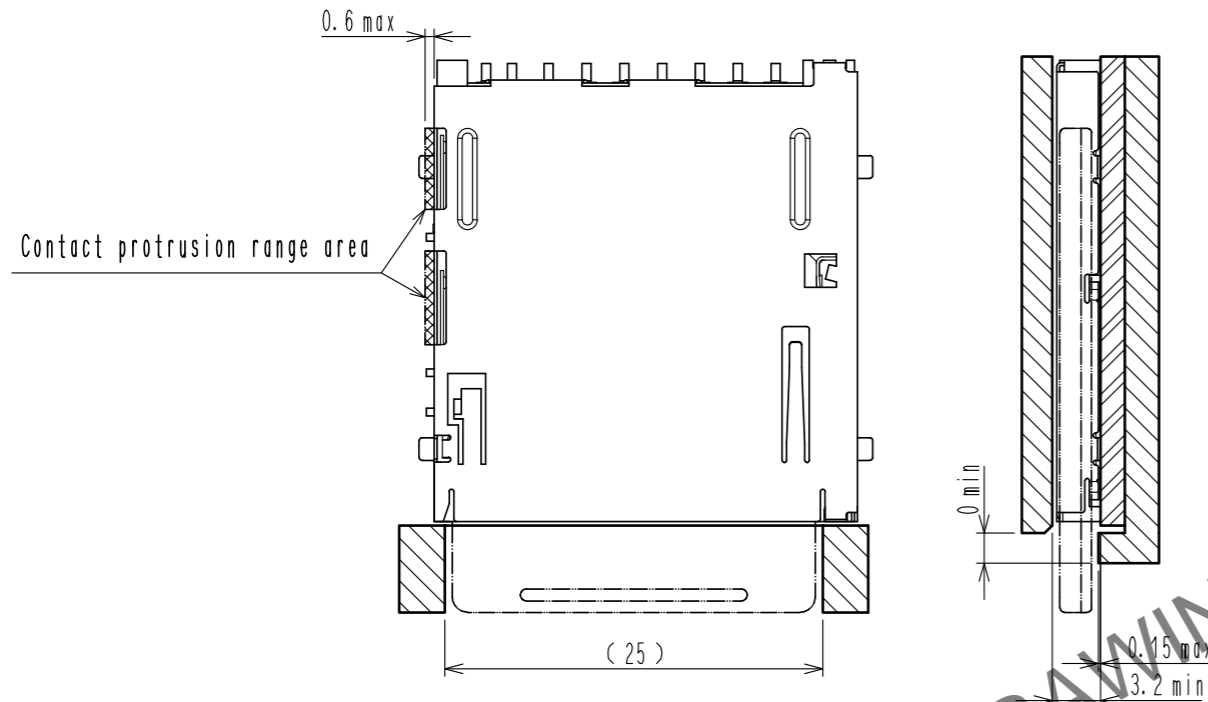

## (2) Recommended dimensions for attaching a cover (lid)

Please install a cover (lid) to prevent the card from falling or becoming misplaced due to unforeseen causes.  
The following dimensions are recommended for attaching a cover (lid).

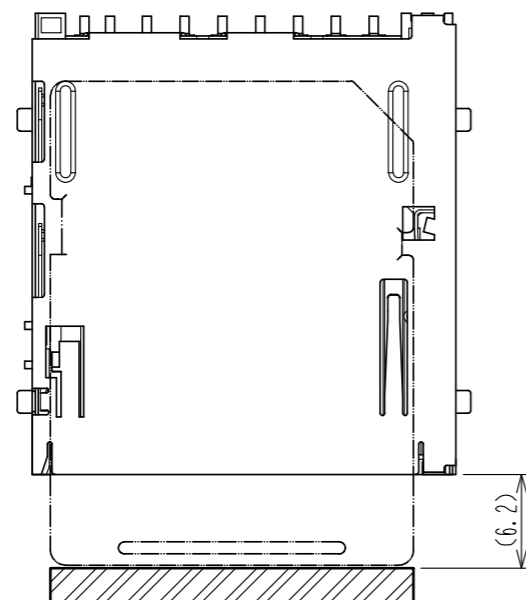

(3) If you will be performing card recognition and operating inspections in your assembly process, please pay attention to the points listed below.

- Please use an SD card whose main external dimensions in the figure below are within the dimensional tolerance.
- Make sure that there is no severe wear on the contact pad (base material must not be exposed).
- Do not use anything with scratches or uneven shapes on the outer surface of the SD card.
- Please be careful not to put labels etc. on the surface of the SD card.

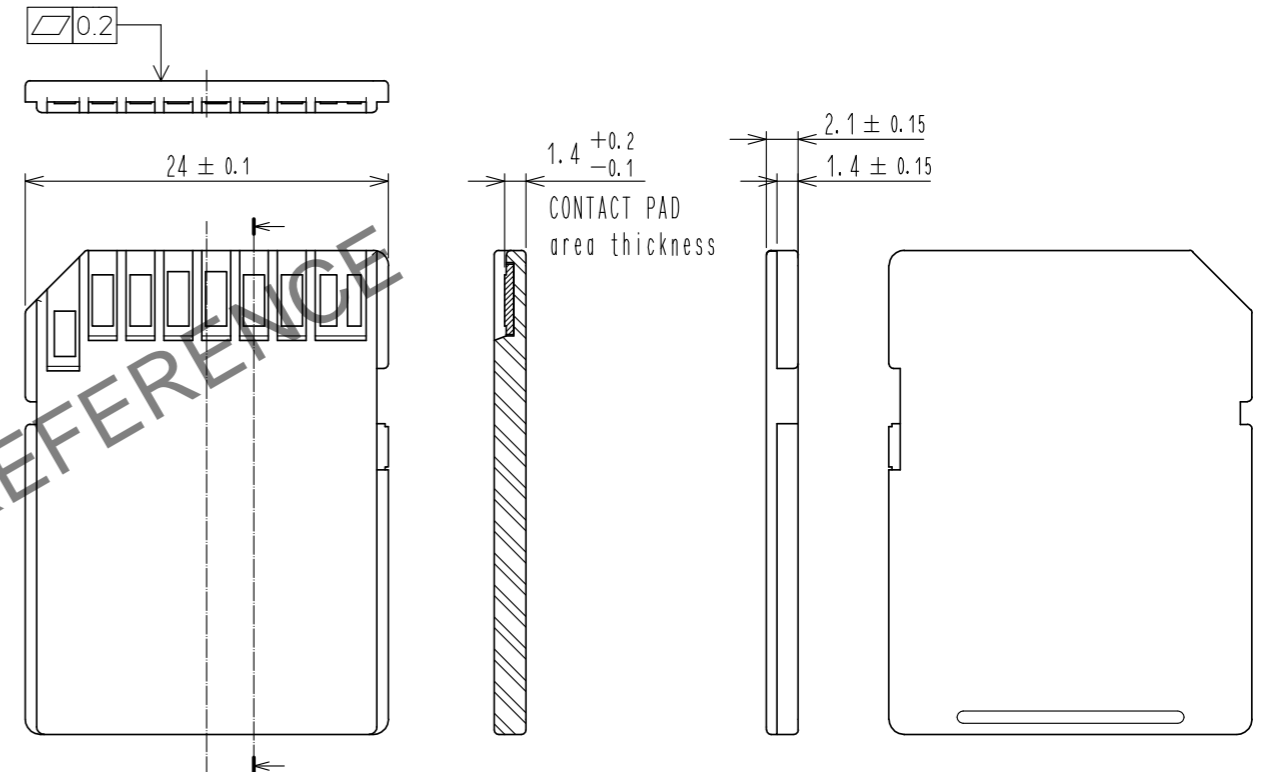

(4) The connector's detection switch is exposed due to its low profile design.  
Please handle with care, foreign matter may enter etc.

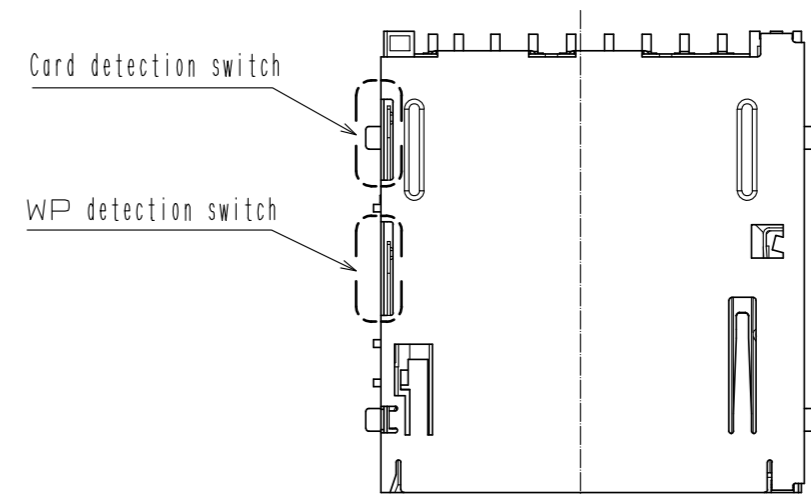

**HRS**

DRAWING NO.	EDC3-153736-07
PART NO.	DM1AA-SF-PEJ(72)
CODE NO.	CL0609-0004-8-72

Nov.1.2023 Copyright 2023 HIROSE ELECTRIC CO., LTD. All Rights Reserved.  
In case of consideration for using Automotive equipment / device which demand high reliability, kindly contact our sales window correspondents.

(5) Excessive force may cause the connector to fail or become damaged.  
Please handle the connector with care and make sure that it does not deform in any way.  
In particular, avoid the following if you will be performing card recognition and operating inspections in your assembly process without installing the product to an enclosure.

- Do not insert or withdraw cards at an angle, whether in a vertical or lateral direction.
- Do not insert or withdraw a partially inserted card by prying it in a vertical or lateral direction.

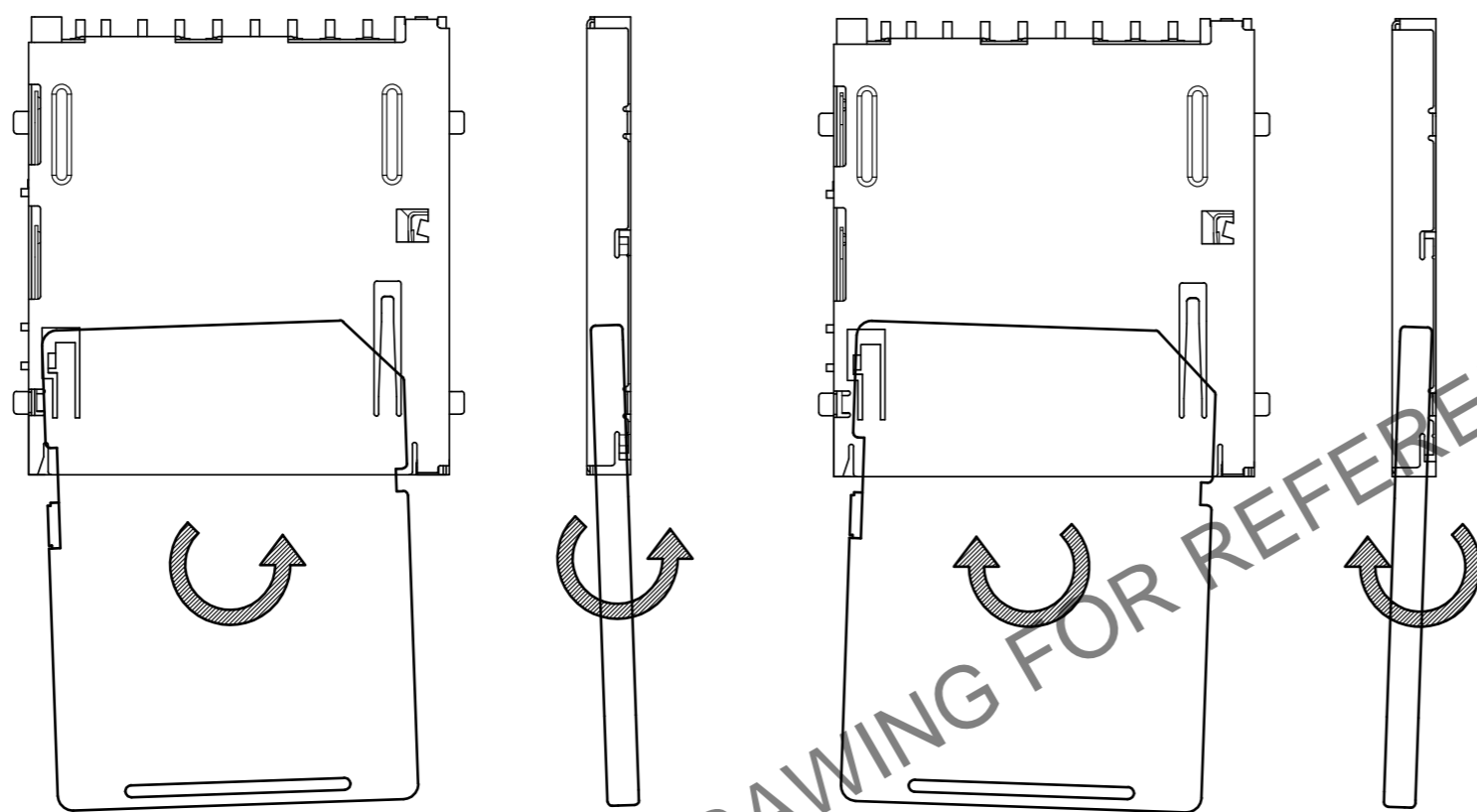

(6) Recommended conditions of reflow

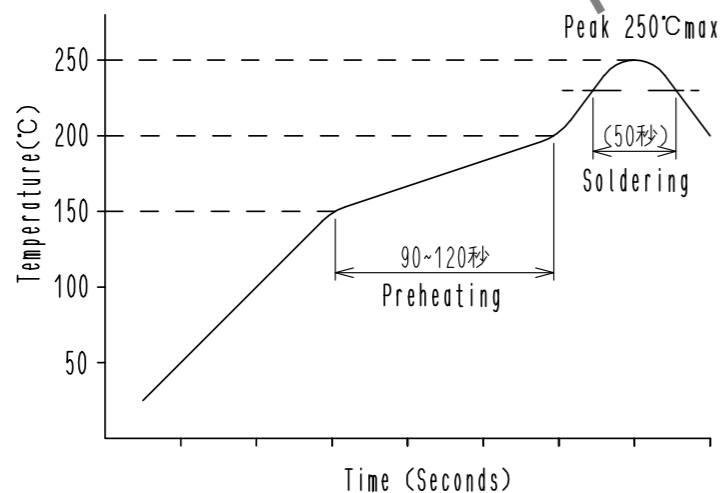

<Conditions>

- Reflow method : Combined far-IR and hot-air reflow
- Reflow atmosphere : Ambient air, N<sub>2</sub>
- Solder : Cream type Sn/3.0Ag/0.5Cu  
(M705-GRN360-K2-V made by Senju Kinzoku)
- Board tested : 60×100×1mm glass epoxy
- Metal mask thickness : 0.15mm
- Number of reflow cycles : ※Two cycles max

This temperature profile applies to the conditions stated above.  
Since temperature profiles can vary depending on the type and manufacturer of the cream solder used, as well as board size and other factors including conditions of the parts to be mounted, make sure to check the mounting conditions carefully before use.  
※Please use surface mounting adhesive when reflow back side.

<Impossible area to surface mounting adhesive>

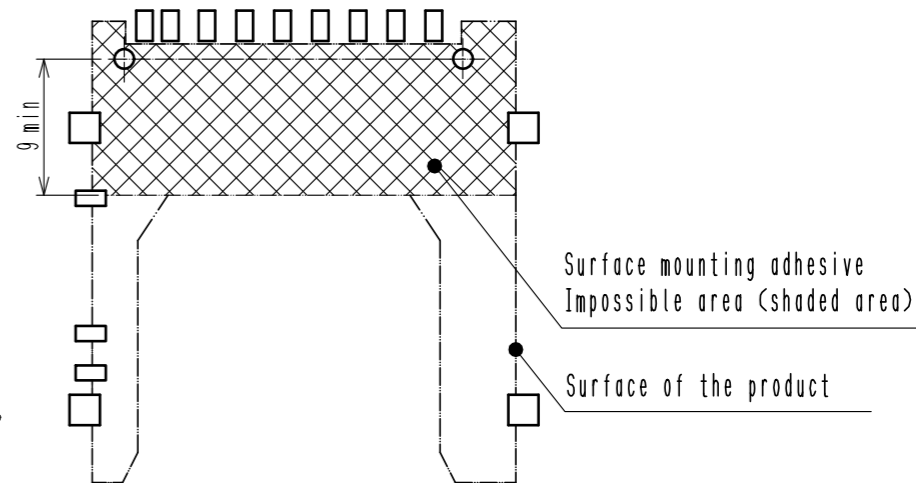

<b>HRS</b>	DRAWING NO.	EDC3-153736-07
	PART NO.	DM1AA-SF-PEJ(72)
	CODE NO.	CL0609-0004-8-72
		4/5

In case of consideration for using Automotive equipment / device which demand high reliability, kindly contact our sales window correspondents.

- (7) Please do not use a prying motion to withdraw an engaged SD card.  
This can cause damage to the SD card and/or connector.
- (8) Please clean the SD card if there is insert or withdraw feel is bad or contact defect for a specific SD card.
- (9) Markings for preventing incorrect card insertion  
If you will be displaying markings or instructions to prevent end users from inserting the card incorrectly,  
please pay extra attention to the text description and the direction of the marking used to indicate the correct direction.
- (10) This product is equipped with an ejection function. Never wash the entire connector as this could lead to problems with this function.  
If it must be washed, wash only the soldered areas and make sure that you do not leave any cleaner residues on the connector.  
Cleaner residues can cause problems with card insertion/extraction and electrical performance.
- (11) This is a connector designed to be mounted on boards.  
Make sure not to use the connector on its own as this could lead to functional problems.
- (12) Do not insert other types of SD cards.
- (13) You may find some processing liquid residue on the surface of the product but this has no effect on its quality.
- (14) Due to the material used, the surface of a SD card will be subject to sliding scratches but this will not affect product quality or performance.
- (15) It is tin-plating to part of the metal cover.  
There is a change in gloss and appearance before and after reflow for the appearance of the tin-plated part,  
but this will not affect product quality or performance.

HRS DRAWING FOR REFERENCE

<b>HRS</b>	DRAWING NO.	EDC3-153736-07	
	PART NO.	DM1AA-SF-PEJ(72)	
	CODE NO.	CL0609-0004-8-72	△ 5/5