

ON Semiconductor

Is Now

The logo for onsemi, featuring the word "onsemi" in a dark teal, lowercase, sans-serif font. The letter "i" is stylized with a white dot and a teal vertical bar. A small orange triangle is positioned above the top right of the "i". A trademark symbol (TM) is located to the right of the logo.

To learn more about onsemi™, please visit our website at
www.onsemi.com

onsemi and **onsemi** and other names, marks, and brands are registered and/or common law trademarks of Semiconductor Components Industries, LLC dba "**onsemi**" or its affiliates and/or subsidiaries in the United States and/or other countries. **onsemi** owns the rights to a number of patents, trademarks, copyrights, trade secrets, and other intellectual property. A listing of **onsemi** product/patent coverage may be accessed at www.onsemi.com/site/pdf/Patent-Marking.pdf. **onsemi** reserves the right to make changes at any time to any products or information herein, without notice. The information herein is provided "as-is" and **onsemi** makes no warranty, representation or guarantee regarding the accuracy of the information, product features, availability, functionality, or suitability of its products for any particular purpose, nor does **onsemi** assume any liability arising out of the application or use of any product or circuit, and specifically disclaims any and all liability, including without limitation special, consequential or incidental damages. Buyer is responsible for its products and applications using **onsemi** products, including compliance with all laws, regulations and safety requirements or standards, regardless of any support or applications information provided by **onsemi**. "Typical" parameters which may be provided in **onsemi** data sheets and/or specifications can and do vary in different applications and actual performance may vary over time. All operating parameters, including "Typicals" must be validated for each customer application by customer's technical experts. **onsemi** does not convey any license under any of its intellectual property rights nor the rights of others. **onsemi** products are not designed, intended, or authorized for use as a critical component in life support systems or any FDA Class 3 medical devices or medical devices with a same or similar classification in a foreign jurisdiction or any devices intended for implantation in the human body. Should Buyer purchase or use **onsemi** products for any such unintended or unauthorized application, Buyer shall indemnify and hold **onsemi** and its officers, employees, subsidiaries, affiliates, and distributors harmless against all claims, costs, damages, and expenses, and reasonable attorney fees arising out of, directly or indirectly, any claim of personal injury or death associated with such unintended or unauthorized use, even if such claim alleges that **onsemi** was negligent regarding the design or manufacture of the part. **onsemi** is an Equal Opportunity/Affirmative Action Employer. This literature is subject to all applicable copyright laws and is not for resale in any manner. Other names and brands may be claimed as the property of others.



ON Semiconductor®

FAN1100-F085 Ignition Gate Driver IC

FAN1100-F085- Ignition Gate Driver IC

Features

- Signal Line Input Buffer
- Input spike filter
- Operation from Ignition or Battery line
- Ground shift tolerance +/- 1.5 V
- Programmable maximum dwell time
- Programmable Input Pull down current
- Control IGBT current limiting through Vsense pin
- Soft Shutdown following Max Dwell Time out

Applications

- The FAN1100-F085 is an advanced Ignition IGBT control IC available in a SO8 package or die sales. This full featured Smart Ignition IGBT Driver is particularly advantageous in “switch on coil” applications where size and system performance of the ignition driver are important.

Description

The FAN1100-F085 is designed to directly drive an ignition IGBT and control the current and spark event of the coil. The coil current is controlled via the input pin. When the input is driven high, the output of the FAN1100-F085 is enabled to turn on the IGBT and start charging the coil. The FAN1100-F085 will sink a current (IIN) into the input pin based on programmed current on the RA line.

An input spike filter suppresses input signals of less than 13 μsec in duration. A Max Dwell timer is included in the FAN1100-F085 which will turn off the IGBT if the input stays active for longer than the programmed time. This time interval can be modified through an external capacitor on the CSSD pin. When the Max Dwell timer is exceeded, the FAN1100-F085 will enter a Soft-Shut-Down mode (SSD) slowly dropping the collector current by lowering the gate drive to the IGBT thereby discharging the coil such as to inhibit a spark event. Once the soft shutdown operation has started, any transitions on the input signal are ignored until after completion of the soft shutdown function. The FAN1100-F085 will also limit the collector current of the IGBT to I_{c(lim)} during charging. This again is done through the sense resistor in the emitter leg of the Ignition IGBT developing a signal input to the Vsense pin of the FAN1100-F085.

Ordering Information

Part Number	Operating Temperature Range	Package	Packing Method
FAN1100-F085	-40C to 150C	8-SOIC	Tape & Reel

Recommended External Components

Table 1. Recommended External Components

Component	Description	Vendor	Parameter	Typ.	Unit
R_{BAT}	Limits transient currents during load dump		R	200 to 300	Ω
C_{BAT1}	Battery or Ignition voltage filtering		C	0.47	μF
C_{BAT}	Battery noise transients		C	10	nF
C_{IN}	Noise immunity		C	10	nF
R_{SENSE}	Sense the collector current		R	20	$m\Omega$

Typical Application

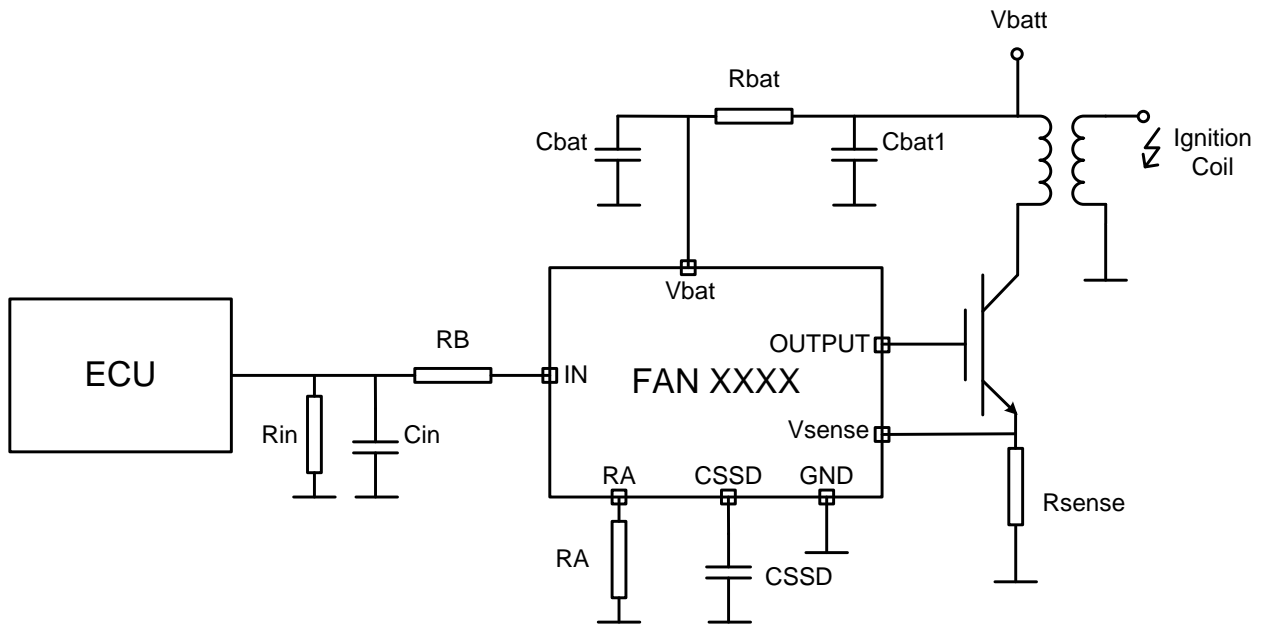
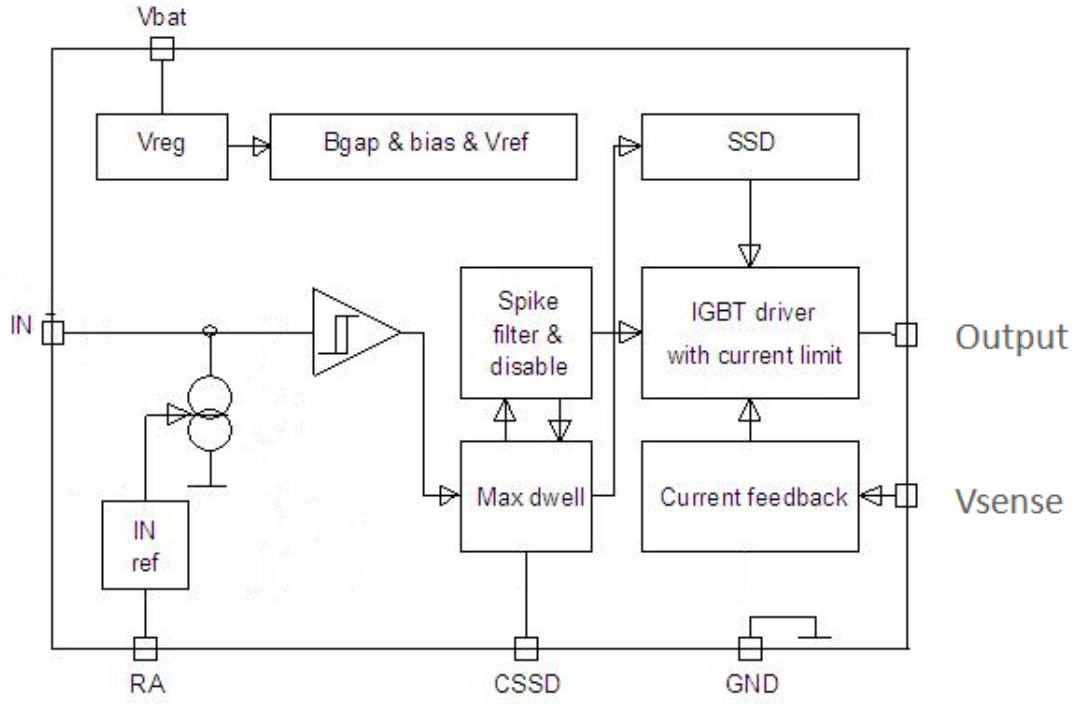

Figure 1. Typical Application

Block Diagram



Package Outline

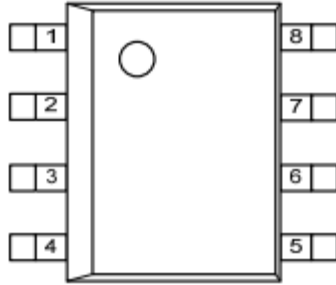

Figure 2. Pin Assignment (Top View)

Pin Descriptions

Name	Type	Description
Pin1	GND	Ground Reference of the Control IC
Pin2	Input	Signal input
Pin3	NC	
Pin4	CSSD	Maximum dwell time and Soft-Shut-Down current output (to external capacitor)
Pin5	RA	Input reference current output (to external resistor)
Pin6	Output	Gate Drive to the IGBT
Pin7	Vsense	Sense Input used for Ilim function
Pin 8	Vbat	Supply voltage

Absolute Maximum Ratings

Stresses exceeding the absolute maximum ratings may damage the device. The device may not function or be operable above the recommended operating conditions and stressing the parts to these levels is not recommended. In addition, extended exposure to stresses above the recommended operating conditions may affect device reliability. The absolute maximum ratings are stress ratings only.

Symbol	Parameter	Min.	Max.	Unit
V _{bat}	Voltage at V _{bat} pin (excl. EMC transients)	-0.3	28	V
V _{IN}	Voltage at Input pin with external R _{in}	- 2	16	V
V _{RA} , V _{CSSD}	Voltage at RA & C _{SSD} and Output pins	- 0.3	5	V
V _{OUTPUT}	Voltage at Gate Output	-0.3	6.5	V
V _{sense}	Voltage on Vsense pin	0	400	mV
T _J , T _{STG}	Operating and Storage Temperature Range	-40	150	°C
P _{max}	Maximum power dissipation (continuous) at T _C = 25 °C		0.625	W
R _{ΘJA}	Thermal Resistance junction–case (typical)		200	°C /W
V _{ESD} (pin to pin)	Electrostatic Discharge Voltage (Human Body Model) according to MIL STD 883D, method 3015.7 and EOS/ESD Assn. standard S5.1 - 1993		2	kV

Recommended Operating Conditions (*Reference load characteristics*)

The Recommended Operating Conditions table defines the conditions for actual device operation. Recommended operating conditions are specified to ensure optimal performance. Fairchild does not recommend exceeding them or designing to Absolute Maximum Ratings.

Symbol	Characteristic	Min.	Typ.	Max.	Units
I _{ctyp}	Collector (Coil) Operating Current		12		A
L _p	Coil Primary Inductance		1.5		mH
R _p	Coil Primary Resistance (25 °C)		0.4		Ω
R _{load}	Load Resistance (for delay time measurements)		2		Ω

Electrical Characteristics

Symbol	Parameter	Conditions	Min.	Typ.	Max.	Unit
Power Supply Conditions Vbat = 6 to 28 V ; TJ= -40 °C to 150 °C (unless otherwise specified)						
Vbat1	Operating voltage	Coil switching function	4		28	V
Vbat2	Operating voltage	All functions	6		28	V
Ibat	Supply current	TJ=150 °C, Vbat = 28 V, RA open, Input = 5 V			5	mA
Vclamp	Vbattery clamp	Ibatt = 10 mA	35		50	V
Sense Pin Conditions Vbat = 6 to 28 V ; TJ= -40 °C to 150 °C (unless otherwise specified)						
Vlimit	Sense Voltage at current limit	TJ = -40 °C to 150 °C (Vbat>8V)	185		215	mV
Vlimit	Sense Voltage at current limit	TJ = -40 °C to 150 °C (6V<Vbat<8V)	170			mV
Tspike	Input spike filter	Delay on rising and falling edge of Input		13		µs
TD1	Turn on delay time	50% at the input to 10% change at the output		15		µs
TD2	Turn off delay time	50% at the input to 10% change at the output		15		µs
Input Control Conditions Vbat = 6 to 28 V ; TJ= -40 °C to + 150 °C (unless otherwise specified)						
VINL	Input low voltage		1.2		1.7	V
VINH	Input high voltage		1.5		2	V
VINHys	Input voltage hysteresis		0.25		0.6	V
IIN	Input current (see fig 6)		0.5		15	mA
Gate Output Voltage Max Vbat = 6 to 28 V ; TJ= -40 °C to 150 °C (unless otherwise specified)						
Vgmax	Vgate max	16KΩ pulldown resistor	4.5	5.25	6	V
Vglow	Vgate low	(0mA<Igate<0.4mA @ T=25 °C)	0.0		0.2	V
Diagnostic Functions and Protection Vbat = 6 to 28 V ; TJ= -40 °C to 150 °C (unless otherwise specified)						
RA	Resistor for input reference current		5.2		200	kΩ
CSSDMIN	Minimum dwell time capacitor	Note 1		10		nF
TDMAX	Maximum dwell time	(CSSD=20 nF)	30		60	ms
ISLEW	Soft-Shut-Down slew rate	(Ic: 80-20%IClim)	0.7	1.5	2.5	A/ms
ICSSD1	CSSD Pin current for TDMAX		0.8	1.25	1.5	µA

Note 1. Refer to section Maximum dwell time and soft-shutdown (SSD)

Typical Performance Characteristics

Input and spike filter

When the input signal voltage reaches V_{INH} , the IGBT will be switched on charging the coil. When the input voltage goes below V_{INL} , the coil current through the IGBT will be turned off. If the FAN1100-F085 is in SSD mode, the input signal control is disabled. After an SSD sequence input control will be re-enabled after the input has reached a valid low. Positive and negative spikes of less than T_{spike} duration at the input line will be filtered out and will not turn on/off the IGBT.

Maximum dwell time and soft-shutdown (SSD)

When the IGBT is turned on, a delay timer, dependent on the value of the external CSSD capacitor (see Fig. 5), is started. If a valid falling edge has not been received after the time T_{DMAX} , the IGBT will be turned off slowly as shown in Fig. 4. The coil current will not exceed a slew rate of typical 1.5A/ms. (Based on ISL9V3040 Ignition IGBT). If a valid falling edge is received after the time T_{DMAX} , the edge will be ignored and the soft shutdown will be completed. The IGBT cannot be subsequently turned on until a valid rising edge is detected. If the CSSD capacitor has a value below 2.2 nF or the CSSD pin is shorted to ground, the maximum dwell time and SSD functions are disabled. The maximum dwell time is active for a capacitance value above 10 nF typical. The maxdwell might be indeterminate for capacitance value between 2.2 nF and 10 nF. The maximum dwell time is also disabled in case the input signal is set to high before or at the same time as the battery voltage. It is recommended to apply the battery voltage typically 50 us before the input signal goes high.

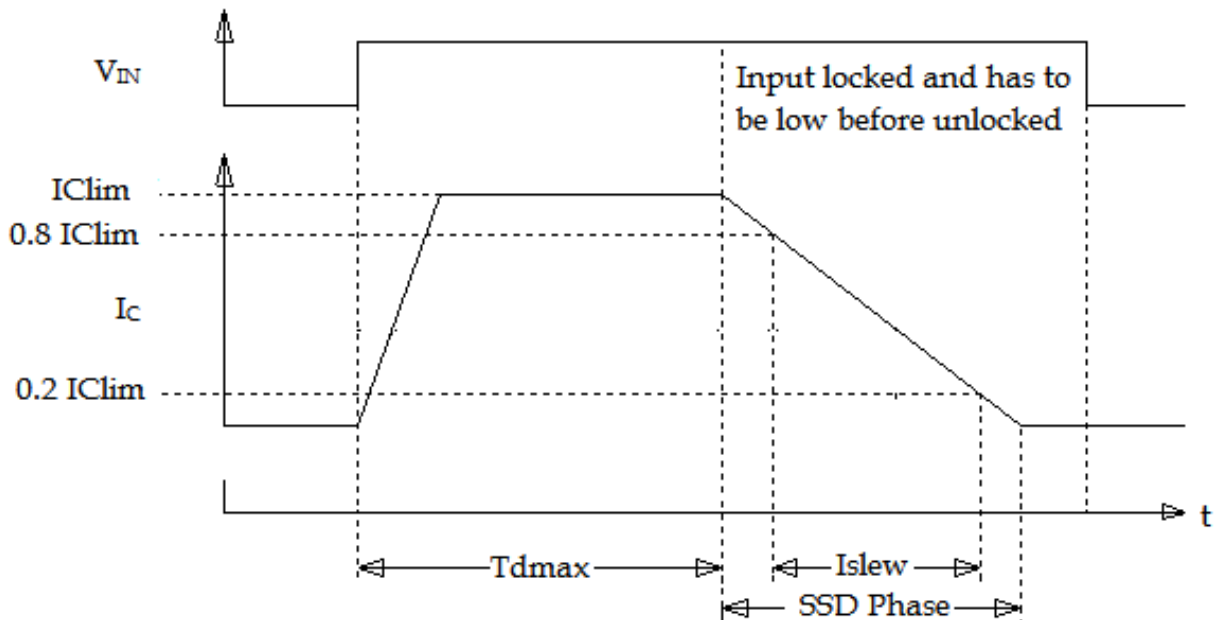

Figure 4: Dwell time and Soft-Shut-Down

Figure 5 shows the Relationship between the CSSD capacitor and Max Dwell Time

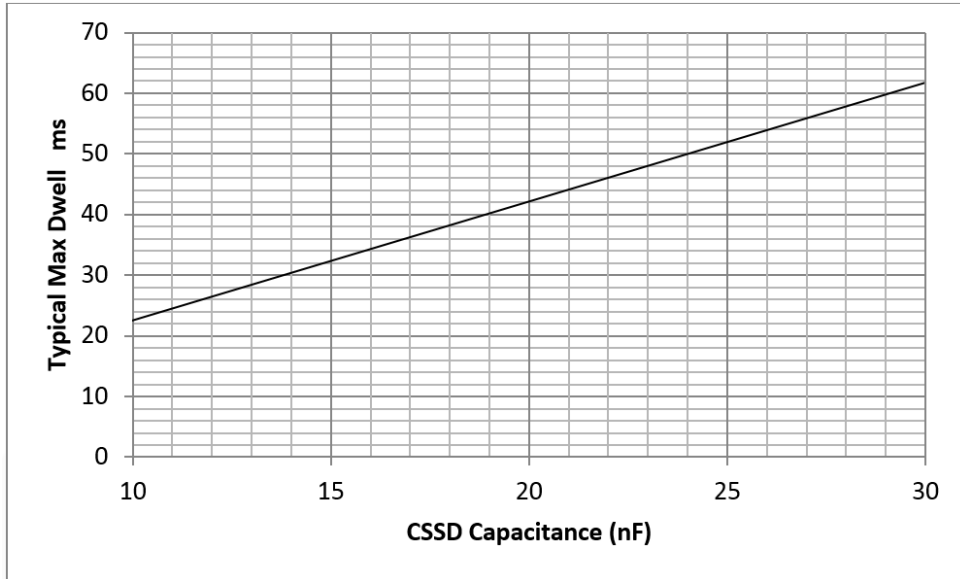

Figure 5: $T_{D_{MAX}}$ as function of external CSSD capacitor

Figure 6 shows the Signal input current vs. IRA current

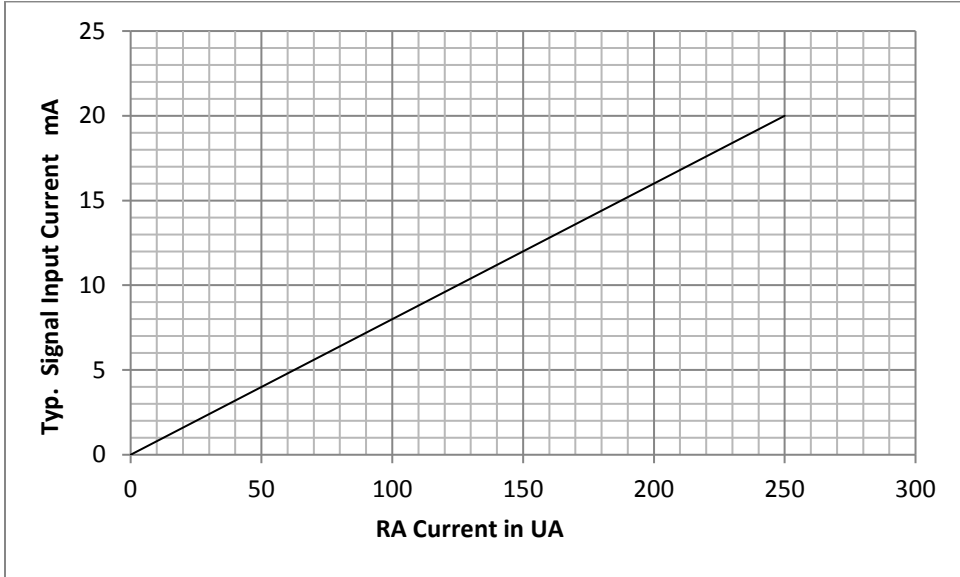

Figure 6: Interrelationship between Signal Input Current and IRA

Physical Dimensions

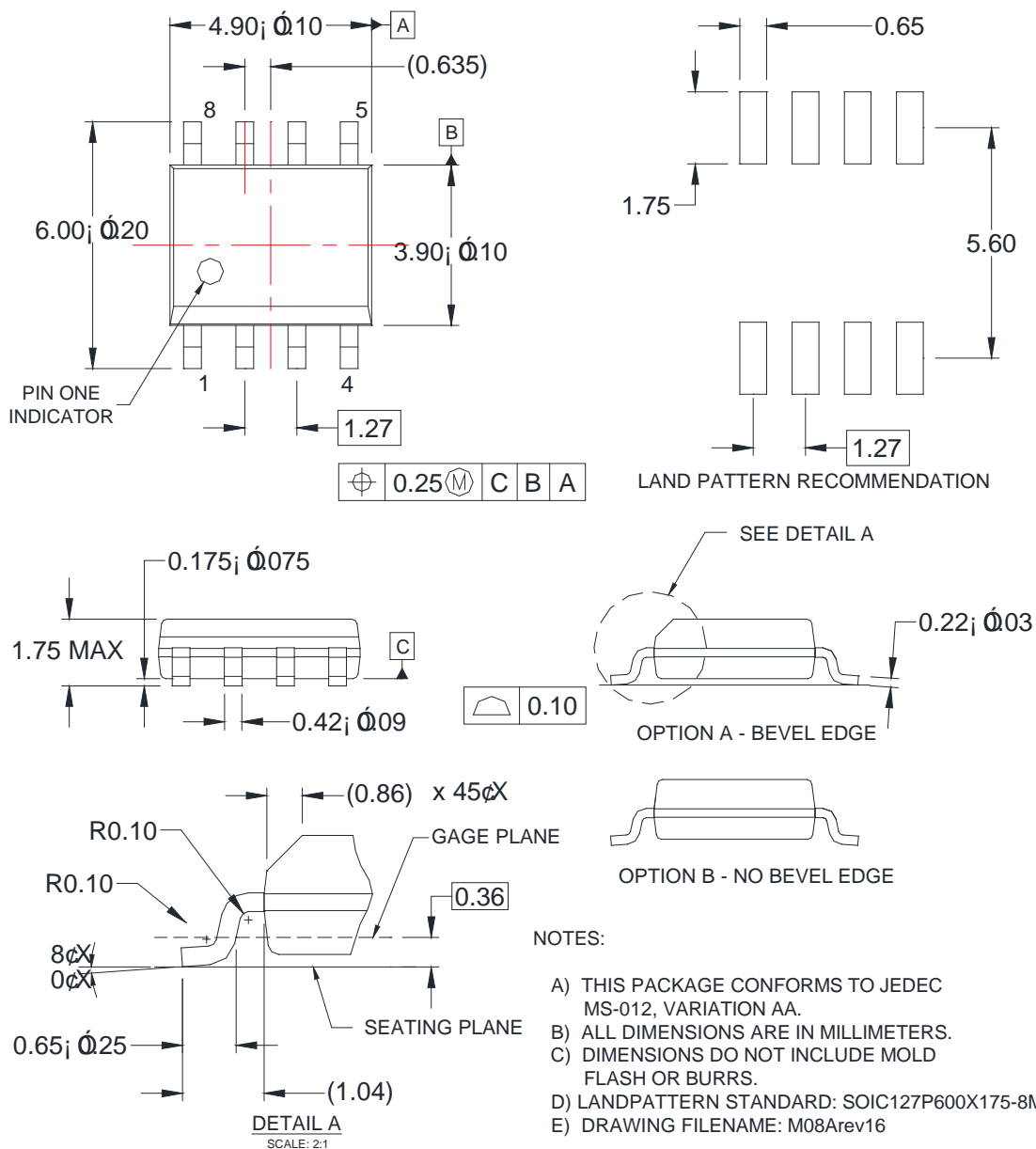

Figure 3. 8-Lead, Small-Outline Integrated Circuit (SOIC), JEDEC MS-012, .150-Inch, Narrow Body

ON Semiconductor and the ON Semiconductor logo are trademarks of Semiconductor Components Industries, LLC dba ON Semiconductor or its subsidiaries in the United States and/or other countries. ON Semiconductor owns the rights to a number of patents, trademarks, copyrights, trade secrets, and other intellectual property. A listing of ON Semiconductor's product/patent coverage may be accessed at www.onsemi.com/site/pdf/Patent-Marking.pdf. ON Semiconductor reserves the right to make changes without further notice to any products herein. ON Semiconductor makes no warranty, representation or guarantee regarding the suitability of its products for any particular purpose, nor does ON Semiconductor assume any liability arising out of the application or use of any product or circuit, and specifically disclaims any and all liability, including without limitation special, consequential or incidental damages. Buyer is responsible for its products and applications using ON Semiconductor products, including compliance with all laws, regulations and safety requirements or standards, regardless of any support or applications information provided by ON Semiconductor. "Typical" parameters which may be provided in ON Semiconductor data sheets and/or specifications can and do vary in different applications and actual performance may vary over time. All operating parameters, including "Typicals" must be validated for each customer application by customer's technical experts. ON Semiconductor does not convey any license under its patent rights nor the rights of others. ON Semiconductor products are not designed, intended, or authorized for use as a critical component in life support systems or any FDA Class 3 medical devices or medical devices with a same or similar classification in a foreign jurisdiction or any devices intended for implantation in the human body. Should Buyer purchase or use ON Semiconductor products for any such unintended or unauthorized application, Buyer shall indemnify and hold ON Semiconductor and its officers, employees, subsidiaries, affiliates, and distributors harmless against all claims, costs, damages, and expenses, and reasonable attorney fees arising out of, directly or indirectly, any claim of personal injury or death associated with such unintended or unauthorized use, even if such claim alleges that ON Semiconductor was negligent regarding the design or manufacture of the part. ON Semiconductor is an Equal Opportunity/Affirmative Action Employer. This literature is subject to all applicable copyright laws and is not for resale in any manner.

PUBLICATION ORDERING INFORMATION

LITERATURE FULFILLMENT:

Literature Distribution Center for ON Semiconductor
19521 E. 32nd Pkwy, Aurora, Colorado 80011 USA
Phone: 303-675-2175 or 800-344-3860 Toll Free USA/Canada
Fax: 303-675-2176 or 800-344-3867 Toll Free USA/Canada
Email: orderlit@onsemi.com

N. American Technical Support: 800-282-9855 Toll Free
USA/Canada.
Europe, Middle East and Africa Technical Support:
Phone: 421 33 790 2910
Japan Customer Focus Center
Phone: 81-3-5817-1050

ON Semiconductor Website: www.onsemi.com

Order Literature: <http://www.onsemi.com/orderlit>

For additional information, please contact your local
Sales Representative

Mouser Electronics

Authorized Distributor

Click to View Pricing, Inventory, Delivery & Lifecycle Information:

[onsemi:](#)

[FAN1100_F085](#) [FAN1100-F085](#)