

## DRV8843 Dual H-Bridge Driver

### 1 Features

- Dual H-Bridge Motor Driver
  - Single/Dual Brushed DC
  - Stepper
- IN/IN Control Interface
- Optional Fixed Frequency Current Regulation
  - Two Bit Current control Allows Up to Four Current Levels
- Low MOSFET On-Resistance
  - 2.5-A Maximum Drive Current at 24 V and  $T_A = 25^\circ\text{C}$
  - Combined 400 m $\Omega$   $R_{DS(ON)}$  of High-Side and Low-Side at 24 V and  $T_A = 25^\circ\text{C}$
- 8.2-V to 45-V Operating Supply Voltage Range
- Low Current Sleep Mode
- Built-In 3.3-V Reference Output
- Thermally Enhanced Surface Mount Package
- Protection Features
  - Overcurrent Protection (OCP)
  - Thermal Shutdown (TSD)
  - Undervoltage Lockout (UVLO)
  - Fault Condition Indication Pin (nFAULT)

### 2 Applications

- Printers
- Scanners
- Office Automation Machines
- Gaming Machines
- Factory Automation
- Robotics

### 3 Description

The DRV8843 provides an integrated dual H-bridge motor driver solution for printers, scanners, and other automated equipment applications. The device can be used to drive one or two brushed DC motors, a bipolar stepper motor, or other loads. A simple PWM interface allows easy interfacing to controller circuits.

The output driver block consists of N-channel power MOSFETs configured as H-bridges. The DRV8843 can supply up to 2.5-A peak or 1.75-A RMS output current (with proper heat sinking at 24 V and  $T_A = 25^\circ\text{C}$ ) per H-bridge.

A low-power sleep mode is provided which shuts down internal circuitry to achieve very low quiescent current draw. This sleep mode can be set using a dedicated nSLEEP pin.

Internal protection features are provided for overtemperature, overcurrent, and undervoltage. Fault conditions are indicated by a nFAULT pin.

#### Device Information<sup>(1)</sup>

PART NUMBER	PACKAGE	BODY SIZE (NOM)
DRV8843	HTSSOP (28)	9.70 mm x 4.40 mm

(1) For all available packages, see the orderable addendum at the end of the datasheet.

#### Simplified Schematic

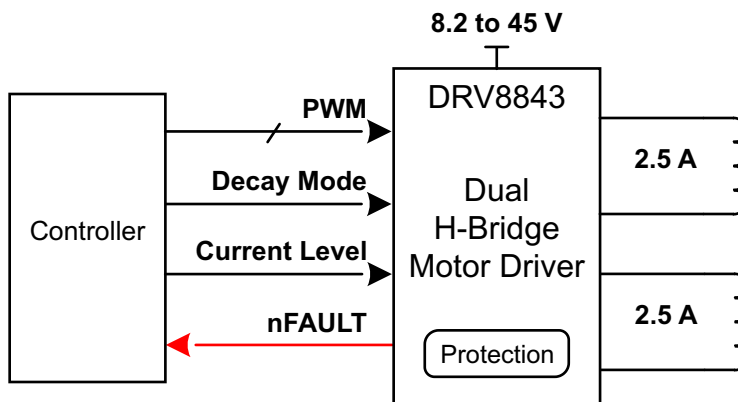

## Table of Contents

<b>1 Features</b> .....	<b>1</b>	<b>8 Application and Implementation</b> .....	<b>14</b>
<b>2 Applications</b> .....	<b>1</b>	8.1 Application Information.....	14
<b>3 Description</b> .....	<b>1</b>	8.2 Typical Application .....	14
<b>4 Revision History</b> .....	<b>2</b>	<b>9 Power Supply Recommendations</b> .....	<b>17</b>
<b>5 Pin Configuration and Functions</b> .....	<b>3</b>	9.1 Bulk Capacitance .....	17
<b>6 Specifications</b> .....	<b>5</b>	9.2 Power Supply and Logic Sequencing .....	17
6.1 Absolute Maximum Ratings .....	5	<b>10 Layout</b> .....	<b>18</b>
6.2 ESD Ratings.....	5	10.1 Layout Guidelines .....	18
6.3 Recommended Operating Conditions.....	5	10.2 Layout Example .....	18
6.4 Thermal Information .....	5	10.3 Thermal Considerations.....	19
6.5 Electrical Characteristics.....	6	<b>11 Device and Documentation Support</b> .....	<b>20</b>
6.6 Typical Characteristics.....	7	11.1 Documentation Support .....	20
<b>7 Detailed Description</b> .....	<b>8</b>	11.2 Community Resources.....	20
7.1 Overview .....	8	11.3 Trademarks .....	20
7.2 Functional Block Diagram .....	8	11.4 Electrostatic Discharge Caution.....	20
7.3 Feature Description.....	9	11.5 Glossary .....	20
7.4 Device Functional Modes.....	10	<b>12 Mechanical, Packaging, and Orderable Information</b> .....	<b>20</b>

## 4 Revision History

### Changes from Revision C (August 2013) to Revision D

Page

- Added *ESD Ratings* table, *Feature Description* section, *Device Functional Modes* section, *Application and Implementation* section, *Power Supply Recommendations* section, *Layout* section, *Device and Documentation Support* section, and *Mechanical, Packaging, and Orderable Information* section..... **3**

## 5 Pin Configuration and Functions

**PWP Package**  
**28-Pin HTSSOP with PowerPAD™**  
**Top View**

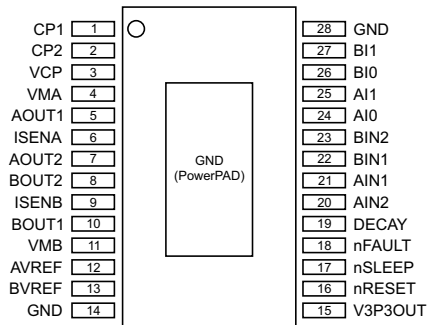

### Pin Functions

PIN		I/O <sup>(1)</sup>	DESCRIPTION	EXTERNAL COMPONENTS OR CONNECTIONS
NAME	PIN			
<b>POWER AND GROUND</b>				
GND	14, 28	-	Device ground	
VMA	4	-	Bridge A power supply	Connect to motor supply (8.2 V to 45 V). Both pins must be connected to the same supply, bypassed with a 0.1- $\mu$ F capacitor to GND, and connected to appropriate bulk capacitance.
VMB	11	-	Bridge B power supply	
V3P3OUT	15	O	3.3-V regulator output	Bypass to GND with a 0.47- $\mu$ F 6.3-V ceramic capacitor. Can be used to supply VREF.
CP1	1	IO	Charge pump flying capacitor	Connect a 0.01- $\mu$ F 50-V capacitor between CP1 and CP2.
CP2	2	IO	Charge pump flying capacitor	
VCP	3	IO	High-side gate drive voltage	Connect a 0.1- $\mu$ F 16-V ceramic capacitor and a 1-M $\Omega$ resistor to VM.
<b>CONTROL</b>				
AIN1	21	I	Bridge A input 1	Logic input controls state of AOUT1. Internal pulldown.
AIN2	20	I	Bridge A input 2	Logic input controls state of AOUT2. Internal pulldown.
AI0	24	I	Bridge A current set	Sets bridge A current: 00 = 100%, 01 = 71%, 10 = 38%, 11 = 0 Internal pulldown.
AI1	25	I		
BIN1	22	I	Bridge B input 1	Logic input controls state of BOUT1. Internal pulldown.
BIN2	23	I	Bridge B input 2	Logic input controls state of BOUT2. Internal pulldown.
BI0	26	I	Bridge B current set	Sets bridge B current: 00 = 100%, 01 = 71%, 10 = 38%, 11 = 0 Internal pulldown.
BI1	27	I		
DECAY	19	I	Decay mode	Low = slow decay, open = mixed decay, high = fast decay Internal pulldown and pullup.
nRESET	16	I	Reset input	Active-low reset input initializes internal logic and disables the H-bridge outputs. Internal pulldown.
nSLEEP	17	I	Sleep mode input	Logic high to enable device, logic low to enter low-power sleep mode. Internal pulldown.
AVREF	12	I	Bridge A current set reference input	Reference voltage for winding current set. Can be driven individually with an external DAC for microstepping, or tied to a reference (e.g., V3P3OUT).
BVREF	13	I	Bridge B current set reference input	
<b>STATUS</b>				
nFAULT	18	OD	Fault	Logic low when in fault condition (overtemp, overcurrent)

(1) Directions: I = input, O = output, OZ = tri-state output, OD = open-drain output, IO = input/output

**Pin Functions (continued)**

PIN		I/O <sup>(1)</sup>	DESCRIPTION	EXTERNAL COMPONENTS OR CONNECTIONS
NAME	PIN			
<b>OUTPUT</b>				
IENA	6	IO	Bridge A ground / Isense	Connect to current sense resistor for bridge A
IENB	9	IO	Bridge B ground / Isense	Connect to current sense resistor for bridge B
AOUT1	5	O	Bridge A output 1	Connect to motor winding A
AOUT2	7	O	Bridge A output 2	
BOUT1	10	O	Bridge B output 1	Connect to motor winding B
BOUT2	8	O	Bridge B output 2	

## 6 Specifications

### 6.1 Absolute Maximum Ratings

over operating free-air temperature range (unless otherwise noted) <sup>(1)(2)</sup>

		MIN	MAX	UNIT
Power supply voltage range	VMx	-0.3	47	V
Power supply ramp rate	VMx		1	V/μs
Digital pin voltage range		-0.5	7	V
Input voltage	VREF	-0.3	4	V
ISENSEx pin voltage <sup>(3)</sup>		-0.8	0.8	V
Peak motor drive output current, t < 1 μS		Internally limited		A
Continuous motor drive output current <sup>(4)</sup>		0	2.5	A
Continuous total power dissipation		See <a href="#">Thermal Information</a> .		
Operating virtual junction temperature range, T <sub>J</sub>		-40	150	°C
Operating ambient temperature range, T <sub>A</sub>		-40	85	°C
Storage Temperature, T <sub>STG</sub>		-60	150	°C

- (1) Stresses beyond those listed under absolute maximum ratings may cause permanent damage to the device. These are stress ratings only, and functional operation of the device at these or any other conditions beyond those indicated under recommended operating conditions is not implied. Exposure to absolute-maximum-rated conditions for extended periods may affect device reliability.
- (2) All voltage values are with respect to network ground terminal.
- (3) Transients of ±1 V for less than 25 ns are acceptable.
- (4) Power dissipation and thermal limits must be observed.

### 6.2 ESD Ratings

		VALUE	UNIT
V <sub>(ESD)</sub> Electrostatic discharge	Human-body model (HBM), per ANSI/ESDA/JEDEC JS-001 <sup>(1)</sup>	±2000	V
	Charged-device model (CDM), per JEDEC specification JESD22-C101 <sup>(2)</sup>	±500	

- (1) JEDEC document JEP155 states that 500-V HBM allows safe manufacturing with a standard ESD control process.
- (2) JEDEC document JEP157 states that 250-V CDM allows safe manufacturing with a standard ESD control process.

### 6.3 Recommended Operating Conditions

over operating free-air temperature range (unless otherwise noted)

		MIN	NOM	MAX	UNIT
V <sub>M</sub>	Motor power supply voltage range <sup>(1)</sup>	8.2		45	V
V <sub>REF</sub>	VREF input voltage <sup>(2)</sup>	1		3.5	V
I <sub>V3P3</sub>	V3P3OUT load current	0		1	mA
f <sub>PWM</sub>	Externally applied PWM frequency	0		100	kHz

- (1) All V<sub>M</sub> pins must be connected to the same supply voltage.
- (2) Operational at VREF between 0 V and 1 V, but accuracy is degraded.

### 6.4 Thermal Information

THERMAL METRIC <sup>(1)</sup>		DRV8843	UNIT
		PWP (HTSSOP)	
		28 PINS	
R <sub>θJA</sub>	Junction-to-ambient thermal resistance	31.6	°C/W
R <sub>θJC(top)</sub>	Junction-to-case (top) thermal resistance	15.9	°C/W
R <sub>θJB</sub>	Junction-to-board thermal resistance	5.6	°C/W
ψ <sub>JT</sub>	Junction-to-top characterization parameter	0.2	°C/W
ψ <sub>JB</sub>	Junction-to-board characterization parameter	5.5	°C/W
R <sub>θJC(bot)</sub>	Junction-to-case (bottom) thermal resistance	1.4	°C/W

- (1) For more information about traditional and new thermal metrics, see the *Semiconductor and IC Package Thermal Metrics* application report, [SPRA953](#).

## 6.5 Electrical Characteristics

over operating free-air temperature range (unless otherwise noted)

PARAMETER		TEST CONDITIONS	MIN	TYP	MAX	UNIT
<b>POWER SUPPLIES</b>						
$I_{VM}$	VM operating supply current	$V_M = 24\text{ V}$ , $f_{PWM} < 50\text{ kHz}$		5	8	mA
$I_{VMQ}$	VM sleep mode supply current	$V_M = 24\text{ V}$		10	20	$\mu\text{A}$
$V_{UVLO}$	VM undervoltage lockout voltage	$V_M$ rising		7.8	8.2	V
<b>V3P3OUT REGULATOR</b>						
$V_{3P3}$	V3P3OUT voltage	IOUT = 0 to 1 mA	3.2	3.3	3.4	V
<b>LOGIC-LEVEL INPUTS</b>						
$V_{IL}$	Input low voltage			0.6	0.7	V
$V_{IH}$	Input high voltage		2.2		5.25	V
$V_{HYS}$	Input hysteresis		0.3	0.45	0.6	V
$I_{IL}$	Input low current	$V_{IN} = 0$	-20		20	$\mu\text{A}$
$I_{IH}$	Input high current	$V_{IN} = 3.3\text{ V}$			100	$\mu\text{A}$
$R_{PD}$	Internal pulldown resistance			100		k $\Omega$
<b>nFAULT OUTPUT (OPEN-DRAIN OUTPUT)</b>						
$V_{OL}$	Output low voltage	$I_O = 5\text{ mA}$			0.5	V
$I_{OH}$	Output high leakage current	$V_O = 3.3\text{ V}$			1	$\mu\text{A}$
<b>DECAY INPUT</b>						
$V_{IL}$	Input low threshold voltage	For slow decay (brake) mode	0		0.8	V
$V_{IH}$	Input high threshold voltage	For fast decay (coast) mode	2			V
$I_{IN}$	Input current				$\pm 40$	$\mu\text{A}$
$R_{PU}$	Internal pullup resistance (to 3.3 V)			130		k $\Omega$
$R_{PD}$	Internal pulldown resistance			80		k $\Omega$
<b>H-BRIDGE FETS</b>						
$R_{DS(ON)}$	HS FET on resistance	$V_M = 24\text{ V}$ , $I_O = 1\text{ A}$ , $T_J = 25^\circ\text{C}$		0.2		$\Omega$
		$V_M = 24\text{ V}$ , $I_O = 1\text{ A}$ , $T_J = 85^\circ\text{C}$		0.25	0.32	
	LS FET on resistance	$V_M = 24\text{ V}$ , $I_O = 1\text{ A}$ , $T_J = 25^\circ\text{C}$		0.2		
		$V_M = 24\text{ V}$ , $I_O = 1\text{ A}$ , $T_J = 85^\circ\text{C}$		0.25	0.32	
$I_{OFF}$	Off-state leakage current		-20		20	$\mu\text{A}$
<b>MOTOR DRIVER</b>						
$f_{PWM}$	Internal current control PWM frequency			50		kHz
$t_{BLANK}$	Current sense blanking time			3.75		$\mu\text{s}$
$t_R$	Rise time		30		200	ns
$t_F$	Fall time		30		200	ns
<b>PROTECTION CIRCUITS</b>						
$I_{OCP}$	Overcurrent protection trip level		3			A
$t_{TSD}$	Thermal shutdown temperature	Die temperature	150	160	180	$^\circ\text{C}$
<b>CURRENT CONTROL</b>						
$I_{REF}$	VREF input current	$V_{REF} = 3.3\text{ V}$	-3		3	$\mu\text{A}$
$V_{TRIP}$	xISENSE trip voltage	$xV_{REF} = 3.3\text{ V}$ , 100% current setting	635	660	685	mV
		$xV_{REF} = 3.3\text{ V}$ , 71% current setting	445	469	492	
		$xV_{REF} = 3.3\text{ V}$ , 38% current setting	225	251	276	
$A_{ISENSE}$	Current sense amplifier gain	Reference only		5		V/V

### 6.6 Typical Characteristics

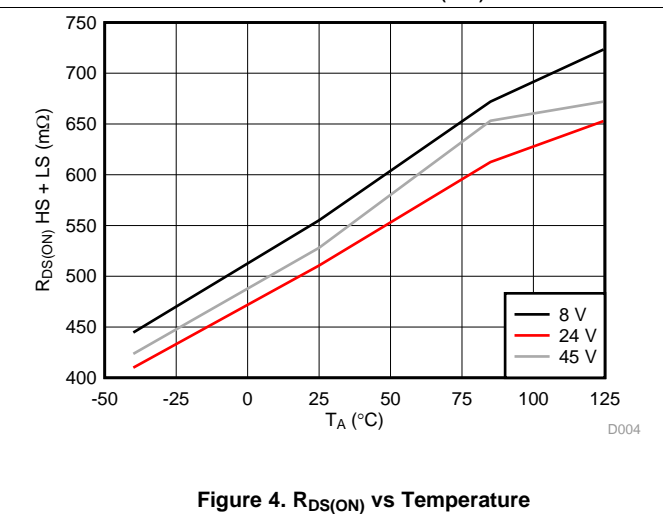
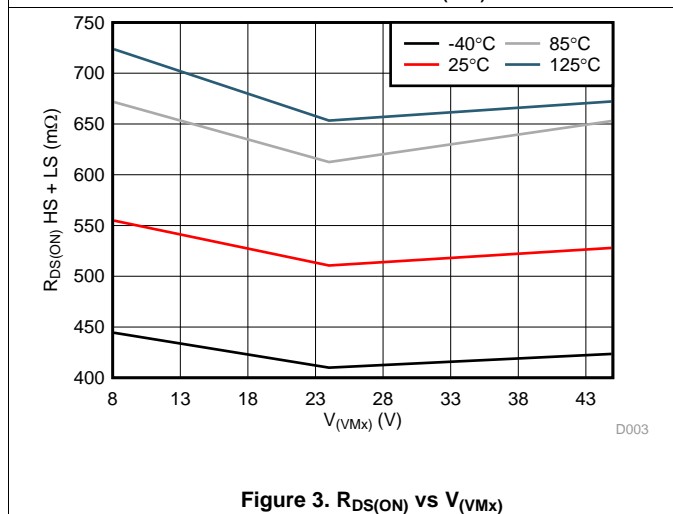
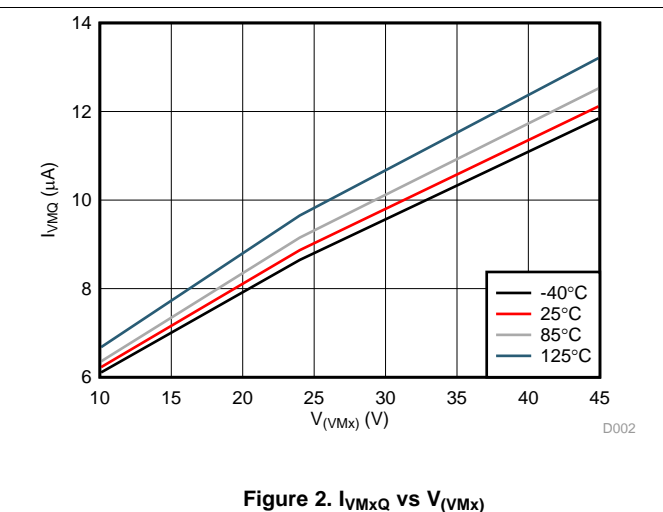
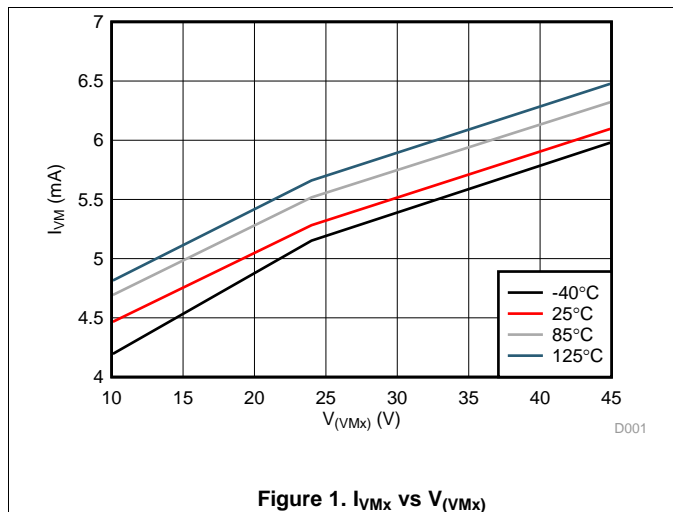

## 7 Detailed Description

### 7.1 Overview

The DRV8843 is an integrated motor driver solution for two brushed DC motors or a bipolar stepper motor. The device integrates two power NMOS H-bridges, current sense and regulation circuitry, protection devices, and a digital interface.

A simple PWM interface allows for easy interfacing to an external digital controller and requires minimal resources. The fault indication pin (nFAULT) provides a flag for when the device has entered a fault state.

The current regulation is highly configurable with three modes of operation. Depending on the applications requirements the device can be configured for fast, slow, or mixed decay. Two bit current level control allows the device to switch between four different current levels.

A low-power sleep mode is implemented which allows the system to save power when not driving the motor.

### 7.2 Functional Block Diagram

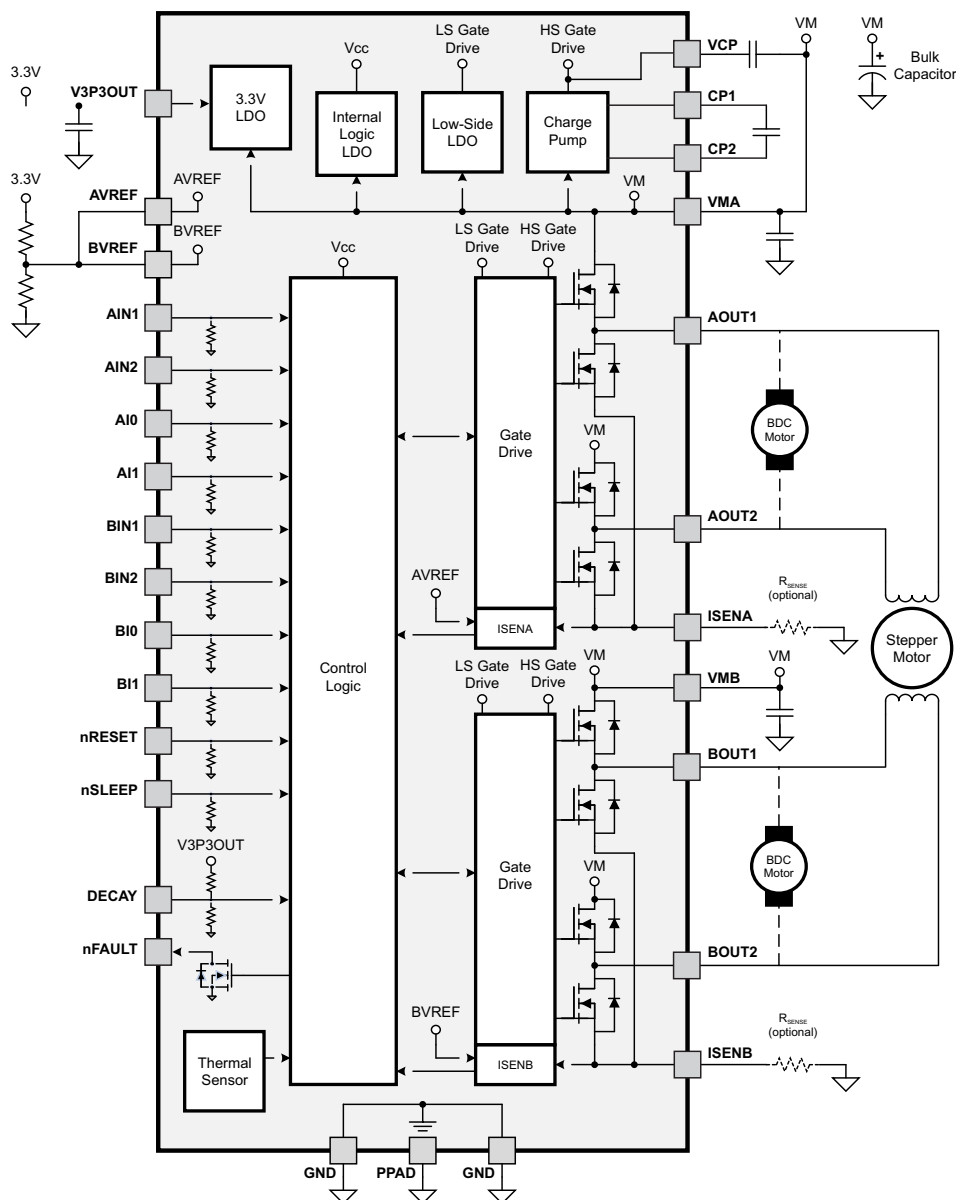



## 7.3 Feature Description

### 7.3.1 PWM Motor Drivers

The DRV8843 contains two H-bridge motor drivers with current-control PWM circuitry. A block diagram of the motor control circuitry is shown in [Figure 5](#).

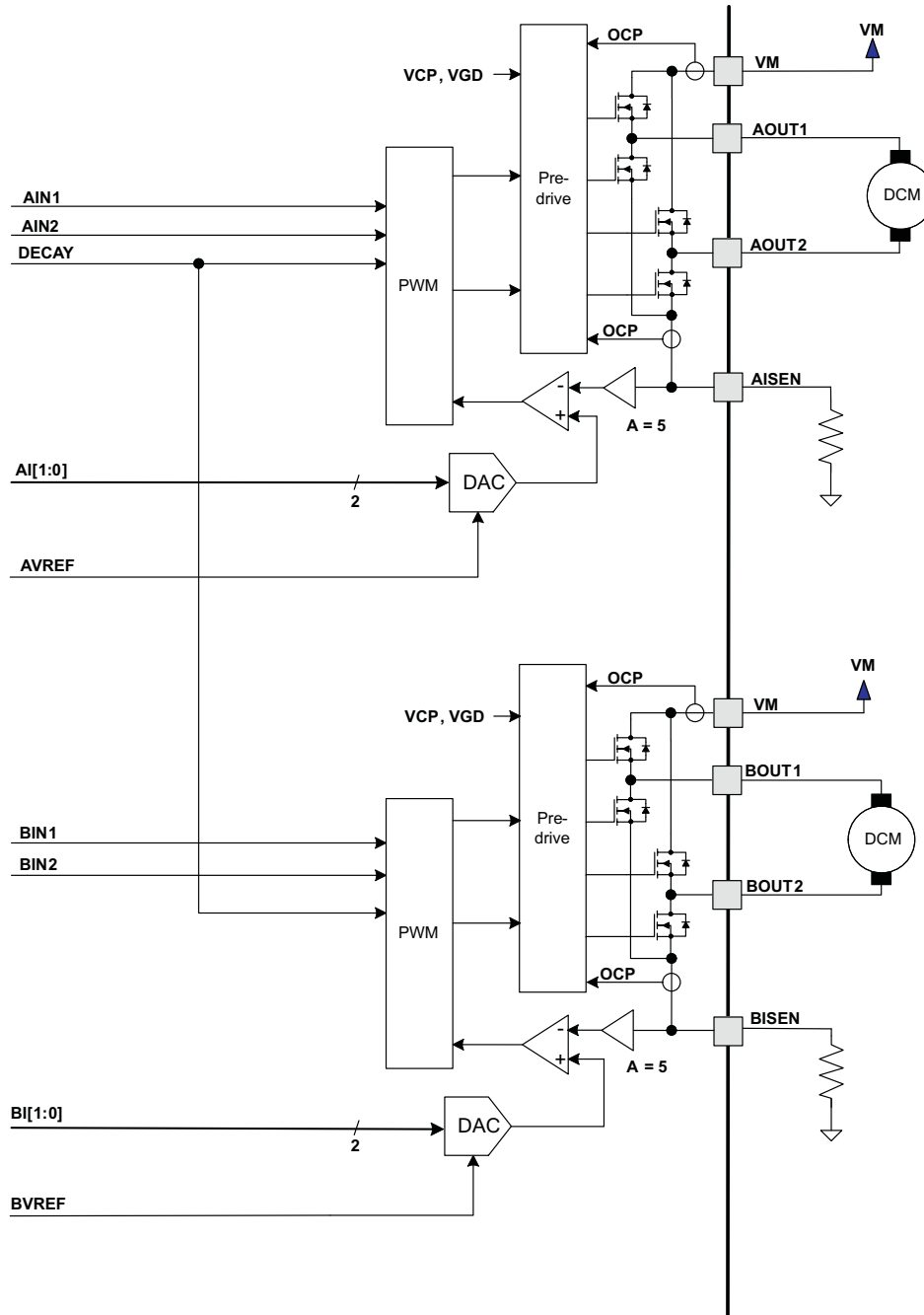

**Figure 5. Motor Control Circuitry**

**NOTE**

There are multiple VM pins. All VM pins must be connected together to the motor supply voltage.

## 7.4 Device Functional Modes

### 7.4.1 Bridge Control

The AIN1 and AIN2 input pins directly control the state of the AOUT1 and AOUT2 outputs; similarly, the BIN1 and BIN2 input pins directly control the state of the BOUT1 and BOUT2 outputs. Either input can also be used for PWM control of the load. [Table 1](#) shows the logic.

**Table 1. H-Bridge Logic**

xIN1	xIN2	xOUT1	xOUT2
0	0	Z	Z
0	1	L	H
1	0	H	L
1	1	L	L

The inputs can also be used for PWM control of the motor speed. When controlling a winding with PWM, when the drive current is interrupted, the inductive nature of the motor requires that the current continue to flow. This is called recirculation current. To handle this recirculation current, the H-bridge can operate in two different states, fast decay or slow decay. In fast decay mode, the H-bridge is disabled and recirculation current flows through the body diodes; in slow decay, the motor winding is shorted.

To PWM using fast decay, the PWM signal is applied to one xIN pin while the other is held low; to use slow decay, one xIN pin is held high.

The control inputs have internal pulldown resistors of approximately 100 kΩ.

**Table 2. PWM Function**

xIN1	xIN2	FUNCTION
PWM	0	Forward PWM, fast decay
1	PWM	Forward PWM, slow decay
0	PWM	Reverse PWM, fast decay
PWM	1	Reverse PWM, slow decay

[Figure 6](#) shows the current paths in different drive and decay modes.

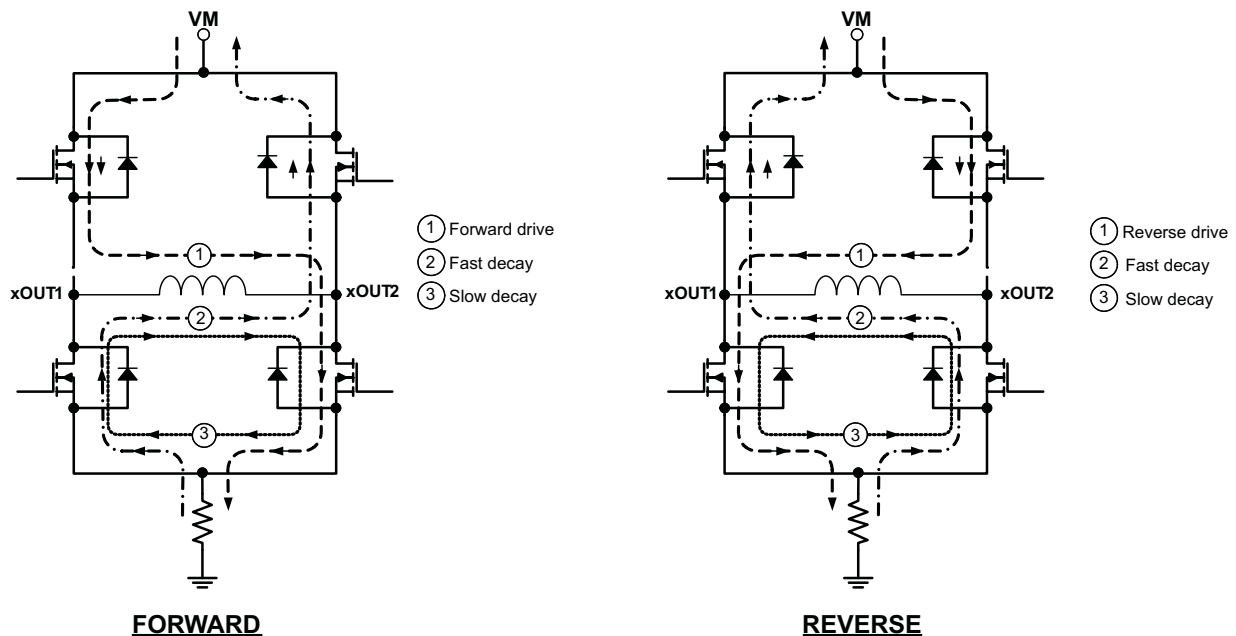

**Figure 6. Current Paths**

### 7.4.2 Current Regulation

The current through the motor windings is regulated by a fixed-frequency PWM current regulation, or current chopping. When an H-bridge is enabled, current rises through the winding at a rate dependent on the DC voltage and inductance of the winding. Once the current hits the current chopping threshold, the bridge disables the current until the beginning of the next PWM cycle.

For stepping motors, current regulation is normally used at all times, and can changing the current can be used to microstep the motor. For DC motors, current regulation is used to limit the start-up and stall current of the motor.

If the current regulation feature is not needed, it can be disabled by connecting the xISENSE pins directly to ground and connecting the xVREF pins to V3P3.

The PWM chopping current is set by a comparator which compares the voltage across a current sense resistor connected to the xISEN pins, multiplied by a factor of 5, with a reference voltage. The reference voltage is input from the xVREF pins, and is scaled by a 2-bit DAC that allows current settings of 100%, 71%, 38% of full-scale, plus zero.

The full-scale (100%) chopping current is calculated in [Equation 1](#).

$$I_{\text{CHOP}} = \frac{V_{\text{REFX}}}{5 \times R_{\text{ISENSE}}} \quad (1)$$

Example:

If a 0.25-Ω sense resistor is used and the VREFx pin is 2.5 V, the full-scale (100%) chopping current will be 2.5 V / (5 × 0.25 Ω) = 2 A.

Two input pins per H-bridge (x11 and x10) are used to scale the current in each bridge as a percentage of the full-scale current set by the VREF input pin and sense resistance. The x10 and x11 pins have internal pulldown resistors of approximately 100 kΩ. The function of the pins is shown in [Table 3](#).

**Table 3. H-Bridge Pin Functions**

x11	x10	RELATIVE CURRENT (% FULL-SCALE CHOPPING CURRENT)
1	1	0% (Bridge disabled)
1	0	38%
0	1	71%
0	0	100%

#### NOTE

When both xl bits are 1, the H-bridge is disabled and no current flows.

Example:

If a 0.25-Ω sense resistor is used and the VREF pin is 2.5 V, the chopping current will be 2 A at the 100% setting (x11, x10 = 00). At the 71% setting (x11, x10 = 01) the current will be 2 A × 0.71 = 1.42 A, and at the 38% setting (x11, x10 = 10) the current will be 2 A × 0.38 = 0.76 A. If (x11, x10 = 11) the bridge will be disabled and no current will flow.

### 7.4.3 Decay Mode During Current Chopping

During PWM current chopping, the H-bridge is enabled to drive current through the motor winding until the PWM current chopping threshold is reached. This is shown in [Figure 7](#) as case 1. The current flow direction shown indicates the state when the xIN1 pin is high and the xIN2 pin is low.

Once the chopping current threshold is reached, the H-bridge can operate in two different states, fast decay or slow decay.

In fast decay mode, once the PWM chopping current level has been reached, the H-bridge reverses state to allow winding current to flow in a reverse direction. As the winding current approaches zero, the bridge is disabled to prevent any reverse current flow. Fast decay mode is shown in [Figure 7](#) as case 2.

In slow decay mode, winding current is re-circulated by enabling both of the low-side FETs in the bridge. This is shown in [Figure 7](#) as case 3.

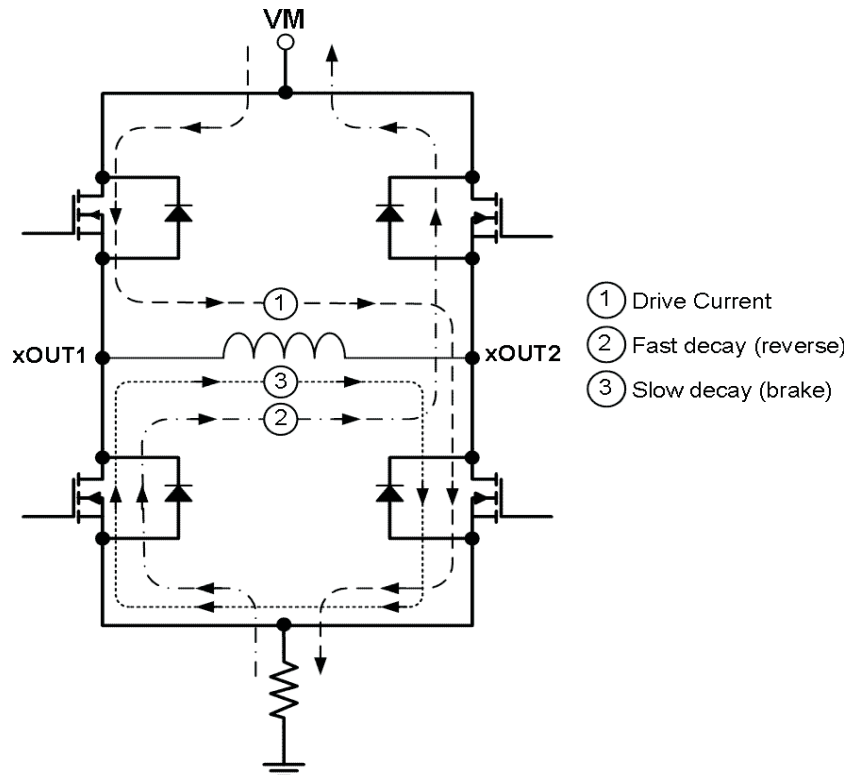

**Figure 7. Decay Mode**

The DRV8843 supports fast decay, slow decay and a mixed decay mode during current chopping. Slow, fast, or mixed decay mode is selected by the state of the DECAY pin - logic low selects slow decay, open selects mixed decay operation, and logic high sets fast decay mode. The DECAY pin has both an internal pullup resistor of approximately 130-k $\Omega$  and an internal pulldown resistor of approximately 80-k $\Omega$ . This sets the mixed decay mode if the pin is left open or undriven. Note that the DECAY pin sets the decay mode for both H-bridges.

Mixed decay mode begins as fast decay, but at a fixed period of time (75% of the PWM cycle) switches to slow decay mode for the remainder of the fixed PWM period.

#### 7.4.4 Blanking Time

After the current is enabled in an H-bridge, the voltage on the xISEN pin is ignored for a fixed period of time before enabling the current sense circuitry. This blanking time is fixed at 3.75  $\mu$ s. Note that the blanking time also sets the minimum on time of the PWM.

#### 7.4.5 nRESET and nSLEEP Operation

The nRESET pin, when driven active low, resets the internal logic. It also disables the H-bridge drivers. All inputs are ignored while nRESET is active.

Driving nSLEEP low will put the device into a low power sleep state. In this state, the H-bridges are disabled, the gate drive charge pump is stopped, the V3P3OUT regulator is disabled, and all internal clocks are stopped. In this state all inputs are ignored until nSLEEP returns inactive high. When returning from sleep mode, some time (approximately 1 ms) needs to pass before the motor driver becomes fully operational. Note that nRESET and nSLEEP have internal pulldown resistors of approximately 100 k $\Omega$ . These signals need to be driven to logic high for device operation.

## 7.4.6 Protection Circuits

The DRV8843 is fully protected against undervoltage, overcurrent and overtemperature events.

### 7.4.6.1 Overcurrent Protection (OCP)

An analog current limit circuit on each FET limits the current through the FET by removing the gate drive. If this analog current limit persists for longer than the OCP time, all FETs in the H-bridge will be disabled and the nFAULT pin will be driven low. The device will remain disabled until either nRESET pin is applied, or VM is removed and re-applied.

Overcurrent conditions on both high and low side devices; i.e., a short to ground, supply, or across the motor winding will all result in an overcurrent shutdown. Note that overcurrent protection does not use the current sense circuitry used for PWM current control, and is independent of the  $I_{SENSE}$  resistor value or VREF voltage.

### 7.4.6.2 Thermal Shutdown (TSD)

If the die temperature exceeds safe limits, all FETs in the H-bridge will be disabled and the nFAULT pin will be driven low. Once the die temperature has fallen to a safe level operation will automatically resume.

### 7.4.6.3 Undervoltage Lockout (UVLO)

If at any time the voltage on the VM pins falls below the undervoltage lockout threshold voltage, all circuitry in the device will be disabled and internal logic will be reset. Operation will resume when  $V_M$  rises above the UVLO threshold.

## 8 Application and Implementation

### NOTE

Information in the following applications sections is not part of the TI component specification, and TI does not warrant its accuracy or completeness. TI's customers are responsible for determining suitability of components for their purposes. Customers should validate and test their design implementation to confirm system functionality.

### 8.1 Application Information

The DRV8843 can be used to control a bipolar stepper motor. The PWM interface controls the outputs and current control can be implemented with the internal current regulation circuitry. Detailed fault reporting is provided with the internal protection circuits and nFAULT pin.

### 8.2 Typical Application

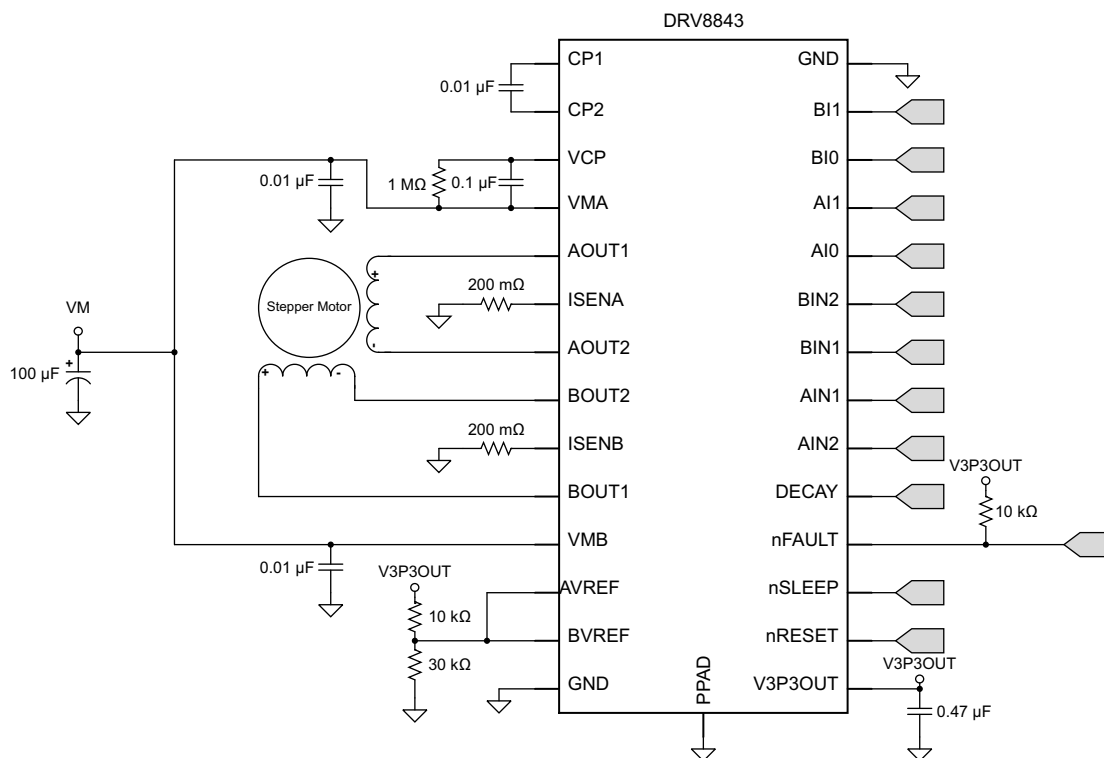

Figure 8. Typical Application Schematic

#### 8.2.1 Design Requirements

Specific parameters for designing a dual brushed DC motor drive system.

Table 4. Design Parameters

DESIGN PARAMETER	REFERENCE	EXAMPLE VALUE
Supply Voltage	VM	24 V
Motor Winding Resistance	$R_L$	3.9 $\Omega$
Motor Winding Inductance	$I_L$	2.9 mH
Sense Resistor Value	$R_{SENSE}$	200 m $\Omega$
Target Full-Scale Current	$I_{FS}$	1.25 A

## 8.2.2 Detailed Design Procedure

### 8.2.2.1 Current Regulation

In a stepper motor, the set full-scale current ( $I_{FS}$ ) is the maximum current driven through either winding. This quantity depends on the xVREF analog voltage and the sense resistor value ( $R_{SENSE}$ ). During stepping,  $I_{FS}$  defines the current chopping threshold ( $I_{TRIP}$ ) for the maximum current step. The gain of DRV8843 is set for 5 V/V.

$$I_{FS} (A) = \frac{xVREF(V)}{A_V \times R_{SENSE} (\Omega)} = \frac{xVREF(V)}{5 \times R_{SENSE} (\Omega)} \quad (2)$$

To achieve  $I_{FS} = 1.25$  A with  $R_{SENSE}$  of 0.2  $\Omega$ , xVREF should be 1.25 V.

### 8.2.2.2 Decay Modes

The DRV8843 supports three different decay modes: slow decay, fast decay, and mixed decay. The current through the motor windings is regulated using a fixed-frequency PWM scheme. This means that after any drive phase, when a motor winding current has hit the current chopping threshold ( $I_{TRIP}$ ), the DRV8843 will place the winding in one of the three decay modes until the PWM cycle has expired. Afterward, a new drive phase starts.

The blanking time,  $t_{BLANK}$ , defines the minimum drive time for the current chopping.  $I_{TRIP}$  is ignored during  $t_{BLANK}$ , so the winding current may overshoot the trip level.

### 8.2.2.3 Sense Resistor

For optimal performance, it is important for the sense resistor to be:

- Surface-mount
- Low inductance
- Rated for high enough power
- Placed closely to the motor driver

The power dissipated by the sense resistor equals  $I_{rms}^2 \times R$ . For example, if the rms motor current is 2-A and a 100-m  $\Omega$  sense resistor is used, the resistor will dissipate  $2 A^2 \times 0.1 \Omega = 0.4$  W. The power quickly increases with greater current levels.

Resistors typically have a rated power within some ambient temperature range, along with a de-rated power curve for high ambient temperatures. When a PCB is shared with other components generating heat, margin should be added. It is always best to measure the actual sense resistor temperature in a final system, along with the power MOSFETs, as those are often the hottest components.

Because power resistors are larger and more expensive than standard resistors, it is common practice to use multiple standard resistors in parallel, between the sense node and ground. This distributes the current and heat dissipation.

### 8.2.3 Application Curves

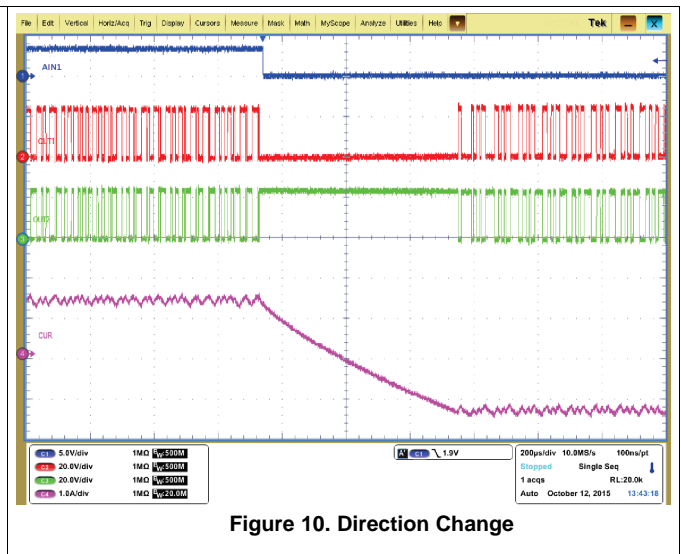
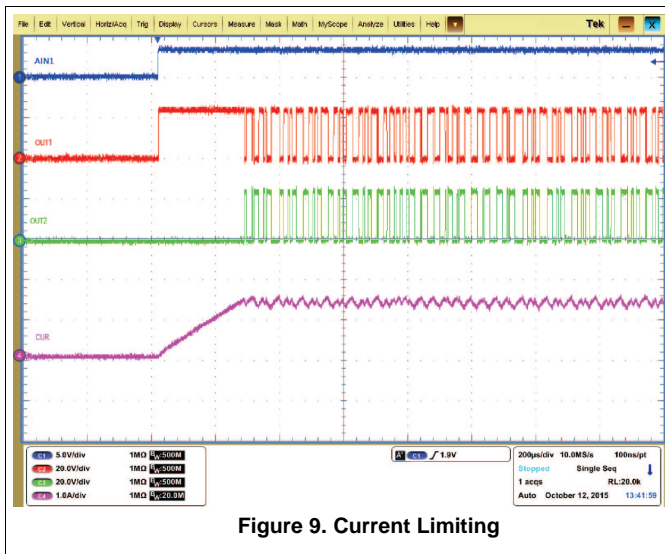



## 9 Power Supply Recommendations

The DRV8843 is designed to operate from an input voltage supply (VMx) range between 8.2 and 45 V. Two 0.1- $\mu$ F ceramic capacitors rated for VMx must be placed as close as possible to the VMA and VMB pins respectively (one on each pin). In addition to the local decoupling caps, additional bulk capacitance is required and must be sized accordingly to the application requirements.

### 9.1 Bulk Capacitance

Bulk capacitance sizing is an important factor in motor drive system design. It is dependent on a variety of factors including:

- Type of power supply
- Acceptable supply voltage ripple
- Parasitic inductance in the power supply wiring
- Type of motor (brushed DC, brushless DC, stepper)
- Motor startup current
- Motor braking method

The inductance between the power supply and motor drive system will limit the rate current can change from the power supply. If the local bulk capacitance is too small, the system will respond to excessive current demands or dumps from the motor with a change in voltage. You should size the bulk capacitance to meet acceptable voltage ripple levels.

The data sheet generally provides a recommended value but system level testing is required to determine the appropriate sized bulk capacitor.

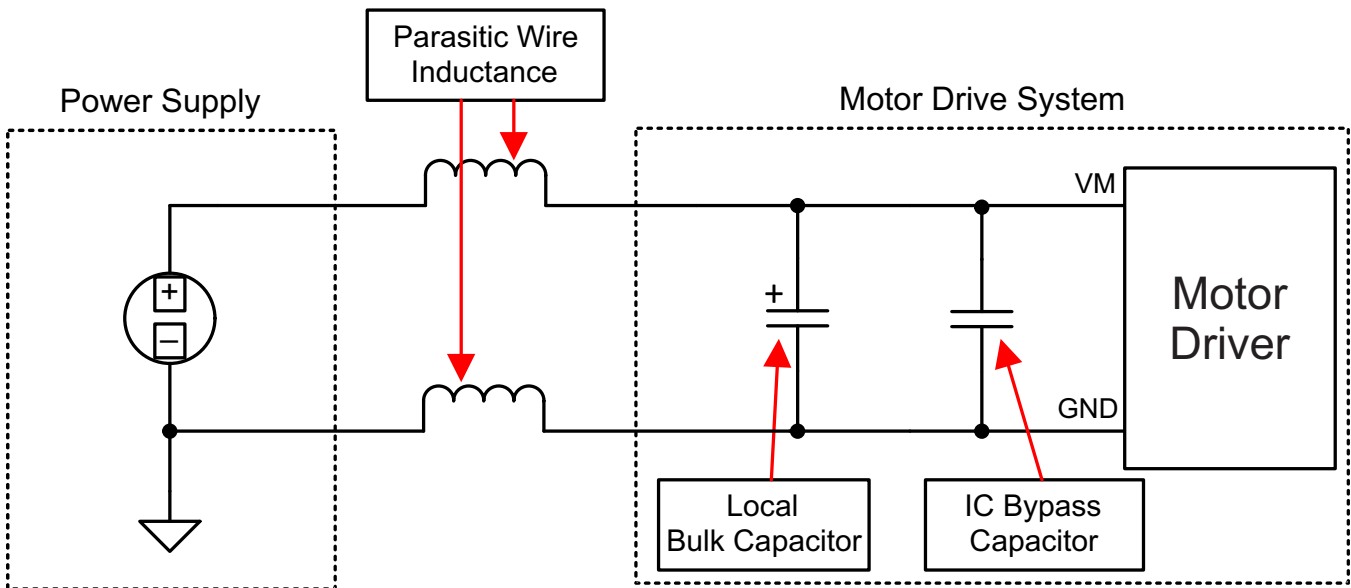

Figure 11. Setup of Motor Drive System With External Power Supply

### 9.2 Power Supply and Logic Sequencing

There is no specific sequence for powering-up the DRV8843. It is okay for digital input signals to be present before VMx is applied. After VMx is applied to the device, it begins operation based on the status of the control pins.

## 10 Layout

### 10.1 Layout Guidelines

The VMA and VMB pins should be bypassed to GND using low-ESR ceramic bypass capacitors with a recommended value of 0.1- $\mu$ F rated for VMx. This capacitor should be placed as close to the VMA and VMB pins as possible with a thick trace or ground plane connection to the device GND pin.

The VMA and VMB pins must be bypassed to ground using an appropriate bulk capacitor. This component may be an electrolytic and should be located close to the DRV8843.

A low-ESR ceramic capacitor must be placed in between the CPL and CPH pins. TI recommends a value of 0.01- $\mu$ F rated for VMx. Place this component as close to the pins as possible.

A low-ESR ceramic capacitor must be placed in between the VMA and VCP pins. TI recommends a value of 0.1- $\mu$ F rated for 16 V. Place this component as close to the pins as possible. Also, place a 1-M $\Omega$  resistor between VCP and VMA.

Bypass V3P3 to ground with a ceramic capacitor rated 6.3 V. Place this bypass capacitor as close to the pin as possible

### 10.2 Layout Example

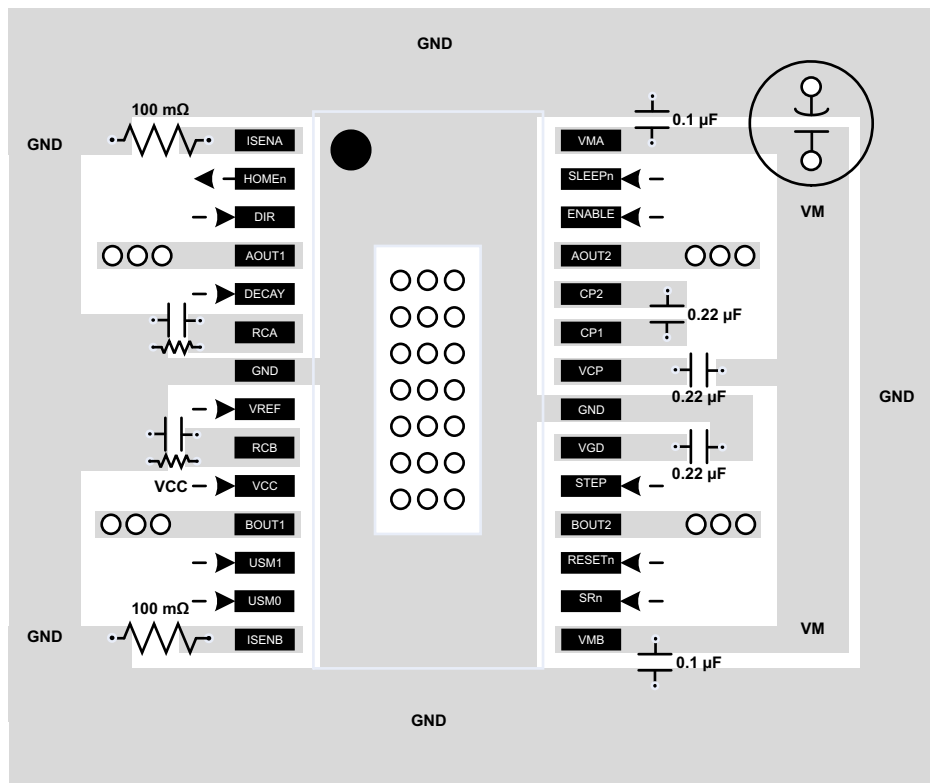

Figure 12. DRV8843 Layout Example

## 10.3 Thermal Considerations

### 10.3.1 Thermal Protection

The DRV8843 has thermal shutdown (TSD) as described in [Thermal Shutdown \(TSD\)](#). If the die temperature exceeds approximately 150°C, the device will be disabled until the temperature drops to a safe level.

Any tendency of the device to enter TSD is an indication of either excessive power dissipation, insufficient heatsinking, or too high an ambient temperature.

### 10.3.2 Power Dissipation

Power dissipation in the DRV8843 is dominated by the power dissipated in the output FET resistance, or  $R_{DS(ON)}$ . Average power dissipation of each H-bridge when running a DC motor can be roughly estimated by [Equation 3](#).

$$P = 2 \times R_{DS(ON)} \times (I_{OUT})^2$$

where

- P is the power dissipation of one H-bridge
- $R_{DS(ON)}$  is the resistance of each FET
- $I_{OUT}$  is the RMS output current being applied to each winding (3)

$I_{OUT}$  is equal to the average current drawn by the DC motor. Note that at start-up and fault conditions this current is much higher than normal running current; these peak currents and their duration also need to be taken into consideration. The factor of 2 comes from the fact that at any instant two FETs are conducting winding current (one high-side and one low-side).

The total device dissipation will be the power dissipated in each of the two H-bridges added together.

The maximum amount of power that can be dissipated in the device is dependent on ambient temperature and heatsinking.

---

#### NOTE

$R_{DS(ON)}$  increases with temperature, so as the device heats, the power dissipation increases. This must be taken into consideration when sizing the heatsink.

---

### 10.3.3 Heatsinking

The PowerPAD™ package uses an exposed pad to remove heat from the device. For proper operation, this pad must be thermally connected to copper on the PCB to dissipate heat. On a multi-layer PCB with a ground plane, this can be accomplished by adding a number of vias to connect the thermal pad to the ground plane. On PCBs without internal planes, copper area can be added on either side of the PCB to dissipate heat. If the copper area is on the opposite side of the PCB from the device, thermal vias are used to transfer the heat between top and bottom layers.

For details about how to design the PCB, refer to TI application report *PowerPAD™ Thermally Enhanced Package*, [SLMA002](#), and TI application brief *PowerPAD™ Made Easy*, [SLMA004](#), available at [www.ti.com](http://www.ti.com).

In general, the more copper area that can be provided, the more power can be dissipated.

## 11 Device and Documentation Support

### 11.1 Documentation Support

#### 11.1.1 Related Documentation

For related documentation see the following:

- *PowerPAD™ Thermally Enhanced Package*, [SLMA002](#)
- *PowerPAD™ Made Easy*, [SLMA004](#)

### 11.2 Community Resources

The following links connect to TI community resources. Linked contents are provided "AS IS" by the respective contributors. They do not constitute TI specifications and do not necessarily reflect TI's views; see TI's [Terms of Use](#).

**TI E2E™ Online Community** *TI's Engineer-to-Engineer (E2E) Community*. Created to foster collaboration among engineers. At [e2e.ti.com](#), you can ask questions, share knowledge, explore ideas and help solve problems with fellow engineers.

**Design Support** *TI's Design Support* Quickly find helpful E2E forums along with design support tools and contact information for technical support.

### 11.3 Trademarks

PowerPAD, E2E are trademarks of Texas Instruments.  
All other trademarks are the property of their respective owners.

### 11.4 Electrostatic Discharge Caution



These devices have limited built-in ESD protection. The leads should be shorted together or the device placed in conductive foam during storage or handling to prevent electrostatic damage to the MOS gates.

### 11.5 Glossary

[SLYZ022](#) — *TI Glossary*.

This glossary lists and explains terms, acronyms, and definitions.

## 12 Mechanical, Packaging, and Orderable Information

The following pages include mechanical, packaging, and orderable information. This information is the most current data available for the designated devices. This data is subject to change without notice and revision of this document. For browser-based versions of this data sheet, refer to the left-hand navigation.

**PACKAGING INFORMATION**

Orderable Device	Status (1)	Package Type	Package Drawing	Pins	Package Qty	Eco Plan (2)	Lead finish/ Ball material (6)	MSL Peak Temp (3)	Op Temp (°C)	Device Marking (4/5)	Samples
DRV8843PWP	ACTIVE	HTSSOP	PWP	28	50	RoHS & Green	NIPDAU	Level-3-260C-168 HR	-40 to 85	DRV8843	<a href="#">Samples</a>
DRV8843PWPR	ACTIVE	HTSSOP	PWP	28	2000	RoHS & Green	NIPDAU	Level-3-260C-168 HR	-40 to 85	DRV8843	<a href="#">Samples</a>

(1) The marketing status values are defined as follows:

**ACTIVE:** Product device recommended for new designs.

**LIFEBUY:** TI has announced that the device will be discontinued, and a lifetime-buy period is in effect.

**NRND:** Not recommended for new designs. Device is in production to support existing customers, but TI does not recommend using this part in a new design.

**PREVIEW:** Device has been announced but is not in production. Samples may or may not be available.

**OBSOLETE:** TI has discontinued the production of the device.

(2) **RoHS:** TI defines "RoHS" to mean semiconductor products that are compliant with the current EU RoHS requirements for all 10 RoHS substances, including the requirement that RoHS substance do not exceed 0.1% by weight in homogeneous materials. Where designed to be soldered at high temperatures, "RoHS" products are suitable for use in specified lead-free processes. TI may reference these types of products as "Pb-Free".

**RoHS Exempt:** TI defines "RoHS Exempt" to mean products that contain lead but are compliant with EU RoHS pursuant to a specific EU RoHS exemption.

**Green:** TI defines "Green" to mean the content of Chlorine (Cl) and Bromine (Br) based flame retardants meet JS709B low halogen requirements of <=1000ppm threshold. Antimony trioxide based flame retardants must also meet the <=1000ppm threshold requirement.

(3) MSL, Peak Temp. - The Moisture Sensitivity Level rating according to the JEDEC industry standard classifications, and peak solder temperature.

(4) There may be additional marking, which relates to the logo, the lot trace code information, or the environmental category on the device.

(5) Multiple Device Markings will be inside parentheses. Only one Device Marking contained in parentheses and separated by a "~" will appear on a device. If a line is indented then it is a continuation of the previous line and the two combined represent the entire Device Marking for that device.

(6) Lead finish/Ball material - Orderable Devices may have multiple material finish options. Finish options are separated by a vertical ruled line. Lead finish/Ball material values may wrap to two lines if the finish value exceeds the maximum column width.

**Important Information and Disclaimer:**The information provided on this page represents TI's knowledge and belief as of the date that it is provided. TI bases its knowledge and belief on information provided by third parties, and makes no representation or warranty as to the accuracy of such information. Efforts are underway to better integrate information from third parties. TI has taken and continues to take reasonable steps to provide representative and accurate information but may not have conducted destructive testing or chemical analysis on incoming materials and chemicals. TI and TI suppliers consider certain information to be proprietary, and thus CAS numbers and other limited information may not be available for release.

In no event shall TI's liability arising out of such information exceed the total purchase price of the TI part(s) at issue in this document sold by TI to Customer on an annual basis.



## TAPE AND REEL INFORMATION



### QUADRANT ASSIGNMENTS FOR PIN 1 ORIENTATION IN TAPE



\*All dimensions are nominal

Device	Package Type	Package Drawing	Pins	SPQ	Reel Diameter (mm)	Reel Width W1 (mm)	A0 (mm)	B0 (mm)	K0 (mm)	P1 (mm)	W (mm)	Pin1 Quadrant
DRV8843PWPR	HTSSOP	PWP	28	2000	330.0	16.4	6.9	10.2	1.8	12.0	16.0	Q1

**TAPE AND REEL BOX DIMENSIONS**



\*All dimensions are nominal

Device	Package Type	Package Drawing	Pins	SPQ	Length (mm)	Width (mm)	Height (mm)
DRV8843PWPR	HTSSOP	PWP	28	2000	350.0	350.0	43.0



## GENERIC PACKAGE VIEW

**PWP 28**

**PowerPAD™ TSSOP - 1.2 mm max height**

4.4 x 9.7, 0.65 mm pitch

SMALL OUTLINE PACKAGE

This image is a representation of the package family, actual package may vary.  
Refer to the product data sheet for package details.

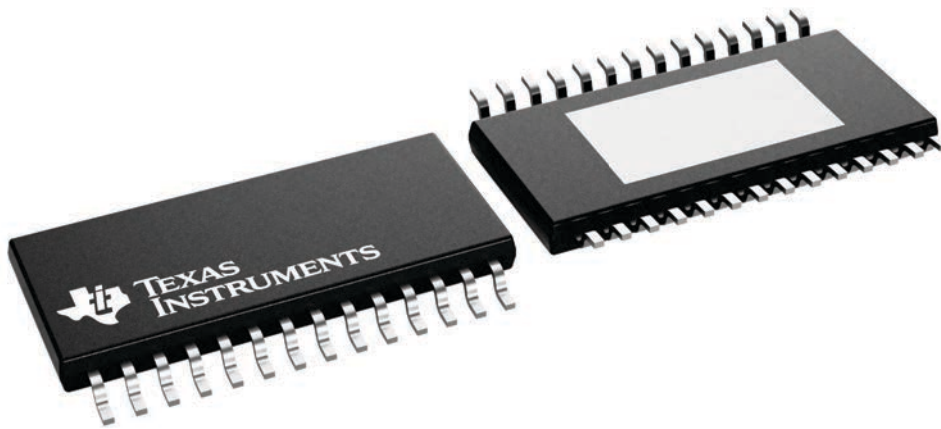

4224765/B

# PWP0028C

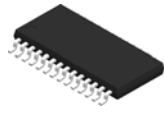

# PACKAGE OUTLINE

## PowerPAD™ TSSOP - 1.2 mm max height

SMALL OUTLINE PACKAGE

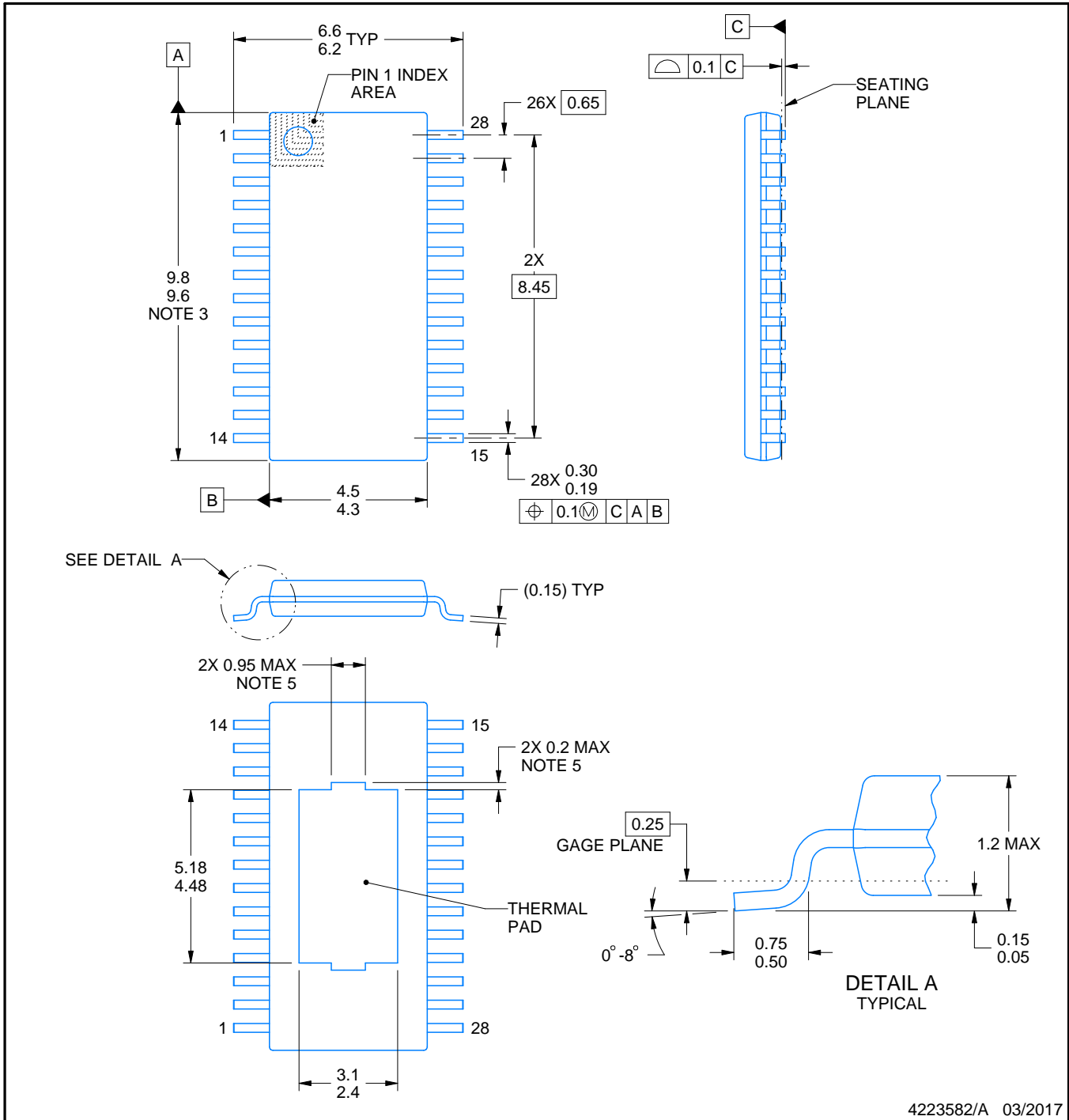

4223582/A 03/2017

### NOTES:

PowerPAD is a trademark of Texas Instruments.

1. All linear dimensions are in millimeters. Any dimensions in parenthesis are for reference only. Dimensioning and tolerancing per ASME Y14.5M.
2. This drawing is subject to change without notice.
3. This dimension does not include mold flash, protrusions, or gate burrs. Mold flash, protrusions, or gate burrs shall not exceed 0.15 mm per side.
4. Reference JEDEC registration MO-153.
5. Features may differ or may not be present.



# EXAMPLE STENCIL DESIGN

PWP0028C

PowerPAD™ TSSOP - 1.2 mm max height

SMALL OUTLINE PACKAGE

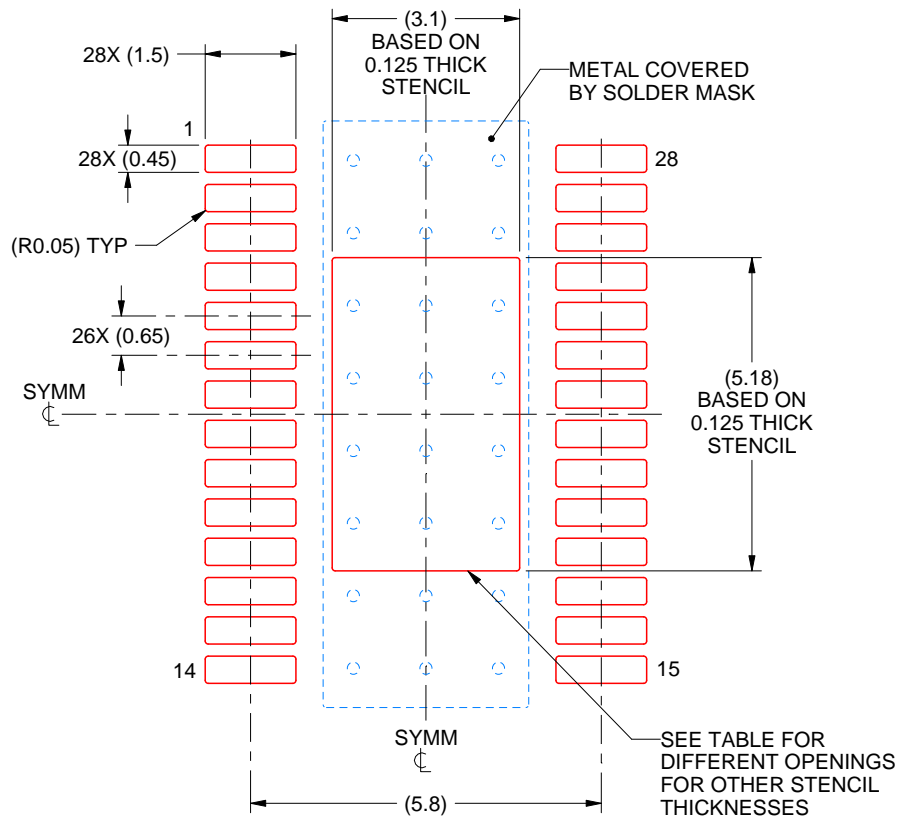

**SOLDER PASTE EXAMPLE**  
 BASED ON 0.125 mm THICK STENCIL  
 SCALE: 8X

STENCIL THICKNESS	SOLDER STENCIL OPENING
0.1	3.47 X 5.79
0.125	3.10 X 5.18 (SHOWN)
0.15	2.83 X 4.73
0.175	2.62 X 4.38

4223582/A 03/2017

NOTES: (continued)

11. Laser cutting apertures with trapezoidal walls and rounded corners may offer better paste release. IPC-7525 may have alternate design recommendations.
12. Board assembly site may have different recommendations for stencil design.

## IMPORTANT NOTICE AND DISCLAIMER

TI PROVIDES TECHNICAL AND RELIABILITY DATA (INCLUDING DATASHEETS), DESIGN RESOURCES (INCLUDING REFERENCE DESIGNS), APPLICATION OR OTHER DESIGN ADVICE, WEB TOOLS, SAFETY INFORMATION, AND OTHER RESOURCES "AS IS" AND WITH ALL FAULTS, AND DISCLAIMS ALL WARRANTIES, EXPRESS AND IMPLIED, INCLUDING WITHOUT LIMITATION ANY IMPLIED WARRANTIES OF MERCHANTABILITY, FITNESS FOR A PARTICULAR PURPOSE OR NON-INFRINGEMENT OF THIRD PARTY INTELLECTUAL PROPERTY RIGHTS.

These resources are intended for skilled developers designing with TI products. You are solely responsible for (1) selecting the appropriate TI products for your application, (2) designing, validating and testing your application, and (3) ensuring your application meets applicable standards, and any other safety, security, or other requirements. These resources are subject to change without notice. TI grants you permission to use these resources only for development of an application that uses the TI products described in the resource. Other reproduction and display of these resources is prohibited. No license is granted to any other TI intellectual property right or to any third party intellectual property right. TI disclaims responsibility for, and you will fully indemnify TI and its representatives against, any claims, damages, costs, losses, and liabilities arising out of your use of these resources.

TI's products are provided subject to TI's Terms of Sale ([www.ti.com/legal/termsofsale.html](http://www.ti.com/legal/termsofsale.html)) or other applicable terms available either on [ti.com](http://ti.com) or provided in conjunction with such TI products. TI's provision of these resources does not expand or otherwise alter TI's applicable warranties or warranty disclaimers for TI products.

Mailing Address: Texas Instruments, Post Office Box 655303, Dallas, Texas 75265  
Copyright © 2020, Texas Instruments Incorporated