



Extract from our online catalogue:

bks-3/CIU

Current to: 2021-12-16



The bks edge sensor facilitates the contact-free web edge scanning of foils, paper and other soundimpermeable materials.

HIGHLIGHTS

- › Compact design with only 30 mm fork width
- › 0.025 mm resolution
- › 0.1 mm relative accuracy
- › 4 ms response time
- › 8 mm working range

BASICS

- › Contact-free detection of the path edge
- › Analogue output 4–20 mA and 0–10 V
- › 3 LEDs and 1 button on the top of the housing
- › Parameterisable with LinkControl
- › Robust metal housing › for harsh usage conditions

Description

The bks ultrasonic edge sensor

is a fork sensor for scanning the edges of sound-impermeable materials such as foil or paper.

This is why the bks is ideally suited for the web control of highly transparent foils, light-sensitive materials, materials with greatly varying transparency and paper subject to high paper dust loads.

The functional principle

The fork's lower leg is equipped with an ultrasonic transmitter which cyclically emits short sound impulses, which are detected by the ultrasonic receiver arranged in the upper fork leg. Material passing through the fork covers this sound path and thus attenuates the receiving signal depending on the coverage, which is evaluated by the internal electronics. An analogue signal is output in dependence of the coverage degree.



The analogue output can both deliver voltage 0–10 V as well as current 4–20 mA.

The operating range amounts to 8 mm (± 4 mm).

Via the Teach-in button

on the edge sensor's top, the zero position of the edge to be controlled is set. There are two options for calibration:

- › completely freeing the fork from the web material,
- › pressing the button for approx. 3 seconds until the two yellow LEDs flash alternately. Ready. Or
- › aligning the web edge inside the fork with the two marks to ensure a 50% coverage of the sound path,
- › then pressing the button for approx. 10 seconds until the two yellow LEDs remain lit. Ready.

The bks edge sensor has a fork width of 30 mm and a fork depth of 33 mm. Other fork widths and depths are available upon request. The housing side is equipped with two consistent bores for the edge sensor's mounting. The electrical connection is established via an M12 circular connector.

Three LEDs

indicate the position of the web material inside the fork. For the application of light-sensitive materials, the LEDs can also be switched off.

The bks is pre-set and immediately ready for operation. Optionally, it can also be comprehensively parameterised with the help of the [LinkControl adapter LCA-2](#) and [LinkControl software](#) .

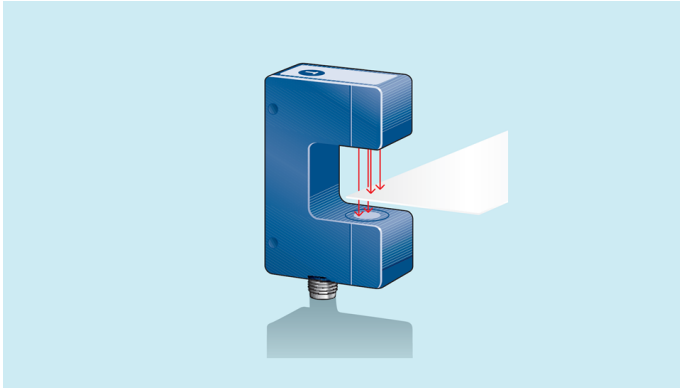

With a fork width of only 30 mm and a depth of 33 mm, it has a very compact design. Its working range of 8 mm and its high accuracy of 0.1 mm permit a wide variety of applications.

bks-3/CIU

scale drawing

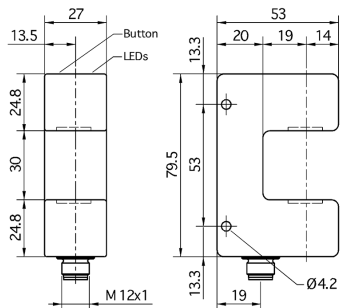

detection zone



1 x analogue 4-20 mA + 0-10 V

working range	8 mm (± 4 mm)
design	fork-like
operating mode	path edge detection

ultrasonic-specific

means of measurement	pulse operation with amplitude evaluation
transducer frequency	200 kHz
blind zone	7 mm in front of transmitter and receiver
resolution	0.025 mm
reproducibility	± 0.1 mm at constant ambient conditions

electrical data

operating voltage U_B	20 - 30 V d.c., reverse polarity protection
voltage ripple	± 10 %
no-load current consumption	≤ 50 mA
type of connection	5-pin M12 initiator plug

bks-3/CIU

outputs

output 1	analogue output current: 4-20 mA / voltage: 0-10 V, short-circuit-proof switchable rising/falling
response time	2 ms
delay prior to availability	< 300 ms

inputs

description	deactivated: $U_E > 9$ V DC; activated: $< U_E < 4$ V DC or control input open
input 1	com input enable input

housing

fork width	30 mm
fork depth	33 mm
material	aluminium anodized
ultrasonic transducer	polyurethane foam, epoxy resin with glass contents
class of protection to EN 60529	IP 65
operating temperature	+5°C to +60°C
storage temperature	-40°C to +85°C
weight	140 g
further versions	larger fork width/depth

technical features/characteristics

controls	1 push-button
scope for settings	Teach-in via push-button LCA-2 with LinkControl
Synchronisation	no
multiplex	no
indicators	1 x LED green: center position, 2 x LED yellow: deviation from center position

bks-3/CIU

pin assignment

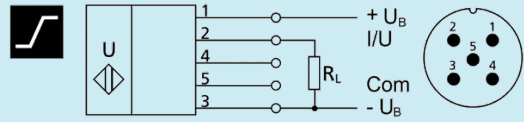

order no.

bks-3/CIU

The content of this document is subject to technical changes.
Specifications in this document are presented in a descriptive way
only. They do not warrant any product features.