

UR4848xA

Universal Controller



User manual

Revision D; July 2018

Table of contents

1	Introduction	5
2	Safety guide lines	5
3	Model Identification	5
4	Technical Data	5
4.1	General Features	5
4.2	Hardware Features	6
4.3	Software Features	6
5	Dimensions and Installation	7
6	Electrical wirings	7
6.1	Wiring diagram	8
7	Display and Key Functions	12
7.1	Numeric Indicators (Display)	12
7.2	Meaning of Status Lights (Led)	12
7.3	Keys	12
8	Dual input mode	13
8.1	Selection of process value related to the command output and to the alarms	13
8.2	Remote setpoint by analogue input	13
8.3	Remote setpoint by serial input	14
9	Controller Functions	14
9.1	Modification of main and alarm setpoint value	14
9.2	Automatic Tune	14
9.3	Manual Tune	14
9.4	Tuning once	15
9.5	Synchronized tuning	15
9.6	Digital input functions	15
9.7	Automatic / Manual regulation for % output control	16
9.8	Heater Break Alarm on CT (current transformer - only on UR48482A / 3A /4A)	16
9.9	Dual Action (Heating-Cooling)	17
9.10	LATCH ON Function	18
9.11	Soft-Start Function	19
9.12	Pre-Programmed cycle	19
9.13	Retransmission function on analogue output	19
10	Serial communication	20
11	Reading and configuration through NFC	25
12	Access configuration	26
12.1	Loading default values	26
12.2	Parameters list functioning	26
13	Table of Configuration Parameters	27
14	Alarm Intervention Modes	63
15	Table of Anomaly Signals	65

1 Introduction

The process controller UR4848xA stands out for the bright display which ensures optimal visibility and increased level of information for the operator beside a scrolling Help function.

The process controller UR4848xA relies on Wachendorff flagship programming mode by NFC/RFID technology with dedicated App Wachendorff EMG for Android devices, not requiring wirings and power supply, allowing quick set-up/updates on site. Availability include a model with dual analogue input and dual analogue output for maximum flexibility of applications. It is possible to achieve two separate heating/cooling PID control loops in one device or to handle mathematical operations between two process values.

The outputs can be selected as command/multiple alarm modes/analogue retransmission. Serial communication standard is RS485 with Modbus RTU/Slave protocol. Useful power supply with extended range 24 to 230VAC / VDC with galvanic insulation of the net for the single loop version, while the model with double analogue input provides two versions: 115 / 230 VAC or 24 VAC / VDC.

2 Safety guide lines

Read carefully the safety guidelines and programming instructions contained in this manual before using/connecting the device. Disconnect power supply before proceeding to hardware settings or electrical wirings. Only qualified personnel should be allowed to use the device and/or service it and in accordance to technical data and environmental conditions listed in this manual.

Do not dispose electric tools together with household waste material.

In observance European Directive 2002/96/EC on waste electrical and electronic equipment and its implementation in accordance with national law, electric tools that have reached the end of their life must be collected separately and returned to an environmentally compatible recycling facility.

3 Model Identification

The UR4848xA series includes 4 versions:

Models with power supply 24..230 VAC/VDC $\pm 15\%$ 50/60 Hz – 6 Watt/VA

UR4841A	1 analogue input + 2 relays 2 A + 2 SSR + 2 D.I. + 1 analogue output V/mA
UR48482A	1 analogue input + 2 relays 2 A + 2 SSR / D.I. + 1 analogue output V/mA + RS485

Model with power supply 24 VAC/VDC $\pm 15\%$ 50/60 Hz – 6 Watt/VA

UR48483A	2 analogue input + 3 relays 2 A + 2 SSR + 2/4 D.I. + 2 analogue output V/mA + RS485 + CT
----------	--

Model with power supply 115..230 VAC $\pm 15\%$ 50/60 Hz – 6 Watt/VA

UR48484A	2 analogue input + 3 relays 2 A + 2 SSR + 2/4 D.I. + 2 analogue output V/mA + RS485 + CT
----------	--

4 Technical Data

4.1 General Features

Displays	4 digits 0,52", 5 digits 0,30"
Operating temperature	Temperature: 0-45° C -Humidity 35..95 uR%
Sealing	IP65 front panel (with gasket) IP20 box and terminals
Material	Box and front panel: PC UL94V2 self-extinguishing
Weight	Approx. 185 g

4.2 Hardware Features

AI1 – AI2:

Configurable via software.

Input: Thermocouple

type K, S, R, J, T, E, N, B.

Automatic compensation of cold junction from -25...85°C.

Analogue inputs

Thermoresistances: PT100, PT500, PT1000, Ni100, PTC 1K, NTC 10K (β 3435K)

Input V/mA: 0-1 V, 0-5 V, 0-10 V, 0-20 V, 4-20 mA, 0-60 mV.

Pot. Input: 1...150 KΩ.

CT: 50 mA.

Tolerance (25°C)

+/-0.2% ±1 digit (on F.s.) for thermocouple, thermoresistance and V/mA.

Cold junction accuracy 0.1°C/°C.

Impedance:

0-10 V: Ri>110 KΩ

0-20 mA: Ri<5 Ω

0-40 mV: Ri>1 MΩ

Relay outputs

Configurable as command and alarm output.

Contacts:
2 A - 250 VAC Resistive load.

SSR output

Configurable as command and alarm output.

12/24 V, 25 mA.

Analogue outputs

Configurable as command and alarm output or as retransmission of process / setpoints.

Configurable:
0-10 V with 40000 points +/-0.2% (on F.s.)
4-20 mA con 40000 points +/-0.2% (on F.s.)

Power-supply

For UR48481A and UR4842A:

Extended power-supply 24..230 VAC/
VDC ±15% 50/60 Hz

For UR48483A:

24 VAC/VDC ±15% 50/60 Hz

For UR48484A:

115..230 VAC ±15% 50/60 Hz

For UR4841A and UR48482A:

Consumption: 6 Watt/VA

For UR48483A and UR48484A:

Consumption: 6 Watt/VA

4.3 Software Features

Regulation algorithms	ON-OFF with hysteresis. P, PI, PID, PD with proportional time
Proportional band	0..9999°C o °F
Integral time	0,0..999,9 sec (0 excludes)
Derivative time	0,0..999,9 sec (0 excludes)
Controller functions	Manual or automatic Tuning, selectable alarm, protection of command and alarm setpoints.

5

Dimensions and Installation

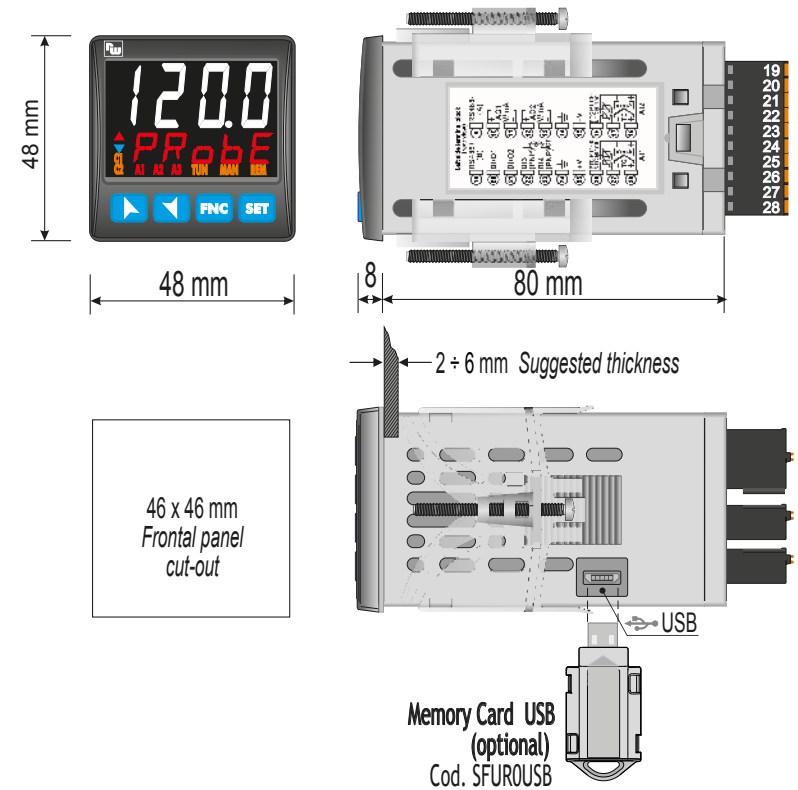

6

Electrical wirings

This controller has been designed and manufactured in conformity to Low Voltage Directive 2006/95/EC, 2014/35/EU (LVD) and EMC Directive 2004/108/EC, 2014/30/EU (EMC). For installation in industrial environments please observe following safety guidelines:

- Separate control line from power wires.
- Avoid proximity of remote control switches, electromagnetic contactors, powerful engines.
- Avoid proximity of power groups, especially those with phase control.
- It is strongly recommended to install adequate mains filter on power supply of the machine where the controller is installed, particularly if supplied 230Vac.

The controller is designed and conceived to be incorporated into other machines, therefore CE marking on the controller does not exempt the manufacturer of machines from safety and conformity requirements applying to the machine itself.

6.1 Wiring diagram

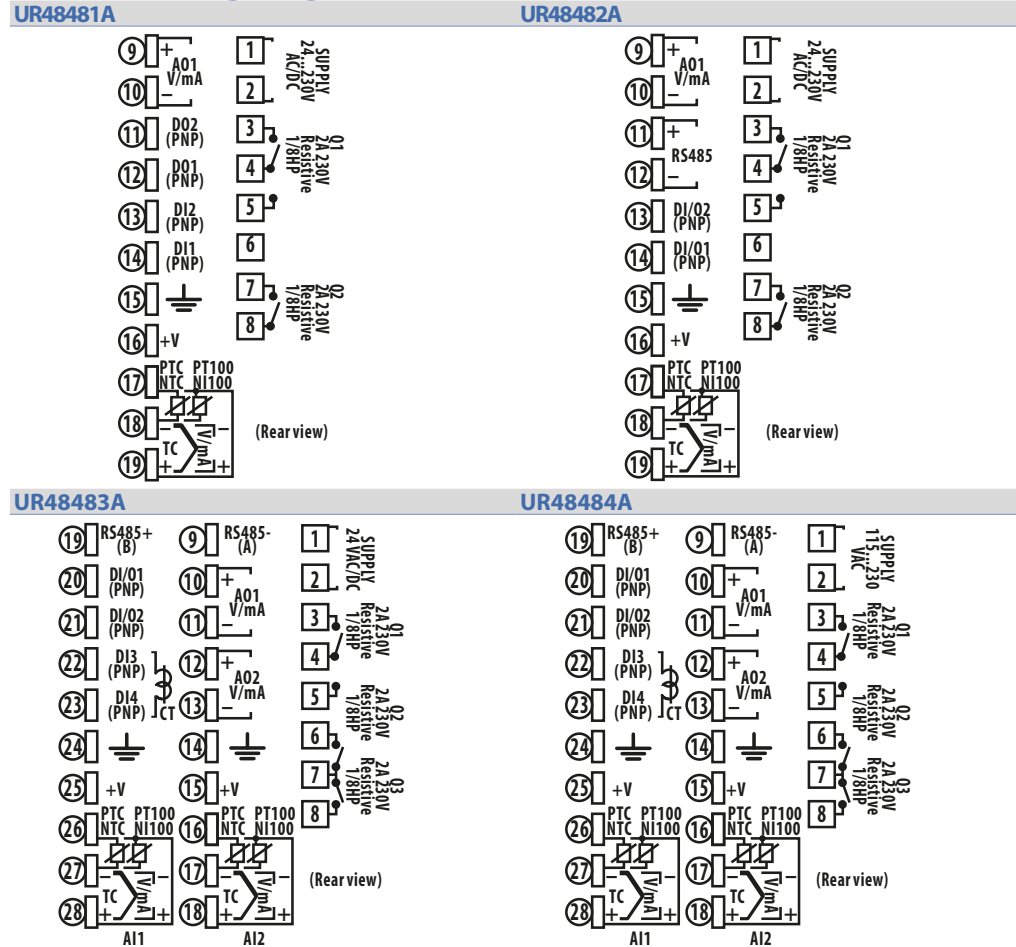

6.1.a Power Supply

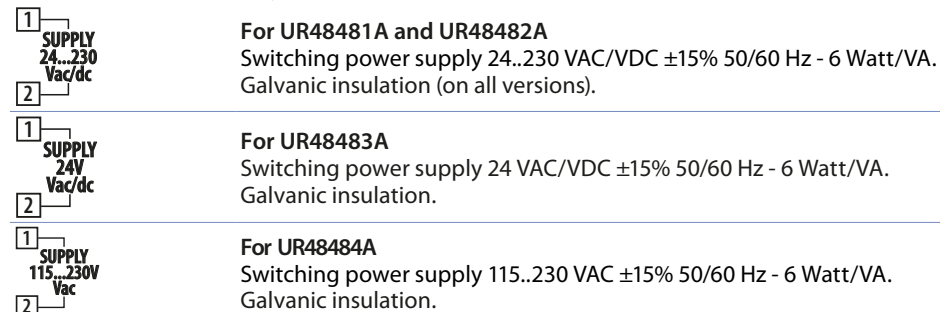

6.1.b Analogue Input AI1

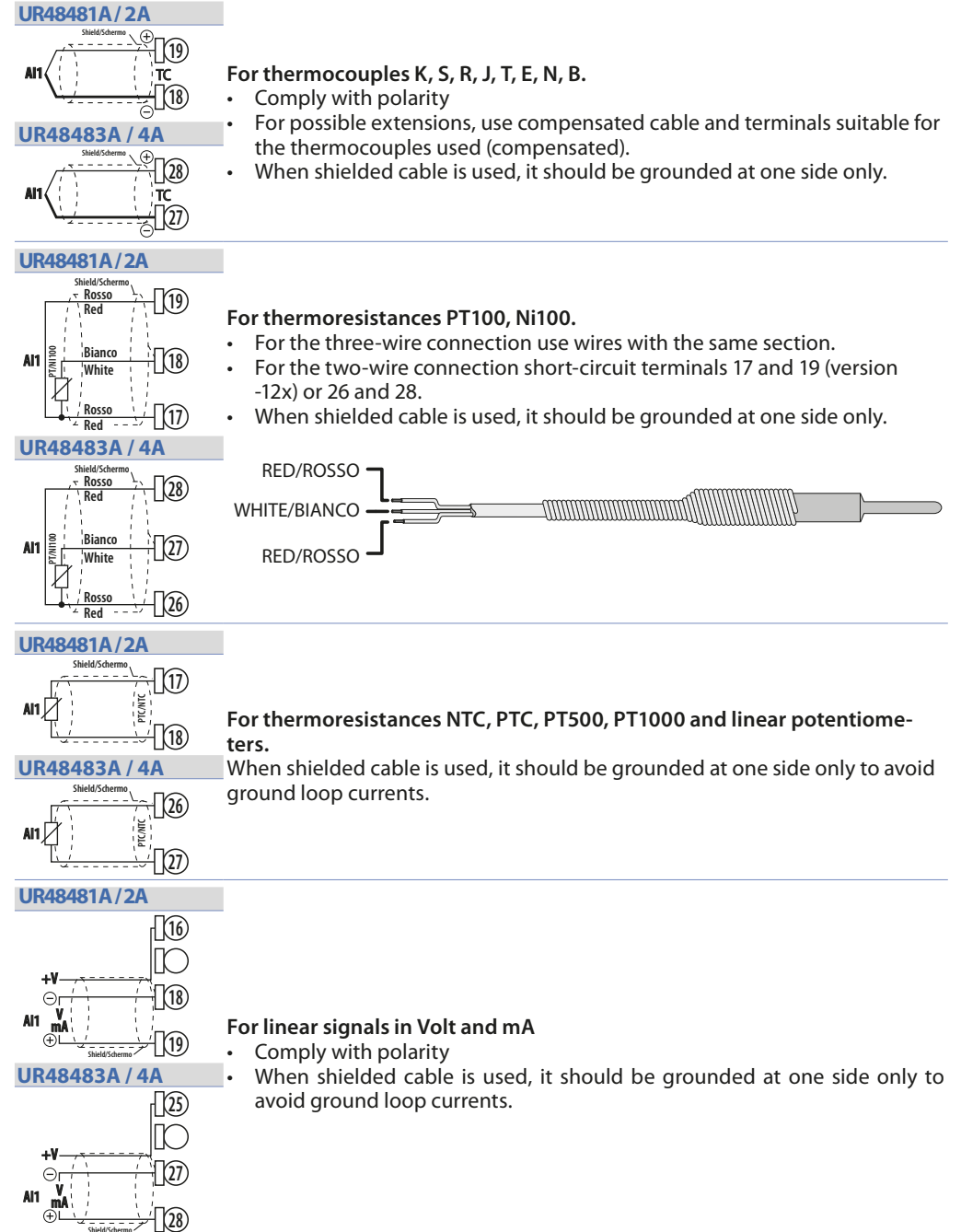

6.1.c Analogue Input AI2 (only UR48483A / 4A)

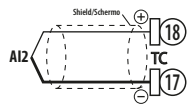

For thermocouples K, S, R, J, T, E, N, B.

- Comply with polarity
- For possible extensions, use compensated cable and terminals suitable for the thermocouples used (compensated).
- When shielded cable is used, it should be grounded at one side only.

For thermoresistances PT100, Ni100.

- For the three-wire connection use wires with the same section.
- For the two-wire connection short-circuit terminals 16 and 18.
- When shielded cable is used, it should be grounded at one side only.

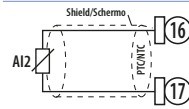
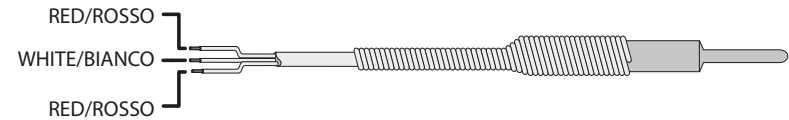
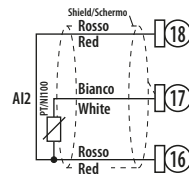

For thermoresistances NTC, PTC, PT500, PT1000 and linear potentiometers.
When shielded cable is used, it should be grounded at one side only to avoid ground loop currents.

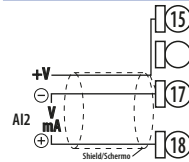

For linear signals in Volt and mA

- Comply with polarity
- When shielded cable is used, it should be grounded at one side only to avoid ground loop currents.

6.1.d CT input (only UR48483A / 4A)

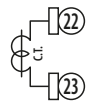

To enable CT input, modify parameter 287 $c \pm F$.

- Input for 50 mA amperometric transformer.
- Sampling time 100 ms.
- Configurable by parameters.

6.1.e Digital inputs UR4848..

1A 2A 3A/4A

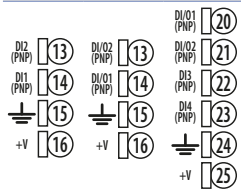

Digital inputs can be enabled by parameters.

Close pin "DIx" on pin "+V" to enable digital input.

It is possible to put in parallel the digital inputs of different devices joining together the ground pins (15).

6.1.f Serial inputs (only UR48482A / 3A / 4A)

UR48482A

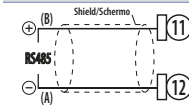

Modbus RS485 communication.
RTU Slave with galvanic insulation.

UR48483A / 4A

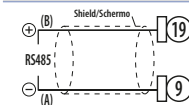

It is recommended to use the twisted and shielded cable for communications.

6.1.g Digital outputs UR4848..

1A 2A 3A / 4A

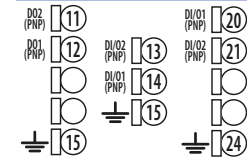

Digital output PNP (including SSR) for command or alarm.
Range 12 VDC/25 mA or 24 VDC/15mA selectable by parameter 282 $v.o.u.t.$

6.1.h Analogue output AO1

UR48481A / 2A

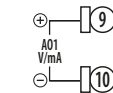

Linear output in mA or V (galvanically isolated) configurable as command, alarm or retransmission of process-setpoint.

UR48483A / 4A

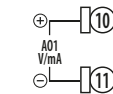

The selection mA or Volt for the linear output depends on the parameters configuration.

6.1.i Analogue output AO2 (only UR48483A / 4A)

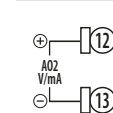

Linear output in mA or V (galvanically isolated) configurable as command, alarm or retransmission of process-setpoint.

The selection mA or Volt for the linear output depends on the parameters configuration.

6.1.j Relay output Q1

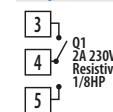

Capacity 2 A / 250 VAC for resistive loads.

See chart below.

6.1.k Relay output Q2 (only UR48481A / 2A)

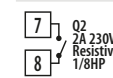

Capacity 2 A / 250 VAC for resistive loads.

See chart below.

6.1.l Relays output Q2 - Q3 (only UR48483A / 4A)

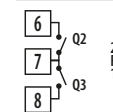

Capacity 2 A / 250 VAC for resistive loads.

See chart below.

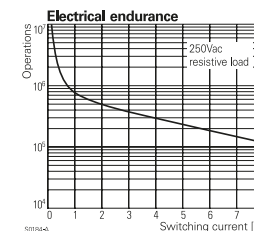

Electrical endurance Q1, Q2 e Q3:
2 A, 250 VAC, resistive loads, 10^5 operations.
20/2 A, 250 VAC, $\cos\phi = 0.3$, 10^5 operations.

7 Display and Key Functions

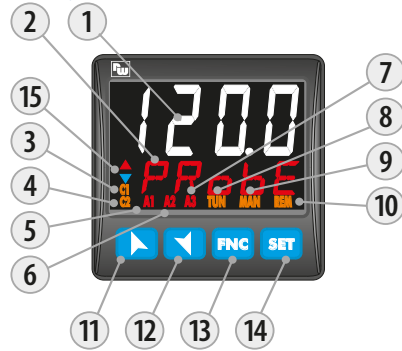

7.1 Numeric Indicators (Display)

1	1234	Normally displays the process. During the configuration phase, it displays the parameter being inserted.
2	Probe	Normally displays the setpoint. During the configuration phase, it displays the parameter value being inserted.

7.2 Meaning of Status Lights (Led)

3	C1	ON when the command output 1 is active. In case of motorized valve control it is ON during valve opening and flashes during valve closing.
4	C2	ON when the command output 2 is active. In case of motorized valve control it is ON during valve opening and flashes during valve closing.
5	A1	ON when alarm 1 is active.
6	A2	ON when alarm 2 is active.
7	A3	ON when alarm 3 is active.
8	TUN	ON when the controller is executing an auto-tuning cycle.
9	MAN	ON when "Manual" function is active.
10	REM	ON when the controller communicates through serial. Flashes when the remote setpoint is enabled.

7.3 Keys

11	▲	<ul style="list-style-type: none"> Increases the main setpoint. During configuration allows to scroll the parameters or the groups of parameters. Increases the setpoints.
12	▼	<ul style="list-style-type: none"> Decreases the main setpoint. During configuration allows to scroll the parameters or the groups of parameters. Decreases the setpoints.
13	SET	<ul style="list-style-type: none"> Allows to visualize command and alarm setpoints. During configuration allows to enter the parameter to be modified and confirms the variation.
14	FNC	<ul style="list-style-type: none"> Allows to enter the Tuning launch function, automatic/manual selection. During configuration works as exit key (ESCAPE).
	▲	ON during the rising phase of the pre-programmed cycle;
	▼	ON during the falling phase of the pre-programmed cycle;
	▲▼	Both ON during parameter modification, when this is not a default value.

8 Dual input mode

Each UR48483A/4A model is provided with two analogue inputs: it is possible to do mathematic operations between 2 measured process values, correlating obtained result to the command or alarm outputs, or to give a process value as remote setpoint. It is also possible to use the controller for 2 independent control loops.

8.1 Selection of process value related to the command output and to the alarms

When second analogue input is enabled (par.18 *SEn.2* other than *d.5Rb.*) it is possible to choose the process value to be related to command output, to alarms and to retransmission. Following options are available:

- *R.in.1*: Value read by input AI1;
 - *R.in.2*: Value read by input AI2;
 - *MEAN*: Mean between inputs AI1 and AI2;
 - *dIFF*: Difference between inputs: AI1-AI2;
 - *Ab.dIF*: Difference between inputs as absolute value: AI1-AI2;
 - Command 1 process must be selected on parameter 36 *c.Pr.1*
 - Command 2 process must be selected on parameter 55 *c.Pr.2*
 - The process related to the alarms must be selected on par. 124 *R.1.Pr.* for the alarm 1, on par. 142 *R.2.Pr.* for the alarm 2, on par. 160 *R.3.Pr.* for the alarm 3, and on par. 178 *R.4.Pr.* for the alarm 4, on par. 196 *R.5.Pr.* for the alarm 5 and on par. 214 *R.6.Pr.* for the alarm 6.
 - The value to be retransmitted must be selected on par. 299 *rEt.1* and/or on par. 308 *rEt.2*.
- It is possible to choose what to visualize on display 2 selecting par. 278 *u.i.d.2*.

8.2 Remote setpoint by analogue input

It is possible to enable remote setpoint function setting *EnAb.* or *En.tSt.* on par. 56 *rEn.5*.

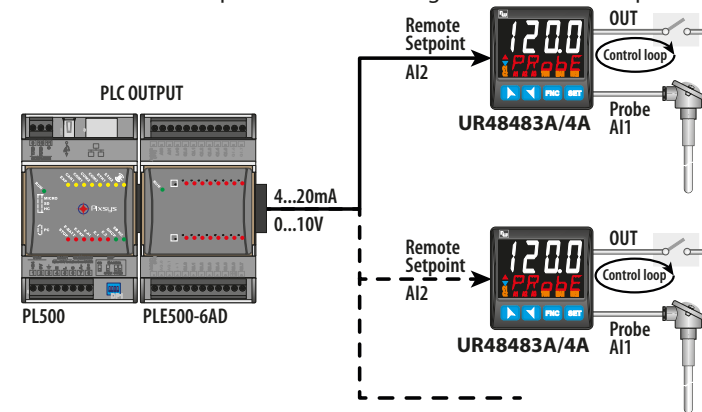

In this example the command setpoint is the value read on second analogue input AI2: on par. 55 *c.Pr.2* it is selected the input that determines the setpoint.

The Remote Setpoint function is active only selecting *R.in.1* or *R.in.2* on par. 55 *c.Pr.2*. Selecting *En.tSt.* on par. 56 *rEn.5* it is possible to switch from remote to local setpoint pressing **SET** for 1 second. The selection is stored even after the subsequent device restarts.

In remote setpoint mode the led **REM** is ON, it flashes when switching to local setpoint mode.

The decimal point setting parameter for the image input (or remote setpoint) is locked and modifies automatically when the command input decimal point is changed.

8.3 Remote setpoint by serial input



It is possible to enable remote setpoint function selecting $EnSEr$ or $EnSEt$ on par. 56 $rEnS$. The remote setpoint must be written on the word modbus 1249 for the command 1 and 1250 for the command 2 (with tenth of degree if the command process is a temperature sensor).

It is possible to switch from remote to local setpoint pressing **SET** for 1 second. In remote setpoint mode the led **REM** is ON (if there is serial communication), it flashes when switching to local setpoint mode. At restarting the controller keeps set in remote setpoint mode (the setpoint value is initialized to 0).

9 Controller Functions

9.1 Modification of main and alarm setpoint value

Setpoint value can be modified from keyboard as follows:

Press	Display	Do
1 	Value on display 2 changes.	Increases or decreases the main setpoint value.
2 SET	Visualizes the other setpoints on display 1. Display 2 shows the setpoint type.	
3 	Value on display 1 changes.	Increases or decreases the alarm setpoint value.

9.2 Automatic Tune

Automatic tuning procedure allows a precise regulation without delving into the PID regulation algorithm. Selecting Auto on par. 73 $tun.1$ (for the regulation loop 1), or on par. 98 $tun.2$ (for the regulation loop 2), the controller analyzes the process oscillations and optimizes the PID parameters.

Led **TUN** flashes.

If the PID parameters are not yet selected, at the device switch-on, it is automatically launched the manual Tuning procedure described into the next paragraph.

9.3 Manual Tune

Manual procedure allows the user greater flexibility to decide when to update PID algorithm parameters. During the manual tuning, the device generates a step to analyze the system inertia to be regulated and, according to the collected data, modifies PID parameters.

After selecting $MANu$ on par. 73 $tun.1$, or on par. 98 $tun.2$, the procedure can be activated in three ways:

- **Running Tuning by keyboard:**
Press **FNC** until display 2 shows $tunE$ with display 1 on dis. and then press **SET**: display 1 shows Enab. Led **TUN** switches ON and the procedure starts.
- **Running Tuning by digital input:**
Select $tunE$ on par. 231 $d.1.F$, (or on par. 239 $d.1.2.F$, par. 247 $d.1.3.F$, par. 255 $d.1.4.F$). At first activation of digital input (commutation on front panel) led **TUN** led switches on and at second activation switches off.
- **Running Tuning by serial input:**
Write 1 on word modbus 1216 (command 1) or 1217 (command 2): led **TUN** switches ON and the procedure starts. Write 0 to stop the tuning.

To avoid an overshoot, the threshold where the controller calculates new PID parameters is determined by this operation:

Tune threshold = Setpoint - "Set Deviation Tune" (par. 74 $S.d.t.1$ or par. 99 $S.d.t.2$)

Ex.: if the setpoint is 100.0°C and the Par.32 $S.d.t.1$ is 20.0°C the threshold to calculate PID parameters is $(100.0 - 20.0) = 80.0°C$.

For a greater precision on PID parameters calculation it is suggested to start the manual tuning procedure when the process deviates from the setpoint.

9.4 Tuning once

Set $once$ on parameter 73 $tun1$ or on parameter 98 $tun2$.

Autotuning procedure is executed only once at next UR4848xA restart. If the procedure doesn't work, will be executed at next restart.

9.5 Synchronized tuning

Set $Synch$ on parameter 73 $tun.1$ or on parameter 98 $tun.2$.

This procedure has been conceived to calculate correct PID values on multi-zone systems, where each temperature is influenced by the adjacent zones.

Writing on word modbus 1216 (for regulation loop 1) or 1217 (for regulation loop 2) the controller works as follows:

Word value	Action
0	Tune off
1	Command output OFF
2	Command output ON
3	Tune active
4	Tune completed: command output OFF (read only)
5	Tune not available: softstart function enabled (only reading)

Here below the functioning for regulation loop 1: the master switches-off or turns-on all zones (value 1 or 2 on word 1216) for a time long enough to create inertia on the system.

At this point the autotuning is launched (value 3 on word 1216). The controller executes the procedure for the calculation of the new PID values. When the procedure ends, the controller switches off the command output and selects the value 4 on word 1216. The master, who will always read the word 1216, will control the various zones and when all will have finished, will bring to 0 the value of word 1216: the various devices will regulate the temperature independently, with the new calculated values. N.B. The master must read the Index 0x400E at least every 10 seconds or the controller will automatically exit the autotuning procedure.

9.6 Digital input functions

The UR4848xA functions related to digital inputs, can be enabled by parameters 231 $d.1.F$, 239 $d.1.2.F$, 247 $d.1.3.F$ and 255 $d.1.4.F$.

- $2tSU$: Two threshold setpoint modification: with digital input active the UR4848xA regulates on **SET2**, otherwise reulates on **SET1**;
- $2tSU.1$: Modification of 2 setpoints by digital input with impulse command;
- $3tSU.1$: Modification of 3 setpoints by digital input with impulse command,
- $4tSU.1$: Modification of 4 setpoints by digital input with impulse command,
- $St.rSt$: Start / Stop of the controller by digital input with impulse command,
- run : The regulation is enabled only with digital input active,
- $Hold$: With digital input active the conversion is locked (visualization maintenance function);
- $tunE$: Enables/disables the Tuning if par. 73 $tun.1$ or par. 98 $tun.2$ is selected as $MANu$;
- $RU.MA.1$: If par. 48 $MAN.1$ or par. 67 $MAN.2$ is selected as $EnAb$ or $EnSto$, with impulse command on digital input, the UR4848xA switches the related regulation loop, from automatic to manual and vice versa.
- $RU.MA.c$: If par. 48 $MAN.1$ or par. 67 $MAN.2$ is selected as $EnAb$ or $EnSto$, the UR4848xA switches to manual the related regulation loop, with digital input active, otherwise the regulation is automatic.
- $Act.ty$: On the regulation loop selected for this function (par. 234 $d.1.1.r$ or 242 $d.1.2.r$ or 250 $d.1.3.r$ or 258 $d.1.4.r$), the UR4848xA execute a cooling type regulation with digital input active, otherwise the regulation is of heating type;
- $R.i.0$: Zero tare function: brings the related analogue input to 0. The analogue input is selected on par. 233 $d.1.1.P$ or 241 $d.1.2.P$ or 249 $d.1.3.P$ or 257 $d.1.4.P$.
- $PRESt$: Allows the reset of the output if manual reset is active for the alarms and for the command outputs selected on par. 234 $d.1.1.r$ or 242 $d.1.2.r$ or 250 $d.1.3.r$ or 258 $d.1.4.r$;
- $t.run$: If timer 1 is enabled (par. 328 $tPr.1$ different from $d.5Ab$), with digital input active, the timer is

switched to RUN, otherwise is kept in STOP;

- *t.1S.E.*: If timer 1 is enabled (par. 328 *t.1r.1* different from *d.5AB*), acting on the digital input, the status of the timer switches from STOP to RUN e vice versa;
- *t.1S.E.A.*: If il timer 1 is enabled (par. 328 *t.1r.1* different from *d.5AB*), acting on the digital input, the timer is switched to RUN;
- *t.1E.nd*: If il timer 1 is enabled (par. 328 *t.1r.1* different from *d.5AB*), acting on the digital input, the timer is switched to STOP;
- *t.2.r.un*: If timer 2 is enabled (par. 331 *t.2r.2* different from *d.5AB*), with digital input active, the timer is switched to RUN, otherwise is kept in STOP;
- *t.2S.E.*: If timer 2 is enabled (par. 331 *t.2r.2* different from *d.5AB*), acting on the digital input, the status of the timer switches from STOP to RUN e vice versa;
- *t.2S.E.A.*: If timer 2 is enabled (par. 331 *t.2r.2* different from *d.5AB*), acting on the digital input, the timer is switched to RUN;
- *t.2E.nd*: If timer 2 is enabled (par. 331 *t.2r.2* different from *d.5AB*), acting on the digital input, the timer is switched to STOP;
- *Lo.c.F.L.*: With digital input active, the access to setpoint configuration/modification is locked;
- *r.E.N.S.E.*: If on par. 56 *r.E.N.S.* it is selected *EnAB*. or *En.SEr*), with digital input active the remote setpoint is enabled, otherwise the setpoint is local. On par. 234 *d.1.1.r.* or 242 *d.1.2.r.* or 250 *d.1.3.r.* or 258 *d.1.4.r.* it is necessary to select the reference regulation loop.

9.7 Automatic / Manual regulation for % output control

This function allows to switch from automatic functioning to manual command of the output percentage.

With par. 48 *R.N.A.1* (for regulation loop 1) or par. 67 *R.N.A.2* (for regulation loop 2) it is possible to select two modes.

- 1 First selection** (*EnAB*) allows to enable with **FUNC** the writing *P.---* on display 1, while on display 2 is showed *Auto*. Press **SET** to visualize *MAN*; it's now possible, during the process visualization, modify through the keys **▲** and **▼** the output percentage. To back to automatic, with the same procedure, select *Auto*. on display 2: immediately led **MAN** switches off and functioning backs to automatic.
- 2 Second selection** (*En.SEr*) enables the same functioning but with two important variants:
 - If there is a temporary power failure or after switch-off, the manual functioning as well as the previous output percentage value will be maintained at restarting.
 - If the sensor breaks during automatic functioning, the controller switches to manual mode while maintaining the output percentage command unchanged as generated by the PID immediately before breakage.
Ex: on an extruder the command in percentage of the resistance (load) is maintained also in case of input sensor failure.

9.8 Heater Break Alarm on CT (current transformer - only on UR48483A/4A)

This function allows to measure load current to manage an alarm during a malfunctioning with power in short circuit, always open or partial break of the charge. To enable this function set *SD H2* or *EO H2* on par. 287 *ct F*. and the value of the connected transformer, on par. 288 *ct u.*

- Select on par. 289 *H.b.A.r.* the regulation loop referred to the current measure and the Heater Break Alarm intervention.
- Select on par. 290 *H.b.A.l.* the Heater Break Alarm intervention threshold in Ampere.
- Select on par. 291 *o.c.u.t.* the intervention threshold in Ampere to control the overcurrent.
- Select on par. 292 *H.b.A.d.* the delay time in seconds for the Heater Break Alarm intervention.
- It is possible to associate an alarm, selecting *H.b.A.* on par. 123 *AL.1F.* on par. 141 *AL.2F.* or par. 159 *AL.3F.* or par. 177 *AL.4F.* or par. 195 *AL.5F.* or par. 213 *AL.6F.*

It is possible to visualize on display 2 the average current, selecting *AMPER.* on par. 278 *u.1.d.2*. Selecting 0 on par. 290 *H.b.A.l.* it is possible to visualize the current consumption without generating an Heater Break Alarm.

9.9 Dual Action (Heating-Cooling)

UR4848xA is suitable also for systems requiring a combined heating-cooling action.

The command output has to be configured as PID for Heating (Par. 38 *Ac.t.1* or Par. 57 *Ac.t.2 = HEAT* and *P.b. 1* or *P.b. 2* greater than 0), and one of the alarms (*AL.1F.*, *AL.2F.*, *AL.3F.*, *AL.4F.*, *AL.5F.* or *AL.6F.*) has to be configured as *cool*.

The command output must be connected to the actuator responsible for heating, while the alarm will control cooling action.

Parameters to be configured for the heating PID are:

- *Ac.t.1* or *Ac.t.2 = HEAT* Command output action type (Heating);
- *P.b. 1* or *P.b. 2*: Heating proportional band;
- *i.t. 1* or *i.t. 2*: Integral time of heating and cooling;
- *d.t. 1* or *d.t. 2*: Derivative time of heating and cooling;
- *c.t. 1* or *c.t. 2*: Heating time cycle.

Parameters to be configured for the cooling PID related to regulation loop 1 and alarm 1 are:

- *AL.1F. = cool*. Alarm 1 selection (Cooling);
- *P.b.1.1*: Proportional band multiplier;
- *o.d.b.1*: Overlapping / Dead band;
- *c.c.t.1*: Cooling time cycle.

Par. *P.b.1.1* (that ranges from 1.00 to 5.00) determines the proportional band of cooling action basing on the formula:

$$\text{Proportional band for cooling action} = P.b. \times P.b.1.1$$

This gives a proportional band for cooling which will be the same as heating band if *P.b.1.1 = 1.00*, or 5 times greater if *P.b.1.1 = 5.00*.

Integral and derivative time are the same for both actions.

Par. *o.d.b.1* determines the percentage overlapping between the two actions. For systems in which the heating output and cooling output must never be simultaneously active a Dead Band (*o.d.b.1 ≤ 0*), must be configured, vice versa you can configure an overlapping (*o.d.b.1 > 0*).

The following figure shows an example of dual action PID (heating-cooling) with *i.t. 1 = 0* e *d.t. 1 = 0*.

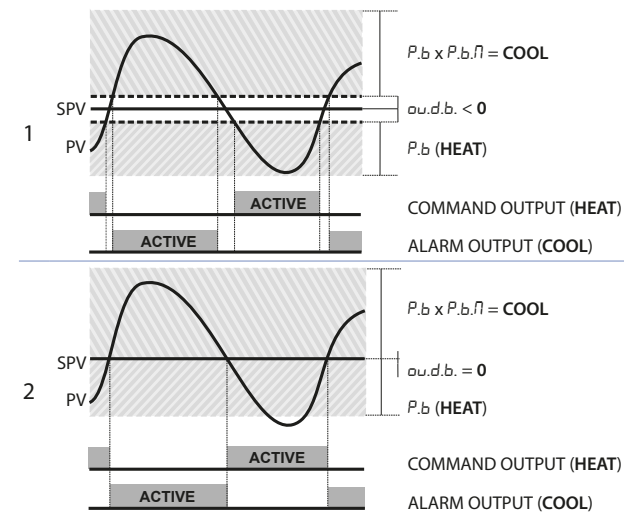

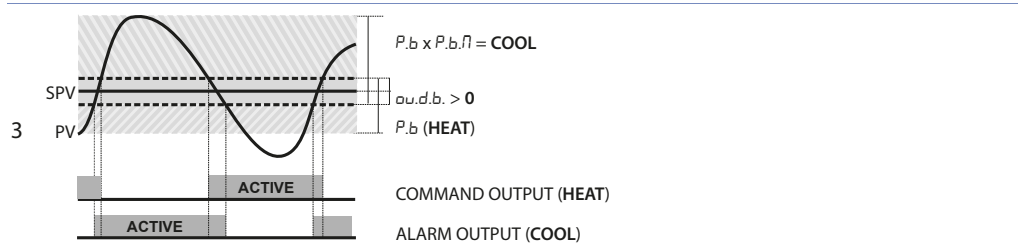

Parameter $c.c.t.l$ has the same meaning of cycle time for heating action $c.t.l$.
 Parameter $co.F.l$ (Cooling Fluid) pre-selects the proportional band multiplier $P.b.n.l$ and the cooling PID cycle time $c.c.t.l$ according to cooling fluid type:

$co.F.l$	Cooling fluid type	$P.b.n.l$	$c.c.t.l$
$R.ir$	Air	1.00	10
$o.il$	Oil	1.25	4
$H2O$	Water	2.50	2

Once parameter $co.F.l$ has been selected, the parameters $P.b.n.l$, $o.d.b.l$ and $c.c.t.l$ can be however modified.

9.10 LATCH ON Function

For use with input $P.o.t.$ and with linear input (0..10 V, 0..40 mV, 0/4..20 mA) it is possible to associate start value of the scale (par. 4 $l.l.i.l$ or par. 21 $l.l.i.2$) to the minimum position of the sensor and value of the scale end (par. 5 $u.l.i.l$ or par. 22 $u.l.i.2$) to the maximum position of the sensor (par. 10 $l.t.c.l$ or par. 27 $l.t.c.2$ configured as $5.t.e.n.d.r.$).

It is also possible to fix the point in which the controller will display 0 (however keeping the scale range between $l.l.i.l$ / $l.l.i.2$ and $u.l.i.l$ / $u.l.i.2$) using the "virtual zero" option by selecting $u.d.5.t.o.$ or $u.d.5.t.o.n.$ on par. 10 $l.t.c.l$ or 27 $l.t.c.2$. Selecting $u.d.5.t.o.n.$ the virtual zero must be reset at each switching on; selecting $u.d.5.t.o.$ the virtual zero will remain fixed once calibrated. To use the LATCH ON function, configure the par. $l.t.c.l$ or 27 $l.t.c.2$.

Then refer to the following table for the calibration procedure:

Press	Display	Do
1 FNC	Exit parameters configuration. Display 2 visualizes writing $l.R.t.c.$	Place the sensor on minimum operating value (corresponding to $l.l.i.l$ / $l.l.i.2$)
2 ✓	Store value on minimum. Display shows $l.o.u.$	Place sensor on maximum operating value (corresponding to $u.l.i.l$ / $u.l.i.2$).
3 ▲	Store value on max. Display shows $H.i.u.h.$	To exit standard proceeding press SET . For "virtual zero" setting, place the sensor to zero point.
4 FNC	Set virtual zero. Display shows $z.E.r.o.$. If "Virtual zero at start" is selected, point 4 must be repeated at each starting.	To exit procedure press SET .

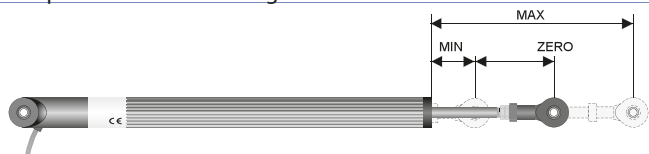

¹The tuning procedure starts by exiting the configuration after changing the parameter.

9.11 Soft-Start Function

UR4848xA is provided with two types of softstart selectable on parameter 264 $55.t.t.$ ("Softstart Type").

- 1 First selection ($G.r.A.d.$) enables gradient softstart. At starting the controller reaches setpoint basing on the rising gradient set on parameter 266 $55.G.r.$ ("Softstart Gradient") in Unit/hour (ex. °C/h). If parameter 269 $55.t.i.$ ("Softstart Time") is different to 0, at starting when the time selected on par. 269 is elapsed, the controller stops to follow the gradient and reaches setpoint with the maximum power.
- 2 Second selection ($P.E.r.c.$) enables output percental softstart. On par. 268 $55.t.h.$ it is possible to set the threshold under which starts the softstart ("Softstart Threshold"). On par. 267 $55.P.E.$ ("Softstart Percentage") an output percentage is selectable (from 0 to 100), which controller keeps until the process exceeds the threshold set on par. 268 or until the time in minutes set on par. 269 $55.t.i.$ ("Softstart Time" word 2084).

If the Sof-Start function is active the automatic/manual Tuning function cannot be activated.

9.12 Pre-Programmed cycle

Pre-programmed cycle function activates by setting $ENR.b.$ on parameter 263 $P.r.c.y.$.

Controller reaches setpoint 1 basing on the gradient set on parameter 266 $55.G.r.$, then it reaches max. power up to setpoint 2. When the process reaches max. power, this setpoint is maintained for the time set on parameter 270 $n.R.t.i.$.

At expiry, process will reach ambient temperature according to gradient entered on parameter 271 $F.R.G.r.$, then command output will be disabled and display will visualize $5.t.o.P.$

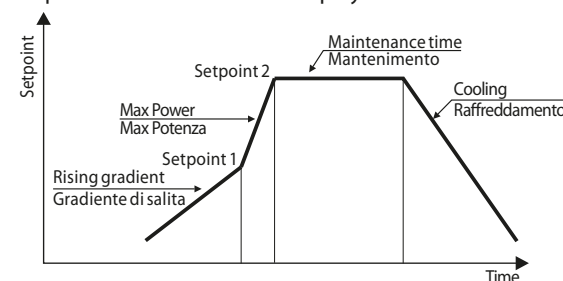

Cycle starts at each activation of the controller, or via digital input if it is enabled for this type of functioning (parameters 231, 239, 247, 255 set as $5.t.i.5.t.$ or $P.u.t.$).

9.13 Retransmission function on analogue output

If not used as command, the analogue output can be used to retransmit process/ setpoint/ current read by the C.T. input/ output percentage.

Select on parameter 298 $r.t.n.l$ ("Retransmission 1") or on parameter 308 $r.t.n.2$ ("Retransmission 2") the value to be retransmitted and on parameter 299 $r.l.t.t.$ ("Retransmission 1 Type") or on parameter 309 $r.l.t.t.2$ ("Retransmission 2 Type") the output type.

It is possible also to select on parameters 300 $r.l.l.l.$ and 301 $r.l.u.l.$ or 310 $r.l.l.l.$ and 311 $r.l.u.l.$ the input value rescale limites.

10 Serial communication

UR48482A/ 3A/ 4A is equipped with RS485 and can receive/broadcast data via serial communication using MODBUS RTU protocol. The device can only be configured as a Slave. This function enables the control of multiple controllers connected to a supervisory system / SCADA. Each controller responds to a Master query only if the query contains the same address as parameter 318 *SLAd*. ("Slave Address").

The addresses permitted range from 1 to 254 and there must not be controllers with the same address on the same line.

Address 255 can be used by the Master to communicate with all the connected equipment (broadcast mode), while with 0 all the devices receive the command, but no response is expected.

The baud rate is selected on parameter 319 *bd.r.t.* ("Baud Rate").

UR4848xA can introduce a delay (in milliseconds) of the response to the master request. This delay must be set on parameter 321 *SE.dE.* ("Serial Delay").

Each parameter modification is saved by the controller in the EEPROM memory (100000 writing cycles), while the setpoints are saved with a delay of 10 seconds after the last modification.

Changes made to words that are different from those reported in the following table can lead to malfunction.

Modbus RTU protocol features

	Selectable on parameter 319 <i>bd.r.t.</i>	
Baud-rate	1200bit/s	28800bit/s
	2400bit/s	38400bit/s
	4800bit/s	57600bit/s
	9600bit/s	115200bit/s
	19200bit/s	
	Selectable on parameter 320 <i>S.P.P.</i>	
Format	8N1	8N2
	8E1	8E2
	8O1	8O2
Supported functions	WORD READING (max 50 word) (0x03, 0x04)	
	SINGLE WORD WRITING (0x06)	
	MULTIPLE WORDS WRITING (max 50 word) (0x10)	

Here below a list of all available addresses and supported functions:

RO = Read Only R/W = Read/Write WO = Write Only

Modbus address	Description	Read Write	Reset value
0	Device type	RO	47x
1	Software version	RO	Flash
2	Boot version	RO	Flash
3	Slave Address	RO	Eepr/dip
6	Baud rate	RO	Eepr/dip
50	Slave address automatic learning	WO	-
51	System code comparison for slave address automatic learning	WO	-
500	Loading default values (write 9999)	RW	0
501	Restart UR4848xA (write 9999)	RW	0
502	Setpoint storing delay time	RW	10
503	Parameters storing delay time	RW	1
1000	AI1 value (degrees with tenth)	RO	-
1001	AI2 value (degrees with tenth)	RO	-
1002	Average between AI1 and AI2 [(AI1 + AI2) / 2] (degrees with tenth)	RO	0
1003	Difference between AI1 and AI2 (AI1 - AI2) (degrees with tenth)	RO	0
1004	Module of the difference between AI1 and AI2 (AI1 - AI2) (degrees with tenth)	RO	0

Modbus address	Description	Read Write	Reset value
1005	Sum of AI1 and AI2 (AI1 + AI2) (degrees with tenth)	RO	0
1006	Real setpoint (gradient) of the regulation loop 1	RO	0
1007	Real setpoint (gradient) of the regulation loop 2	RO	0
1008	Alarms status (0=absent, 1=present) Bit0 = Alarm 1 Bit3 = Alarm 4 Bit1 = Alarm 2 Bit4 = Alarm 5 Bit2 = Alarm 3 Bit5 = Alarm 6	RO	0
	Error flags 1 Bit0 = AI1 process error (sensor 1) Bit1 = AI2 process error (sensor 2) Bit2 = Cold junction error Bit3 = Safety error Bit4 = Generic error Bit5 = Hardware error Bit6 = Error H.B.A. (partial ropture of the load) Bit7 = Error H.B.A. (SSR in short circuit) Bit8 = Overcurrent error Bit9 = Parameters out of range error Bit10= CPU eeprom writing error Bit11= Rfid eeprom writing error Bit12= CPU eeprom reading error Bit13= Rfid eeprom reading error Bit14= Eeprom calibrations bench corrupted Bit15= Eeprom constants bench corrupted		
1009	Error flags 2 Bit0 = Missing calibrations error Bit1 = Eeprom CPU bench parameters corrupted Bit2 = Eeprom CPU setpoint bench corrupted Bit3 = Rfid memory not formatted Bit4 = Error AI2 disabled	RO	0
	Digital inputs status (0=not active, 1=active) Bit0 = Digital inp. 1 Bit2 = Digital inp. 3 Bit1 = Digital inp. 2 Bit3 = Digital inp. 4	RO	0
1010	Outputs status (0=off, 1=on) Bit 0 = Q1 Bit 3 = DO1 Bit 1 = Q2 Bit 4 = DO2 Bit 2 = Q3	RO	0
	Stato led (0=OFF, 1=ON) Bit 0 = Led UP arrow Bit 6 = Led TUN Bit 1 = Led C1 Bit 7 = Led point time 2 Bit 2 = Led C2 Bit 8 = Led MAN Bit 3 = Led A1 Bit 9 = Led REM Bit 4 = Led A2 Bit 10 = Led DOWN arrow Bit 5 = Led A3 Bit 11 = Led point time 1	RO	0
1011	Key status (0=released, 1=pressed) Bit 0 = Key UP arrow Bit 2 = Key FNC Bit 1 = Key DOWN arrow Bit 3 = Key SET	RO	0
	1012		
1013			
1014			
1015	Cold junction temperature (degrees with tenth)	RO	-
1016	Current CT istantaneous (Ampere with tenth)	RO	0
1017	Current CT average (Ampere with tenth)	RO	0
1018	Current CT ON (Ampere with tenth)	RO	0
1019	Current CT OFF (Ampere with tenth)	RO	0
1100	AI1 value with decimal point selection	RO	-

Modbus address	Description	Read Write	Reset value
1101	AI2 value with decimal point selection	RO	-
1102	Average between AI1 and AI2 [(AI1 + AI2) / 2] with decimal point selection	RO	0
1103	Difference between AI1 and AI2 (AI1 - AI2) with decimal point selection	RO	0
1104	Module of the difference between AI1 and AI2 (AI1 - AI2) with decimal point selection	RO	0
1105	Sum of AI1 and AI2 (AI1 + AI2) with decimal point selection	RO	0
1106	Real setpoint (gradient) of the regulation loop 1 with decimal point selection	RO	0
1107	Real setpoint (gradient) of the regulation loop 2 with decimal point selection	RO	0
1200	Setpoint 1 of regulation loop 1 (degrees with tenth)	R/W	EEPROM
1201	Setpoint 2 of regulation loop 1 (degrees with tenth)	R/W	EEPROM
1202	Setpoint 3 of regulation loop 1 (degrees with tenth)	R/W	EEPROM
1203	Setpoint 4 of regulation loop 1 (degrees with tenth)	R/W	EEPROM
1204	Setpoint 1 of regulation loop 2 (degrees with tenth)	R/W	EEPROM
1205	Setpoint 2 of regulation loop 2 (degrees with tenth)	R/W	EEPROM
1206	Setpoint 3 of regulation loop 2 (degrees with tenth)	R/W	EEPROM
1207	Setpoint 4 of regulation loop 2 (degrees with tenth)	R/W	EEPROM
1208	Alarm 1 setpoint (degrees with tenth)	R/W	EEPROM
1209	Alarm 2 setpoint (degrees with tenth)	R/W	EEPROM
1210	Alarm 3 setpoint (degrees with tenth)	R/W	EEPROM
1211	Alarm 4 setpoint (degrees with tenth)	R/W	EEPROM
1212	Alarm 5 setpoint (degrees with tenth)	R/W	EEPROM
1213	Alarm 6 setpoint (degrees with tenth)	R/W	EEPROM
1214	Start/Stop 0=controller in STOP 1=controller in START	R/W	0
1215	Hold conversion ON/OFF 0=Hold conversion OFF 1=Hold conversion ON	R/W	0
1216	Tune management for regulation loop 1 With automatic Tune (par. 73 $t_{un.1} = R_{u}t_{o}$): 0=autotuning function OFF 1=autotuning ON With manual Tune (par. 73 $t_{un.1} = \overline{P}R_{nu}$ or $\overline{D}ncE$): 0=autotuning function OFF 1=autotuning ON With synchronized Tune (par. 73 $t_{un.1} = S_{yn}cH$): 0=autotuning function OFF 1=command output OFF (forces the cooling) 2=command output ON (forces the heating) 3=autotuning ON 4=autotuning ended	RO R/W R/W	0 0 0

Modbus address	Description	Read Write	Reset value
1217	Tune management for regulation loop 2 With automatic Tune (par. 98 $t_{un.2} = R_{u}t_{o}$): 0=autotuning function OFF 1=autotuning ON With manual Tune (par. 98 $t_{un.2} = \overline{P}R_{nu}$ or $\overline{D}ncE$): 0=autotuning function OFF 1=autotuning ON With synchronized Tune (par. 98 $t_{un.2} = S_{yn}cH$): 0=autotuning function OFF 1=command output OFF (forces the cooling) 2=command output ON (forces the heating) 3=autotuning ON 4=autotuning ended	RO R/W R/W	0 0 0
1218	Automatic/manual selection for regulation loop 1 0=automatic; 1=manual	R/W	0
1219	Automatic/manual selection for regulation loop 2 0=automatic; 1=manual	R/W	0
1220	Command output percentage for regulation loop 1 (0-10000) Heating output percentage with regulation 1 in double loop (0-10000)	R/W	0
1221	Command output percentage for regulation loop 1 (0-1000) Heating output percentage with regulation 1 in double loop (0-1000)	R/W	0
1222	Command output percentage for regulation loop 1 (0-100) Heating output percentage with regulation 1 in double loop (0-100)	R/W	0
1223	Cooling output percentage with regulation 1 in double loop (0-10000)	RO	0
1224	Cooling output percentage with regulation 1 in double loop (0-1000)	RO	0
1225	Cooling output percentage with regulation 1 in double loop (0-100)	RO	0
1226	Command output percentage for regulation loop 2 (0-10000) Heating output percentage with regulation 2 in double loop (0-10000)	R/W	0
1227	Command output percentage for regulation loop 2 (0-1000) Heating output percentage with regulation 2 in double loop (0-1000)	R/W	0
1228	Command output percentage for regulation loop 2 (0-100) Heating output percentage with regulation 2 in double loop (0-100)	R/W	0
1229	Cooling output percentage with regulation 2 in double loop (0-10000)	RO	0
1230	Cooling output percentage with regulation 2 in double loop (0-1000)	RO	0
1231	Cooling output percentage with regulation 2 in double loop (0-100)	RO	0
1232	Command output manual reset for regulation loop 1: write 0 to reset the command output. In reading 0=reset not allowed, 1=reset allowed Alarms manual reset: write 0 to reset all alarms. In reading 0=reset not allowed, 1=reset allowed	R/W	0
1233	Bit0 = Alarm 1 Bit3 = Alarm 4 Bit1 = Alarm 2 Bit4 = Alarm 5 Bit2 = Alarm 3 Bit5 = Alarm 6	R/W	0
1234	Command output manual reset for regulation loop 2: write 0 to reset the command output. In reading 0=reset not allowed, 1=reset allowed	R/W	0
1235	Alarm 1 remote stauts (0=absent, 1=present)	R/W	0
1236	Alarm 2 remote stauts (0=absent, 1=present)	R/W	0
1237	Alarm 3 remote stauts (0=absent, 1=present)	R/W	0
1238	Alarm 4 remote stauts (0=absent, 1=present)	R/W	0
1239	Alarm 5 remote stauts (0=absent, 1=present)	R/W	0
1240	Alarm 6 remote stauts (0=absent, 1=present)	R/W	0
1241	Value AO1 by serial (Par. 298 $r_{t.1} = \overline{P}d.bu5$)	R/W	0

Modbus address	Description	Read Write	Reset value
1242	Value AO2 by serial (Par. 308 $r_t \cdot \pi_2 = \pi_d \cdot b_{05}$)	R/W	0
1243	Tara di zero AI1 (1=tare; 2=reset tare)	R/W	0
1244	Tare of zero AI2 (1=tare; 2=reset tare)	R/W	0
1245	Tare of zero average between AI1 and AI2 $[(AI1 + AI2) / 2]$ (1=tare; 2=reset tare)	R/W	0
1246	Tare of zero difference between AI1 and AI2 $(AI1 - AI2)$ (1=tare; 2=reset tare)	R/W	0
1247	Tare of zero module of the difference between AI1 and AI2 $(AI1 - AI2)$ (1=tare; 2=reset tare)	R/W	0
1248	Tare of zero sum of AI1 and AI2 $(AI1 + AI2)$ (1=tare; 2=reset tare)	R/W	0
1249	Value of remote setpoint by command 1 serial	R/W	0
1250	Value of remote setpoint by command 2 serial	R/W	0
1300	Setpoint 1 of regulation loop 1, with decimal point selection	R/W	EEPROM
1301	Setpoint 2 of regulation loop 1, with decimal point selection	R/W	EEPROM
1302	Setpoint 3 of regulation loop 1, with decimal point selection	R/W	EEPROM
1303	Setpoint 4 of regulation loop 1, with decimal point selection	R/W	EEPROM
1304	Setpoint 1 of regulation loop 2, with decimal point selection	R/W	EEPROM
1305	Setpoint 2 of regulation loop 2, with decimal point selection	R/W	EEPROM
1306	Setpoint 3 of regulation loop 2, with decimal point selection	R/W	EEPROM
1307	Setpoint 4 of regulation loop 2, with decimal point selection	R/W	EEPROM
1308	Alarm 1 setpoint, with decimal point selection	R/W	EEPROM
1309	Alarm 2 setpoint, with decimal point selection	R/W	EEPROM
1310	Alarm 3 setpoint, with decimal point selection	R/W	EEPROM
1311	Alarm 4 setpoint, with decimal point selection	R/W	EEPROM
1312	Alarm 5 setpoint, with decimal point selection	R/W	EEPROM
1313	Alarm 6 setpoint, with decimal point selection	R/W	EEPROM
2001	Parameter 1	R/W	EEPROM
2002	Parameter 2	R/W	EEPROM
...	Parameter ...	R/W	EEPROM
2366	Parameter 366	R/W	EEPROM

11 Reading and configuration through NFC



Scan the QR-Code to download the App on Google Play Store®

The controller UR4848xA is supported by the App Wachendorff EMG: using an ANDROID smartphone with NFC connection it is possible to program the device without using a dedicated equipment. The App allows to read, set and backup all parameters which are stored into the internal memory of Wachendorff devices.

Procedure:

- Identify the position of the NFC antenna on the smartphone (usually central, behind the back cover) or to one of the sides in case of metal chassis. The UR4848xA's antenna is placed on the frontal panel, under the function keys.
- Make sure that the NFC sensor of the phone is enabled or that there are no metal materials between the phone and the device (ex. aluminium cover or with magnetic stand)
- It is useful to enable the system sounds on the smartphone, as the notification sound confirms that the device has correctly been detected.

The App interface is provided with four tabs: SCAN, DATA, WRITE, EXTRA.

Select the first tab "SCAN" to read data stored into the internal memory of the device; place the smartphone in contact with the controller frontal panel, making sure that the phone's antenna matched with that of the controller.

Once detected the device, the App emits a notification sounds and proceeds with the model identification and the reading of the parameters.

The graphic interface shows the advancement and switches to the second tab "DATA". It is now possible to move the smartphone away from the controller to make the required modifications more easily. The device parameters are divided into collapsible groups and are displayed with name, current value and reference index to the manual.

Click on a row to open the setting screen of the related parameter with the detailed view of available options (in case of multiple choice parameters) or of the minimum/maximum/decimals limits (for numeric parameters), included the text description (as per section n. 11 of the user manual). Once selected the chosen value, the related row will be updated and underlined into the tab "DATA" (hold down the line to cancel modifications).

To download the new configuration on your device, select the third tab "WRITE", place again the smartphone in contact with the controller and wait for the notification.

The UR4848xA will show a restart request, necessary to update the configuration with the new written modifications; if it does not restart, the UR4848xA will continue to work with the previous configuration. In addition to the classic operation of parameters reading->modification->writing, Wachendorff EMG is provided with additional functions which can be accessed by the tab "EXTRA", as save parameters / e-mail loaded values/ restore default values.

12 Access configuration

Press	Display	Do
1 FNC for 3 sec.	Display 1 shows <i>PPRS</i> , while display 2 shows <i>0000</i> with the 1st digit flashing.	
2 ▲ ▼	Modify flashing digit and move to next digit with SET .	Enter password <i>1234</i> .
3 FNC to confirm	Display 1 shows the first parameters group, display 2 shows the description.	
4 ▲ or ▼	Scroll parameters groups.	
5 SET to confirm	Display 1 shows the first parameter of the group and display 2 shows its value.	Press FNC to exit configuration.
6 ▲ or ▼	Scroll parameters.	
7 SET to confirm	Allows parameter modification (display 2 flashes)	
8 ▲ or ▼	Increases or decreases visualized value	Introduce new data
9 SET	Confirms and stores the new value. If the value is different from default values, the arrow keys light on.	
10 FNC	Backs to parameter groups selection (see point 3).	Press again FNC to exit configuration

12.1 Loading default values

This procedure allows to restore factory settings of the device.

Press	Display	Do
1 FNC for 3 sec	Display 1 shows <i>PPRS</i> , while display 2 shows <i>0000</i> with the 1st digit flashing.	
2 ▲ or ▼	Modify the flashing digit and move to the next one pressing SET .	Enter password <i>9999</i> .
3 FNC to confirm	The device loads default settings and restarts.	

12.2 Parameters list functioning

The controller UR4848xA integrates many features that make the configuration parameters list very long. To make it more functional, the parameters list is dynamics and it changes as the user enables / disables the functions. Practically, using a specific function that occupies a given input (or output), the parameters referred to other functions of that resource are hidden to the user making the parameters list more concise.

To simplify the reading/interpretation of the parameters, pressing **SET** it is possible to visualize a brief description of the selected parameter.

Finally, keeping pressed **FNC**, it is possible to move from the mnemonic visualization of the parameter to the numeric one, and vice versa. Ex. The first parameter can be displayed as *SEn.l* (mnemonic visualization) or as *P001* (numeric visualization)

13 Table of Configuration Parameters

GROUP A - *R.in.l* - Analogue input 1

1	<i>SEn.l</i>	Sensor AI1
Analogue input configuration / sensor AI1 selection		
<i>tc.k</i>	Tc-K	-260° C..1360° C. (Default)
<i>tc.S</i>	Tc-S	-40° C..1760° C
<i>tc.R</i>	Tc-R	-40° C..1760° C
<i>tc.J</i>	Tc-J	-200° C..1200° C
<i>tc.t</i>	Tc-T	-260° C..400° C
<i>tc.E</i>	Tc-E	-260° C..980° C
<i>tc.N</i>	Tc-N	-260° C..1280° C
<i>tc.b</i>	Tc-B	100° C..1820° C
<i>Pt100</i>	Pt100	-200° C..600° C
<i>Ni100</i>	Ni100	-60° C..180° C
<i>Ntc</i>	NTC 10K	-40° C..125° C
<i>Ptc</i>	PTC 1K	-50° C..150° C
<i>Pt500</i>	Pt500	-200° C..600° C
<i>Pt1k</i>	Pt1000	-200° C..600° C
<i>0-1</i>	0..1 V	
<i>0-5</i>	0..5 V	
<i>0-10</i>	0..10 V	
<i>0-20</i>	0..20 mA	
<i>4-20</i>	4..20 mA	
<i>0-60</i>	0..60 mV	
<i>Pot.</i>	Potentiometer (set the value on parameter 6)	

2 *dP.l* Decimal Point 1

Select number of displayed decimal points for AI1

0	Default
<i>0.0</i>	1 decimal
<i>0.00</i>	2 decimals
<i>0.000</i>	3 decimals

3 *dEGr.* Degree

<i>°C</i>	Celsius (Default)
<i>°F</i>	Fahrenheit
<i>K</i>	Kelvin

4 *LL.l.l* Lower Linear Input AI1

AI1 lower limit only for linear signals. Ex.: with input 4..20 mA this parameter takes value associated to 4 mA. The value may be greater than the one entered on the next parameter. **-9999..+30000 [digit]^[p.05] Default: 0.**

5 *UL.l.l* Upper Linear Input AI1

AI1 upper limit only for linear signals Ex: with input 4..20 mA this parameter takes value associated to 20 mA. The value may be lower than the one entered on the previous parameter. **-9999..+30000 [digit]^[p.05] Default:1000**

6 *P.v.R.l* Potentiometer Value AI1

Selects the value of the potentiometer connected on AI1 **1..150 kohm. Default: 10kohm**

7 **i.o.L.1** Linear Input over Limits AI1

If AI1 is a linear input, allows to the process to overpass the limits (Par. 3 and 4).

d.5Rb. Disabled (**Default**)

ENRb. Enabled

8 **o.c.R.1** Offset Calibration AI1

AI1 Offset calibration. Value added/subtracted to the process value (ex: usually correcting the ambient temperature value).

-9999..+9999 [digit^{1p.65}] (degrees.tenths for temperature sensors). **Default** 0.

9 **G.c.R.1** Gain Calibration AI1

Value multiplied to the process value to calibrate the working point. Ex: to correct the range from 0..1000°C showing 0..1010°C, set the parameter to -1.0

-100.0%...+100.0%, **Default**: 0.0.

10 **L.t.c.1** Latch-On AI1

Automatic setting of limits for AI1 linear input

d.5Rb. Disabled (**Default**)

SENRd Standard

V.0.5Eo. Virtual Zero Stored

V.0.k.oN. Virtual Zero at start

11 **c.F.L.1** Conversion Filter AI1

ADC Filter: Number of sensor readings to calculate mean that defines process value. **NB**: When readings increase, control loop speed slows down. 1...15. (**Default**: 10)

12 **c.Fr.1** Conversion Frequency AI1

Sampling frequency of digital / analogue converter for AI1. Increasing the conversion speed will slow down reading stability (example: for fast transients, as the pressure, it is advisable to increase sampling frequency)

4.17.HZ 4.17 Hz (Min. conversion speed)

6.25HZ 6.25 Hz

8.33HZ 8.33 Hz

10.0HZ 10.0 Hz

12.5HZ 12.5 Hz

16.7HZ 16.7 Hz (**Default**) Ideal for filtering noises 50 / 60 Hz

19.6HZ 19.6 Hz

33.2HZ 33.2 Hz

39.0HZ 39.0 Hz

50.0HZ 50.0 Hz

62.0HZ 62.0 Hz

123HZ 123 Hz

242HZ 242 Hz

470HZ 470 Hz (Max. speed conversion)

13÷17 **Reserved Parameters - Group A**

Reserved parameters - Group A

GROUP B - **R.in.2** - Analogue input 2

18 **SEr.2** Sensor AI2

Analogue input configuration / sensor AI2 selection

d.5Rb. Disabled Disabled. (**Default**)

t.c. K Tc-K -260° C..1360° C.

t.c. S Tc-S -40° C..1760° C

t.c. P Tc-R -40° C..1760° C

t.c. J Tc-J -200° C..1200° C

t.c. t Tc-T -260° C..400° C

t.c. E Tc-E -260° C..980° C

t.c. N Tc-N -260° C..1280° C

t.c. b Tc-B 100° C..1820° C

Pt100 Pt100 -200° C..600° C

Ni100 Ni100 -60° C..180° C

Ntc NTC 10K -40° C..125° C

Ptc PTC 1K -50° C..150° C

Pt500 Pt500 -200° C..600° C

Pt1K Pt1000 -200° C..600° C

0-1 0..1 V

0-5 0..5 V

0-10 0..10 V

0-20 0..20 mA

4-20 4..20 mA

0-60 0..60 mV

Pob. PPotentiometer (set the value on parameter 23)

19 **d.P.2** Decimal Point 2

Select number of displayed decimal points for AI 2

0 **Default**

0.0 1 decimal

0.00 2 decimals

0.000 3 decimals

20 **r.E5.** Reserved

Reserved parameter.

21 **L.L.i.2** Lower Linear Input AI2

AI2 lower limit only for linear signals. Ex.: with input 4..20 mA this parameter takes value associated to 4 mA. The value may be greater than the one entered on the next parameter.

-9999..+30000 [digit^{1p.65}] **Default**: 0.

22 **U.L.i.2** Upper Linear Input AI2

AI2 upper limit only for linear signals Ex: with input 4..20 mA this parameter takes value associated to 20 mA.The value may be lower than the one entered on the previous parameter..

-9999..+30000 [digit^{1p.65}] **Default**:1000

23 **P.u.R.2** Potentiometer Value AI2

Selects the value of the potentiometer connected on AI2

1..150 kohm. **Default**: 10kohm

24 **i.o.L.2** Linear Input over Limits AI2

If AI2 is a linear input, allows to the process to overpass the limits (Par. 18 and 19).

d.5Rb. Disabled (**Default**)

ENRb. Enabled

25 *a.c.R2* Offset Calibration AI2

AI2 Offset calibration. Value added/subtracted to the process value (ex: usually correcting the ambient temperature value).

-9999..+9999 [digit^{1/0..65}] (degrees.tenths for temperature sensors). **Default** 0.

26 *G.c.R2* Gain Calibration AI2

Value multiplied to the process value to calibrate the working point. Ex: to correct the range from 0..1000°C showing 0..1010°C, set the parameter to -1.0

-100.0%...+100.0%, **Default:** 0.0.

27 *L.t.c2* Latch-On AI2

Automatic setting of limits for AI2 linear input

d.5Rb. Disabled (**Default**)

5.t.NRd Standard

V.0.5t.o. Virtual Zero Stored

V.0.t.o.N Virtual Zero at start

28 *c.F.L2* Conversion Filter AI2

ADC Filter: Number of sensor readings to calculate mean that defines process value.

NB: When readings increase, control loop speed slows down.

1...15. (**Default:** 10)

29 *c.F.r2* Conversion Frequency AI2

Sampling frequency of digital / analogue converter for AI2.

Increasing the conversion speed will slow down reading stability

(example: for fast transients, as the pressure, it is advisable to increase sampling frequency).

4.17.HZ 4.17 Hz (Min. conversion speed)

6.25HZ 6.25 Hz

8.33HZ 8.33 Hz

10.0HZ 10.0 Hz

12.5HZ 12.5 Hz

16.7HZ 16.7 Hz (**Default**) Ideal for filtering noises 50 / 60 Hz

19.6HZ 19.6 Hz

33.2HZ 33.2 Hz

39.0HZ 39.0 Hz

50.0HZ 50.0 Hz

62.0HZ 62.0 Hz

123HZ 123 Hz

242HZ 242 Hz

470HZ 470 Hz (Max. speed conversion)

30÷34 Reserved Parameters - Group B

Reserved parameters - Group B

GROUP C - *c.N.d.1* - Outputs and regulation Process 1

35 *c.o.u.1* Command Output 1

Selects the command output related to the process1 and the outputs related to the alarms.

c. o2 Command on relay output Q2.

c. o1 Command on relay output Q1. (**Default**)

c. 55P Command on digital output

c. VRL. Sevo-valve command with open loop

c. 0-10 Command 0-10 V on analogue output AO1.

c. 4-20 Command 4-20 mA on analogue output AO1.

UR48481A and UR48482A

	Command	Alarm 1	Alarm 2	Alarm 3	Alarm 4
<i>c. o2</i>	Q2	Q1	DO1	DO2	AO1
<i>c. o1</i>	Q1	Q2	DO1	DO2	AO1
<i>c. 55P</i>	DO1	Q1	Q2	DO2	AO1
<i>c. VRL.</i>	Q1(open) Q2(close)	DO1	DO2	AO1	-
<i>c. 0-10</i>	AO1 (0..10 V)	Q1	Q2	DO1	DO2
<i>c. 4-20</i>	AO1 (4..20 mA)	Q1	Q2	DO1	DO2

UR48483A and UR48484A

	Command	AL. 1	AL. 2	AL. 3	AL. 4	AL. 5	AL. 6
<i>c. o2</i>	Q2	Q1	Q3	DO1	DO2	AO1	AO2
<i>c. o1</i>	Q1	Q2	Q3	DO1	DO2	AO1	AO2
<i>c. 55P</i>	DO1	Q1	Q2	Q3	DO2	AO1	AO2
<i>c. VRL.</i>	Q1(open) Q2(close)	Q3	DO1	DO2	AO1	AO2	-
<i>c. 0-10</i>	AO1 (0..10 V)	Q1	Q2	Q3	DO1	DO2	AO2
<i>c. 4-20</i>	AO1 (4..20 mA)	Q1	Q2	Q3	DO1	DO2	AO2

36 *c.P.1* Command Process 1 (*only for UR4843A and UR48484A*)

Selects process value related to process 1 and to command output 1.

R.i.N.1 Value read on input AI1. (**Default**)

R.i.N.2 Value read on input AI2.

MERN Arithmetic average of the value read on inputs AI1 and AI2 $[(AI1-AI2)/2]$.

d.FF. Difference of the values read on inputs AI1 and AI2 $(AI1-AI2)$.

Rb.d.F. Module of the difference of the values read on inputs AI1 and AI2 $(|AI1-AI2|)$.

SuM Sum of values read on inputs AI1 and AI2 $(AI1+AI2)$.

37 *r.E5.* Reserved

Reserved parameter.

38 *R.c.t.1* Action type 1

Action type to control process 1.

HEAT Heating (N.A.) (**Default**)

COOL Cooling (N.C.)

39 *c.HY.1* Command Hysteresis 1

Hysteresis to control process 1 in ON/OFF.

-9999..+9999 [digit^{1/0..65}] (degrees.tenths for temperature sensors). **Default** 0.2.

40 *LLS.1* Lower Limit Setpoint 1

Lower limit setpoint selectable for command setpoint 1.
-9999..+30000 [digit^{1 p.65}] (degrees.tenths for temperature sensors). **Default** 0.

41 *ULS.1* Upper Limit Setpoint 1

Upper limit setpoint selectable for command setpoint 1.
-9999..+30000 [digit^{1 p.65}] (degrees for temperature sensors). **Default** 1750.

42 *c.r.E.1* Command Reset 1

Type of reset for command contact 1 (always automatic in P.I.D. functioning)

- R.PES.* Automatic Reset (**Default**)
- M.PES.* Manual Reset (by keyboard or by digital input)
- M.PES.5.* Manual Reset Stored (keeps relay status also after an eventual power failure)

43 *c.S.E.1* Command State Error 1

State of contact for command 1 output in case of error.

If the command output 1 (Par. 35 *c.D.U.1*) is relay or valve:

- a.PEN* Contact or valve open. **Default**
- c.LoSE* Contact or valve closed.

If the command output 1 is digital output (SSR):

- a.FF* Digital output OFF. **Default**
- a.M* Digital output ON.

If the command output 1 is 0-10V:

- 0 V* 0 V. **Default**
- 10 V* 10 V.

If the command output 1 is 0-20 mA or 4-20 mA:

- 0 mA* 0 mA. **Default**
- 4 mA* 4 mA.
- 20 mA* 20 mA.
- 21.5 mA* 21.5 mA.

44 *c.Ld.1* Command Led 1

Defines led C1 state corresponding to the relevant output. If the valve command is selected, this parameter is not managed.

- a.c.* ON with open contact or SSR switched off. If command AO1, ON with output 0%, OFF if 100% and flashing between 1% and 99%.
- c.c.* ON with closed contact or SSR switched on. If command AO1 ON with output 100%, OFF if 0% and flashing between 1% and 99%. (**Default**)

45 *c.dE.1* Command Delay 1

Command 1 delay (only in ON / OFF functioning). In case of valves it works also in P.I.D. and represents delay between opening and closure of two contacts.

-3600..+3600 seconds (tenth of second in case of servo valve). **Default:** 0.

Negative: delay when turning off output.

Positive: delay when turning on output.

46 *c.S.P.1* Command Setpoint Protection 1

Allows or not to modify command setpoint 1 value

- FREE* Modification allowed (**Default**)
- LoK* Protected

47 *vRL.1* Valve Time 1

Valve time related to command 1 (declared by the manufacturer of the valve)

1...300 seconds. **Default:** 60.

48 *A.M.1* Automatic / Manual 1

Enables the automatic/manual selection for command 1

- d.SRb.* Disabled (**Default**)
- EMRb.* Enabled
- EM.5to.* Enabled with memory

49÷53 Reserved Parameters - Group C

Reserved parameters - Group C

GROUP D - *cPd.2* - Outputs and regulation Process 2

54 *c.D.U.2* Command Output 2 (only on UR48483A / 4A)

Selects the command output related to the process 2

- d.SRb.* Command disabled. (**Default**)
- c. a3* Command on relay output Q3
- c. SSR* Command on digital output DO2
- c. VRL* Sevo-valve command with open loop on DO1 (open) and DO2 (close)
- c.D. -10* Command 0-10 V on analogue output AO2
- c.Y-20* Command 4-20 mA on analogue output AO2

55 *c.Pr.2* Command Process 2 (only on UR48483A / 4A)

Selects process value related to process 2 and to command output 2.

- R.N.1* Value read on input AI1. (**Default**)
- R.N.2* Value read on input AI2.
- MERN* Arithmetic average of the value read on inputs AI1 and AI2 [(AI1-AI2)/2].
- d.FF.* Difference of the values read on inputs AI1 and AI2 (AI1-AI2).
- Rb.d.F.* Module of the difference of the values read on inputs AI1 and AI2 (|AI1-AI2|).
- Sum* Sum of values read on inputs AI1 and AI2 (AI1+AI2).

56 *rES.* Remote Setpoint (only on UR48483A / 4A)

Enables remote setpoint. The control setpoint is sent by another device and is received by a second analogue input (it is necessary to select on parameter *c.Pr.2* the selections *R.i. 1* or *R.i. 2*) or through serial.

- d.SRb.* Disabled. (**Default**)
- EMRb.* Enables remote setpoint by process 2. Remote/local selection can be done by digital input.
- EM.ESL.* Remote setpoint by process 2, Remote/local selection only by keyboard (not allowed by digital input)
- EM.SER.* Enables remote setpoint by serial input. Remote/local selection can be done by digital input.
- EM.SE.L.* Remote setpoint by serial, Remote/local selection only by keyboard (not allowed by digital input).
- cPd. 1* The reference setpoint of command 2 is the same of command 1.

57 *Rc.L.2* Action type 2

Action type to control process 2.

- HERL* Heating (N.A.) (**Default**)
- cool* Cooling (N.C.)

58 *c.H.2* Command Hysteresis 2

Hysteresis to control process 2 in ON/OFF.

-9999..+9999 [digit^{1 p.65}] (degrees.tenths for temperature sensors). **Default** 0.2.

59 *LLS.2* Lower Limit Setpoint 2

Lower limit setpoint selectable for command setpoint 2.

-9999..+30000 [digit^{1 p.65}] (degrees for temperature sensors). **Default** 0.

60 *uLS2* Upper Limit Setpoint 2

Lower limit setpoint selectable for command setpoint 2.
-9999..+30000 [digit^{1 p.65}] (degrees for temperature sensors). **Default** 1750.

61 *c.rE2* Command Reset 2

Type of reset for command contact 2 (always automatic in P.I.D. functioning)

R.PES. Automatic Reset (**Default**)

M.PES. Manual Reset (by keyboard or by digital input)

M.PES.5. Manual Reset Stored (keeps relay status also after an eventual power failure)

62 *cS.E2* Command State Error 2

State of contact for command 2 output in case of error.

If the command output 2 (Par. 54 *c.OU.2*) is relay or valve:

oPEN Contact or valve open. **Default**

cLoSE Contact or valve closed.

If the command output 2 is digital output (SSR):

oFF Digital output OFF. **Default**

oN Digital output ON.

If the command output 2 is 0-10V:

0 V 0 V. **Default**

10 V 10 V.

If the command output 2 is 0-20 mA or 4-20 mA:

0 mA 0 mA. **Default**

4 mA 4 mA.

20 mA 20 mA.

21.5 mA 21.5 mA.

63 *c.Ld.2* Command Led 2

Defines led  state corresponding to the relevant output. If the valve command is selected, this parameter is not managed.

o.c. ON with open contact or SSR switched off. If command AO2, ON with output 0%, OFF if 100% and flashing between 1% and 99%.

c.c. ON with closed contact or SSR switched on. If command AO2 ON with output 100%, OFF if 0% and flashing between 1% and 99%. (**Default**)

64 *c.dE2* Command Delay 2

Command 2 delay (only in ON / OFF functioning). In case of valves it works also in P.I.D. and represents delay between opening and closure of two contacts.

-3600..+3600 seconds (tenth of second in case of servo valve). **Default**: 0.

Negative: delay when turning off output.

Positive: delay when turning on output.

65 *cS.P.2* Command Setpoint Protection 2

Allows or not to modify command setpoint 2 value

FREE Modification allowed (**Default**)

LoCK Protected

66 *vR.t.2* Valve Time 2

Valve time related to command 2 (declared by the manufacturer of the valve)

1...300 seconds. **Default**: 60.

67 *A.MA.2* Automatic / Manual 2

Enables the automatic/manual selection for command 2

d.SRb. Disabled (**Default**)

ENRb. Enabled

EM.5to. Enabled with memory

68÷72 Reserved Parameters - Group D

Reserved parameters - Group D

GROUP E - *rEQ.1* - Autotuning and PID 1

73 *tUn.1* Tune 1

Selects autotuning type for command 1

d.SRb. Disabled. If proportional band and integral time parameters are to be selected to zero, the regulation is ON/OFF type.. (**Default**)

Auto Automatic (Automatic P.I.D. parameters calculation)

MANU. Manual (launch by keyboards or by digital input)

oMCE Once (P.I.D. parameters calculation only at first start)

SYNCH. Synchronized (Autotuning managed by serial)

74 *S.d.t.1* Setpoint Deviation Tune 1

Selects deviation from command setpoint 1 as threshold used by autotuning to calculate P.I.D. parameters

0-10000 [digit^{1 p.65}] (degrees.tenths for temp. sensors). **Default**: 30.0.

75 *P.b. 1* Proportional Band 1

Proportional band or process 1 P.I.D. regulation (Process inertia).

0 ON / OFF if t.i. equal to 0 (**Default**)

1...10000 [digit^{1 p.65}] (degrees.tenths for temp. sensors).

76 *i.t. 1* Integral Time 1

Integral time for process 1 P.I.D. regulation (process inertia duration).

0.0...2000.0 secondi (0.0 = integral disabled), **Default** 0.0

77 *d.t. 1* Derivative Time 1

Derivative time for process 1 P.I.D. regulation (Normally ¼ of integral time).

0.0...1000.0 secondi (0.0 = derivative disabled), **Default** 0

78 *d.b. 1* Dead Band 1

Dead band of process 1 P.I.D..

0...10000 [digit^{1 p.65}] (degrees.tenths for temp. sensors) (**Default**: 0)

79 *P.b.c.1* Proportional Band Centered 1

Defines if the proportional band 1 must be centered or not on the setpoint. In double loop functioning (heating/cooling), always disabled.

d.SRb. Disabled. Band under (heating) or over (cooling)(**Default**)

ENRb. Centered band

80 *o.o.S.1* Off Over Setpoint 1

In P.I.D. enables the command output 1 switching off, when a certain threshold is exceeded (setpoint + Par.81)

d.SRb. Disabled (**Default**)

ENRb. Enabled

- 81** *o.d.t.1* **Off Deviation Threshold 1**
Selects deviation from command setpoint 1, to calculate the intervention threshold of "Off Over Setpoint 1" function.
-9999...+9999 [digit^{1 p. 65}] (degrees.tenths for temp. sensors) **(Default: 0)**
- 82** *c.t. 1* **Cycle Time 1**
Cycle time for P.I.D. regulation of process 1 (for P.I.D. on remote control switch 15 s; for PID on SSR 2s). For valve refer to parameter 47 *uR.t.1*
1-300 seconds **(Default:15 s)**
- 83** *co.F.1* **Cooling Fluid 1**
Type of refrigerant fluid for heating / cooling P.I.D. for process 1. Enable the cooling output on parameter AL.1... AL.6.
R.R Air **(Default)**
o.i Oil
WATER Water
- 84** *Pb.1.1* **Proportional Band Multiplier 1**
Proportional band multiplier for heating/cooling P.I.D. for process 1. Proportional band for cooling action is given by parameter *P.b. 1* multiplied for this value
1.00...5.00. **Default: 1.00**
- 85** *o.d.b.1* **Overlap / Dead Band 1**
Dead band combination for heating / cooling P.I.D. (double action) for process 1.
-20.0%...50.0%
Negative: Dead band.
Positive: overlap. **Default: 0.0%**
- 86** *c.c.t.1* **Cooling Cycle Time 1**
Cycle time for cooling output in heating/cooling P.I.D. mode for process 1.
1-300 seconds **(Default:10 s)**
- 87** *LLP.1* **Lower Limit Output Percentage 1**
Selects min. value for command output 1 percentage.
0%...100%, **Default: 0%**.
- 88** *uL.P.1* **Upper Limit Output Percentage 1**
Selects max. value for command output 1 percentage.
0%...100%, Default: 100%.
- 89** *P.G.t.1* **Max Gap Tune 1**
Selects the max. process-setpoint gap beyond which the automatic tune recalculates PID parameters of process 1.
0-10000 [digit^{1 p. 65}] (degrees.tenths for temp. sensors). **Default: 2.0**
- 90** *Pn.P.1* **Minimum Proportional Band 1**
Selects the min. proportional band 1 value selectable by the automatic tune for the P.I.D. regulation of process 1.
0-10000 [digit^{1 p. 65}] (degrees.tenths for temp. sensors). **Default: 3.0**
- 91** *PR.P.1* **Maximum Proportional Band 1**
Selects the max. proportional band 1 value selectable by the automatic tune for the P.I.D. regulation of process 1.
0-10000 [digit^{1 p. 65}] (degrees.tenths for temp. sensors). **Default: 80.0**

- 92** *Pn.i.1* **Minimum Integral Time 1**
Selects the min. integral time 1 value selectable by the automatic tune for the P.I.D. regulation of process 1.
0.0...1000.0 seconds. **Default: 30.0 s.**

- 93** *o.c.L.1* **Overshoot Control Level 1**
The overshoot control function prevents this event during device switching on or when the setpoint is modified.
Setting a too low value the overshoot may not be fully absorbed, while with high values the process could reach the setpoint more slowly.
Disab. Lev. 6
Lev. 1 Lev. 7
Lev. 2 Lev. 8
Lev. 3 Lev. 9
Lev. 4 Lev. 10
Lev. 5 **(Default)**

- 94÷97** **Reserved Parameters - Group E**
Reserved parameters - Group E

GROUP F - *rEE2* - Autotuning and PID 2

- 98** *tun.2* **Tune 2**
Selects autotuning type for command 2
d.SRb. Disabled. If proportional band and integral time parameters are selected to zero, the regulation is ON/OFF type. **(Default)**
Auto Automatic (Automatic P.I.D. parameters calculation)
MANU. Manual (launch by keyboards or by digital input)
once Once (P.I.D. parameters calculation only at first start)
Synch. Synchronized (Autotuning managed by serial)

- 99** *S.d.t.2* **Setpoint Deviation Tune 2**
Selects deviation from command setpoint 2 as threshold used by autotuning to calculate P.I.D. parameters.
0-10000 [digit^{1 p. 65}] (degrees.tenths for temp. sensors). **Default: 30.0.**

- 100** *P.b. 2* **Proportional Band 2**
Proportional band or process 2 P.I.D. regulation (Process inertia).
0 ON / OFF if t.i. equal to 0 **(Default)**
1...10000 [digit^{1 p. 65}] (degrees.tenths for temp. sensors).

- 101** *i.t. 2* **Integral Time 2**
Integral time for process 2 P.I.D. regulation (process inertia duration).
0.0...2000.0 seconds (0.0 = integral disabled), **Default 0.0**

- 102** *d.t. 2* **Derivative Time 2**
Derivative time for process 2 P.I.D. regulation (Normally ¼ of integral time).
0.0...1000.0 seconds (0.0 = derivative disabled), **Default 0**

- 103** *d.b. 2* **Dead Band 2**
Dead band of process 2 P.I.D.
0...10000 [digit^{1 p. 65}] (degrees.tenths for temp. sensors) **(Default: 0)**

104 *P.b.c.2* **Proportional Band Centered 2**
 Defines if the proportional band 2 must be centered or not on the setpoint. In double loop functioning (heating/cooling), always disabled.
d.SRb. Disabled. Band under (heating) or over (cooling) (**Default**)
ENRb. Centered band

105 *o.o.S.2* **Off Over Setpoint 2**
 In P.I.D. enables the command output 2 switching off, when a certain threshold is exceeded (setpoint + Par.106)
d.SRb. Disabled (**Default**)
ENRb. Enabled

106 *o.d.t.2* **Off Deviation Threshold 2**
 Selects deviation from command setpoint 2, to calculate the intervention threshold of "Off Over Setpoint 2" function.
 -9999...+9999 [digit^{1 p. 65}] (degrees.tenths for temp. sensors) (**Default**: 0)

107 *c.t. 2* **Cycle Time 2**
 Cycle time for P.I.D. regulation of process 2 (for P.I.D. on remote control switch 15 s; for PID on SSR 2s). For valve refer to parameter *μA.t.2*
 1-300 seconds (**Default**:15 s)

108 *co.F.2* **Cooling Fluid 2**
 Type of refrigerant fluid for heating / cooling P.I.D. for process 2. Enable the cooling output on parameter AL.1... AL.6.
RiP Air (**Default**)
o.i Oil
WRLEP Water

109 *P.b.Π.2* **Proportional Band Multiplier 2**
 Proportional band multiplier for heating/cooling P.I.D. for process 2. Proportional band for cooling action is given by parameter *P.b. 2* multiplied for this value.
 1.00..5.00. **Default**: 1.00

110 *o.d.b.2* **Overlap / Dead Band 2**
 Dead band combination for heating / cooling P.I.D. (double action) for process 2.
 -20.0..50.0%
 Negative: Dead band.
 Positive: overlap. **Default**: 0.0%

111 *c.c.t.2* **Cooling Cycle Time 2**
 Cycle time for cooling output in heating/cooling P.I.D. mode for process 2.
 1-300 seconds (**Default**:10 s)

112 *LLP.2* **Lower Limit Output Percentage 2**
 Selects min. value for command output 2 percentage.
 0%...100%, **Default**: 0%.

113 *ULP.2* **Upper Limit Output Percentage 2**
 Selects max. value for command output 2 percentage.
 0%...100%, **Default**: 100%.

114 *Π.G.t.2* **Max Gap Tune 2**
 Selects the max. process-setpoint gap beyond which the automatic tune recalculates PID parameters of process 2.
 0-10000 [digit^{1 p. 65}] (degrees.tenths for temp. sensors). **Default**: 2.0

115 *Π.n.P.2* **Minimum Proportional Band 2**
 Selects the min. proportional band value selectable by the automatic tune for the P.I.D. regulation of process 2.
 0-10000 [digit^{1 p. 65}] (degrees.tenths for temp. sensors). **Default**: 3.0

116 *ΠA.P.2* **Maximum Proportional Band 2**
 Selects the max. proportional band 2 value selectable by the automatic tune for the P.I.D. regulation of process 2.
 0-10000 [digit^{1 p. 65}] (degrees.tenths for temp. sensors). **Default**: 80.0

117 *Π.n.i.2* **Minimum Integral Time 2**
 Selects the min. integral time 2 value selectable by the automatic tune for the P.I.D. regulation of process 2.
 0.0...1000.0 secondS. **Default**: 30.0 secondi.

118 *o.c.L.2* **Overshoot Control Level 2**
 The overshoot control function prevents this event during device switching on or when the setpoint is modified.
 Setting a too low value the overshoot may not be fully absorbed, while with high values the process could reach the setpoint more slowly.

Disab.	Lev. 6
Lev. 1	Lev. 7
Lev. 2	Lev. 8
Lev. 3	Lev. 9
Lev. 4	Lev. 10
Lev. 5 (Default)	

119÷122 **Reserved Parameters - Group F**
 Reserved parameters - Group F

GROUP G - AL. 1- ALARM 1

123 *AL.F.* Alarm 1 Function

Alarm 1 selection.

- d15Rb.* Disabled (**Default**)
- Rb.uP.R.* Absolute Upper Activation. Absolute referred to the process, active over
- Rb.Lo.R.* Absolute Lower Activation. Absolute referred to the process, active under
- bRMd* Band alarm (command setpoint ± alarm setpoint)
- uP.dEV.* Upper Deviation alarm
- Lo.dEV.* Lower Deviation alarm
- Rb.c.u.R.* Absolute Command Upper Activation. Absolute alarm referred to the command setpoint, active over
- Rb.c.L.R.* Absolute Command Lower Activation. Absolute alarm referred to the command setpoint, active under
- RdN* Status alarm (active in RUN/START)
- codL* Cold actuator auxiliary (Cold action in double loop)
- PPb.ER.* Probe error. Alarm active in case of sensor ropture.
- tMP.1* Related to timer 1
- tMP.2* Related to timer 2
- tMP.1.2* Related to both timers
- REM.* Remote. The alarm is enabled by the word 1235
- d.i. 1* Digital Input 1. Active when digital input 1 is active.
- d.i. 2* Digital Input 2. Active when digital input 2 is active.
- d.i. 3* Digital Input 3. Active when digital input 3 is active.
- d.i. 4* Digital Input 4. Active when digital input 4 is active.
- H.b.R.* Heater Break Alarm and Overcurrent Alarm

124 *R.IP.* Alarm 1 Process (only on UR48483A / 4A)

Selects the size related to alarm 1.

- R.i.N.1* Value read on input AI1. (**Default**)
- R.i.N.2* Value read on input AI2.
- MERH* Arithmetic average of the value read on inputs AI1 and AI2 $[(AI1+AI2)/2]$.
- d1FF.* Difference of the values read on inputs AI1 and AI2 $(AI1-AI2)$.
- Rb.d1F.* Module of the difference of the values read on inputs AI1 and AI2 $(|AI1-AI2|)$.
- SuM* Sum of values read on inputs AI1 and AI2 $(AI1+AI2)$.

125 *RJ.r.c.* Alarm 1 Reference Command

Selects alarm 1 reference command

- cMd. 1* Alarm referred to command 1. (**Default**)
- cMd. 2* Alarm referred to command 2.

126 *RJ.S.o.* Alarm 1 State Output

Alarm 1 output contact and intervention type.

- N.o. 5E.* (N.O. Start) Normally open, active at start (**Default**)
- N.c. 5E.* (N.C. Start) Normally closed, active at start
- N.o. tH.* (N.O. Threshold) Normally open, active on reaching alarm^{2p.65}
- N.c. tH.* (N.C. Threshold) Normally closed, active on reaching alarm^{2p.65}

127 *rES.* Reserved

Reserved parameter.

128 *R.HY.* Alarm 1 Hysteresis

Alarm 1 hysteresis

-9999..+9999 [digit^{1p.65}] (degrees for temp. sensors). **Default** 0.5.

129 *R.LL.* Alarm 1 Lower Limit

Lower limit selectable for the alarm 1 setpoint.

-9999..+30000 [digit^{1p.65}] (degrees for temp. sensors). **Default** 0.

130 *R.LuL.* Alarm 1 Upper Limit

Upper limit selectable for the alarm 1 setpoint

-9999..+30000 [digit^{1p.65}] (degrees for temp. sensors). **Default** 1750.

131 *R.l.r.E.* Alarm 1 Reset

Alarm 1 contact reset type

- R. RES.* Automatic reset (**Default**)
- M. RES.* Manual reset (manual reset by keyboard or by digital input)
- M.RES.5.* Stored manual reset (keeps the output status also after a power failure)

132 *R.I.S.E.* Alarm 1 State Error

Alarm 1 output status in case of error.

- oPEN* Open contact. **Default**
- cLoSE* Closed contact.

133 *R.Ld.* Alarm 1 Led

Defines the status of the led **A1** in correspondence of the relevant output

- o.c.* ON with open contact or DO switched off.
- c.c.* ON with closed contact or DO switched on. (**Default**)

134 *R.LdE.* Alarm 1 Delay

Alarm 1 Delay.

-3600..+3600 seconds. **Default:** 0.

Negative value: delay when exit alarm status.

Positive value: delay when enter alarm status.

135 *R.I.S.P.* Alarm 1 Setpoint Protection

Allows or not to change the alarm 1 setpoint

- FPEE* Editable by the user (**Default**)
- LoCK* Protected
- HidE* Protected and not visualized

136 *R.Lb.* Alarm 1 Label

Selects the message to be visualized in case of alarm 1 intervention

0 Disabled. **Default** 0.

1-20 Message 1..20 (Vedi tabella messaggi personalizzabili)

137÷140 Reserved Parameters - Group G

Reserved parameters - Group G

GRUPPO H - AL. 2 - Alarm 2

141 *AL2F.* Alarm 2 Function

Alarm 2 selection.

- d15Rb.* Disabled (**Default**)
- Rb.uP.R.* Absolute Upper Activation. Absolute referred to the process, active over
- Rb.Lo.R.* Absolute Lower Activation. Absolute referred to the process, active under
- bRMd* Band alarm (command setpoint ± alarm setpoint)
- uP.dEV.* Upper Deviation alarm
- Lo.dEV.* Lower Deviation alarm
- Rb.c.u.R.* Absolute Command Upper Activation. Absolute alarm referred to the command setpoint, active over
- Rb.c.L.R.* Absolute Command Lower Activation. Absolute alarm referred to the command setpoint, active under
- RdN* Status alarm (active in RUN/START)
- codL* Cold actuator auxiliary (Cold action in double loop)
- PPb.ER.* Probe error. Alarm active in case of sensor rupture.
- tMR.1* Related to timer 1
- tMR.2* Related to timer 2
- tMR.1.2* Related to both timers
- REM.* Remote. The alarm is enabled by the word 1236
- d.i. 1* Digital Input 1. Active when digital input 1 is active.
- d.i. 2* Digital Input 2. Active when digital input 2 is active.
- d.i. 3* Digital Input 3. Active when digital input 3 is active.
- d.i. 4* Digital Input 4. Active when digital input 4 is active.
- H.b.R.* Heater Break Alarm and Overcurrent Alarm

142 *R2Pr.* Alarm 2 Process (only on UR48483A / 4A)

Selects the size related to alarm 2.

- R.iN.1* Value read on input AI1. (**Default**)
- R.iN.2* Value read on input AI2.
- MERH* Arithmetic average of the value read on inputs AI1 and AI2 $[(AI1+AI2)/2]$.
- d1FF.* Difference of the values read on inputs AI1 and AI2 $(AI1-AI2)$.
- Rb.d1F.* Module of the difference of the values read on inputs AI1 and AI2 $(|AI1-AI2|)$.
- SuM* Sum of values read on inputs AI1 and AI $(AI1+AI2)$.

143 *R2r.c.* Alarm 2 Reference Command

Selects alarm 2 reference command

- cMd. 1* Alarm referred to command 1. (**Default**)
- cMd. 2* Alarm referred to command 2.

144 *R2S.o.* Alarm 2 State Output

Alarm 2 output contact and intervention type.

- N.o. 5E.* (N.O. Start) Normally open, active at start (**Default**)
- N.c. 5E.* (N.C. Start) Normally closed, active at start
- N.o. tH.* (N.O. Threshold) Normally open, active on reaching alarm^{2p.65}
- N.c. tH.* (N.C. Threshold) Normally closed, active on reaching alarm^{2p.65}

145 *rES.* Reserved

Reserved parameter.

146 *R2HY.* Alarm 2 Hysteresis

Alarm 2 hysteresis

-9999..+9999 [digit^{1p.65}] (degrees for temp. sensors). **Default** 0.5.

147 *R2LL.* Alarm 2 Lower Limit

Lower limit selectable for the alarm 2 setpoint.

-9999..+30000 [digit^{1p.65}] (degrees for temp. sensors). **Default** 0.

148 *R2UL.* Alarm 2 Upper Limit

Upper limit selectable for the alarm 2 setpoint

-9999..+30000 [digit^{1p.65}] (degrees for temp. sensors). **Default** 1750.

149 *R2rE.* Alarm 2 Reset

Alarm 2 contact reset type

- R. RES.* Automatic reset (**Default**)
- M. RES.* Manual reset (manual reset by keyboard or by digital input)
- M.RES.5.* Stored manual reset (keeps the output status also after a power failure)

150 *R2SE.* Alarm 2 State Error

Alarm 2 output status in case of error

If the alarm output is relay

aPEN Contact or open valve. **Default** *cLo5E* Contact or closed valve.

If the alarm output is digital (SSR):

aFF Digital output OFF. **Default** *aH* Digital output ON.

151 *R2Ld.* Alarm 2 Led

Defines the status of the led **A2** in correspondence of the relevant output.

- a.c.* ON with open contact or DO switched off.
- c.c.* ON with closed contact or DO switched on. (**Default**)

152 *R2dE.* Alarm 2 Delay

Alarm 2 Delay.

-3600..+3600 seconds. **Default:** 0.

Negative value: delay when exit alarm status.

Positive value: delay when enter alarm status

153 *R2SP.* Alarm 2 Setpoint Protection

Allows or not to change the alarm 2 setpoint

- FREE* Editable by the user (**Default**)
- LoCK* Protected
- HiDE* Protected and not visualized

154 *R2Lb.* Alarm 2 Label

Selects the message to be visualized in case of alarm 2 intervention

- 0 Disabled. **Default** 0.
- 1-20 Message 1..20 (see customizable messages table)

155÷158 Reserved Parameters - Group H

Reserved parameters - Group H

GROUP I - AL. 3 - Alarm 3

159 *AL3.F.* Alarm 3 Function

Alarm 3 selection.

- d15Rb.* Disabled (**Default**)
- Rb.uP.R.* Absolute Upper Activation. Absolute referred to the process, active over
- Rb.Lo.R.* Absolute Lower Activation. Absolute referred to the process, active under
- bRNd* Band alarm (command setpoint ± alarm setpoint)
- uP.dEV.* Upper Deviation alarm
- Lo.dEV.* Lower Deviation alarm
- Rb.c.u.R.* Absolute Command Upper Activation. Absolute alarm referred to the command setpoint, active over
- Rb.c.L.R.* Absolute Command Lower Activation. Absolute alarm referred to the command setpoint, active under
- RuN* Status alarm (active in RUN/START)
- cooL* Cold actuator auxiliary (Cold action in double loop)
- PRb.EP.* Probe error. Alarm active in case of sensor rupture.
- tMR.1* Related to timer 1
- tMR.2* Related to timer 2
- tMR.1.2* Related to both timers
- REM.* Remote. The alarm is enabled by the word 1237
- d.i. 1* Digital Input 1. Active when digital input 1 is active.
- d.i. 2* Digital Input 2. Active when digital input 2 is active.
- d.i. 3* Digital Input 3. Active when digital input 3 is active.
- d.i. 4* Digital Input 4. Active when digital input 4 is active.
- H.b.R.* Heater Break Alarm e Overcurrent Alarm

160 *R3P.* Alarm 3 Process (only on UR48483A / 4A)

Selects the size related to alarm 3.

- R.i.N.1* Value read on input AI1. (**Default**)
- R.i.N.2* Value read on input AI2.
- MERH* Arithmetic average of the value read on inputs AI1 and AI2 [(AI1+AI2)/2].
- d1FF.* Difference of the values read on inputs AI1 and AI2 (AI1-AI2).
- Rb.d1F.* Module of the difference of the values read on inputs AI1 and AI2 (|AI1-AI2|).
- Sum* Sum of values read on inputs AI1 and AI2 (AI1+AI2).

161 *R3.r.c.* Alarm 3 Reference Command

Selects alarm 3 reference command

- cMd. 1* Alarm referred to command 1. (**Default**)
- cMd. 2* Alarm referred to command 2.

162 *R3S.o.* Alarm 3 State Output

Alarm 3 output contact and intervention type..

- N.o. 5E.* (N.O. Start) Normally open, active at start (**Default**)
- N.c. 5E.* (N.C. Start) Normally closed, active at start
- N.o. tH.* (N.O. Threshold) Normally open, active on reaching alarm^{2p.65}
- N.c. tH.* (N.C. Threshold) Normally closed, active on reaching alarm^{2p.65}

163 *R3.o.t.* Alarm 3 Output Type

Defines the output type if the alarm 3 is analogue.

- 0.10 V* Output 0...10 V. **Default**
- 4.20mA* Output 4...20 mA.

164 *R3H.* Alarm 3 Hysteresis

Alarm 3 hysteresis.

-9999..+9999 [digit^{1p.65}] (degrees for temp. sensors). **Default** 0.5.

165 *R3LL* Alarm 3 Lower Limit

Lower limit selectable for the alarm 3 setpoint.

-9999..+30000 [digit^{1p.65}] (degrees for temp. sensors). **Default** 0.

166 *R3.uL.* Alarm 3 Upper Limit

Upper limit selectable for the alarm 3 setpoint

-9999..+30000 [digit^{1p.65}] (degrees for temp. sensors). **Default** 1750.

167 *R3.r.E.* Alarm 3 Reset

Alarm 3 contact reset type.

- R. RES.* Automatic reset (**Default**)
- M. RES.* Manual reset (manual reset by keyboard or by digital input)
- M.RES.5.* Stored manual reset (keeps the output status also after a power failure)

168 *R3S.E.* Alarm 3 State Error

Alarm 3 output status in case of error.

If the alarm output is relay

aPEN Contact or open valve. **Default** *cLo5E* Contact or closed valve.

If the alarm output is digital (SSR):

aFF Digital output OFF. **Default** *aN* Digital output ON.

If the alarm output is 0-10V:

0 V 0 V. **Default** *10 V* 10 V.

If the alarm output is 0-20 mA or 4-20 mA:

0 mA 0 mA. **Default** *20 mA* 20 mA.
4 mA 4 mA. *21.5mA* 21.5 mA.

169 *R3Ld.* Alarm 3 Led

Defines the status of the led **A3** in correspondence of the relevant output.

- a.c.* ON with open contact, DO switched off or AO deactivated.
- c.c.* ON with closed contact, DO switched on or AO activated. (**Default**)

170 *R3.dE.* Alarm 3 Delay

Alarm 3 Delay.

-3600..+3600 seconds. **Default:** 0.

Negative value: delay when exit alarm status.

Positive value: delay when enter alarm status

171 *R3S.P.* Alarm 3 Setpoint Protection

Allows or not to change the alarm 3 setpoint.

- FPRE* Editable by the user (**Default**)
- LoCK* Protected
- HidE* Protected and not visualized

172 *R3Lb.* Alarm 3 Label

Selects the message to be visualized in case of alarm 3 intervention0

Disabled. **Default** 0.

1-20 Message 1..20 (see customizable messages table)

173÷176 Reserved Parameters - Group I

Reserved parameters - Group I

GROUP J - AL 4 - Alarm 4

177 *AL4.F.* Alarm 4 Function

Alarm 4 selection.

- d15Ab.* Disabled (**Default**)
- Ab.uP.R.* Absolute Upper Activation. Absolute referred to the process, active over
- Ab.Lo.R.* Absolute Lower Activation. Absolute referred to the process, active under
- bPAd* Band alarm (command setpoint ± alarm setpoint)
- uP.dEv.* Upper Deviation alarm
- Lo.dEv.* Lower Deviation alarm
- Ab.c.u.R.* Absolute Command Upper Activation. Absolute alarm referred to the command setpoint, active over
- Ab.c.l.R.* Absolute Command Lower Activation. Absolute alarm referred to the command setpoint, active under.
- RuN* Status alarm (active in RUN/START)
- cooL* Cold actuator auxiliary (Cold action in double loop)
- PPb.EP.* Probe error. Alarm active in case of sensor ropture.
- tMP.1* Related to timer 1
- tMP.2* Related to timer 2
- tMP.1.2* Related to both timers
- REM.* Remote. The alarm is enabled by the word 1238
- d.i. 1* Digital Input 1. Active when digital input 1 is active.
- d.i. 2* Digital Input 2. Active when digital input 2 is active.
- d.i. 3* Digital Input 3. Active when digital input 3 is active.
- d.i. 4* Digital Input 4. Active when digital input 4 is active.
- H.b.R.* Heater Break Alarm and Overcurrent Alarm

178 *RP.* Alarm 4 Process (only on UR48483A / 4A)

Selects the size related to alarm 4.

- R.i.N.1* Value read on input AI1. (**Default**)
- R.i.N.2* Value read on input AI2.
- MERH* Arithmetic average of the value read on inputs AI1 and AI2 [(AI1+AI2)/2].
- d1FF.* Difference of the values read on inputs AI1 and AI2 (AI1-AI2).
- Ab.d1F.* Module of the difference of the values read on inputs AI1 and AI2(|AI1-AI2|).
- SuM* Sum of values read on inputs AI1 and AI2 (AI1+AI2).

179 *AL4.c.* Alarm 4 Reference Command

Selects alarm 4 reference command

- cMd. 1* Alarm referred to command 1. (**Default**)
- cMd. 2* Alarm referred to command 2.

180 *AL5.o.* Alarm 4 State Output

Alarm 4 output contact and intervention type.

- N.o. St.* (N.O. Start) Normally open, active at start (**Default**)
- N.c. St.* (N.C. Start) Normally closed, active at start
- N.o. tH.* (N.O. Threshold) Normally open, active on reaching alarm^{2 p. 65}
- N.c. tH.* (N.C. Threshold) Normally closed, active on reaching alarm^{2 p. 65}

181 *AL.o.t.* Alarm 4 Output Type

Defines the output type if the alarm 4 is analogue.

- 0.10 V* Output 0...10 V. **Default**
- 4.20mA* Output 4...20 mA.

182 *AL4.H.* Alarm 4 Hysteresis

Alarm 4 hysteresis.

-9999..+9999 [digit^{1 p. 65}] (degrees for temp. sensors). **Default** 0.5.

183 *AL.L.* Alarm 4 Lower Limit

Lower limit selectable for the alarm 4 setpoint.

-9999..+30000 [digit^{1 p. 65}] (gradi per sensori di temperatura). **Default** 0.

184 *AL.u.L.* Alarm 4 Upper Limit

Upper limit selectable for the alarm 4 setpoint.

-9999..+30000 [digit^{1 p. 65}] (degrees for temp. sensors). **Default** 1750.

185 *AL.r.E.* Alarm 4 Reset

Alarm 4 contact reset type.

- R. RES.* Automatic reset (**Default**)
- M. RES.* Manual reset (manual reset by keyboard or by digital input)
- M.RES.5.* Stored manual reset (keeps the output status also after a power failure)

186 *AL5.E.* Alarm 4 State Error

Alarm 4 output status in case of error.

If the alarm output is digital (SSR):

oFF Digital output OFF. **Default** *oN* Digital output ON.

If the alarm output is 0-10V:

0 V 0 V. **Default** *10 V* 10 V.

If the alarm output is 0-20 mA or 4-20 mA:

0 mA 0 mA. **Default** *20 mA* 20 mA.
4 mA 4 mA. *21.5mA* 21.5 mA.

187 *r.E.* Reserved

Reserved parameter

188 *AL.d.E.* Alarm 4 Delay

Alarm 4 Delay.

-3600..+3600 seconds. **Default:** 0.

Negative value: delay when exit alarm status.

Positive value: delay when enter alarm status

189 *AL5.P.* Alarm 4 Setpoint Protection

Allows or not to change the alarm 4 setpoint.

- FREE* Editable by the user (**Default**)
- LoCK* Protected
- HidE* Protected and not visualized

190 *AL.Lb.* Alarm 4 Label

Selects the message to be visualized in case of alarm 4 intervention

- 0* Disabled. **Default** 0.
- 1-20* Message 1..20 (Vedi tabella messaggi personalizzabili)

191÷194 Reserved Parameters - Group J

Reserved parameters - Group J

GROUP K - AL. 5 - Alarm 5 (only on -23ABC-T)

195 *AL5.F.* Alarm 5 Function

Alarm 5 selection 5.

d15Rb. Disabled (**Default**)

Rb.uP.R. Absolute Upper Activation. Absolute referred to the process, active over

Rb.Lo.R. Absolute Lower Activation. Absolute referred to the process, active under

bRNd Band alarm (command setpoint ± alarm setpoint)

uP.dEV. Upper Deviation. alarm

Lo.dEV. Lower Deviation alarm

Rb.c.u.R. Absolute Command Upper Activation. Absolute alarm referred to the command setpoint, active over.

Rb.c.L.R. Absolute Command Lower Activation. Absolute alarm referred to the command setpoint, active under

RuN Status alarm (active in RUN/START)

cooL Cold actuator auxiliary (Cold action in double loop)

PPb.EP. Probe error. Alarm active in case of sensor rupture.

tMP.1 Related to timer 1

tMP.2 Related to timer 2

tMP.1.2 Related to both timers

REM. Remote. The alarm is enabled by the word 1239

d.i. 1 Digital Input 1. Active when digital input 1 is active.

d.i. 2 Digital Input 2. Active when digital input 2 is active.

d.i. 3 Digital Input 3. Active when digital input 3 is active.

d.i. 4 Digital Input 4. Active when digital input 4 is active.

H.b.R. Heater Break Alarm and Overcurrent Alarm

196 *ASPr.* Alarm 5 Process (only on AUR48483A / 4A)

Selects the size related to alarm 5.

R.i.N.1 Value read on input AI1. (**Default**)

R.i.N.2 Value read on input AI2.

MERH Arithmetic average of the value read on inputs AI1 and AI2 [(AI1+AI2)/2].

d1FF. Difference of the values read on inputs AI1 and AI2 (AI1-AI2).

Rb.d1F. Module of the difference of the values read on inputs AI1 and AI2 (|AI1-AI2|).

Sum Sum of values read on inputs AI1 and AI2 (AI1+AI2).

197 *AS.r.c.* Alarm 5 Reference Command

Selects alarm 5 reference command

cMd. 1 Alarm referred to command 1. (**Default**)

cMd. 2 Alarm referred to command 2.

198 *AS.o.* Alarm 5 State Output

Contatto uscita allarme 5 e tipo intervento.

N.o. 5E. (N.O. Start) Normally open, active at start (**Default**)

N.c. 5E. (N.C. Start) Normally closed, active at start

N.o. tH. (N.O. Threshold) Normally open, active on reaching alarm^{2 p. 65}

N.c. tH. (N.C. Threshold) Normally closed, active on reaching alarm^{2 p. 65}

199 *AS.o.t.* Alarm 5 Output Type

Defines the output type if the alarm 5 is analogue.

0.10V Output 0...10 V. **Default**

4.20mA Output 4...20 mA.

200 *AS.HY.* Alarm 5 Hysteresis

Alarm 5 hysteresis.

-9999..+9999 [digit^{1 p. 65}] (degrees for temp. sensors). **Default** 0.5.

201 *AS.LL.* Alarm 5 Lower Limit

Lower limit selectable for the alarm 5 setpoint.

-9999..+30000 [digit^{1 p. 65}] (degrees for temp. sensors). **Default** 0.

202 *AS.uL.* Alarm 5 Upper Limit

Upper limit selectable for the alarm 5 setpoint.

-9999..+30000 [digit^{1 p. 65}] (degrees for temp. sensors). **Default** 1750.

203 *AS.rE.* Alarm 5 Reset

Alarm 5 contact reset type.

R. RES. Automatic reset (**Default**)

M. RES. Manual reset (manual reset by keyboard or by digital input)

M.RES.5. Stored manual reset (keeps the output status also after a power failure)

204 *ASSE.* Alarm 5 State Error

Alarm 5 output status in case of error.

If the alarm output is digital (SSR):

oFF Digital output OFF. **Default**

oN Digital output ON.

If the alarm output is 0-10V:

0V 0 V. **Default**

10V 10 V.

If the alarm output is 0-20 mA or 4-20 mA:

0mA 0 mA. **Default**

20mA 20 mA.

4mA 4 mA.

21.5mA 21.5 mA.

205 *rES.* Reserved

Reserved parameter

206 *AS.dE.* Alarm 5 Delay

Alarm 5 Delay.

-3600..+3600 seconds. **Default:** 0.

Negative value: delay when exit alarm status.

Positive value: delay when enter alarm status

207 *ASS.P.* Alarm 5 Setpoint Protection

Allows or not to change the alarm 5 setpoint.

FPEE Editable by the user (**Default**)

Lock Protected

HidE Protected and not visualized

208 *AS.Lb.* Alarm 5 Label

Selects the message to be visualized in case of alarm 5 intervention

0 Disabled. **Default** 0.

1-20 Message 1..20 (see customizable messages table)

209÷212 Reserved Parameters - Group K

Reserved parameters - Group K

GROUP M - d. i. 1 - Digital input 1

231	d.i.1.F.	Digital Input 1 Function
		Digital input 1 functioning.
	d.i.5Rb.	Disabled (Default)
	2E. 5M.	2 Setpoints Switch
	2E.5M.i.	2 Setpoints Switch Impulsive
	3E.5M.i.	3 Setpoints Switch Impulsive
	4E.5M.i.	4 Setpoints Switch Impulsive
	5E./5E.	Start / Stop
	RuN	Run
	MoLd	Lock conversion (stop all conversions and display values)
	EuME	Performing manual tune
	Ru.MR.i.	Automatic / Manual Impulse (if enabled on parameter 48 or 67)
	Ru.MR.c.	Automatic / Manual Contact (if enabled on parameter 48 or 67)
	RcE.tY.	Action Type. Cooling regulat. if D.I. is active, otherwise heating reg.
	R.i. 0	Analogue Input 0. Set AI to zero
	M. RES.	Manual reset. Reset the outputs if selected as manual reset.
	E.1.RuN	Timer 1 run. The timer 1 count with activated D.I.
	E.1. 5.E.	Timer 1 Start End. D.I. starts and stops the timer 1(impulsive)
	E.1.5E.R.	Timer 1 Start. D.I. starts the timer 1(impulsive)
	E.1.END	Timer 1 End. D.I. stops the timer 1(impulsive)
	E.2.RuN	Timer 2 run. The timer 2 count with activated D.I.
	E.2. 5.E.	Timer 2 Start End. D.I. starts and stops the timer 2(impulsive)
	E.2.5E.R.	Timer 2 Start. D.I. starts the timer 2(impulsive)
	E.2.END	Timer 2 End. D.I. stops the timer 2(impulsive)
	Lo.cFG.	Lock configuration and setpoints.
	uP.kEY	Simulates the functioning of up key.
	dowN.k.	Simulates the functioning of down key.
	Fnc. k.	Simulates the functioning of fnc key.
	SEt. k.	Simulates the functioning of set key.
	REM.S.E.	Remote setpoint enabling. Enables Remote setpoint with activated D.I. Local setpoint with deactivated D.I. (remote setpoint must be enabled on parameter 56 rEn.S.)

232 d.i.1.c. Digital Input 1 Contact

		Defines the resting contact of the digital input 1.
	N.oPEN	Normally open (Default)
	N.cLoS.	Normally closed

233 d.i.1.P. Digital Input 1 Process (only on UR48483A / 4A)

		Select the size related to the digital input 1.
	R.i.N.1	Value read on input AI1. (Default)
	R.i.N.2	Value read on input AI2.
	MERh	Arithmetic average of the value read on inputs AI1 and AI2 $[(AI1-AI2)/2]$.
	d.i.FF.	Difference of the values read on inputs AI1 and AI2 $(AI1-AI2)$.
	Rb.d.F.	Module of the difference of the values read on inputs AI1 and AI2 $(AI1-AI2)$.
	SuM	Sum of values read on inputs AI1 and AI2 $(AI1+AI2)$.

234 d.i.1.r. Digital Input 1 Reference Command

		Defines the resting contact of the digital input 1.
	cMd. 1	Command 1 (Default)
	cMd. 2	Command 2
	cMd.1.2	Command 1 and 2

235÷238 Reserved Parameters - Group M

Reserved parameters - Group M

GROUP N - d. i. 2 - Digital input 2

239	d.i.2.F.	Digital Input 2 Function
		Digital input 2 functioning.
	d.i.5Rb.	Disabled (Default)
	2E. 5M.	2 Setpoints Switch
	2E.5M.i.	2 Setpoints Switch Impulsive
	3E.5M.i.	3 Setpoints Switch Impulsive
	4E.5M.i.	4 Setpoints Switch Impulsive
	5E./5E.	Start / Stop
	RuN	Run
	MoLd	Lock conversion (stop all conversions and display values)
	EuME	Performing manual tune
	Ru.MR.i.	Automatic / Manual Impulse (if enabled on parameter 48 or 67)
	Ru.MR.c.	Automatic / Manual Contact (if enabled on parameter 48 or 67)
	RcE.tY.	Action Type. Cooling regulation if D.I. is active, otherwise heating reg.
	R.i. 0	Analogue Input 0. Set AI to zero
	M. RES.	Manual reset. Reset the outputs if selected as manual reset.
	E.1.RuN	Timer 1 run. The timer 1 count with activated D.I.
	E.1. 5.E.	Timer 1 Start End. D.I. starts and stops the timer 1(impulsive)
	E.1.5E.R.	Timer 1 Start. D.I. starts the timer 1(impulsive)
	E.1.END	Timer 1 End. D.I. stops the timer 1(impulsive)
	E.2.RuN	Timer 2 run. The timer 2 count with activated D.I.
	E.2. 5.E.	Timer 2 Start End. D.I. starts and stops the timer 2(impulsive)
	E.2.5E.R.	Timer 2 Start. D.I. starts the timer 2(impulsive)
	E.2.END	Timer 2 End. D.I. stops the timer 2(impulsive)
	Lo.cFG.	Lock configuration and setpoints.
	uP.kEY	Simulates the functioning of up key.
	dowN.k.	Simulates the functioning of down key.
	Fnc. k.	Simulates the functioning of fnc key.
	SEt. k.	Simulates the functioning of set key.
	REM.S.E.	Remote setpoint enabling. Enables Remote setpoint with activated D.I. Local setpoint with deactivated D.I. (remote setpoint must be enabled on parameter 56 rEn.S.)

240 d.i.2.c. Digital Input 2 Contact

		Defines the resting contact of the digital input 2.
	N.oPEN	Normally open (Default)
	N.cLoS.	Normally closed

241 d.i.2.P. Digital Input 2 Process (only on UR48483A / 4A)

		Select the size related to the digital input 2.
	R.i.N.1	Value read on input AI1. (Default)
	R.i.N.2	Value read on input AI2.
	MERh	Arithmetic average of the value read on inputs AI1 and AI2 $[(AI1-AI2)/2]$.
	d.i.FF.	Difference of the values read on inputs AI1 and AI2 $(AI1-AI2)$.
	Rb.d.F.	Module of the difference of the values read on inputs AI1 and AI2 $(AI1-AI2)$.
	SuM	Sum of values read on inputs AI1 and AI2 $(AI1+AI2)$.

242 d.i.2.r. Digital Input 2 Reference Command

		Defines the resting contact of the digital input 2.
	cMd. 1	Command 1 (Default)
	cMd. 2	Command 2
	cMd.1.2	Command 1 and 2

243÷246 Reserved Parameters - Group N

Reserved parameters - Group N

GROUP O - d. i. 3 - Digital input 3

247 d. i. 3.F. Digital Input 3 Function

	Digital input 3 functioning.
d.i.5Rb.	Disabled (Default)
2E. 5M.	2 Setpoints Switch
2E.5M.i.	2 Setpoints Switch Impulsive
3E.5M.i.	3 Setpoints Switch Impulsive
4E.5M.i.	4 Setpoints Switch Impulsive
5E./5E.	Start / Stop
RuN	Run
MoLd	Lock conversion (stop all conversions and display values)
EuME	Performing manual tune
Ru.MR.i.	Automatic / Manual Impulse (if enabled on parameter 48 or 67)
Ru.MR.c.	Automatic / Manual Contact (if enabled on parameter 48 or 67)
RcE.EY.	Action Type. Cooling regulation if D.I. is active, otherwise heating reg.
R.i. 0	Analogue Input 0. Set AI to zero
M. RES.	Manual reset. Reset the outputs if selected as manual reset.
E.1.RuN	Timer 1 run. The timer 1 count with activated D.I.
E.1. 5.E.	Timer 1 Start End. D.I. starts and stops the timer 1(impulsive)
E.1.5E.R.	Timer 1 Start. D.I. starts the timer 1(impulsive)
E.1.END	Timer 1 End. D.I. stops the timer 1(impulsive)
E.2.RuN	Timer 2 run. The timer 2 count with activated D.I.
E.2. 5.E.	Timer 2 Start End. D.I. starts and stops the timer 2(impulsive)
E.2.5E.R.	Timer 2 Start. D.I. starts the timer 2(impulsive)
E.2.END	Timer 2 End. D.I. stops the timer 2(impulsive)
Lo.cFG.	Lock configuration and setpoints.
uP.KEY	Simulates the functioning of up key.
doWn.K.	Simulates the functioning of down key.
Fnc. K.	Simulates the functioning of fnc key.
SEt. K.	Simulates the functioning of set key.
REM.S.E.	Remote setpoint enabling. Enables Remote setpoint with activated D.I. Local setpoint with deactivated D.I. (remote setpoint must be enabled on parameter 56 rEn.5.)

248 d. i. 3.c. Digital Input 3 Contact

	Defines the resting contact of the digital input 3.
N.oPEN	Normally open (Default)
N.cLoS.	Normally closed

249 d. i. 3.P. Digital Input 3 Process (only on UR48483A / 4A)

	Select the size related to the digital input 3.
R.i.N.1	Value read on input AI1. (Default)
R.i.N.2	Value read on input AI2.
MEAN	Arithmetic average of the value read on inputs AI1 and AI2 $[(AI1-AI2)/2]$.
d.FF.	Difference of the values read on inputs AI1 and AI2 $(AI1-AI2)$.
Rb.d.F.	Module of the difference of the values read on inputs AI1 and AI2 $(AI1-AI2)$.
Sum	Sum of values read on inputs AI1 and AI2 $(AI1+AI2)$.

250 d. i. 3.r. Digital Input 3 Reference Command

	Defines the reference command for the digital input 3 functions.
cMd. 1	Command 1 (Default)
cMd. 2	Command 2
cMd.1.2	Command 1 and 2

251÷254 Reserved Parameters - Group O

Reserved parameters - Group O

GROUP P - d. i. 4 - Digital input 4

255 d. i. 4.F. Digital Input 4 Function

	Digital input 4 functioning.
d.i.5Rb.	Disabled (Default)
2E. 5M.	2 Setpoints Switch
2E.5M.i.	2 Setpoints Switch Impulsive
3E.5M.i.	3 Setpoints Switch Impulsive
4E.5M.i.	4 Setpoints Switch Impulsive
5E./5E.	Start / Stop
RuN	Run
MoLd	Lock conversion (stop all conversions and display values)
EuME	Performing manual tune
Ru.MR.i.	Automatic / Manual Impulse (if enabled on parameter 48 or 67)
Ru.MR.c.	Automatic / Manual Contact (if enabled on parameter 48 or 67)
RcE.EY.	Action Type. Cooling regulation if D.I. is active, otherwise heating reg.
R.i. 0	Analogue Input 0. Set AI to zero
M. RES.	Manual reset. Reset the outputs if selected as manual reset.
E.1.RuN	Timer 1 run. The timer 1 count with activated D.I.
E.1. 5.E.	Timer 1 Start End. D.I. starts and stops the timer 1(impulsive)
E.1.5E.R.	Timer 1 Start. D.I. starts the timer 1(impulsive)
E.1.END	Timer 1 End. D.I. stops the timer 1(impulsive)
E.2.RuN	Timer 2 run. The timer 2 count with activated D.I.
E.2. 5.E.	Timer 2 Start End. D.I. starts and stops the timer 2(impulsive)
E.2.5E.R.	Timer 2 Start. D.I. starts the timer 2(impulsive)
E.2.END	Timer 2 End. D.I. stops the timer 2(impulsive)
Lo.cFG.	Lock configuration and setpoints.
uP.KEY	Simulates the functioning of up key.
doWn.K.	Simulates the functioning of down key.
Fnc. K.	Simulates the functioning of fnc key.
SEt. K.	Simulates the functioning of set key.
REM.S.E.	Remote setpoint enabling. Enables Remote setpoint with activated D.I. Local setpoint with deactivated D.I. (remote setpoint must be enabled on parameter 56 rEn.5.)

256 d. i. 4.c. Digital Input 4 Contact

	Defines the resting contact of the digital input 4.
N.oPEN	Normally open (Default)
N.cLoS.	Normally closed

257 d. i. 4.P. Digital Input 4 Process (only on UR48483A / 4A)

	Select the size related to the digital input 4.
R.i.N.1	Value read on input AI1. (Default)
R.i.N.2	Value read on input AI2.
MEAN	Arithmetic average of the value read on inputs AI1 and AI2 $[(AI1-AI2)/2]$.
d.FF.	Difference of the values read on inputs AI1 and AI2 $(AI1-AI2)$.
Rb.d.F.	Module of the difference of the values read on inputs AI1 and AI2 $(AI1-AI2)$.
Sum	Sum of values read on inputs AI1 and AI2 $(AI1+AI2)$.

258 d. i. 4.r. Digital Input 4 Reference Command

	Defines the reference command for the digital input 4 functions.
cMd. 1	Command 1 (Default)
cMd. 2	Command 2
cMd.1.2	Command 1 and 2

259÷262 Reserved Parameters - Group P

Reserved parameters - Group P

GROUP Q - *5F.E.5* - Soft-start and mini cycle

263 *Pr.cY.* Pre-programmed Cycle

Enables special functionings.

d1SRb. Disabled (**Default**)

ENRb. Enabled (all remote setpoint functions are inhibited)

264 *SS.tY.* Soft-Start Type

Enables and selects the soft-start type

d1SRb. Disabled (**Default**)

GRd. Gradient

PERc. Percentage (only with pre-programmed cycle disabled)

265 *SS.r.c.* Soft-Start Reference Command *(only on UR48483A / 4A)*

Defines the reference command for the Soft-Start and the pre-programmed cycle.

cMd. 1 Command 1 (**Default**)

cMd. 2 Command 2

cMd. 1.2 Command 1 and 2

266 *SS.Gr.* Soft-Start Gradient

Rising/falling gradient for soft-start and pre-programmed cycle.

0..20000 Digit/ora (gradi.decimo/ora se temperatura). (**Default**: 100.0)

267 *SS.PE.* Soft-Start Percentage

Output percentage during soft-start function.

0..100%. (**Default**: 50%)

268 *SS.tH.* Soft-Start Threshold

Threshold under which the soft-start percentage function is activated, at starting.

-9999...30000 [digit^{1 p.65}] (degrees.tenths for temp. sensors) (**Default**: 1000)

269 *SS.t.t.* Soft-Start Time

Max. Softstart duration: if the process will not reach the threshold selected on par. *SS.tH.* within the selected time, the controller starts to regulate on setpoint.

00:00 Disabled

00:01-24:00 hh:mm (**Default**: 00:15)

270 *MR.t.t.* Maintenance Time

Maintenance time for pre-programmed cycle.

00:00-24:00 hh.mm (**Default**: 00:00)

271 *FAL.Gr.* Falling Gradient

Falling gradient for pre-programmed cycle.

0 Disabled (**Default**)

1..10000 Digit/ora^{1 p.65} (degrees.tenths/hour if temperature)

272÷276 Reserved Parameters - Group Q

Reserved parameters - Group Q

GROUP R - *d1SP.* - Display

277 *v.FLE* Visualization Filter

d1SRb. Disabled

Pt.cHF Pitchfork filter (**Default**)

F1.oRd. First Order

F1.oR.P. First Order with Pitchfork

2.SR.M. 2 Samples Mean

....
...n Samples Mean

10.SR.M. 10 Samples Mean

278 *v.i.d.2* Visualization Display 2

Selects visualization on display 2.

c.1.SP.V Command 1 setpoint (**Default**)

ou.PE.1 Percentage of command output 1

R.i.N.1 Value read on input AI1.

R.i.N.2 Value read on input AI2.

MERN Arithmetic average of the value read on inputs AI1 and AI2 $[(AI1-AI2)/2]$.

d1FF. Difference of the values read on inputs AI1 and AI2 $(AI1-AI2)$.

Rb.d1F. Module of the difference of the values read on inputs AI1 and AI2 $(|AI1-AI2|)$.

Sum Sum of values read on inputs AI1 and AI2 $(AI1+AI2)$.

c.2.SP.V Command 2 setpoint

ou.PE.2 Percentage of command output 2

AMPPEP. Ampere from current transformer

279 *tNo.d.* Timeout Display

Determines the display timeout

d1SRb. Disabled. Display always ON (**Default**)

15 S 15 seconds

1 M.N 1 minute

5 M.N 5 minutes

10 M.N 10 minutes

30 M.N 30 minutes

1 H 1 hour

280 *tNo.S.* Timeout Selection

Selects which display is switched off when Display Timeout expires

d1SP.1 Display 1

d1SP.2 Display 2 (**Default**)

dSP.1.2 Display 1 and 2

d.1.2.Ld. Display 1, 2 and led

281 *v.PP.c.* User Menu Pre-Programmed Cycle

Allows to modify rising/falling gradient and retention time from the user menu, in pre-programmed cycle functioning. To access parameter modification, press **SET**.

d1SRb. Disabled (**Default**)

P.r.S.GR. Only rising gradient

MR.t.t. Only retention time

P.r.G.M.t. Rising gradient and retention time

FAL.GR Only falling gradient

P.r.FR.G. Rising and falling gradient

FR.G.M.t. Falling gradient and retention time

P.r.F.G.M.t. Rising gradient, retention time and falling gradient

282 *v.o.u.t.* **Voltage Output**

Selects the voltage on the sensors power terminals and of the digital outputs (SSR).

12 V 12 volt (**Default**)
24 V 24 volt

283 *s.c.l.t.* **Scrolling Time**

Select the duration for the visualization of the user menu data, before returning to the default page.

3 S 3 seconds
5 S 5 seconds (**Default**)
10 S 10 seconds
30 S 30 seconds
1 M.N 1 minutes
5 M.N 5 minutes
10 M.N 10 minutes
MAN.Sc. Manual scroll

284 *d.s.p.f.* **Display Special Functions**

d.s.f.b. Special functions disabled
S.M.R.P. Shows the setpoint on display 1 and the process on display 2 (only if Par. 278 *u.i.d.2* set on *c.i.s.p.v.*)

285 *n.f.c.l.* **NFC Lock**

d.s.f.b. NFC lock disabled: NFC accessible.
E.N.R.b. NFC lock enabled: NFC not accessible.

286 **Reserved Parameters - Group R**

Reserved parameters - Group R

GROUP S - *c.t.* - Current transformer**287** *c.t.f.* **Current Transformer Function**

Enables the C.T. input and selects the net frequency

d.s.f.b. Disabilitato (**Default**)
50 HZ 50 Hz
60 HZ 60 Hz

288 *c.t.u.* **Current Transformer Value**

Selects the amperometric transformer full-scale

1..200 Ampere (**Default: 50**)

289 *H.b.A.c.* **Heater Break Alarm Reference Command**

Defines the reference command for the heater break alarm and the overcurrent alarm.

c.m.d. 1 Command 1 (**Default**)
c.m.d. 2 Command 2

290 *H.b.A.t.* **Heater Break Alarm Threshold**

Heater Break Alarm activation threshold

0 Alarm disabled. (**Default:**)
0.1-200.0 Ampere.

291 *o.c.u.t.* **Overcurrent Alarm Threshold**

Overcurrent alarm threshold.

0 Alarm disabled. (**Default**)
0.1-200.0 Ampere

292 *H.b.A.d.* **Heater Break Alarm Delay**

Heater Break Alarm and overcurrent alarm activation delay.

00:00-60:00 mm:ss (**Default:** 01:00)

293÷297 **Reserved Parameters - Group S**

Reserved parameters - Group S

GROUP T - *R.d. 1* - Retransmission 1**298** *r.t.r.1* **Retransmission 1**

Retransmission for output. Parameters 300 and 301 define lower and upper limit of the operating scale.

d.s.f.b. Disabled (**Default**)
c.1.s.p.v. Command 1 setpoint
R.L. 1 Alarm 1 setpoint
R.L. 2 Alarm 2 setpoint
M.d.b.u.5 Retransmits the value written on word 1241
R.i.N.1 Value read on input AI1
R.i.N.2 Value read on input AI2
M.E.A.R. Arithmetic average of the value read on inputs AI1 and AI2 $[(AI1+AI2)/2]$
d.i.f.f. Difference of the values read on inputs AI1 and AI2 $(AI1-AI2)$
R.b.d.i.f. Module of the difference of the values read on inputs AI1 and AI2 $(|AI1-AI2|)$
S.u.M. Sum of values read on inputs AI1 and AI2 $(AI1+AI2)$
c.2.s.p.v. Command 2 setpoint
R.M.P.E.R. Ampere from current transformer

299 *r.t.t.y.* **Retransmission 1 Type**

Selects the retransmission type for AO1

0.10 V Output 0...10 V.
4.20 mA Output 4...20 mA. **Default**

300 *r.l.l.l.* **Retransmission 1 Lower Limit**

Retransmission 1 lower limit range (value related to 10 V or 0/4 mA).
-9999.+30000 [digit^{1 p.65}] (degrees if temperature), **Default:** 0.

301 *r.l.u.l.* **Retransmission 1 Upper Limit**

Retransmission 1 upper limit range 2 (value related to 10 V or 20 mA).
-9999.+30000 [digit^{1 p.65}] (degrees if temperature), **Default:** 1000.

302 *r.i.s.e.* **Retransmission 1 State Error**

Determines retransmission 1 value in case of error or anomaly

If the retransmission output is 0-10V:

0 V 0 V. **Default**
10 V 10 V.

If the retransmission output is 0-20 mA or 4-20 mA:

0 mA 0 mA. **Default**
4 mA 4 mA.
20 mA 20 mA.
21.5 mA 21.5 mA.

303÷307 **Reserved Parameters - Group T**

Reserved parameters - Group T

GROUP U - *R.O. 2* - Retransmission 2

308 *rEt2* Retransmission 2

Retransmission for output AO2. Parameters 310 and 311 define lower and upper limit of the operating scale.

<i>dSRb.</i>	Disabled (Default)
<i>c.1.SPv</i>	Command 1 setpoint
<i>AL. 1</i>	Alarm 1 setpoint
<i>AL. 2</i>	Alarm 2 setpoint
<i>Mod.buS</i>	Retransmits the value written on word 1242
<i>R.in.1</i>	Value read on input AI1
<i>R.in.2</i>	Value read on input AI2
<i>MERH</i>	Arithmetic average of the value read on inputs AI1 and AI2 $[(AI1+AI2)/2]$
<i>dIFF.</i>	Difference of the values read on inputs AI1 and AI2 $(AI1-AI2)$
<i>Ab.dIF.</i>	Module of the difference of the values read on inputs AI1 and AI2 $(AI1-AI2)$
<i>Sum</i>	Sum of values read on inputs AI1 and AI2 $(AI1+AI2)$
<i>c.2.SPv</i>	Command 2 setpoint
<i>AMPER.</i>	Ampere from current transformer

309 *r2tY.* Retransmission 2 Type

Selects the retransmission type for AO2

<i>0.10 V</i>	Output 0...10 V.
<i>4.20mA</i>	Output 4...20 mA. Default

310 *r2.LL.* Retransmission 2 Lower Limit

Retransmission 2 lower limit range (value related to 10 V or 0/4 mA).
-9999..+30000 [digit^{1 p.65}] (degrees if temperature), **Default**: 0.

311 *r2.uL.* Retransmission 2 Upper Limit

Retransmission 2 upper limit range 2 (value related to 10 V or 20 mA).
-9999..+30000 [digit^{1 p.65}] (degrees if temperature), **Default**: 1000.

312 *r2SE.* Retransmission 2 State Error

Determines retransmission 2 value in case of error or anomaly.

If the retransmission output is 0-10V:

<i>0 V</i>	0 V. Default
<i>10 V</i>	10 V.

If the retransmission output is 0-20 mA or 4-20 mA:

<i>0 mA</i>	0 mA. Default
<i>4 mA</i>	4 mA.
<i>20 mA</i>	20 mA.
<i>21.5 mA</i>	21.5 mA.

313÷317 Reserved Parameters - Group U

Reserved parameters - Group U

GROUP V - *SEr.* - Seriale

318 *SLAd.* Slave Address

Selects slave address for serial communication.
1...254. **Default**: 247.

319 *bd.rE.* Baud Rate

Selects baudrate for serial communication

<i>1.2 K</i>	1200 bit/s
<i>2.4 K</i>	2400 bit/s
<i>4.8 K</i>	4800 bit/s
<i>9.6 K</i>	9600 bit/s
<i>19.2 K</i>	19200 bit/s (Default)
<i>28.8 K</i>	28800 bit/s
<i>38.4 K</i>	38400 bit/s
<i>57.6 K</i>	57600 bit/s
<i>115.2K</i>	115200 bit/s

320 *S.P.P.* Serial Port Parameters

Selects the format for the modbus RTU serial communication.

<i>B-N-1</i>	8 bit, no parity, 1 stop bit (Default)
<i>B-E-1</i>	8 bit, even parity, 1 stop bit
<i>B-o-1</i>	8 bit, odd parity, 1 stop bit
<i>B-N-2</i>	8 bit, no parity, 2 stop bit
<i>B-E-2</i>	8 bit, even parity, 2 stop bit
<i>B-o-2</i>	8 bit, odd parity, 2 stop bit

321 *SE.dE.* Serial Delay

Selects serial delay
0...100 ms. **Default**: 5 ms.

322 *oFFL.* Off Line

Selects the off-line time. If there is no serial communication during the selected time, the controller switches-off the command output.

0	Offline disabled (Default)
0.1-600.0	tenths of second.

323÷327 Reserved Parameters - Group V

Reserved parameters - Group V

GROUP W - ETC - Timer

328 ETC.1 Timer 1

Enabling Timer 1
 d1SRb. Disabled (Default)
 ENRb. Enabled
 EN.5tR. Enabled and active at start

329 E.b.t.1 Time Base Timer 1

Selects time base for timer 1
 MM.55 minutes.seconds (Default)
 HH.MM hours.minutes

330 A.t.N.1 Action Timer 1

Select the type of the action executed by the timer 1 to be related to an alarm..
 5tARPt Start. Active during timer counting (Default)
 ENd End. Active at timer expiry
 WARPt Warning. Active 5" before the timer expiry

331 ETC.2 Timer 2

Enabling Timer 2
 d1SRb. Disabled (Default)
 ENRb. Enabled
 EN.5tR. Enabled and active at start

332 E.b.t.2 Time Base Timer 2

Selects time base for timer 2
 MM.55 minutes.seconds (Default)
 HH.MM hours.minutes

333 A.t.N.2 Action Timer 2

Select the type of the action executed by the timer 2 to be related to an alarm..
 5tARPt Start. Active during timer counting (Default)
 ENd End. Active at timer expiry.
 WARPt Warning. Active 5" before the timer expiry.

334 ETC.5 Timers Sequence

Select the correlation between the two timers.
 SINGL. Singles. Timers work independently (Default)
 SEQUE. Sequential. When timer 1 ends, timer 2 starts.
 LOOP. Loop. When a timer ends, another starts.

335÷339 Reserved Parameters - Group W

Reserved parameters - Group W

14 Alarm Intervention Modes

14.a Absolute or threshold alarm active over (par. 123 AL.IF. = Ab.uPA)

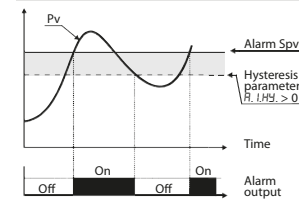

Absolute alarm.
 Hysteresis value greater than "0" (Par. 128 R.I.HI > 0).

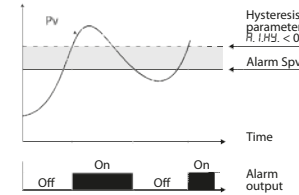

Absolute alarm.
 Hysteresis value less than "0" (Par. 128 R.I.HI > 0).

14.b Absolute or threshold alarm referred to command setpoint active over (par. 123 AL.IF. = Ab.c.uPA)

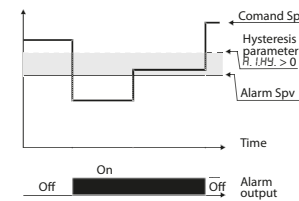

Absolute alarm referred to command setpoint. Hysteresis value greater than "0" (Par. 128 R.I.HI > 0).

14.c Band alarm (par. 123 AL.IF. = bAnd)

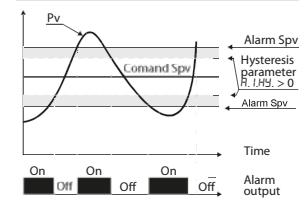

Band alarm hysteresis value greater than "0" (Par. 128 R.I.HI > 0).

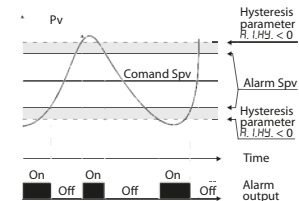

Band alarm hysteresis value less than "0" (Par. 128 R.I.HI < 0).

14.d Upper deviation alarm (par. 123 $R.L.I.F. = uP.dE_u$)

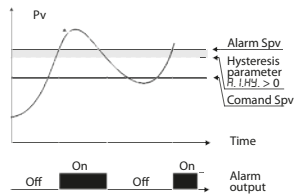

Upper deviation alarm value of alarm setpoint greater than "0" and hysteresis value greater than "0" (Par.128 $R.I.H.Y. > 0$).

With hysteresis value less than "0" ($R.I.H.Y. < 0$) the dotted line moves under the alarm setpoint.

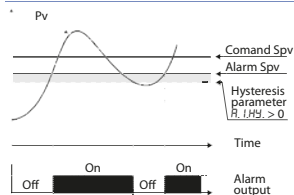

Upper deviation alarm value of alarm setpoint less than "0" and hysteresis value greater than "0" (Par.128 $R.I.H.Y. > 0$).

With hysteresis value less than "0" ($R.I.H.Y. < 0$) the dotted line moves under the alarm setpoint.

14.e Lower deviation alarm (par. 123 $R.L.I.F. = Ld.dE_u$)

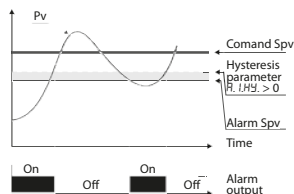

Lower deviation alarm value of alarm setpoint greater than "0" and hysteresis value greater than "0" (Par.128 $R.I.H.Y. > 0$).

With hysteresis value less than "0" ($R.I.H.Y. < 0$) the dotted line moves under the alarm setpoint.

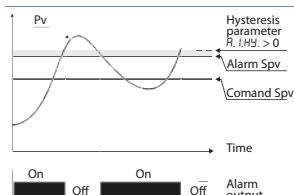

Lower deviation alarm value of alarm setpoint less than "0" and hysteresis value greater than "0" (Par.128 $R.I.H.Y. > 0$).

With hysteresis value less than "0" ($R.I.H.Y. < 0$) the dotted line moves under the alarm setpoint.

15 Table of Anomaly Signals

If installation malfunctions, the controller switches off the regulation output and reports the anomaly noticed. For example, controller will report failure of a connected thermocouple visualizing E-05 (flashing) flashing on display.

For other signals see table below.

	Cause	What to do
E-02 SYSTEM Error	Cold junction temperature sensor failure or environment temperature out of range	Call assistance
E-04 EEPROM Error	Incorrect configuration data. Possible loss of instrument calibration	Verify that configuration parameters are correct.
E-05 Probe 1 Error	Sensor connected to AI1 broken or temperature out of range	Control connection with probes and their integrity.
E-06 Probe 2 Error	Sensor connected to AI2 broken or temperature out of range	Control connection with probes and their integrity.
E-08 SYSTEM Error	Missing calibration	Call assistance
E-10 A.in.2 disabled	Analogue input 2 disabled but used during configuration.	Enable $A.in.2$ or disable it during configuration.
E-80 rfid Error	Tag rfid malfunctioning	Call assistance

Notes / Updates

- 1 Display of decimal point depends on setting of parameter SEN . and parameter $d.P$.
- 2 On activation, the output is inhibited if the controller is in alarm mode. Activates only if alarm condition reappears, after that it was restored.

Table of configuration parameters

GROUP A - <i>A. in. 1</i> - Analogue input 1		
1	<i>SEn.1</i>	Sensor AI1 27
2	<i>d.P. 1</i>	Decimal Point 1 27
3	<i>dEGr.</i>	Degree 27
4	<i>LL.i.1</i>	Lower Linear Input AI1 27
5	<i>uL.i.1</i>	Upper Linear Input AI1 27
6	<i>P.wA.1</i>	Potentiometer Value AI1 27
7	<i>i.o.L.1</i>	Linear Input over Limits AI1 28
8	<i>o.cA.1</i>	Offset Calibration AI1 28
9	<i>G.cA.1</i>	Gain Calibration AI1 28
10	<i>LtC.1</i>	Latch-On AI1 28
11	<i>c.FL.1</i>	Conversion Filter AI1 28
12	<i>c.Fr.1</i>	Conversion Frequency AI1 28
13÷17		Reserved Parameters - Group A 28
GROUP B - <i>A. in. 2</i> - Analogue input 2		
18	<i>SEn.2</i>	Sensor AI2 29
19	<i>d.P. 2</i>	Decimal Point 2 29
20	<i>rES.</i>	Reserved 29
21	<i>LL.i.2</i>	Lower Linear Input AI2 29
22	<i>uL.i.2</i>	Upper Linear Input AI2 29
23	<i>P.wA.2</i>	Potentiometer Value AI2 29
24	<i>i.o.L.2</i>	Linear Input over Limits AI2 29
25	<i>o.cA.2</i>	Offset Calibration AI2 30
26	<i>G.cA.2</i>	Gain Calibration AI2 30
27	<i>LtC.2</i>	Latch-On AI2 30
28	<i>c.FL.2</i>	Conversion Filter AI2 30
29	<i>c.Fr.2</i>	Conversion Frequency AI2 30
30÷34		Reserved Parameters - Group B 30
GROUP C - <i>cPd. 1</i> - Outputs and regulation Process 1		
35	<i>c.ov.1</i>	Command Output 1 31
36	<i>c.Pr.1</i>	Command Process 1 (only on UR48483A / 4A) 31
37	<i>rES.</i>	Reserved 31
38	<i>Act.1</i>	Action type 1 31
39	<i>c.HY.1</i>	Command Hysteresis 1 31
40	<i>LL.S.1</i>	Lower Limit Setpoint 1 32
41	<i>uL.S.1</i>	Upper Limit Setpoint 1 32
42	<i>c.rE.1</i>	Command Reset 1 32
43	<i>c.S.E.1</i>	Command State Error 1 32
44	<i>c.Ld.1</i>	Command Led 1 32
45	<i>c.dE.1</i>	Command Delay 1 32
46	<i>c.S.P.1</i>	Command Setpoint Protection 1 32
47	<i>vA.t.1</i>	Valve Time 1 32
48	<i>A.MA.1</i>	Automatic / Manual 1 33
49÷53		Reserved Parameters - Group C 33
GROUP D - <i>cPd. 2</i> - Outputs and regulation Process 2		
54	<i>c.ov.2</i>	Command Output 2 (only on UR48483A / 4A) 33
55	<i>c.Pr.2</i>	Command Process 2 (only on UR48483A / 4A) 33

56	<i>rES.</i>	Remote Setpoint (only on UR48483A / 4A) 33
57	<i>Act.2</i>	Action type 2 33
58	<i>c.HY.2</i>	Command Hysteresis 2 33
59	<i>LL.S.2</i>	Lower Limit Setpoint 2 33
60	<i>uL.S.2</i>	Upper Limit Setpoint 2 34
61	<i>c.rE.2</i>	Command Reset 2 34
62	<i>c.S.E.2</i>	Command State Error 2 34
63	<i>c.Ld.2</i>	Command Led 2 34
64	<i>c.dE.2</i>	Command Delay 2 34
65	<i>c.S.P.2</i>	Command Setpoint Protection 2 34
66	<i>vA.t.2</i>	Valve Time 2 34
67	<i>A.MA.2</i>	Automatic / Manual 2 35
68÷72		Reserved Parameters - Group D 35
GROUP E - <i>rEG. 1</i> - Autotuning and PID 1		
73	<i>tun.1</i>	Tune 1 35
74	<i>S.d.t.1</i>	Setpoint Deviation Tune 1 35
75	<i>P.b. 1</i>	Proportional Band 1 35
76	<i>i.t. 1</i>	Integral Time 1 35
77	<i>d.t. 1</i>	Derivative Time 1 35
78	<i>d.b. 1</i>	Dead Band 1 35
79	<i>P.b.c.1</i>	Proportional Band Centered 1 35
80	<i>o.o.S.1</i>	Off Over Setpoint 1 35
81	<i>o.d.t.1</i>	Off Deviation Threshold 1 36
82	<i>c.t. 1</i>	Cycle Time 1 36
83	<i>co.F.1</i>	Cooling Fluid 1 36
84	<i>P.b.M.1</i>	Proportional Band Multiplier 1 36
85	<i>o.d.b.1</i>	Overlap / Dead Band 1 36
86	<i>c.c.t.1</i>	Cooling Cycle Time 1 36
87	<i>LL.P.1</i>	Lower Limit Output Percentage 1 36
88	<i>uL.P.1</i>	Upper Limit Output Percentage 1 36
89	<i>MG.t.1</i>	Max Gap Tune 1 36
90	<i>Mn.P.1</i>	Minimum Proportional Band 1 36
91	<i>MA.P.1</i>	Maximum Proportional Band 1 36
92	<i>Mn.i.1</i>	Minimum Integral Time 1 37
93	<i>o.c.L.1</i>	Overshoot Control Level 1 37
94÷97		Reserved Parameters - Group E 37
GROUP F - <i>rEG. 2</i> - Autotuning and PID 2		
98	<i>tun.2</i>	Tune 2 37
99	<i>S.d.t.2</i>	Setpoint Deviation Tune 2 37
100	<i>P.b. 2</i>	Proportional Band 2 37
101	<i>i.t. 2</i>	Integral Time 2 37
102	<i>d.t. 2</i>	Derivative Time 2 37
103	<i>d.b. 2</i>	Dead Band 2 37
104	<i>P.b.c.2</i>	Proportional Band Centered 2 38
105	<i>o.o.S.2</i>	Off Over Setpoint 2 38
106	<i>o.d.t.2</i>	Off Deviation Threshold 2 38
107	<i>c.t. 2</i>	Cycle Time 2 38
108	<i>co.F.2</i>	Cooling Fluid 2 38
109	<i>P.b.M.2</i>	Proportional Band Multiplier 2 38

110	<i>o.d.b.2</i>	Overlap / Dead Band 2	38
111	<i>c.c.t.2</i>	Cooling Cycle Time 2	38
112	<i>l.l.P.2</i>	Lower Limit Output Percentage 2	38
113	<i>u.l.P.2</i>	Upper Limit Output Percentage 2	38
114	<i>g.g.t.2</i>	Max Gap Tune 2	39
115	<i>pn.P.2</i>	Minimum Proportional Band 2	39
116	<i>pr.P.2</i>	Maximum Proportional Band 2	39
117	<i>ni.i.2</i>	Minimum Integral Time 2	39
118	<i>o.c.L.2</i>	Overshoot Control Level 2	39
119÷122		Reserved Parameters - Group F	39

GROUP G - *AL. 1* - ALARM 1

123	<i>AL.1.F.</i>	Alarm 1 Function	40
124	<i>AL.1.Pr.</i>	Alarm 1 Process (only on UR48483A / 4A)	40
125	<i>AL.1.r.c.</i>	Alarm 1 Reference Command	40
126	<i>AL.1.S.o.</i>	Alarm 1 State Output	40
127	<i>rES.</i>	Reserved	40
128	<i>AL.1.HY.</i>	Alarm 1 Hysteresis	40
129	<i>AL.1.L.L.</i>	Alarm 1 Lower Limit	41
130	<i>AL.1.U.L.</i>	Alarm 1 Upper Limit	41
131	<i>AL.1.rE.</i>	Alarm 1 Reset	41
132	<i>AL.1.S.E.</i>	Alarm 1 State Error	41
133	<i>AL.1.L.d.</i>	Alarm 1 Led	41
134	<i>AL.1.dE.</i>	Alarm 1 Delay	41
135	<i>AL.1.S.P.</i>	Alarm 1 Setpoint Protection	41
136	<i>AL.1.L.b.</i>	Alarm 1 Label	41
137÷140		Reserved Parameters - Group G	41

GRUPPO H - *AL. 2* - Alarm 2

141	<i>AL.2.F.</i>	Alarm 2 Function	42
142	<i>AL.2.Pr.</i>	Alarm 2 Process (only on UR48483A / 4A)	42
143	<i>AL.2.r.c.</i>	Alarm 2 Reference Command	42
144	<i>AL.2.S.o.</i>	Alarm 2 State Output	42
145	<i>rES.</i>	Reserved	42
146	<i>AL.2.HY.</i>	Alarm 2 Hysteresis	42
147	<i>AL.2.L.L.</i>	Alarm 2 Lower Limit	43
148	<i>AL.2.U.L.</i>	Alarm 2 Upper Limit	43
149	<i>AL.2.rE.</i>	Alarm 2 Reset	43
150	<i>AL.2.S.E.</i>	Alarm 2 State Error	43
151	<i>AL.2.L.d.</i>	Alarm 2 Led	43
152	<i>AL.2.dE.</i>	Alarm 2 Delay	43
153	<i>AL.2.S.P.</i>	Alarm 2 Setpoint Protection	43
154	<i>AL.2.L.b.</i>	Alarm 2 Label	43
155÷158		Reserved Parameters - Group H	43

GROUP I - *AL. 3* - Alarm 3

159	<i>AL.3.F.</i>	Alarm 3 Function	44
160	<i>AL.3.Pr.</i>	Alarm 3 Process (only on UR48483A / 4A)	44
161	<i>AL.3.r.c.</i>	Alarm 3 Reference Command	44
162	<i>AL.3.S.o.</i>	Alarm 3 State Output	44
163	<i>AL.3.o.t.</i>	Alarm 3 Output Type	44

164	<i>AL.3.HY.</i>	Alarm 3 Hysteresis	45
165	<i>AL.3.L.L.</i>	Alarm 3 Lower Limit	45
166	<i>AL.3.U.L.</i>	Alarm 3 Upper Limit	45
167	<i>AL.3.rE.</i>	Alarm 3 Reset	45
168	<i>AL.3.S.E.</i>	Alarm 3 State Error	45
169	<i>AL.3.L.d.</i>	Alarm 3 Led	45
170	<i>AL.3.dE.</i>	Alarm 3 Delay	45
171	<i>AL.3.S.P.</i>	Alarm 3 Setpoint Protection	45
172	<i>AL.3.L.b.</i>	Alarm 3 Label	45
173÷176		Reserved Parameters - Group I	45

GROUP J - *AL. 4* - Alarm 4

177	<i>AL.4.F.</i>	Alarm 4 Function	46
178	<i>AL.4.Pr.</i>	Alarm 4 Process (only on UR48483A / 4A)	46
179	<i>AL.4.r.c.</i>	Alarm 4 Reference Command	46
180	<i>AL.4.S.o.</i>	Alarm 4 State Output	46
181	<i>AL.4.o.t.</i>	Alarm 4 Output Type	47
182	<i>AL.4.HY.</i>	Alarm 4 Hysteresis	47
183	<i>AL.4.L.L.</i>	Alarm 4 Lower Limit	47
184	<i>AL.4.U.L.</i>	Alarm 4 Upper Limit	47
185	<i>AL.4.rE.</i>	Alarm 4 Reset	47
186	<i>AL.4.S.E.</i>	Alarm 4 State Error	47
187	<i>rES.</i>	Reserved	47
188	<i>AL.4.dE.</i>	Alarm 4 Delay	47
189	<i>AL.4.S.P.</i>	Alarm 4 Setpoint Protection	47
190	<i>AL.4.L.b.</i>	Alarm 4 Label	47
191÷194		Reserved Parameters - Group J	47

GROUP K - *AL. 5* - Alarm 5 (only on -23ABC-T)

195	<i>AL.5.F.</i>	Alarm 5 Function	48
196	<i>AL.5.Pr.</i>	Alarm 5 Process (only on UR48483A / 4A)	48
197	<i>AL.5.r.c.</i>	Alarm 5 Reference Command	48
198	<i>AL.5.S.o.</i>	Alarm 5 State Output	48
199	<i>AL.5.o.t.</i>	Alarm 5 Output Type	48
200	<i>AL.5.HY.</i>	Alarm 5 Hysteresis	49
201	<i>AL.5.L.L.</i>	Alarm 5 Lower Limit	49
202	<i>AL.5.U.L.</i>	Alarm 5 Upper Limit	49
203	<i>AL.5.rE.</i>	Alarm 5 Reset	49
204	<i>AL.5.S.E.</i>	Alarm 5 State Error	49
205	<i>rES.</i>	Reserved	49
206	<i>AL.5.dE.</i>	Alarm 5 Delay	49
207	<i>AL.5.S.P.</i>	Alarm 5 Setpoint Protection	49
208	<i>AL.5.L.b.</i>	Alarm 5 Label	49
209÷212		Reserved Parameters - Group K	49

GROUP L - *AL. 6* - Alarm 6 (only on -23ABC-T)

213	<i>AL.6.F.</i>	Alarm 6 Function	50
214	<i>AL.6.Pr.</i>	Alarm 6 Process (only on UR48483A / 4A)	50
215	<i>AL.6.r.c.</i>	Alarm 6 Reference Command	50
216	<i>AL.6.S.o.</i>	Alarm 6 State Output	50
217	<i>AL.6.o.t.</i>	Alarm 6 Output Type	51

218	<i>A.6.HY.</i>	Alarm 6 Hysteresis	51
219	<i>A.6.L.L.</i>	Alarm 6 Lower Limit	51
220	<i>A.6.U.L.</i>	Alarm 6 Upper Limit	51
221	<i>A.6.r.E.</i>	Alarm 6 Reset	51
222	<i>A.6.S.E.</i>	Alarm 6 State Error	51
223	<i>r.E.S.</i>	Reserved	51
224	<i>A.6.d.E.</i>	Alarm 6 Delay	51
225	<i>A.6.S.P.</i>	Alarm 6 Setpoint Protection	51
226	<i>A.6.L.b.</i>	Alarm 6 Label	51
227÷230		Reserved Parameters - Group L	51
GROUP M - d. i. 1 - Digital input 1			
231	<i>d. i. 1.F.</i>	Digital Input 1 Function	52
232	<i>d. i. 1.c.</i>	Digital Input 1 Contact	52
233	<i>d. i. 1.P.</i>	Digital Input 1 Process (only on UR48483A / 4A)	52
234	<i>d. i. 1.r.</i>	Digital Input 1 Reference Command	52
235÷238		Reserved Parameters - Group M	52
GROUP N - d. i. 2 - Digital input 2			
239	<i>d. i. 2.F.</i>	Digital Input 2 Function	53
240	<i>d. i. 2.c.</i>	Digital Input 2 Contact	53
241	<i>d. i. 2.P.</i>	Digital Input 2 Process (only on UR48483A / 4A)	53
242	<i>d. i. 2.r.</i>	Digital Input 2 Reference Command	53
243÷246		Reserved Parameters - Group N	53
GROUP O - d. i. 3 - Digital input 3			
247	<i>d. i. 3.F.</i>	Digital Input 3 Function	54
248	<i>d. i. 3.c.</i>	Digital Input 3 Contact	54
249	<i>d. i. 3.P.</i>	Digital Input 3 Process (only on UR48483A / 4A)	54
250	<i>d. i. 3.r.</i>	Digital Input 3 Reference Command	54
251÷254		Reserved Parameters - Group O	54
GROUP P - d. i. 4 - Digital input 4			
255	<i>d. i. 4.F.</i>	Digital Input 4 Function	55
256	<i>d. i. 4.c.</i>	Digital Input 4 Contact	55
257	<i>d. i. 4.P.</i>	Digital Input 4 Process (only on UR48483A / 4A)	55
258	<i>d. i. 4.r.</i>	Digital Input 4 Reference Command	55
259÷262		Reserved Parameters - Group P	55
GROUP Q - S.F.t.S - Soft-start and mini cycle			
263	<i>P.r.c.H.</i>	Pre-programmed Cycle	56
264	<i>S.S.t.H.</i>	Soft-Start Type	56
265	<i>S.S.r.c.</i>	Soft-Start Reference Command (only on AUR48483A / 4A)	56
266	<i>S.S.G.r.</i>	Soft-Start Gradient	56
267	<i>S.S.P.E.</i>	Soft-Start Percentage	56
268	<i>S.S.t.H.</i>	Soft-Start Threshold	56
269	<i>S.S.t.i.</i>	Soft-Start Time	56
270	<i>M.A.t.i.</i>	Maintenance Time	56
271	<i>F.A.G.r.</i>	Falling Gradient	56
272÷276		Reserved Parameters - Group Q	56
GROUP R - d. i.S.P. - Display			
277	<i>u.F.t.</i>	Visualization Filter	57

278	<i>u.i.d.2</i>	Visualization Display 2	57
279	<i>t.o.d.</i>	Timeout Display	57
280	<i>t.o.S.</i>	Timeout Selection	57
281	<i>u.M.P.c.</i>	User Menu Pre-Programmed Cycle	57
282	<i>u.o.u.t.</i>	Voltage Output	58
283	<i>S.c.l.t.</i>	Scrolling Time	58
284	<i>d.S.P.F.</i>	Display Special Functions	58
285	<i>n.F.c.L.</i>	NFC Lock	58
286		Reserved Parameters - Group R	58
GROUP S - c.t. - Current transformer			
287	<i>c.t.F.</i>	Current Transformer Function	58
288	<i>c.t.v.</i>	Current Transformer Value	58
289	<i>H.b.A.r.</i>	Heater Break Alarm Reference Command	58
290	<i>H.b.A.t.</i>	Heater Break Alarm Threshold	58
291	<i>o.c.u.t.</i>	Overcurrent Alarm Threshold	58
292	<i>H.b.A.d.</i>	Heater Break Alarm Delay	59
293÷297		Reserved Parameters - Group S	59
GROUP T - R.A. 1 - Retransmission 1			
298	<i>r.t.1</i>	Retransmission 1	59
299	<i>r.t.t.y.</i>	Retransmission 1 Type	59
300	<i>r.l.L.L.</i>	Retransmission 1 Lower Limit	59
301	<i>r.u.L.L.</i>	Retransmission 1 Upper Limit	59
302	<i>r.S.E.</i>	Retransmission 1 State Error	59
303÷307		Reserved Parameters - Group T	59
GROUP U - R.A. 2 - Retransmission 2			
308	<i>r.t.2</i>	Retransmission 2	60
309	<i>r.t.t.y.</i>	Retransmission 2 Type	60
310	<i>r.l.L.L.</i>	Retransmission 2 Lower Limit	60
311	<i>r.u.L.L.</i>	Retransmission 2 Upper Limit	60
312	<i>r.S.E.</i>	Retransmission 2 State Error	60
313÷317		Reserved Parameters - Group U	60
GROUP V - S.E.r. - Seriale			
318	<i>S.L.A.d.</i>	Slave Address	61
319	<i>b.d.r.t.</i>	Baud Rate	61
320	<i>S.P.P.</i>	Serial Port Parameters	61
321	<i>S.E.d.E.</i>	Serial Delay	61
322	<i>o.F.F.L.</i>	Off Line	61
323÷327		Reserved Parameters - Group V	61
GROUP W - t.i.m.r - Timer			
328	<i>t.i.m.r.1</i>	Timer 1	62
329	<i>t.b.t.1</i>	Time Base Timer 1	62
330	<i>A.t.i.1</i>	Action Timer 1	62
331	<i>t.i.m.r.2</i>	Timer 2	62
332	<i>t.b.t.2</i>	Time Base Timer 2	62
333	<i>A.t.i.2</i>	Action Timer 2	62
334	<i>t.i.m.r.S.</i>	Timers Sequence	62
335÷339		Reserved Parameters - Group W	62