

THIS COPY IS PROVIDED ON A RESTRICTED BASIS AND IS NOT TO BE USED IN ANY WAY DETRIMENTAL TO THE INTERESTS OF PANDUIT CORP.

NOTES:
1. DIMENSIONS IN [] ARE
IN MILLIMETERS.

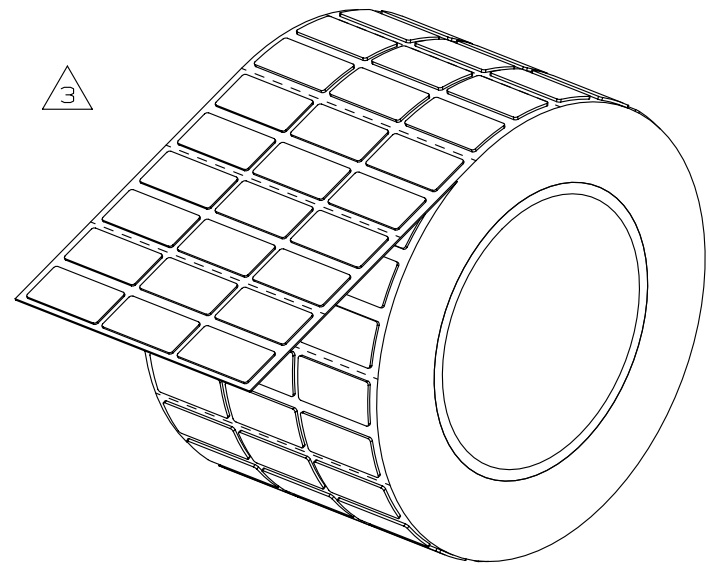

PANDUIT PART NO.	MATERIAL	FACE COLOR	PKG. QTY.	THICKNESS	PRODUCT TYPE
C100X050A0T	GMH3	BLACK	500	.030 +/- .010	POLYESTER/ FOAM COMPONENT LABEL
C100X050A8T		YELLOW			
C100X050AMT		SILVER			
C100X050APT	GMH3-W	WHITE			
C100X050AST	GMH3	GREEN			
C100X050AUT		ORANGE			
C100X050AWT		RED			

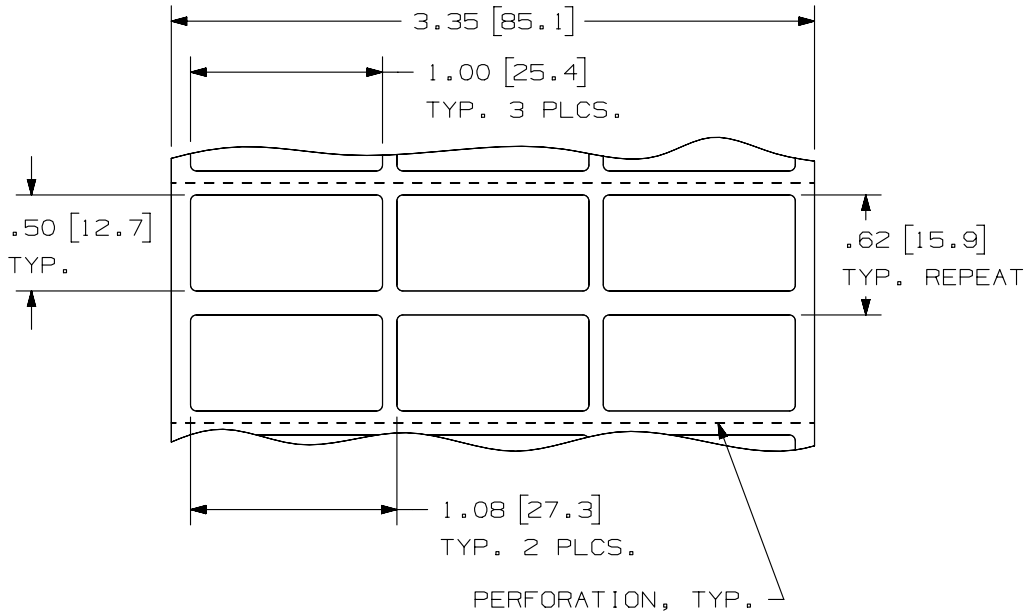

REV	DATE	BY	CHK	APR	DESCRIPTION	ECN
3	1/10/13	RVU	DAPE	SEWH	ADD material column and ISO view. Update part numbers sequence list.	GAECN00515
2	5/3/10	RVU	DAPE		TOL. SHOULD BE .12, .062, NOT .1, .050. ADD NEW PN: C100X050AUT.	6348
1	12/18/08	RVU	DAPE		REMOVE "REPEAT" FROM THE LABEL SIZE.	5592
0	9/5/08	RVU	DAPE	PTR	DRAWING RELEASE.	5537

TITLE						
RAISED PANEL PUSH BUTTON LABELS C100X050A*T CUSTOMER DRAWING						
ITEM REVISION NAME						
100491BP/05						
DATASET FILE NAME						
100491BP-DC-C10729/05D						
UNLESS OTHERWISE SPECIFIED, DIMENSIONAL TOLERANCES ARE: IN [mm]						
.x ± .12 [3.05] .xxx ± .025 [.635]						
.xx ± .062 [1.57] ANGLES ±						
THIRD ANGLE PROJECTION						
DRAWING NUMBER:						
C10729						
DRAWN BY	DATE	CHK	SCALE	SHT 1 OF 1		
RVU	9/5/08	SCWE	NTS	A		



SEE TABLE

DRAWING NUMBER:
C10729

SHT 1 OF 1

A

D10100DA/12