

TABLE 1

番号 No.	部品 PART	材質 MATERIAL	
①	ハウジング HOUSING	ナイロン, UL94-V0, 色 : 自然色(ベージュ) / 黒 NYLON (PA), UL94-V0, COLOR : NATURAL(BEIGE) / BLACK	
②	ターミナル TERMINAL	材料 MATERIAL	黄銅 BRASS
		下地めっき UNDER PLATING	ニッケルめっき 1.27マイクロメートル以上 NICKEL PLATING 1.27micro-meter MIN
		接点部、テール CONTACT AND TAIL	無光沢錫めっき 2.54マイクロメートル以上 MATTE TIN PLATING 2.54 micro-meter MIN

注記

NOTE

- ①. 材質および仕上げ(めっき仕様) : TABLE 1 参照  
MATERIAL AND FINISH: SEE TABLE 1
- ②. 製品仕様書 : PS-87437-001  
PRODUCT SPECIFICATION : PS-87437-001
- ③. 製品取扱説明書 : 874370000-AS  
APPLICATION SPECIFICATION : 874370000-AS
- ④. テール平坦度 : 0.1以下  
TAIL COPLANARITY TO BE 0.1 MAX.
- ⑤. 嵌合相手 : 87439シリーズ (リセプタクルハウジング), 87421シリーズ (圧着端子)  
MATE WITH 87439 SERIES (RECEPTACLE HOUSING)  
AND 87421 SERIES (CRIMP TERMINAL).
- ⑥. 本製品は錫めっき品である。金めっき品は202706シリーズを参照。  
THIS PRODUCT IS TIN PLATING.  
FOR GOLD PLATING, REFER TO 202706 SERIES.

21.2	22.8	21.0	23.8	87438-15*1	15
19.7	21.3	19.5	22.3	87438-14*1	14
18.2	19.8	18.0	20.8	87438-13*1	13
16.7	18.3	16.5	19.3	87438-12*1	12
15.2	16.8	15.0	17.8	87438-11*1	11
13.7	15.3	13.5	16.3	87438-10*1	10
12.2	13.8	12.0	14.8	87438-09*1	9
10.7	12.3	10.5	13.3	87438-08*1	8
9.2	10.8	9.0	11.8	87438-07*1	7
7.7	9.3	7.5	10.3	87438-06*1	6
6.2	7.8	6.0	8.8	87438-05*1	5
4.7	6.3	4.5	7.3	87438-04*1	4
3.2	4.8	3.0	5.8	87438-03*1	3
1.7	3.3	1.5	4.3	87438-02*1	2
D	C	B	A	ヘッダー番号 HEADER NO.	極数 CIRCUIT SIZE

THIS DRAWING CONTAINS INFORMATION THAT IS PROPRIETARY TO MOLEX ELECTRONIC TECHNOLOGIES, LLC AND SHOULD NOT BE USED WITHOUT WRITTEN PERMISSION

DIMENSION UNITS mm	SCALE NTS	CURRENT REV DESC: REVISED		<b>molex</b>			
GENERAL TOLERANCES (UNLESS SPECIFIED)		EC NO: 699885				PICO-SPOX 1.5/WB CONN R/A HEADER ASSY (SMT TIN PLATING VERSION)	
ANGULAR TOL	± 3.0°	DRWN: RTANAKA02		2022/03/14			
4 PLACES	± 0.2	CHK'D: SAKIYAMA		2022/09/30			
3 PLACES	± 0.2	APPR: AIDA		2022/09/30			
2 PLACES	± 0.2	INITIAL REVISION:		DOCUMENT NUMBER			
1 PLACE	± 0.2	DRWN: RTANAKA02		874380231-SD			
0 PLACES	± 0.2	APPR: SAKIYAMA		PSD 000 C			
DRAFT WHERE APPLICABLE MUST REMAIN WITHIN DIMENSIONS		THIRD ANGLE PROJECTION	DRAWING	SERIES	MATERIAL NUMBER	CUSTOMER	SHEET NUMBER
			A3-SIZE	87438	SEE SHEET 3	GENERAL	1 OF 3

# 推奨基板レイアウト RECOMMENDED PCB LAYOUT

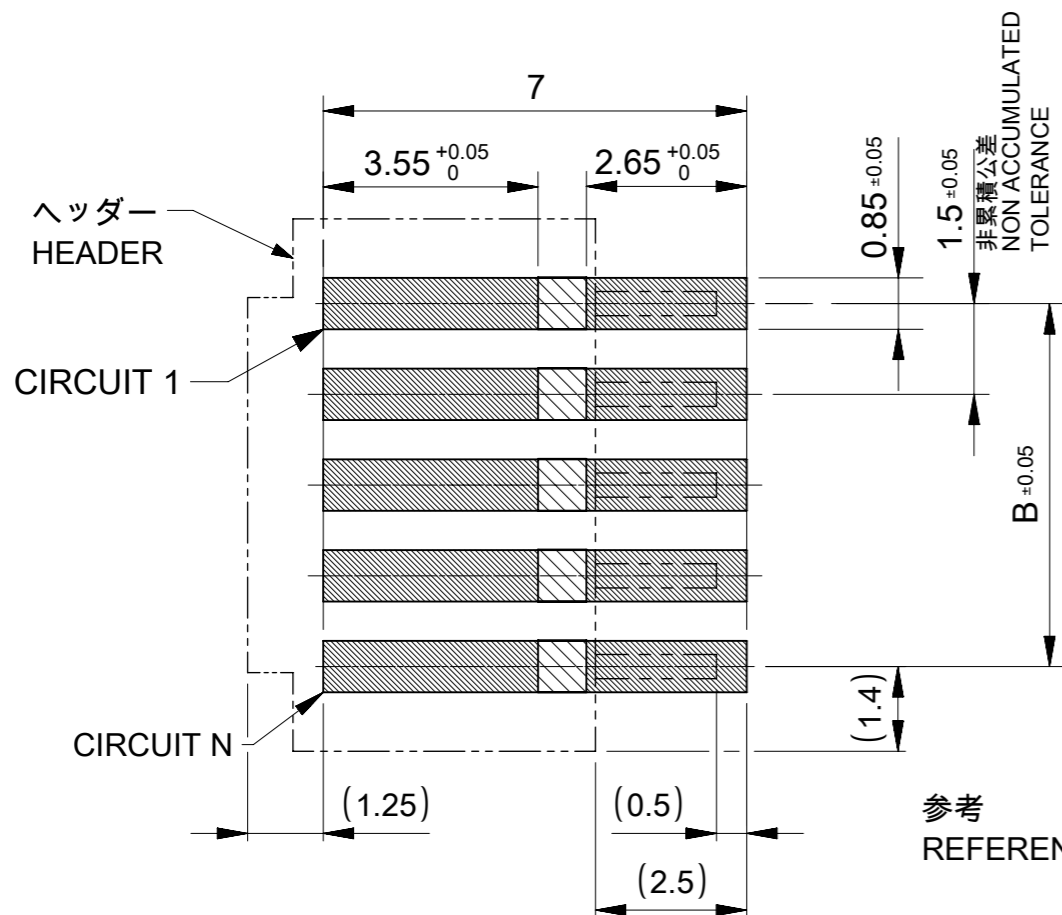

参考 : 基板厚 1.0mm  
 REFERENCE : PCB THICKNESS 1.0mm  
 メタルマスク厚 0.12mm  
 STENCIL THICKNESS 0.12mm  
 マスク開口率100%  
 APERTURE RATIO 100%.

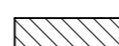
 : 半田エリア (パターンエリア)  
 SOLDER AREA (COPPER ZONE)  
 : 半田禁止エリア (パターン禁止エリア)  
 SOLDER KEEP OUT AREA (NO-COPPER ZONE)  
 半田上がりを防ぐため。  
 TO PREVENT SOLDER LIFTING.  
 レジストによって分離する場合は、パターン面よりも盛り上がらないこと。  
 IF APPLY RESIST IN THIS AREA, LEVEL AS PATTERN AREA FACE.

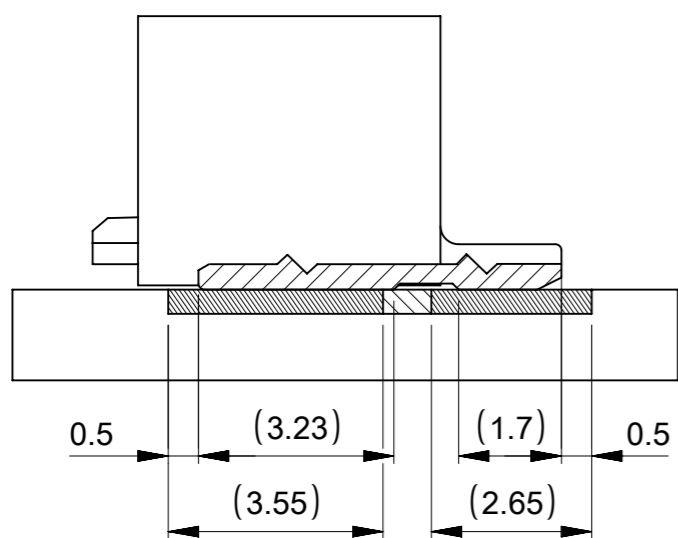

# 5 嵌合図 MATED CONNECTORS

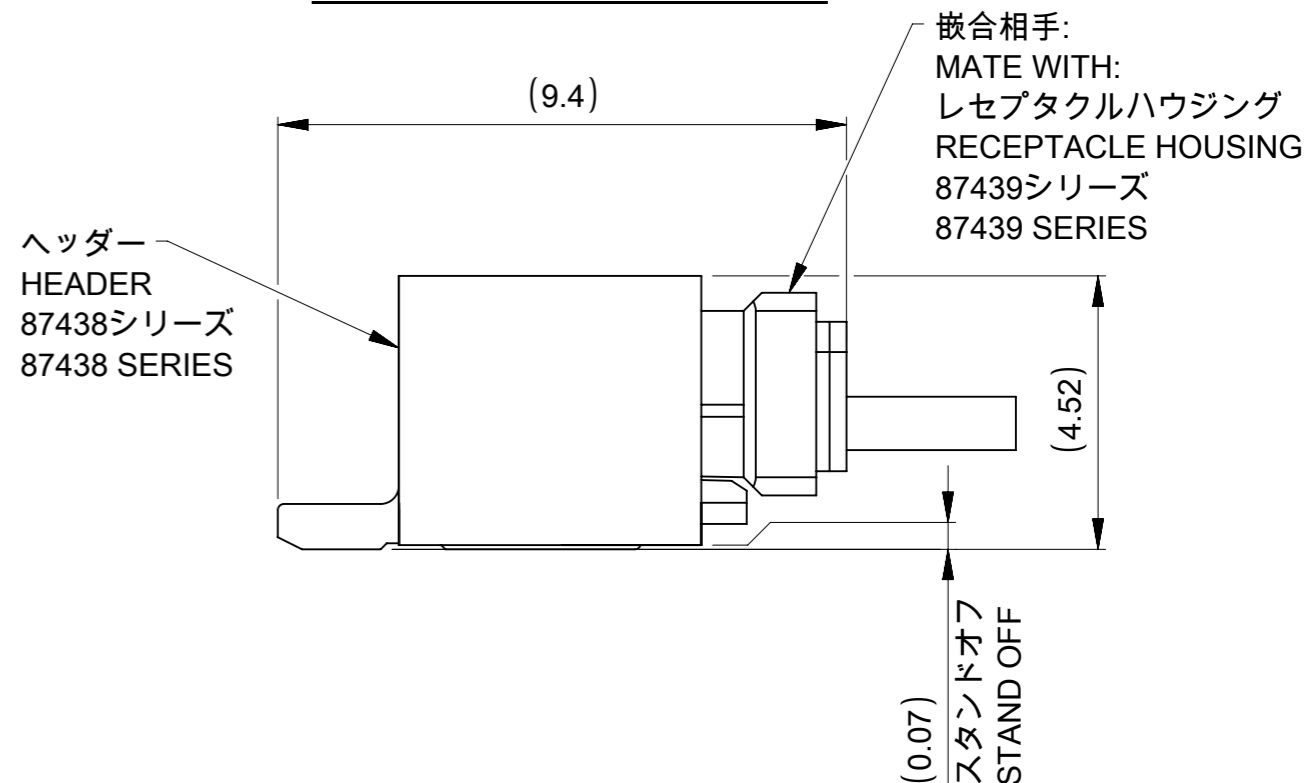

THIS DRAWING CONTAINS INFORMATION THAT IS PROPRIETARY TO MOLEX ELECTRONIC TECHNOLOGIES, LLC AND SHOULD NOT BE USED WITHOUT WRITTEN PERMISSION											
DIMENSION UNITS		SCALE		CURRENT REV DESC: REVISED				<b>molex</b>		PICO-SPOX 1.5 W/B CONN R/A HEADER ASSY (SMT TIN PLATING VERSION)	
mm		NTS									
GENERAL TOLERANCES (UNLESS SPECIFIED)										PRODUCT CUSTOMER DRAWING	
ANGULAR TOL ± 3.0°											
4 PLACES		± 0.2		EC NO: 699885		2022/03/14		DOCUMENT NUMBER		DOC TYPE DOC PART REVISION	
3 PLACES		± 0.2		DRWN: RTANAKA02		2022/09/30					
2 PLACES		± 0.2		CHK'D: SAKIYAMA		2022/09/30		874380231-SD		PSD 000 C	
1 PLACE		± 0.2		APPR: AIDA		2022/09/30		MATERIAL NUMBER		CUSTOMER	
0 PLACES		± 0.2		INITIAL REVISION:		2018/12/06		SEE SHEET 3		GENERAL	
DRAFT WHERE APPLICABLE MUST REMAIN WITHIN DIMENSIONS		THIRD ANGLE PROJECTION		DRAWING		SERIES		SHEET NUMBER		2 OF 3	
		A3-SIZE		87438							

# エンボス梱包 詳細 EMBOSSED CARRIER TAPE PACKING DETAILS

# リール 詳細 REEL DETAILS

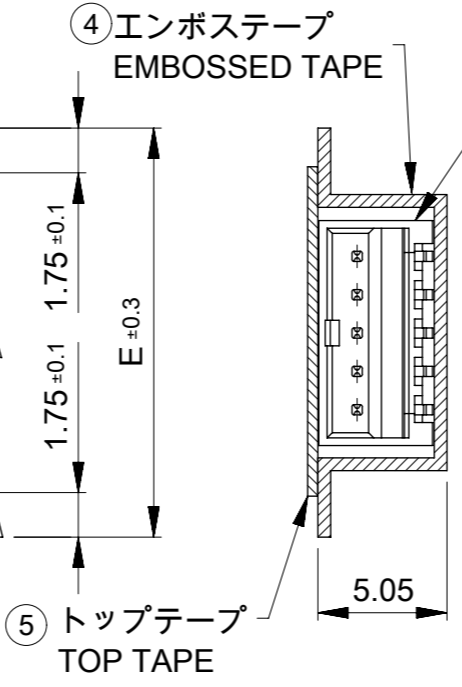
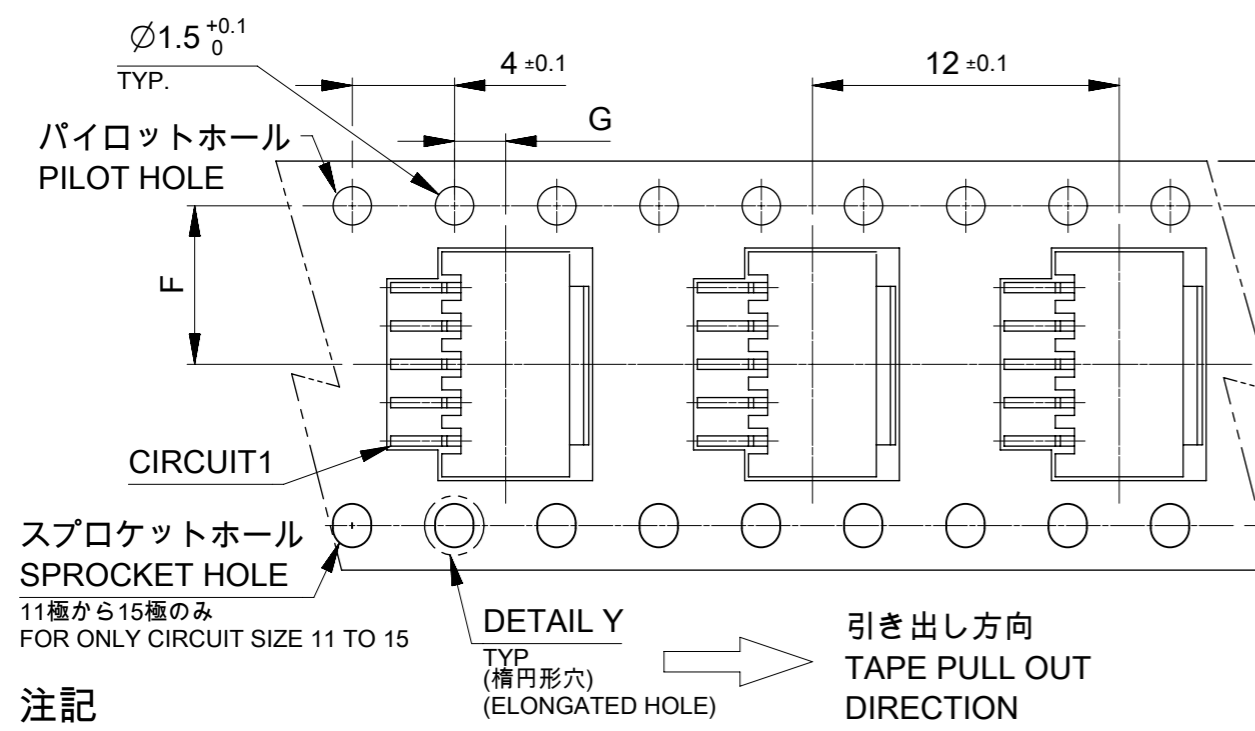

ヘッダー番号  
HEADER NO.  
87438-\*\*41 (BEIGE)  
87438-\*\*61 (BLACK)

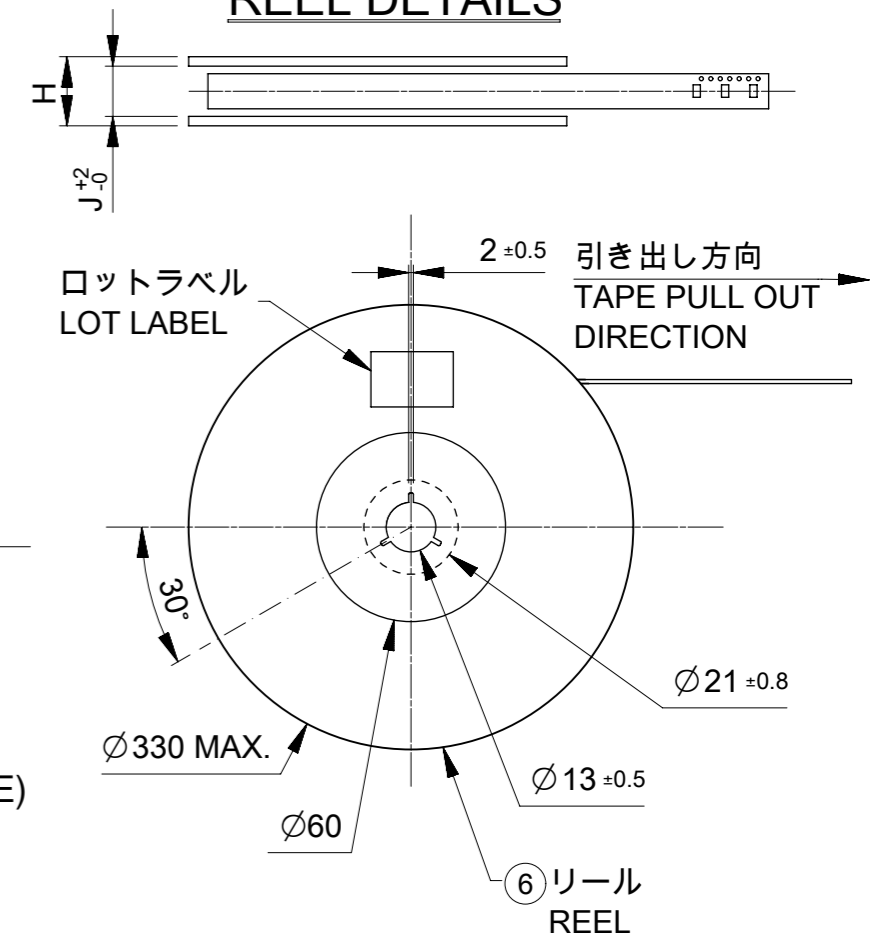
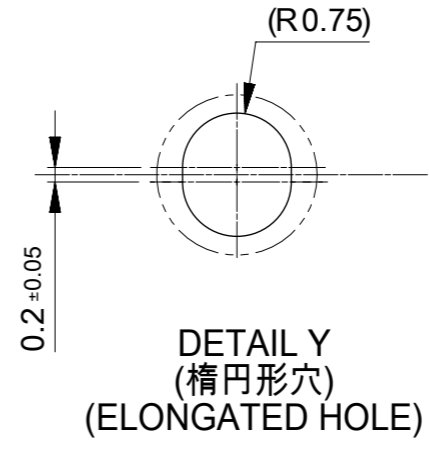

注記  
NOTE  
7. リーダー部および末端部テープ長さ  
LEADER AND TRAILER TAPE LENGTH

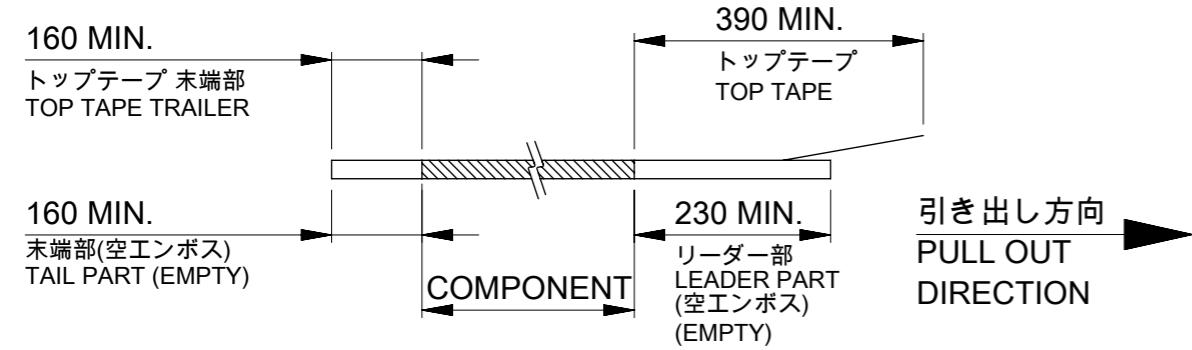

8. トップテープの剥離強度：IEC60286-3に準拠。  
PEELING OFF FORCE OF THE TOP TAPE: DEFINED IEC60286-3.  
(剥離方向は下図を参照)  
(PEELING DIRECTION AS SHOWN IN FOLLOWING FIGURE)

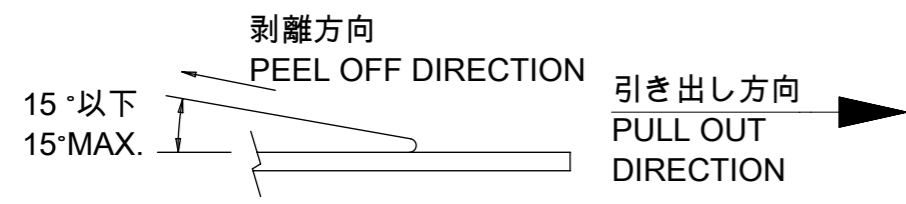

9. EIA-481に準拠する。  
PACKAGING STANDARD IS AS PER EIA-481.  
10. 梱包数量=1000個/リール  
TAPE & REEL QUANTITY=1000PCS/REEL  
11. 本製品は乾燥剤入りハイバリア梱包での納品となる。  
THIS PRODUCT IS DELIVERED IN A HIGH BARRIER PACKAGE WITH DESICCANT.  
12. 梱包仕様書：SPK-87438-001  
PACKAGING INFORMATION：SPK-87438-001

発注番号  
ORDER NUMBER  
87438- \* \* \* 3

極数 CIRCUIT SIZE	ハウジングカラー HOUSING COLOR
02 から 15 02 TO 15	4: ベージュ BEIGE
	6: 黒 BLACK

44.4	50.4	2±0.15	20.2±0.15	44	15
					14
					13
32.4	38.4		14.2±0.1	32	12
					11
					10
24.4	30.4	2±0.1	11.5±0.1	24	9
					8
					7
16.4	22.4		7.5±0.1	16	6
					5
					4
					3
					2
J	H MAX	G	F	E	極数 CIRCUIT SIZE

番号 NO.	部品 PART	材質 MATERIAL	THIS DRAWING CONTAINS INFORMATION THAT IS PROPRIETARY TO MOLEX ELECTRONIC TECHNOLOGIES, LLC AND SHOULD NOT BE USED WITHOUT WRITTEN PERMISSION		CURRENT REV DESC: REVISED			
			DIMENSION UNITS mm	SCALE NTS				
GENERAL TOLERANCES (UNLESS SPECIFIED)			EC NO: 699885		DRWN: RTANAKA02		2022/03/14	
ANGULAR TOL ± 3.0°			4 PLACES ± 0.2		CHK'D: SAKIYAMA		2022/09/30	
4 PLACES ± 0.2			3 PLACES ± 0.2		APPR: AIDA		2022/09/30	
3 PLACES ± 0.2			2 PLACES ± 0.2		INITIAL REVISION:		DOCUMENT NUMBER	
2 PLACES ± 0.2			1 PLACE ± 0.2		DRWN: RTANAKA02		874380231-SD	
1 PLACE ± 0.2			0 PLACES ± 0.2		APPR: SAKIYAMA		PSD 000 C	
0 PLACES ± 0.2			DRAFT WHERE APPLICABLE MUST REMAIN WITHIN DIMENSIONS		THIRD ANGLE PROJECTION		SERIES	
					DRAWING		MATERIAL NUMBER	
					A3-SIZE		CUSTOMER	
					87438		SHEET NUMBER	
					SEE SHEET 3		GENERAL	
							3 OF 3	