



FCIconnect.com

Copyright FCI.

List of "SFV\_\_R-1/2STE9HLF" customer document

DOCUMENT NO.	LIST
10117320(Sheet1)	DOCUMENT LIST
10117320(Sheet2)	CAT.NO.TABLE FOR 0.5mm CONTACT SPACING CONNECTOR (SFV__R-1/2ST_HLF)
10117320(Sheet3)	CONNECTOR USED FOR FPC/FPC WITH 0.5mm CONTACT SPACING (SFV__R-1ST_HLF)
10117320(Sheet4)	CONNECTOR USED FOR FPC/FPC WITH 0.5mm CONTACT SPACING (SFV__R-2ST_HLF)
10117320(Sheet5)	CAT.NO.TABLE FOR PLASTIC TAPE PACKAGED 0.5mm CONTACT SPACING CONNECTOR (SFV__R-1/2STE9HLF)
10117320(Sheet6)	PLASTIC TAPE PACKAGED 0.5mm CONTACT SPACING CONNECTOR (SFV__R-1STE9HLF)
10117320(Sheet7)	PLASTIC TAPE PACKAGED 0.5mm CONTACT SPACING CONNECTOR (SFV__R-2STE9HLF)
10117320(Sheet8)	RECOMMENDED CABLE (FPC) (SFV__R-1/2ST__LF)
10117320(Sheet9)	RECOMMENDED CABLE (FPC) (SFV__R-1/2ST__LF)
GS-12-645	SPEC.
BUM-SFV101	HANDLING PROCEDURES

mat'l. code				surface ISO 1302 <input checked="" type="checkbox"/>		tolerance ISO 406 <input checked="" type="checkbox"/> ISO 1101		projection 		product family 58EF		CODE JP		
ltr	ecn no	dr	date	tolerances unless otherwise specified						title 0.5mm SPACING FPC CONNECTOR DOCUMENT LIST (Cat. No. : SFV__R-1/2STE9HLF)				
A	J11-0042	S.W	2011-2-10	angles	linear									
				dr	<i>S. Mitchell</i>		2011-2-10				dwg no		sheet 1 of 9	size
				enrg	<i>S. Mitchell</i>		2011-2-10				10117320		A4	
				chr	<i>N. Rammedu</i>		2011-2-10				type Product Customer Drawing			
				appd	<i>M. G. G.</i>		Feb 10/11							
sheet index	revision sheet	A	A	A	A	A	A	A	A	A	A	A	A	Rev. A

form: A4

CAT. NO. & DIMENSIONS

NO. OF CONTACTS (n)	CAT. NO.	DIMENSIONS (NOTE2)			
		A ± 0.2	B ± 0.2	C ± 0.1	D ± 0.1
4	SFV4R-1/2ST__HLF	7.5	5.9	1.5	2.7
5	SFV5R-1/2ST__HLF	8.0	6.4	2.0	3.2
6	SFV6R-1/2ST__HLF	8.5	6.9	2.5	3.7
7	SFV7R-1/2ST__HLF	9.0	7.4	3.0	4.2
8	SFV8R-1/2ST__HLF	9.5	7.9	3.5	4.7
9	SFV9R-1/2ST__HLF	10.0	8.4	4.0	5.2
10	SFV10R-1/2ST__HLF	10.5	8.9	4.5	5.7
11	SFV11R-1/2ST__HLF	11.0	9.4	5.0	6.2
12	SFV12R-1/2ST__HLF	11.5	9.9	5.5	6.7
13	SFV13R-1/2ST__HLF	12.0	10.4	6.0	7.2
14	SFV14R-1/2ST__HLF	12.5	10.9	6.5	7.7
15	SFV15R-1/2ST__HLF	13.0	11.4	7.0	8.2
16	SFV16R-1/2ST__HLF	13.5	11.9	7.5	8.7
17	SFV17R-1/2ST__HLF	14.0	12.4	8.0	9.2
18	SFV18R-1/2ST__HLF	14.5	12.9	8.5	9.7
19	SFV19R-1/2ST__HLF	15.0	13.4	9.0	10.2
20	SFV20R-1/2ST__HLF	15.5	13.9	9.5	10.7
21	SFV21R-1/2ST__HLF	16.0	14.4	10.0	11.2
22	SFV22R-1/2ST__HLF	16.5	14.9	10.5	11.7
23	SFV23R-1/2ST__HLF	17.0	15.4	11.0	12.2
24	SFV24R-1/2ST__HLF	17.5	15.9	11.5	12.7
25	SFV25R-1/2ST__HLF	18.0	16.4	12.0	13.2
26	SFV26R-1/2ST__HLF	18.5	16.9	12.5	13.7
27	SFV27R-1/2ST__HLF	19.0	17.4	13.0	14.2
28	SFV28R-1/2ST__HLF	19.5	17.9	13.5	14.7
29	SFV29R-1/2ST__HLF	20.0	18.4	14.0	15.2
30	SFV30R-1/2ST__HLF	20.5	18.9	14.5	15.7
31	SFV31R-1/2ST__HLF	21.0	19.4	15.0	16.2
32	SFV32R-1/2ST__HLF	21.5	19.9	15.5	16.7
33	SFV33R-1/2ST__HLF	22.0	20.4	16.0	17.2
34	SFV34R-1/2ST__HLF	22.5	20.9	16.5	17.7
35	SFV35R-1/2ST__HLF	23.0	21.4	17.0	18.2

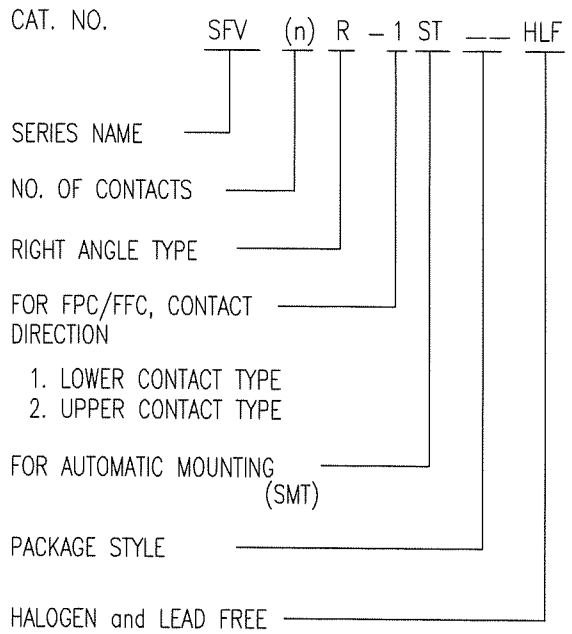

NOTES

1. THIS PRODUCT IS THE CONNECTOR USED FOR FPC AND COPES WITH AUTOMATIC MOUNTING (SMT).
2. SEE PART DRAWINGS FOR DIMENSIONS A~D.



FCIconnect.com

Copyright FCI.

mat'l. code				surface <input checked="" type="checkbox"/> ISO 1302 <input type="checkbox"/> ISO 406 <input type="checkbox"/> ISO 1101		tolerance		projection		product family 58EF		CODE JP	
ltr ecn no dr date				tolerances unless otherwise specified		mm		mm		title			
A				angles linear		mm		scale X		CAT. NO. TABLE FOR 0.5 mm CONTACT SPACING CONNECTOR (Cat. No. : SFV__R-1/2ST__HLF)			
dr				engr		chr		appd		dwg no 10117320		sheet 2 of 9 size A4	
sheet index				revision sheet		type Product Customer Drawing		Rev. A					

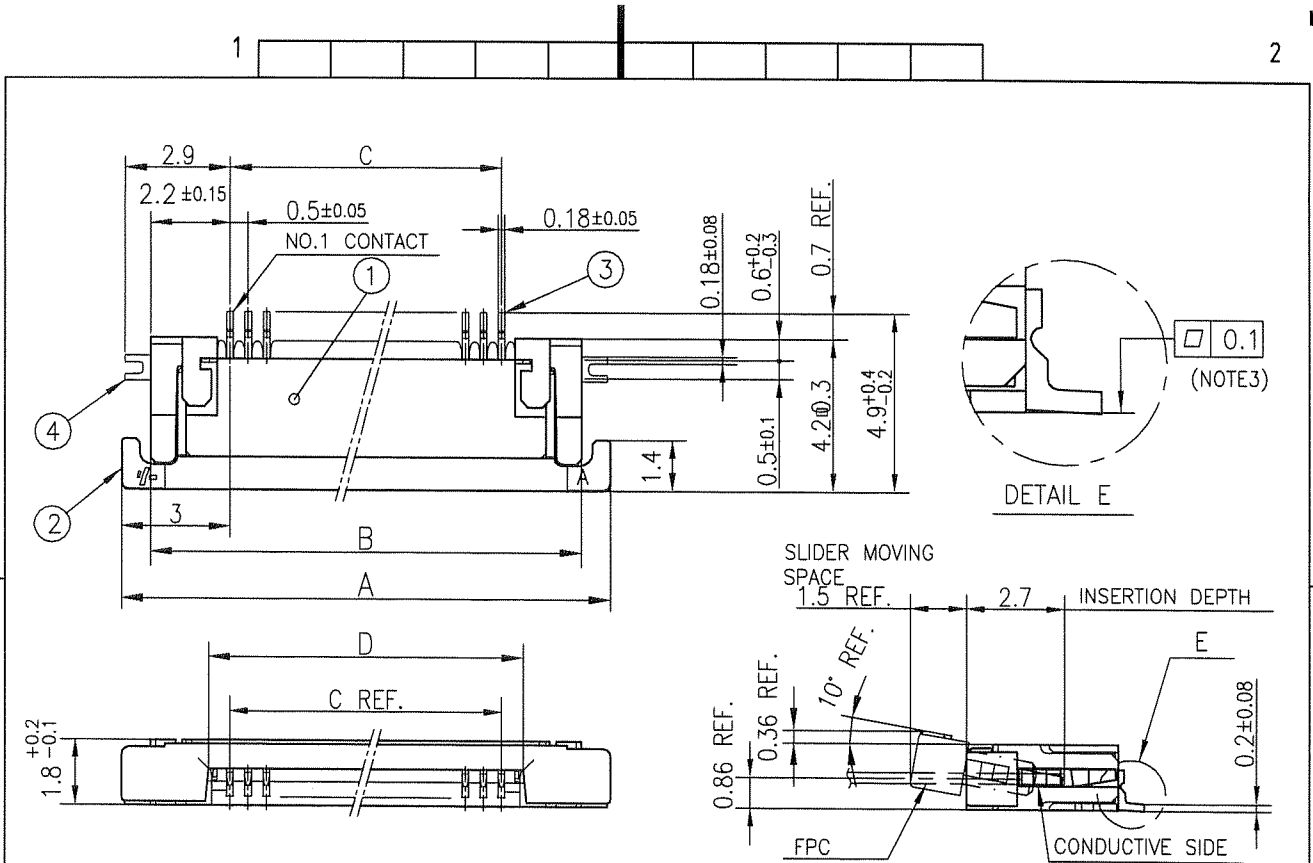

PT. NO.	PARTS NAME	MATERIAL	Q'TY	NOTE
1	HOUSING	13~35pin : LCP RESIN GLASS REINFORCED (UL94V-0)	1	COLOR : BLACK (HALOGEN FREE)
		4~12pin : POLYAMIDE RESIN GLASS REINFORCED (UL94V-0)		
2	SLIDER	PPS RESIN GLASS REINFORCED (UL94V-0)	1	COLOR : BLACK (HALOGEN FREE)
3	CONTACT	PHOSPHOR BRONZE	n	PLATING : MATTE PURE TIN Ni UNDER PLATED (LEAD FREE)
4	MOUNTING PLATE		2	

RECOMMENDED PC BOARD LAYOUT  
(COMPONENT SIDE)

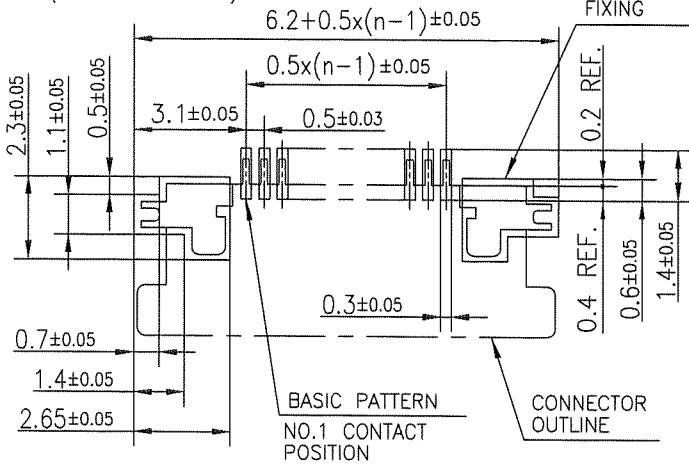

PATTERN FOR MOUNTING PLATE  
FIXING

n : NO. OF CONTACTS

NOTES

- THIS PRODUCT IS THE CONNECTOR USED FOR FPC AND COPS WITH AUTOMATIC MOUNTING (SMT).
- THIS PRODUCT IS LOWER CONTACT TYPE CONNECTOR.
- FLATNESS OF CONTACT TERMINAL AND MOUNTING PLATE MUST BE WITHIN TOLERANCE IN E PORTION DETAILED DRAWING.
- THIS PRODUCT MEETS EUROPEAN UNION DIRECTIVES AND OTHER COUNTRY REGULATIONS AS DESCRIBED IN GS-22-008.
- THE HOUSING WILL WITHSTAND EXPOSURE TO 260°C PEAK TEMPERATURE FOR 10 SECONDS IN A REFLOW SOLDERING OVEN.

mat'l. code		surface		tolerance		projection		product family		CODE	
		ISO 1302 ✓		ISO 406		mm		58EF		JP	
ltr		ecn no		dr		date		title			
A								CONNECTOR USED FOR FPC WITH 0.5 mm CONTACT SPACING (Cat No. : SFV__R-1ST__HLF)			
sheet index		revision sheet		dr		engr		dwg no		sheet 3 of 9	
				S. Watabe		2011-2-10		10117320		size A4	
				S. Watabe		2011-2-10		type		Product Customer Drawing	
				Y. Kamada		2011-2-10					
				M. Ito		Feb/10					
										Rev. A	

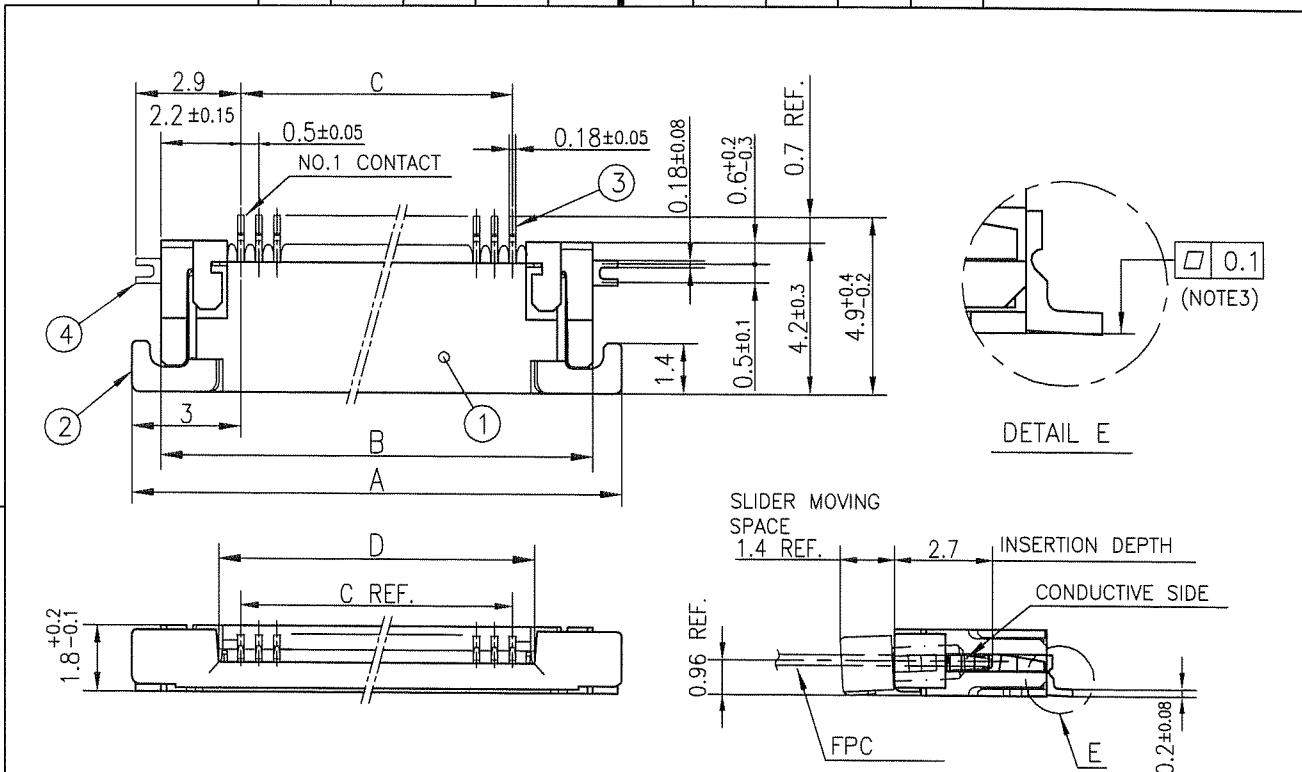

PT. NO.	PARTS NAME	MATERIAL	Q'TY	NOTE
1	HOUSING	13~35pin : LCP RESIN GLASS REINFORCED (UL94V-0)	1	COLOR : BLACK (HALOGEN FREE)
		4~12pin : POLYAMIDE RESIN GLASS REINFORCED (UL94V-0)		
2	SLIDER	PPS RESIN GLASS REINFORCED (UL94V-0)	1	COLOR : BLACK (HALOGEN FREE)
3	CONTACT	PHOSPHOR BRONZE	n	PLATING : MATTE PURE TIN Ni UNDER PLATED (LEAD FREE)
4	MOUNTING PLATE		2	

RECOMMENDED PC BOARD LAYOUT  
(COMPONENT SIDE)

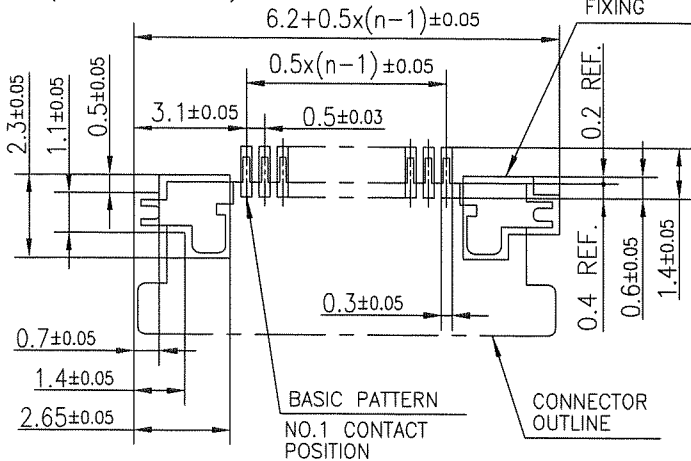

n : NO. OF CONTACTS

NOTES

1. THIS PRODUCT IS THE CONNECTOR USED FOR FPC AND COPS WITH AUTOMATIC MOUNTING (SMT).
2. THIS PRODUCT IS UPPER CONTACT TYPE CONNECTOR.
3. FLATNESS OF CONTACT TERMINAL AND MOUNTING PLATE MUST BE WITHIN TOLERANCE IN E PORTION DETAILED DRAWING.
4. THIS PRODUCT MEETS EUROPEAN UNION DIRECTIVES AND OTHER COUNTRY REGULATIONS AS DESCRIBED IN GS-22-008.
5. THE HOUSING WILL WITHSTAND EXPOSURE TO 260°C PEAK TEMPERATURE FOR 10 SECONDS IN A REFLOW SOLDERING OVEN.

mat'l. code		surface		tolerance		projection		product family		CODE	
		ISO 1302 ✓		ISO 406				58EF		JP	
ltr		ecn no		dr		date		title			
A								CONNECTOR USED FOR FPC WITH 0.5 mm CONTACT SPACING (Cat. No. : SFV__R-2ST__HLF)			
		angles		linear		mm		scale			
								dwg no		sheet 4 of 9 size	
								10117320		A4	
								type		Product Customer Drawing	
sheet index		revision sheet								Rev. A	

CAT. NO. & DIMENSIONS

NO. OF CONTACTS (n)	CAT. NO.	DIMENSIONS (NOTE3)		
		F MAX.	G ± 0.3	H ± 0.1
4	SFV4R-1/2STE9HLF	22.4	16	—
5	SFV5R-1/2STE9HLF	22.4	16	—
6	SFV6R-1/2STE9HLF	22.4	16	—
7	SFV7R-1/2STE9HLF	30.4	24	—
8	SFV8R-1/2STE9HLF	30.4	24	—
9	SFV9R-1/2STE9HLF	30.4	24	—
10	SFV10R-1/2STE9HLF	30.4	24	—
11	SFV11R-1/2STE9HLF	30.4	24	—
12	SFV12R-1/2STE9HLF	30.4	24	—
13	SFV13R-1/2STE9HLF	30.4	24	—
14	SFV14R-1/2STE9HLF	30.4	24	—
15	SFV15R-1/2STE9HLF	30.4	24	—
16	SFV16R-1/2STE9HLF	30.4	24	—
17	SFV17R-1/2STE9HLF	30.4	24	—
18	SFV18R-1/2STE9HLF	30.4	24	—
19	SFV19R-1/2STE9HLF	30.4	24	—
20	SFV20R-1/2STE9HLF	30.4	24	—
21	SFV21R-1/2STE9HLF	30.4	24	—
22	SFV22R-1/2STE9HLF	30.4	24	—
23	SFV23R-1/2STE9HLF	38.4	32	28.4
24	SFV24R-1/2STE9HLF	38.4	32	28.4
25	SFV25R-1/2STE9HLF	38.4	32	28.4
26	SFV26R-1/2STE9HLF	38.4	32	28.4
27	SFV27R-1/2STE9HLF	38.4	32	28.4
28	SFV28R-1/2STE9HLF	38.4	32	28.4
29	SFV29R-1/2STE9HLF	38.4	32	28.4
30	SFV30R-1/2STE9HLF	38.4	32	28.4
31	SFV31R-1/2STE9HLF	50.4	44	40.4
32	SFV32R-1/2STE9HLF	50.4	44	40.4
33	SFV33R-1/2STE9HLF	50.4	44	40.4
34	SFV34R-1/2STE9HLF	50.4	44	40.4
35	SFV35R-1/2STE9HLF	50.4	44	40.4

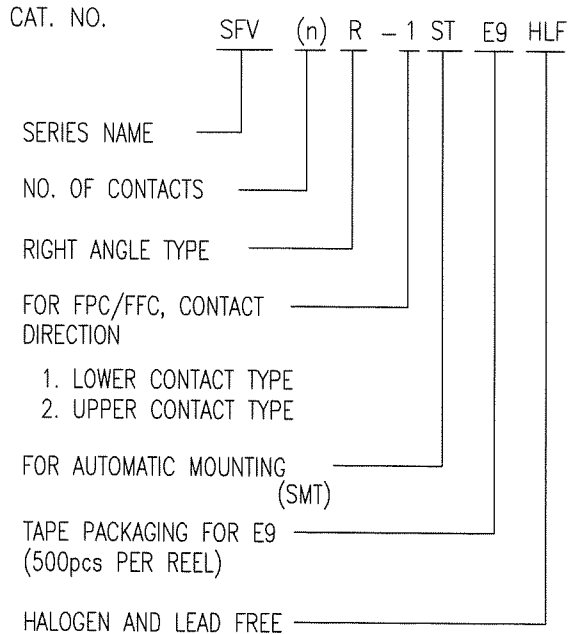

NOTES

1. THIS PRODUCT IS THE CONNECTOR USED FOR FPC AND COPES WITH AUTOMATIC MOUNTING (SMT).
2. THIS CATALOG NO. INDICATES PLASTIC TAPE PACKAGED CONNECTOR.
3. SEE PART DRAWINGS FOR DIMENSIONS F~H.



Copyright FCI.

mat'l. code				surface ISO 1302 <input checked="" type="checkbox"/>		tolerance ISO 406 ISO 1101		projection 		product family 58EF		CODE JP	
ltr		ecn no		dr		date		tolerances unless otherwise specified		title		sheet 5 of 9	
A								angles linear		CAT. NO. TABLE FOR PLASTIC TAPE PACKAGED 0.5 mm CONTACT SPACING CONNECTOR (Cat. No. : SFV__R-1/2STE9HLF)		size A4	
								scale X		dwg no 10117320		type Product Customer Drawing	
				dr		S. Witala 2011-2-10		FCI				Rev. A	
				enr		S. Witala 2011-2-10							
				chr		Y. Kameda 2011-2-10							
				appd		M. W. Feb 10 11							
sheet index		revision sheet											

TOLERANCES  
UNLESS OTHERWISE SPECIFIED : ±5, ANGLE ±5°

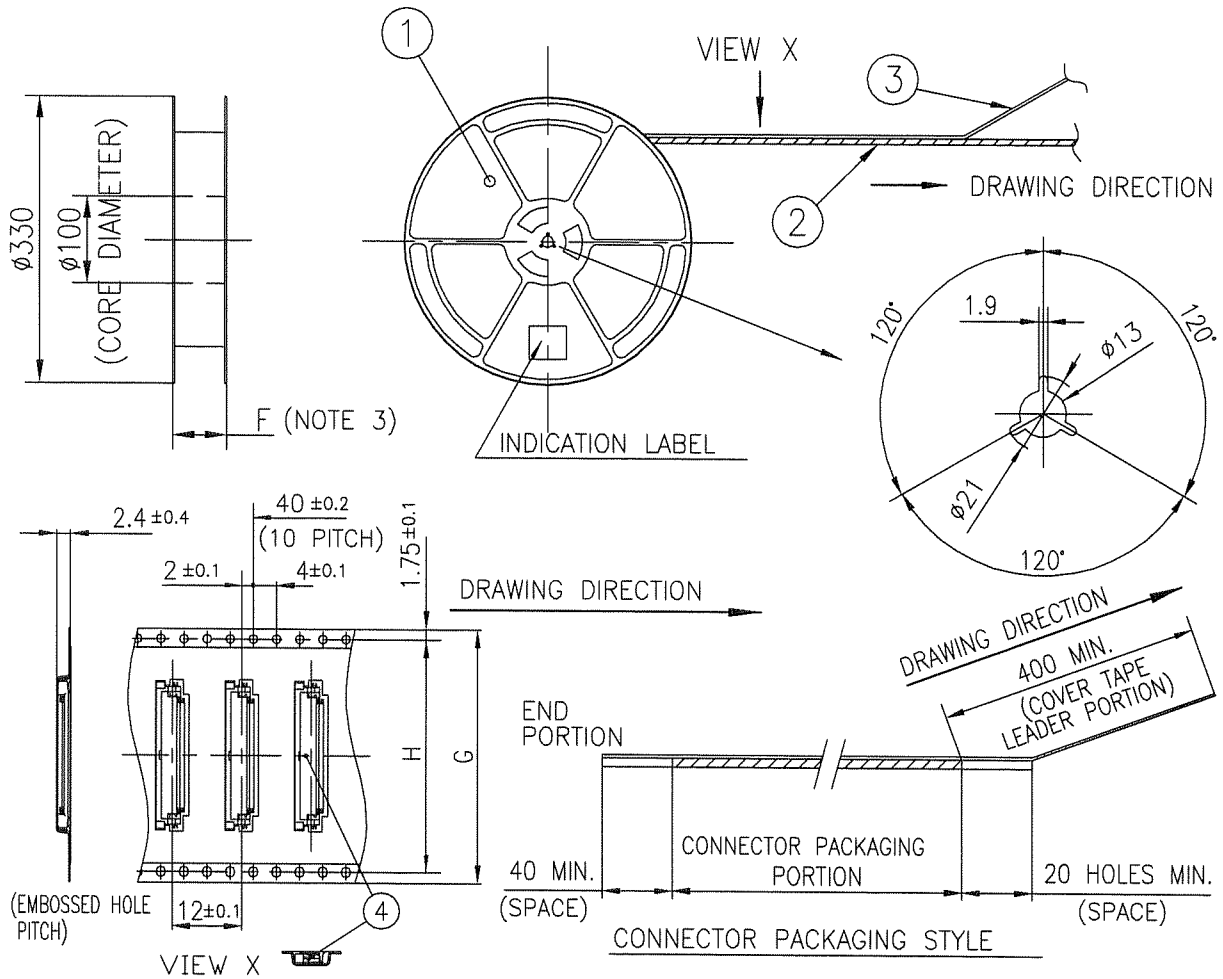

PT. NO.	PARTS NAME	CAT. NO.	MATERIAL	Q'TY	NOTE
1	REEL	_____	POLYSTYRENE	1	COLOR : BLACK
2	PLASTIC (EMBOSS) TAPE	_____	A-PET	_____	COLOR : TRANSPARENCY (CLEAR)
3	COVER	_____	POLYESTER	_____	COLOR : TRANSPARENCY (CLEAR)
4	CONNECTOR	SFV__R-1ST__HLF	SEE ATTACHED DWG.	500	LOWER CONTACT TYPE

NOTES

1. THIS IS PLASTIC TAPE PACKAGED CONNECTOR USED FOR FPC AND COPES WITH AUTOMATIC MOUNTING (SMT).
2. SEE JIS C 0806 (PACKING OF ELECTRONIC COMPONENTS ON CONTINUOUS TAPES (SURFACE MOUNTING DEVICES)) FOR SHAPE AND DIMENSIONS OF PLASTIC (EMBOSS) TAPE AND REEL.
3. F DIMENSION IS PORTION OF THE CORE.

mat'l. code		surface ISO 1302 <input checked="" type="checkbox"/>		tolerance ISO 406 <input checked="" type="checkbox"/> ISO 1101		projection 		product family 58EF		CODE JP	
ltr		ecn no		dr		date		tolerances unless otherwise specified		title PLASTIC TAPE PACKAGED 0.5 mm CONTACT SPACING CONNECTOR (Cat. No. : SFV__R-1STE9HLF)	
A								angles linear		mm	
								scale $\times$		dwg no 10117320	
				dr		2011-2-10				sheet 6 of 9	
				enrg		2011-2-10				size A4	
				chr		2011-2-10				type Product Customer Drawing	
sheet index		revision sheet								Rev. A	

form: A4

1

2

TOLERANCES  
UNLESS OTHERWISE SPECIFIED : ±5, ANGLE ±5°

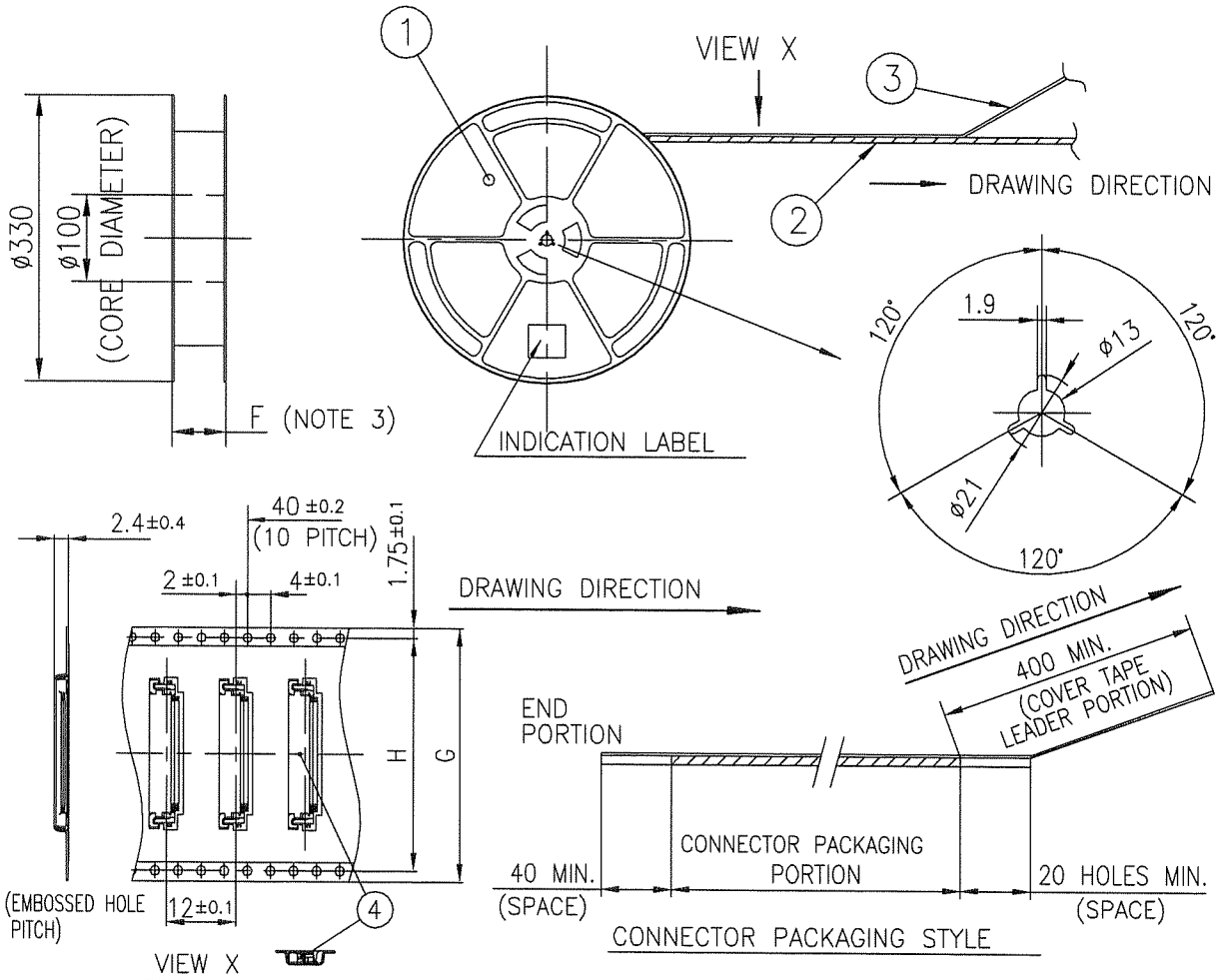

PT. NO.	PARTS NAME	CAT. NO.	MATERIAL	Q'TY	NOTE
1	REEL	_____	POLYSTYRENE	1	COLOR : BLACK
2	PLASTIC (EMBOSS) TAPE	_____	A-PET	_____	COLOR : TRANSPARENCY (CLEAR)
3	COVER	_____	POLYESTER	_____	COLOR : TRANSPARENCY (CLEAR)
4	CONNECTOR	SFV__R-2ST__HLF	SEE ATTACHED DWG.	500	LOWER CONTACT TYPE

NOTES

1. THIS IS PLASTIC TAPE PACKAGED CONNECTOR USED FOR FPC AND COPES WITH AUTOMATIC MOUNTING (SMT).
2. SEE JIS C 0806 (PACKING OF ELECTRONIC COMPONENTS ON CONTINUOUS TAPES (SURFACE MOUNTING DEVICES)) FOR SHAPE AND DIMENSIONS OF PLASTIC (EMBOSS) TAPE AND REEL.
3. F DIMENSION IS PORTION OF THE CORE.

mat'l. code		surface ISO 1302 ✓		tolerance ISO 406 ISO 1101		projection mm		product family 58EF		CODE JP	
ltr		ecn no		dr		date		title PLASTIC TAPE PACKAGED 0.5 mm CONTACT SPACING CONNECTOR (Cat. No. : SFV__R-2STE9HLF)		dwg no 10117320	
A								sheet 7 of 9		size A4	
sheet index		revision sheet		dr S. Mitani 2011-2-10		enr S. Mitani 2011-2-10		chr Y. Kamada 2011-2-10		appd M. Ito 2011-2-10	
								type Product Customer Drawing		Rev. A	



FCJconnect.com

Copyright FCI.



RECOMMENDED CABLE (FPC)

n : NO. OF CONTACTS

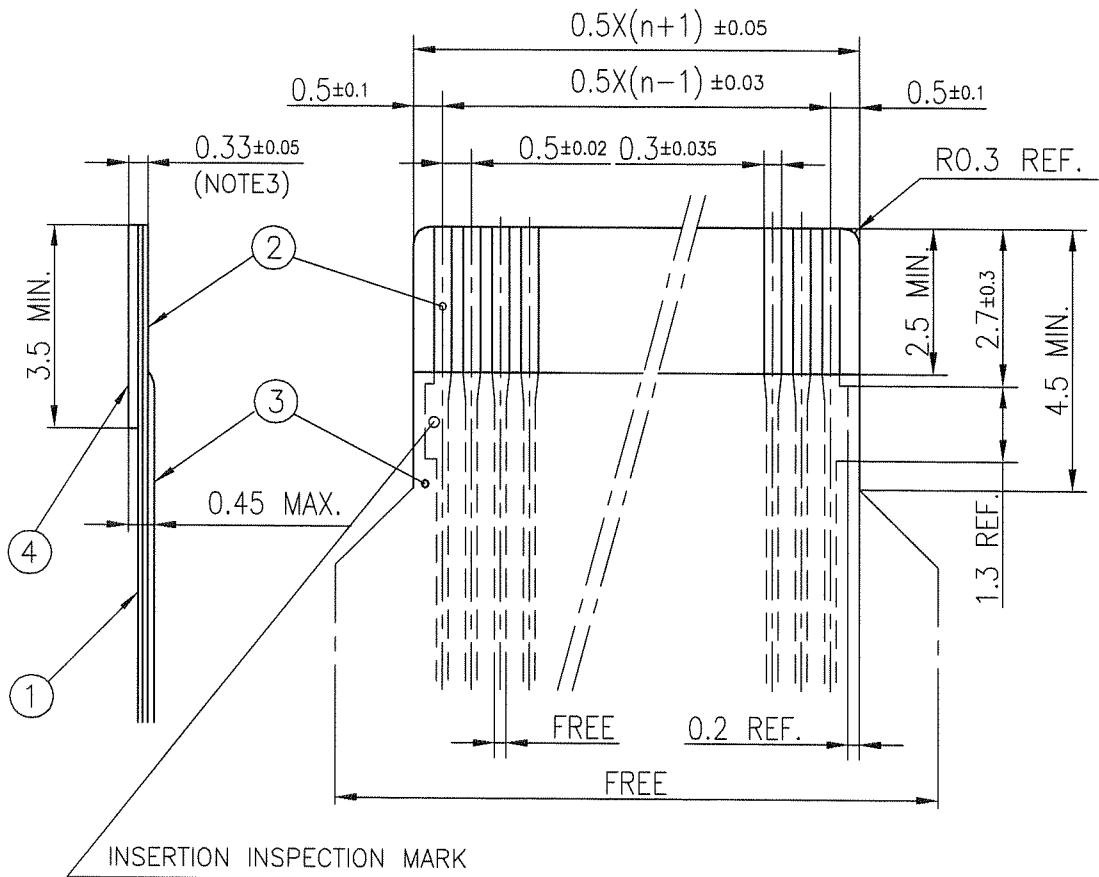

INSERTION INSPECTION MARK

PT. NO.	PARTS NAME	MATERIAL	THICKNESS (um)
1	BASE FILM	POLYIMIDE OR POLYESTER OR EQUAL	25
2	CONDUCTOR	COPPER FOIL(PLATING : TIN or SOLDER 1um MIN.)	35
3	OVERLAY	POLYIMIDE OR POLYESTER OR EQUAL	—
4	SUPPORTING TAPE	POLYESTER OR POLYIMIDE OR EQUAL	188

NOTES

1. NO BURR AT EACH PORTION.
2. NO PEELING IN COMMON USE.
3. TOTAL THICKNESS LIMIT OF EACH MATERIAL (INCLUDING ADHESIVE AGENT) IS SPECIFIED.

mat'l. code				surface ISO 1302 <input checked="" type="checkbox"/>	tolerance ISO 406 ISO 1101	projection 	product family 58EF	CODE JP	
ltr	ecn no	dr	date	tolerances unless otherwise specified		mm 	title RECOMMENDED CABLE (Cat. No. : SFV__R-1/2ST__)		
A				angles	linear		scale $\times$	dwg no 10112793	
				dr	<i>S. Withler</i> 2011-2-10		sheet 8 of 9	size A4	
				enr	<i>S. Withler</i> 2011-2-10		type Product Customer Drawing		
				chr	<i>Y. Komeda</i> 2011-2-10				
				appd	<i>M. Ueda</i> Feb 10/11				
sheet index	revision sheet							Rev. A	

form: A4



RECOMMENDED CABLE (FFC)

n : NO. OF CONTACTS

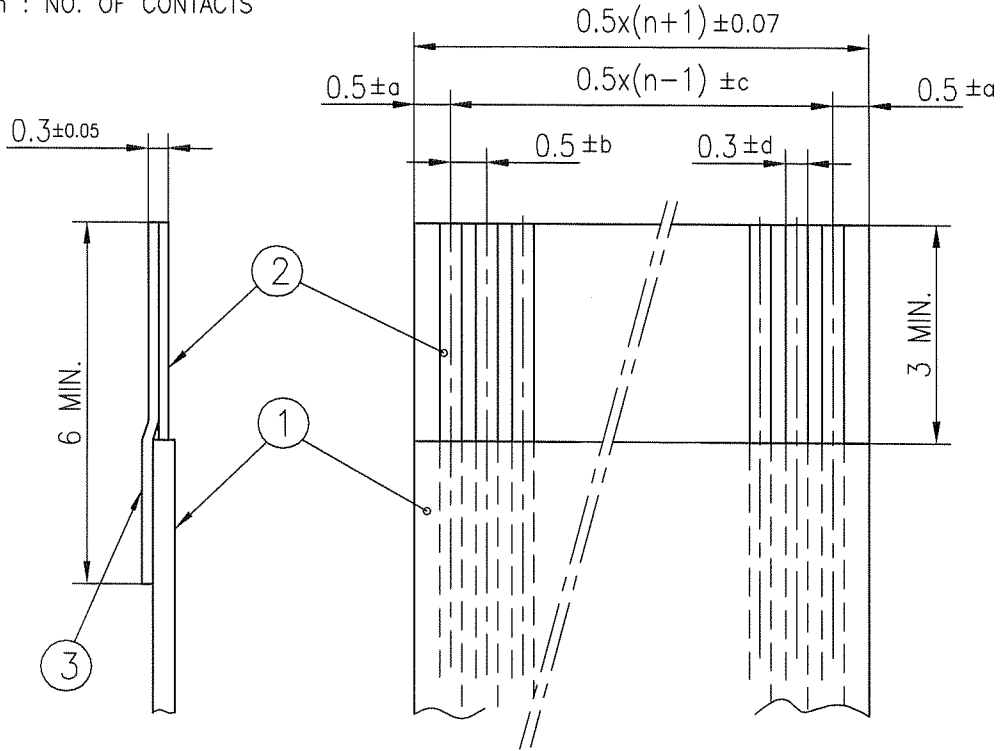

KIND OF FFC (NOTE3)	DIMENSIONAL TOLERANCE			
	a	b	c	d
1	±0.07	±0.04	±0.05	±0.02
2	±0.1	±0.03	±0.03	±0.025

PT. NO.	PARTS NAME	MATERIAL	NOTE
1	INSULATOR	FLAME RESISTING POLYESTER OR EQUAL	_____
2	CONDUCTOR	COPPER FOIL:THICKNESS 35 OR 50um	PLATING : TIN OR SOLDER 1um MIN.
3	SUPPORTING TAPE	FLAME RESISTING POLYESTER OR EQUAL	_____

NOTES

1. NO BURR AT EACH PORTION.
2. NO PEELING IN COMMON USE.
3. EITHER KIND1 OR KIND2 OF FFC CAN ACCEPT DIMENSIONAL TOLERANCE a,b,c AND d.

mat'l. code				surface ISO 1302 <input checked="" type="checkbox"/> ISO 406 ISO 1101		tolerance ISO 406 ISO 1101		projection 		product family 58EF		CODE JP	
ltr				ecn no		dr		date		title RECOMMENDED CABLE (Cat. No. : SFV__R-1/2ST__LF)			
A													
				angles		linear		mm		scale $\times$			
				dr		S. Mitoh 2011-2-10		FCJ		dwg no		sheet 9 of 9	
				engr		S. Mitoh 2011-2-10				10117320		size A4	
				chr		Y. Kamada 2011-2-10				type		Product Customer Drawing	
				appd		M. Arita Feb 10 2011						Rev. A	
sheet index		revision sheet											

form: A4

1

2



FCJconnect.com

Copyright FCI.