

BC805M Compact, Lowest Cost BLE 5.2 Module

Ver 1.02, Jan. 2021

BluNor BC805M Series module is a powerful, highly flexible, ultra low power Bluetooth Low Energy (BLE) using Nordic nRF52805 SoC. With an ARM Cortex™ M4 MCU, available 192KB flash, 24 KB RAM, embedded 2.4GHz multi-protocol transceiver, and an integrated PCB trace antenna. It allows faster time to market with reduced development cost.



Specifications:

- nRF52805, ARM Cortex M4, 64 MHz
- Flash/RAM: 192KB/24KB.
- Complete RF solution with integrated antenna
- BLE 5 data: 2Mbps, 1Mbps
- Proprietary 2.4 GHz protocols
- DC-DC converter, inductors on board.
- 4.6 mA peak current at 0 dBm TX.
- 4.6 mA peak current at RX.
- 32 MHz main crystal on board.
- Embedded RC sleep oscillator or external 32.768 KHz sleep crystal
- Serial Wire Debug (SWD)
- Supports SoftDevice S112, S113 soon.
- Up to 4 connections as a Peripheral concurrently with a Broadcaster.
- Supports Bluetooth Channel Selection Algorithm #2 (CSA#2). Improving coexistence and reducing interference.
- Over-the-Air (OTA) firmware update
- Programmable peripheral interconnect (PPI)
- 2-channel 12 bit/200kbps ADC
- Temperature sensor
- 3 x 32 bit timers with counter mode
- SPI masters/slaves
- I2C compatible 2-wire masters/slaves
- 1x UART (CTS/RTS)
- 2x real time counters (RTC)
- AES hardware encryption
- SoC Receiver Sensitivity: -97 dBm at 1Mbps
- SoC TX power: programmable +4dBm to -20dBm in 4 dB step.
- Max. TX power per FCC reports: +5.2 dBm.
- Castellated 14 pins.
- 10 GPIO pins plus SWDIO, SWDCLK.
- Operation voltage: 1.7V to 3.6V
- Operation temperature: -40°C to +85°C
- QDID: 138610
- FCC ID: X8WBC805M
- ISED ID: 4100A-BC805M
- CE: Compliant (including EN300 328 V2.2.2)
- Japan TELEC: 201-200778/00
- Australia RCM: Compliant

Model Summaries

module	BC805M
MCU	nRF52805
Flash/RAM	192KB/24KB
Size, mm	10x14.3x1.9
Max. TX power	+5.2 dBm
BT Antenna	PCB trace
BT range, 1 Mbps, LMP1	340 meters, est.
BT range, 1Mbps, 1.52m	270 meters, est.
Availability	Production

Table Of Contents

1. Introduction.....	3
BC805M Block Diagram	3
BC805M Compact BLE 5.2 Module.....	3
2. Codes Development Using Nordic Tools	4
Easy, fast and safe code development.....	4
Over-The-Air DFU	4
SoftDevices	4
Development Tools	4
3. Product Descriptions	5
Block Diagram of nRF52805	5
Mechanical Drawings	6
Pin Assignments of BC805M	7
Pin Function.....	7
Mounting BC805M on the Host PCB	8
Host Board Layout.....	8
4. Bluetooth Range Measurements	9
Estimated Measurement Results.....	9
Deployment Recommendations	9
5. BC805M Evaluation Board	10
Nordic Development Tools.....	10
Android OS Apps	11
iOS Apps	11
BC805M EvaluationBoard Schematics.....	12
Suggestion for Battery Power Application	13
6. Production	14
Preloaded Firmware	14
AT Command Codes	14
Soldering Temperature-Time Profile for Re-Flow Soldering	15
Cautions, Design Notes, and Installation Notes	15
Packaging.....	18
FCC Label	18
Revision History	19
7. Contact Us.....	20

1. Introduction

BluNor BC805M is powerful, highly flexible, ultra low power wireless modules using Nordic nRF52805 SoCs. With an ARM Cortex™ M4 MCU, up to 192KB flash, 24KB RAM, embedded 2.4GHz multi-protocol transceiver, and an integrated antenna, it allows faster time to market with reduced development cost.

The following is a block diagram of BC805M. Antenna circuit and main clock are integrated. All 10 GPIOs of nRF52805 can be accessed from main board.

BC805M Block Diagram

BC805M block diagram is below.

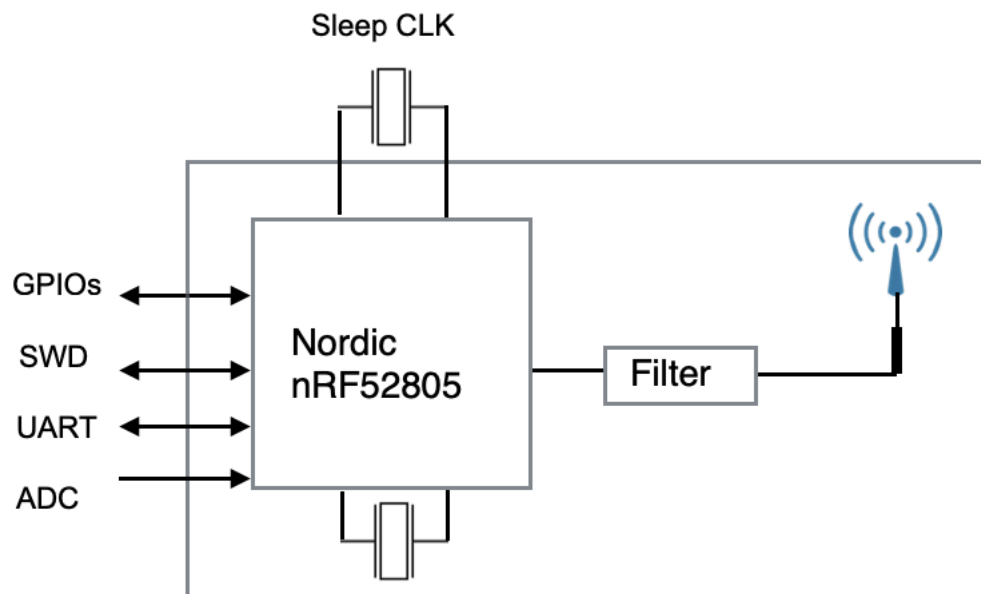

BC805M Compact BLE 5.2 Module

- nRF52805, Cortex M4 MCU, 64 MHz
- 192KB flash, 24 KB RAM
- 14 LGA pins, 10 GPIOs, SWDIO, SWDCLK
- Integrated PCB trace antenna
- Size 10x14.3x1.9mm
- Bluetooth range: 340 meters at 1 Mbps, estimated.

2. Codes Development Using Nordic Tools

Development tools by Nordic and other third party development tools recommended by Nordic should be used .

Easy, fast and safe code development

Nordic development environment for BC805 offers a clean separation between application code development and embedded protocol stacks. This means compile, link and run time dependencies with the embedded stack and associated debugging challenges are removed. The Bluetooth low energy and ANT stack is a pre-compiled binary, leaving application code to be compiled stand-alone. The embedded stack interface uses an asynchronous and event driven model removing the need for RTOS frameworks.

Over-The-Air DFU

The BC805 is supported by an Over-The-Air Device Firmware Upgrade (OTA DFU) feature. This allows for in the field updates of application software and SoftDevice.

SoftDevices

The Nordic protocol stacks are known as SoftDevices and complement the nRF52 Series SoCs. All nRF52 Series are programmable with software stacks from Nordic. This bring maximum flexibility to application development and allows the latest stack version to be programmed into the SoC.

SoftDevices available from Nordic:

S112: Bluetooth low energy concurrent central/peripheral/observer/broadcaster stack.

Development Tools

Nordic Semiconductor provides a complete range of hardware and software development tools for the nRF52 Series devices. nRF52 DK board is recommended for firmware development.

Nordic software development tools can be downloaded from the following webpage.

http://infocenter.nordicsemi.com/index.jsp?topic=/com.nordic.infocenter.nrf52/dita/nrf52/development/nrf52_dev_kit.html&cp=1_1

3. Product Descriptions

Brief description of nRF52805 SoC is provided. For full description of the SoC, please download from Nordic Semiconductor website.

<https://www.nordicsemi.com/Products/Low-power-short-range-wireless/nRF52805>

Block Diagram of nRF52805

The following is a block diagram of Nordic nRF52805 Bluetooth Low Energy (BLE) SoC. Arrows with white heads indicate signals that share physical pins with other signals.

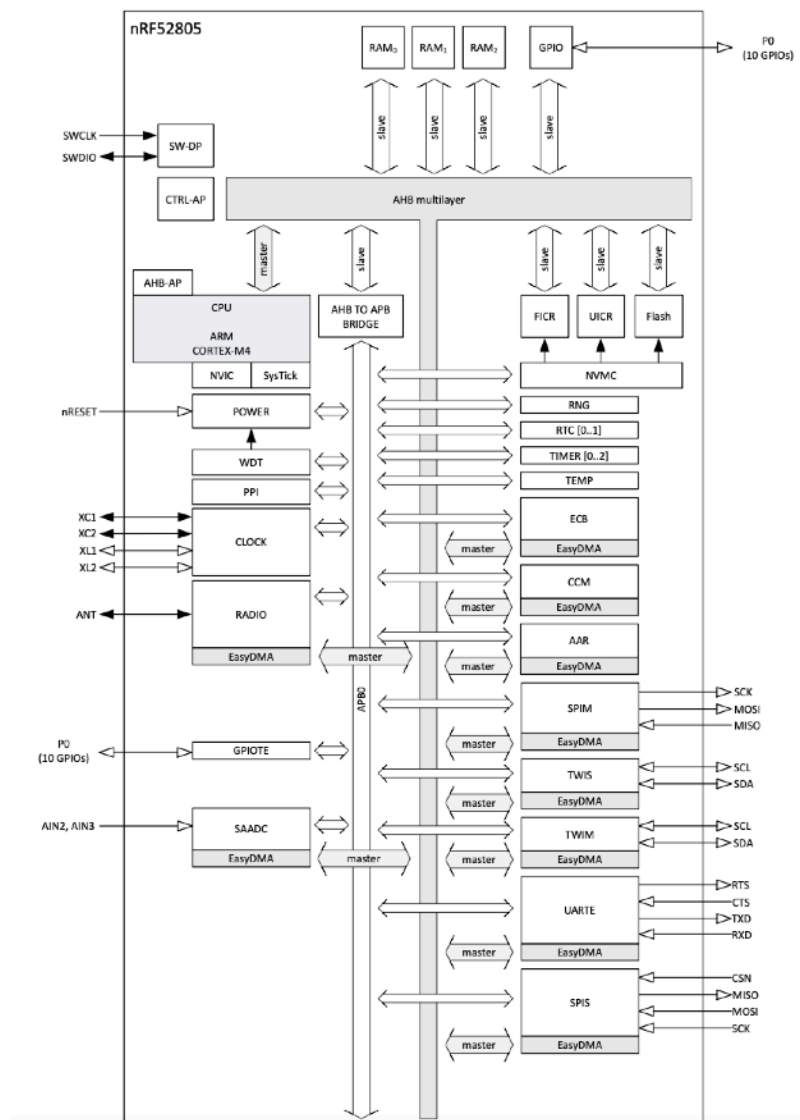

The 32 bit ARM Cortex M4 MCU with hardware supports for DSP instructions, code density and execution speed are higher than other Cortex M MCU. The Programmable Peripheral Interconnect (PPI) system provides a 20-channel bus for direct and autonomous system peripheral communication without CPU intervention. This brings predictable latency times for peripheral to peripheral interaction and power saving benefits associated with leaving CPU idle. The device has 2 global power modes ON/OFF, but all system blocks and peripherals have individual power management control which allows for an automatic switching RUN/IDLE for system blocks based only on those required/not required to achieve particular tasks.

BC805M Compact, Lowest Cost BLE 5.2 Module

Ver 1.02, Jan. 2021

Mechanical Drawings

The followings are mechanical drawings of BC805M. Size is 10x14.3mm. It has 14 castellated pins. Top view of module:

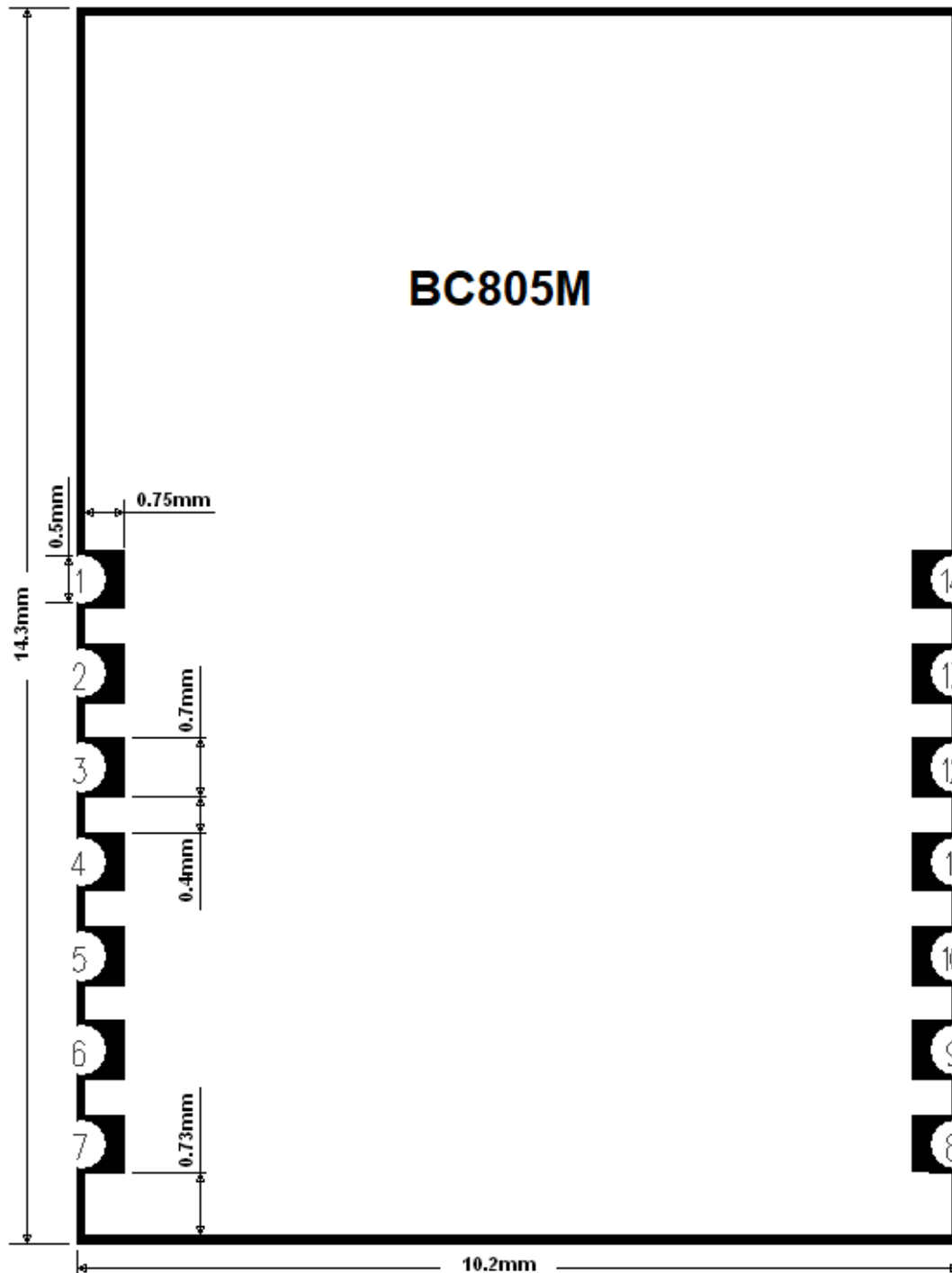

BC805M Compact, Lowest Cost BLE 5.2 Module

Ver 1.02, Jan. 2021

Pin Assignments of BC805M

The followings are BC805M pin assignment. Pin functions are in a table in next section. Please refer to Nordic nRF52805 Product Specifications for detailed descriptions and features supported.

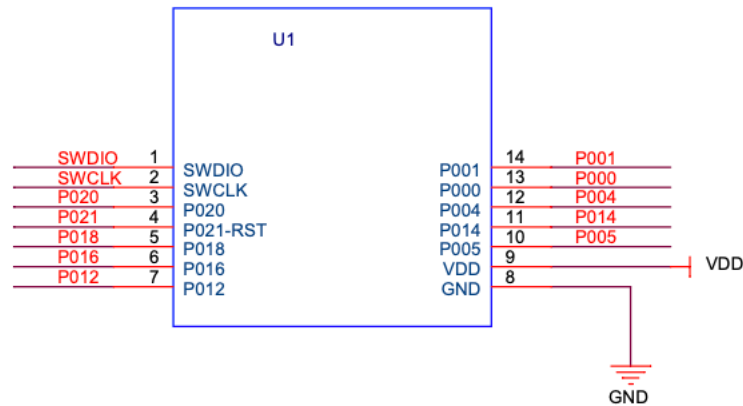

Pin Function

BC805M	nRF52805	BC805M	
pin#	pin#	pin name	Descriptions
1	F1	SWDIO	Serial Wire Debug I/O for debug and programming
2	G1	SWDCLK	Serial Wire Debug clock input
3	F2	P020	GPIO. Digital
4	G2	P021-RST	GPIO, digital, configurable as reset
5	G3	P018	GPIO, digital
6	G4	P016	GPIO, digital
7	G5	P012	GPIO, digital
8	E4	GND	Ground
9	A6	VDD	Power supply (battery)
10	F6	P005	GPIO, digital or analog (AIN3)
11	F4	P014	GPIO, digital
12	F5	P004	GPIO, digital or analog (AIN2)
13	D6	P000	GPIO, digital or 32.768 KHz clock connection
14	D5	P001	GPIO, digital or 32.768 KHz clock connection

Mounting BC805M on the Host PCB

The following figure shows recommended mounting of BC805 module on the host PCB.

- For the best Bluetooth range performance, the antenna area of BC805M module shall extend 4.4 mm outside the edge of host PCB board, or 4.4 mm outside the edge of a ground plane.
- The next choice is to place BC805M on a corner of host PCB, the antenna area shall extend 4.4 mm from the edge of ground plane. Ground plane shall be at least 5 mm from the edge of the antenna area of module.
- We don't recommend mounting BC805M module in the middle of a host PCB.

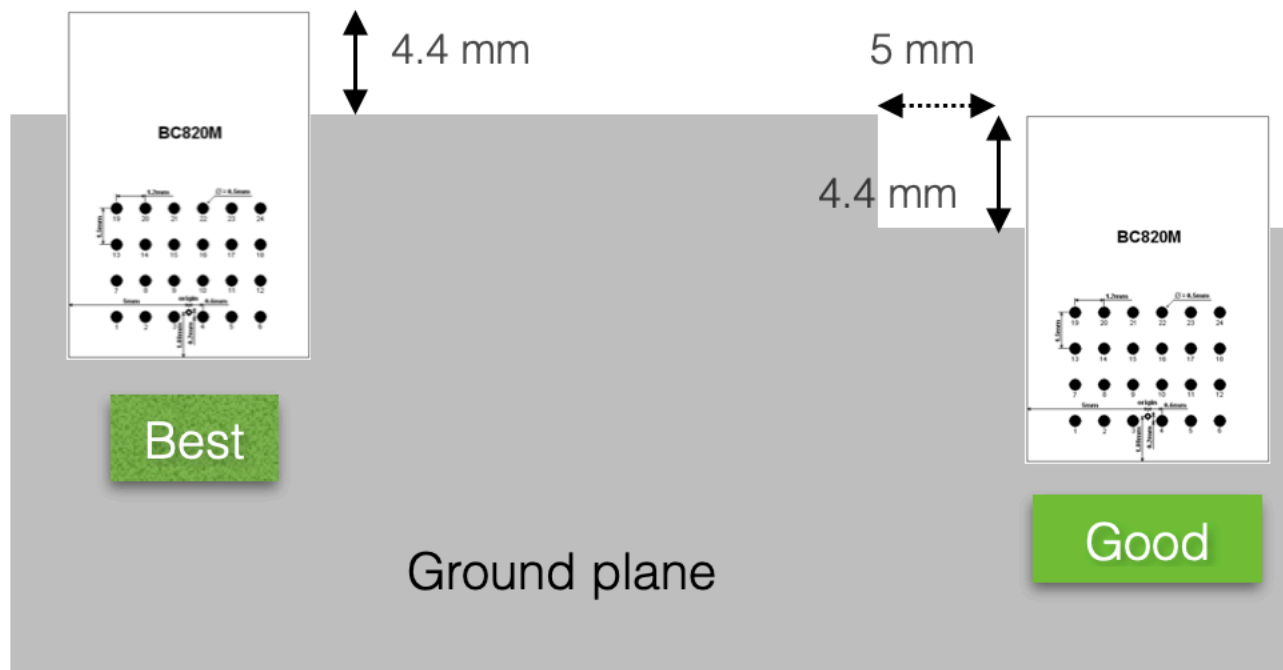

For the best Bluetooth range performance, keep all external metal at least 30mm from the antenna area.

Host Board Layout

Library components for some PCB layout software are available. Or, it can be extracted from EV-BC805M evaluation board Gerber files. Gerber files can be downloaded from:

<http://www.fanstel.com/download-document/>.

4. Bluetooth Range Measurements

Bluetooth range measurement hex codes can be downloaded from **Bluetooth Range Measurements** section of this webpage.

<http://www.fanstel.com/download-document/>

Description of measurement site, measurement methods, and range raw data are available at:

<https://www.fanstel.com/testreport/>

Estimated Measurement Results

Bluetooth ranges are measured for antennas at two heights.

- 1.52 meters or 5 feet, the typical height of thermostat in the USA.
- Low Multiple Path Interference (LMPI) or 60% Fresnel zone clearance.

Data rate/Antenna height, meters	BC805M
1Mbps/1.52 meters, between modules	270 meters, est.
1Mbps/LMPI, between modules	340 meters, est.

Deployment Recommendations

- To have the best Bluetooth data reception, direct line of sight between 2 devices should be away from ground or wall.
- If one device must be installed closer to ground or a wall, install other devices far away from a wall or ground.
- Indoor condition is different for different building. We suggest testing Bluetooth data reception in the building with the worst case condition.

BC805M Compact, Lowest Cost BLE 5.2 Module

5. BC805M Evaluation Board

An evaluation board consists of the followings:

- Mini USB cable
- Evaluation board
- 10-conductor cable for connection to Nordic nRF52 DK (DK is not included)



Nordic Development Tools

A Nordic nRF52832-DK or nRF52840-DK is recommended for programming this evaluation board. Nordic development tools can be downloaded from:

<https://www.nordicsemi.com/Products/Low-power-short-range-wireless/nRF52805>

Many application examples can be downloaded from Nordic website.

Some firmware, Android OS, and iOS app codes can be downloaded from **Bluetooth 5 Codes** section of this Fanstel webpage.

<http://www.fanstel.com/download-document/>

BC805M Compact, Lowest Cost BLE 5.2 Module

Ver 1.02, Jan. 2021

To program BC805M on the evaluation board:

- Download and set up on your Windows PC or MAC, nRF command line tool 10.2.1 or newer.
<https://www.nordicsemi.com/Software-and-Tools/Development-Tools/nRF-Command-Line-Tools/Download>
- Download and set up on your Windows PC or MAC, nRF Connect desktop 3.2.0 or newer.
<https://www.nordicsemi.com/Software-and-Tools/Development-Tools/nRF-Connect-for-desktop>
- Connect EV-BC805M to the **Debug out** connector of a Nordic nRF52832-DK or nRF52840-DK.

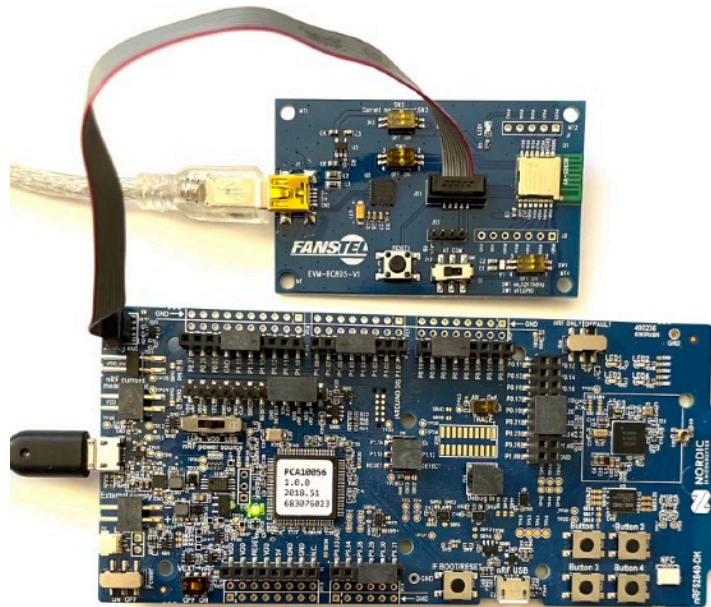

- Use *nRF Connect* to program BC805M module on the EV board.

Android OS Apps

The following Android OS apps are available for download from Google Play Store:

BlueNor nrf5x: to use with Bluetooth 5 stacks, AT commands, or Slave firmware. Master firmware does not connect to a smartphone. Source codes can be downloaded from <http://www.fanstel.com/download-document/>

BlueNor Mesh: to use with BlueNor mesh firmware to send command to any node in a mesh. Node number is displayed when acknowledgement is received. Source codes will be uploaded to Fanstel website when supporting Bluetooth 5.

iOS Apps

The following iOS apps can be downloaded from Apple APP Store.

BlueNor Mesh: to use with BlueNor mesh firmware to send command to any node in a mesh. Node number is displayed when acknowledgement is received.

BlueNor nrf5x firmware, apps, and source codes will be uploaded when ready.

BC805M Compact, Lowest Cost BLE 5.2 Module

Ver 1.02, Jan. 2021

BC805M EvaluationBoard Schematics

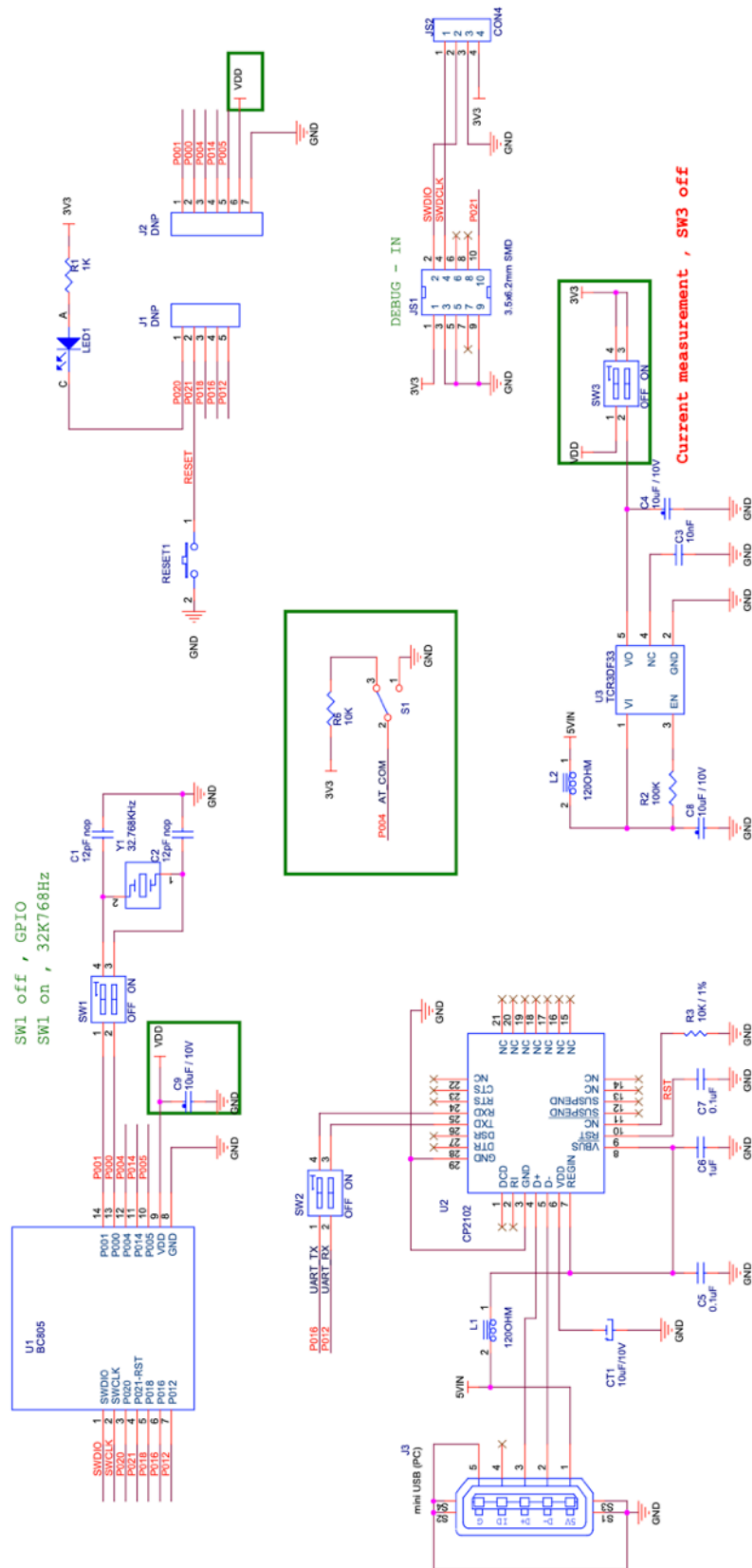

Evaluation board can be used as a reference design for using modules.

Suggestion for Battery Power Application

Standby current consumption is important for battery-powered product. Both 32 MHz main crystal and load capacitors are inside module. You can enable internal RC oscillator for sleep clock or install an external 32.768 sleep crystal.

Two inductors required for on-board DC to DC converter are inside BC805M. You can enable DCDC converter to have lower power consumption.

6. Production

Preloaded Firmware

Production testing codes are not erased before shipping from factory. To load your firmware, please erase the entire chip and re-program using instruction below.

```
//program BT840 Bootloader+Softdevice+Application hex
```

```
nrfjprog -f NRF52 --program BT840_AT_3in1PC181113.hex --chiperase --reset
```

```
//The file BT840_AT_3in1PC181113.hex = softdevice S140v6.1.1+BT840_AT_UARTwithout32K+bootloader
```

AT Command Codes

AT command codes are used for production testing. Up to date codes can be downloaded from:

<https://www.fanstel.com/download-document/>

You can erase and reprogram with your codes. Or, use AT command codes as preloaded.

Because of the size of AT command codes, a bootloader is not included in BC805M. DFU OTA is not possible for the preloaded codes. However, it is possible to erase the preloaded codes and load your own codes with a bootloader through the SWDIO interface.

Programming services are available in factory with MOQ and programming charges.

Soldering Temperature-Time Profile for Re-Flow Soldering

Maximum number of cycles for re-flow is 2. No opposite side re-flow is allowed due to module weight.

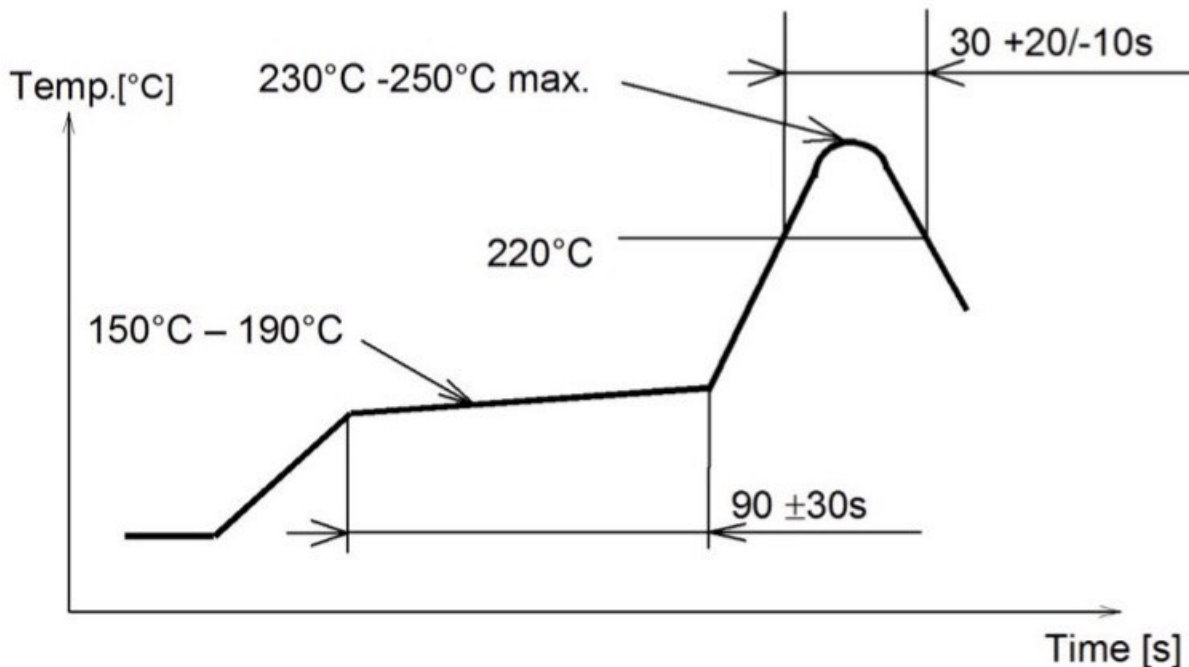

Cautions, Design Notes, and Installation Notes

Failure to follow the guidelines set forth in this document may result in degrading of the product's functions and damage to the product.

Design Notes

- (1) Follow the conditions written in this specification, especially the control signals of this module.
- (2) The supply voltage has to be free of AC ripple voltage (for example from a battery or a low noise regulator output). For noisy supply voltages, provide a decoupling circuit (for example a ferrite in series connection and a bypass capacitor to ground of at least 47uF directly at the module).
- (3) This product should not be mechanically stressed when installed.
- (4) Keep this product away from heat. Heat is the major cause of decreasing the life of these products.
- (5) Avoid assembly and use of the target equipment in conditions where the products' temperature may exceed the maximum tolerance.
- (6) The supply voltage should not be exceedingly high or reversed. It should not carry noise and/or spikes.
- (7) this product away from other high frequency circuits.

Notes on Antenna and PCB Layout

- (1) Don't use a module with internal antenna inside a metal case.
- (2) For PCB layout:

- Avoid running any signal line below module whenever possible,
- No ground plane below antenna,
- If possible, cut-off the portion of main board PCB below antenna.

Installation Notes

- (1) Reflow soldering is possible twice based on the time-temperature profile in this data sheets. Set up the temperature at the soldering portion of this product according to this reflow profile.
- (2) Carefully position the products so that their heat will not burn into printed circuit boards or affect the other components that are susceptible to heat.
- (3) Carefully locate these products so that their temperatures will not increase due to the effects of heat generated by neighboring components.
- (4) If a vinyl-covered wire comes into contact with the products, then the cover will melt and generate toxic gas, damaging the insulation. Never allow contact between the cover and these products to occur.
- (5) This product should not be mechanically stressed or vibrated when reflowed.
- (6) If you want to repair your board by hand soldering, please keep the conditions of this chapter.
- (7) Do not wash this product.
- (8) Refer to the recommended pattern when designing a board.
- (9) Pressing on parts of the metal cover or fastening objects to the metal will cause damage to the unit.
- (10) For more details on LGA (Land Grid Array) soldering processes refer to the application note.

Usage Condition Notes

- (1) Take measures to protect the unit against static electricity. If pulses or other transient loads (a large load applied in a short time) are applied to the products, check and evaluate their operation before assembly on the final products.
- (2) Do not use dropped products.
- (3) Do not touch, damage or soil the pins.
- (4) Follow the recommended condition ratings about the power supply applied to this product.
- (5) Electrode peeling strength: Do not add pressure of more than 4.9N when soldered on PCB
- (6) Pressing on parts of the metal cover or fastening objects to the metal cover will cause damage.
- (7) These products are intended for general purpose and standard use in general electronic equipment, such as home appliances, office equipment, information and communication equipment.

Storage Notes

- (1) The module should not be stressed mechanically during storage.

(2) Do not store these products in the following conditions or the performance characteristics of the product, such as RF performance will be adversely affected:

- Storage in salty air or in an environment with a high concentration of corrosive gas.
- Storage in direct sunlight
- Storage in an environment where the temperature may be outside the range specified.
- Storage of the products for more than one year after the date of delivery storage period.

(3) Keep this product away from water, poisonous gas and corrosive gas.

(4) This product should not be stressed or shocked when transported.

(5) Follow the specification when stacking packed crates (max. 10).

Safety Conditions

These specifications are intended to preserve the quality assurance of products and individual components. Before use, check and evaluate the operation when mounted on your products. Abide by these specifications, without deviation when using the products. These products may short-circuit. If electrical shocks, smoke, fire, and/or accidents involving human life are anticipated when a short circuit occurs, then provide the following failsafe functions, as a minimum.

(1) Ensure the safety of the whole system by installing a protection circuit and a protection device.

(2) Ensure the safety of the whole system by installing a redundant circuit or another system to prevent a dual fault causing an unsafe status.

Other Cautions

(1) This specification sheet is copyrighted. Reproduction of this data sheet is permissible only if reproduction is without alteration and is accompanied by all associated warranties, conditions, limitations, and notices.

(2) Do not use the products for other purposes than those listed.

(3) Be sure to provide an appropriate failsafe function on your product to prevent an additional damage that may be caused by the abnormal function or the failure of the product.

(4) This product has been manufactured without any ozone chemical controlled under the Montreal Protocol.

(5) These products are not intended for other uses, other than under the special conditions shown below. Before using these products under such special conditions, check their performance and reliability under the said special conditions carefully to determine whether or not they can be used in such a manner.

- In liquid, such as water, salt water, oil, alkali, or organic solvent, or in places where liquid may splash.
- In direct sunlight, outdoors, or in a dusty environment
- In an environment where condensation occurs.

BC805M Compact, Lowest Cost BLE 5.2 Module

Ver 1.02, Jan. 2021

- In an environment with a high concentration of harmful gas.
- (6) If an abnormal voltage is applied due to a problem occurring in other components or circuits, replace these products with new products because they may not be able to provide normal performance even if their electronic characteristics and appearances appear satisfactory.
- (7) When you have any question or uncertainty, contact Fanstel.

Packaging

Production modules are delivered in reel, 1000 modules in each reel.

FCC LABEL

The Original Equipment Manufacturer (OEM) must ensure that the OEM modular transmitter must be labeled with its own FCC ID number. This includes a clearly visible label on the outside of the final product enclosure that displays the contents shown below. If the FCC ID is not visible when the equipment is installed inside another device, then the outside of the device into which the equipment is installed must also display a label referring to the enclosed equipment

The end product with this module may subject to perform FCC part 15 unintentional emission test requirement and be properly authorized.

This device is intended for OEM integrator only.

Revision History

- July 2020, Ver. 0.91: Initial draft release.
- Aug. 2020, Ver 0.92: Add EV board schematics.
- Aug. 2020, Ver 0.93: Add product photo
- Oct. 2020, Ver 0.99: Add FCC, ISED, TELEC certification numbers.
- Dec. 2020, Ver. 1.00: Add CE and RCM compliant status, Update photos.
- Dec.2020, Ver. 1.01: Update EV-BC805M schematics.
- Jan. 2021, Ver. 1.02: Add EV-BC805M set up.

7. Contact Us

United States:

Fanstel Corp.

7466 E. Monte Cristo Ave. Scottsdale AZ 85260

Tel. 1 480-948-4928

Fax. 1-480-948-5459

Email: info@fanstel.com

Website: www.fanstel.com

Taiwan:

Fanstel Corp.

10F-10, 79 Xintai Wu Road

Xizhu, New Taipei City, Taiwan 22101

泛世公司

臺灣省新北市汐止區新臺五路79號10樓之10, 22101

Tel. 886-2-2698-9328

Fax. 886-2-2698-4813

Email: info@fanstel.com

Website: www.fanstel.com

China:

Fanstel Technologies Corp.

11 Jiale Street

Ping-Dih, Long-Gang, Shen Zhen, GD 518117

泛世康科技(深圳)有限公司

廣東省深圳市龍崗區坪地鎮佳樂街11號

Tel. 86-755-8409-0928

Fax. 86-755-8409-0973

QQ. 3076221086

Email: info@fanstel.com

Website: www.fanstel.com

Mouser Electronics

Authorized Distributor

Click to View Pricing, Inventory, Delivery & Lifecycle Information:

[Fanstel:](#)

[BC805M](#) [EV-BC805M](#)