

# Series 800 Mighty Mouse with UN Mating Thread Crimp Receptacle Ordering Information

800-010 and 800-011



**In-Line**



**Rear Panel Jam Nut**



**Square Flange**

**Integral Band Platform** for direct attachment of a cable shield using a **BAND-IT**® strap. Install a boot, or overmold onto the band platform. An accessory thread is available for attaching strain reliefs and backshells.

**Three Shell Options:** Jam nut with o-ring for rear panel mounting, square flange or in-line receptacle for free-hanging cables.

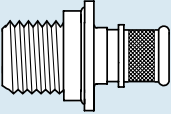
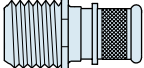
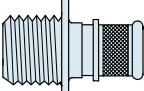
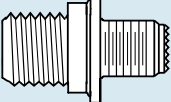
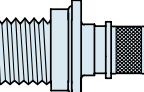
HOW TO ORDER					
Sample Part Number					
800-011	-01	M	6-4	P	N
Series	Shell Style	Shell Material / Finish	Shell Size- Insert Arrangement	Contact Type	Shell Key Position
 <b>800-010</b> Receptacle with Banding Platform	 <b>-01</b> In-Line	<b>C</b> Aluminum / Black Anodize (Non-Conductive) RoHS Compliant	SEE <b>CONTACT ARRANGEMENTS</b> PAGE C-2	<b>Connector supplied with contacts</b> <b>P</b> Pin <b>S</b> Socket <b>Connector supplied without contacts</b> <b>A</b> Pin Connector, less contacts <b>B</b> Socket Connector, less contacts  Connectors with contacts are supplied with signal and/or power crimp contacts. These contacts are not installed.  Coaxial contacts and non-standard signal contacts are ordered separately.	<b>N</b> Normal
	 <b>-02</b> Square Flange for Front or Rear Mounting	<b>M</b> Aluminum / Electroless Nickel RoHS Compliant			<b>X</b> Pos. X
	 <b>800-011</b> Receptacle with Accessory Thread	 <b>-07</b> Jam Nut for Rear Panel Mounting			<b>NF</b> Aluminum / Cadmium with Olive Drab Chromate <b>ZN</b> Aluminum / Zinc-Nickel with Olive Drab Chromate <b>ZNU</b> Aluminum / Zinc-Nickel with Black Chromate <b>MT</b> Aluminum / Nickel-PTFE RoHS Compliant <b>Z1</b> Stainless Steel / Passivated RoHS Compliant

Dimensions in inches (millimeters) and are subject to change without notice.

© 2010 Glenair, Inc.

CAGE Code 06324

Printed in U.S.A.

**GLENAIR, INC. • 1211 AIR WAY • GLENDALE, CA 91201-2497 • 818-247-6000 • FAX 818-500-9912**

www.glenair.com

**C-7**

E-Mail: sales@glenair.com

7 - MARCH - 2013



# Series 800 Mighty Mouse with UN Mating Thread Jam Nut Crimp Receptacle Dimensions 800-010-07 and 800-011-07

**Integral Band Platform**  
800-010-07

**Accessory Thread**  
800-011-07

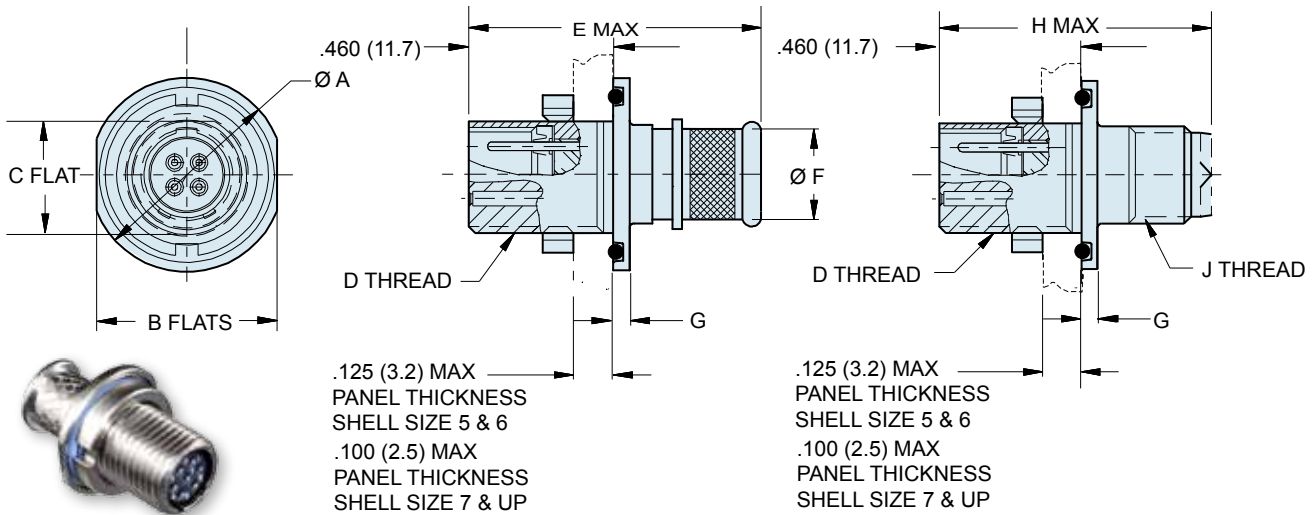

## DIMENSIONS

Shell Size	Ø A		B		C		D Threads Mating	E Max.		Ø F		Ø G		H Max.		J Threads Accessory
	In.	mm.	In.	mm.	In.	mm.		In.	mm.	In.	mm.	In.	mm.	In.	mm.	
5	.541	13.74	.500	12.70	.285	7.24	.3125-28 UN-2A	.875	22.22	.230	5.84	.051	1.30	.850	21.59	.250-32 UNEF-2A
6	.610	15.49	.562	14.27	.352	8.94	.3750-28 UN-2A	.875	22.22	.286	7.26	.051	1.30	.850	21.59	.3125-32 UNEF-2A
7	.670	17.02	.635	16.13	.411	10.44	.4375-28 UNEF-2A	.875	22.22	.390	9.91	.093	2.36	.850	21.59	.4375-28 UNEF-2A
8	.775	19.69	.735	18.67	.473	12.01	.5000-32 UN-2A	.875	22.22	.445	11.30	.093	2.36	.850	21.59	.5000-28 UNEF-2A
9	.875	22.23	.806	20.47	.530	13.46	.5625-32 UN-2A	.875	22.22	.500	12.70	.093	2.36	.850	21.59	.5625-24 UNEF-2A
10	.980	24.89	.940	23.88	.604	15.34	.6250-32 UN-2A	.875	22.22	.565	14.35	.093	2.36	.850	21.59	.6250-24 UNEF-2A
12	1.062	26.97	.986	25.04	.712	18.08	.7500-28 UN-2A	.875	22.22	.650	16.51	.093	2.36	.850	21.59	.6875-24 UNEF-2A

## SERIES 800 PANEL CUTOUTS

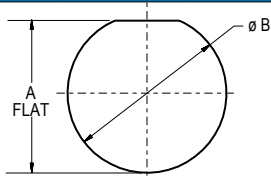

Shell Size	A Flat		Ø B	
	In.	mm.	In.	mm.
5	.295/.299	7.49/7.59	.317/.327	8.05/8.30
6	.358/.362	9.09/9.19	.380/.390	9.65/9.91
7	.424/.428	10.77/10.87	.442/.452	11.23/11.48
8	.479/.483	12.16/12.26	.505/.515	12.83/13.08
9	.537/.541	13.64/13.74	.567/.577	14.40/14.66
10	.610/.614	15.49/15.59	.630/.640	16.00/16.26
12	.717/.721	18.21/18.31	.755/.765	19.18/19.43

## SERIES 800 KEY POSITIONS

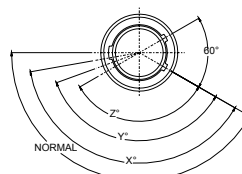

Plug

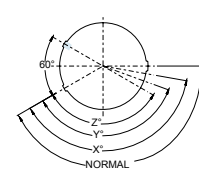

Receptacle

Key Position	Key Rotation
Normal (N)	150°
X	140°
Y	130°
Z	120°

Shell size 5 and 6: master key is located at top dead center for normal (N) position. Shell size 7 thru 12: master key is rotated 90° from TDC.

Dimensions in inches (millimeters) and are subject to change without notice.

© 2010 Glennair, Inc.

CAGE Code 06324

Printed in U.S.A.

**GLENNAIR, INC. • 1211 AIR WAY • GLENDALE, CA 91201-2497 • 818-247-6000 • FAX 818-500-9912**

www.glenair.com

C-8

E-Mail: sales@glenair.com

# Series 800 Mighty Mouse with UN Mating Thread Square Flange Crimp Receptacle Dimensions

800-010-02 and 800-011-02

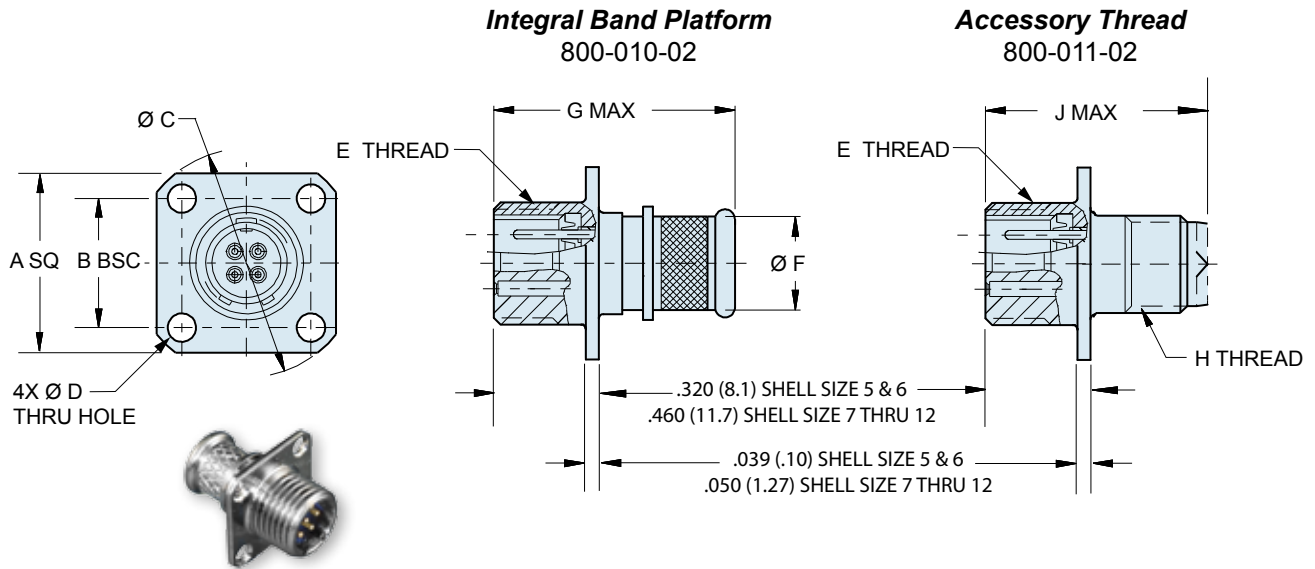

## DIMENSIONS

Shell Size	A SQ		B		Ø C		Ø D		E Threads Mating	Ø F		G Max.		H Threads Accessory	J Max.	
	In.	mm.	In.	mm.	In.	mm.	In.	mm.		In.	mm.	In.	mm.		In.	mm.
5	.527	13.39	.363	9.22	.680	17.27	.094	2.39	.3125-28 UN-2A	.230	5.84	.750	19.05	.250-32 UNEF-2A	.725	18.42
6	.588	14.92	.423	10.74	.750	19.05	.094	2.39	.3750-28 UN-2A	.286	7.26	.750	19.05	.3125-32 UNEF-2A	.725	18.42
7	.650	16.51	.483	12.27	.830	21.08	.128	3.25	.4375-28 UNEF-2A	.390	9.91	.825	20.96	.4375-28 UNEF-2A	.800	20.32
8	.710	18.03	.542	13.77	.938	23.83	.128	3.25	.5000-32 UN-2A	.445	11.30	.825	20.96	.5000-28 UNEF-2A	.800	20.32
9	.938	23.83	.719	18.26	1.250	31.75	.128	3.25	.5625-32 UN-2A	.500	12.70	.825	20.96	.5625-24 UNEF-2A	.800	20.32
10	.938	23.83	.719	18.26	1.250	31.75	.128	3.25	.6250-32 UN-2A	.565	14.35	.825	20.96	.6250-24 UNEF-2A	.800	20.32
12	1.031	26.19	.812	20.62	1.375	34.93	.128	3.25	.7500-28 UN-2A	.650	16.51	.825	20.96	.6875-24 UNEF-2A	.800	20.32

## SERIES 800 KEY POSITIONS

Key Position	Key Rotation		
Normal (N)	150°	<p style="text-align: center;"><b>Plug Key Position</b></p>	<p style="text-align: center;"><b>Receptacle Key Position</b></p>
X	140°		
Y	130°		
Z	120°		
<p>Shell size 5 and 6: master key is located at top dead center for normal (N) position. Shell size 7 thru 12: master key is rotated 90° from TDC.</p>			

Dimensions in inches (millimeters) and are subject to change without notice.

© 2010 Glenair, Inc.

CAGE Code 06324

Printed in U.S.A.

**GLENAIR, INC. • 1211 AIR WAY • GLENDALE, CA 91201-2497 • 818-247-6000 • FAX 818-500-9912**

www.glenair.com

**C-9**

E-Mail: sales@glenair.com

7 - MARCH - 2013



# Series 800 Mighty Mouse with UN Mating Thread In-Line Crimp Receptacle Dimensions 800-010-01 and 800-011-01

**Integral Band Platform**  
800-010-01

**Accessory Thread**  
800-011-01

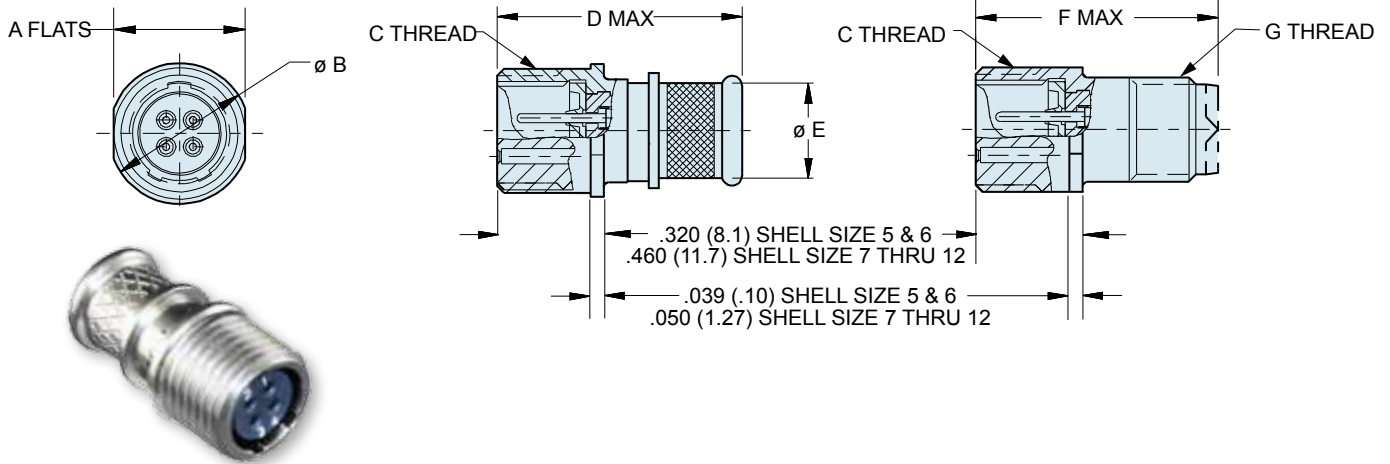

## DIMENSIONS

Shell Size	A		Ø B		C Threads Mating	D Max.		Ø E		F Max.		G Threads Accessory
	In.	mm.	In.	mm.		In.	mm.	In.	mm.			
5	.312	7.92	.355	9.02	.3125-28 UN-2A	.750	19.05	.230	5.84	.725	18.42	.250-32 UNEF-2A
6	.375	9.53	.400	10.16	.3750-28 UN-2A	.750	19.05	.286	7.26	.725	18.42	.3125-32 UNEF-2A
7	.445	11.30	.490	12.45	.4375-28 UNEF-2A	.825	20.96	.390	9.91	.800	20.32	.4375-28 UNEF-2A
8	.550	13.97	.600	15.24	.5000-32 UN-2A	.825	20.96	.445	11.30	.800	20.32	.5000-28 UNEF-2A
9	.613	15.57	.663	16.84	.5625-32 UN-2A	.825	20.96	.500	12.70	.800	20.32	.5625-24 UNEF-2A
10	.675	17.15	.725	18.42	.6250-32 UN-2A	.825	20.96	.565	14.35	.800	20.32	.6250-24 UNEF-2A
12	.800	20.32	.850	21.59	.7500-28 UN-2A	.825	20.96	.650	16.51	.800	20.32	.6875-24 UNEF-2A

## SERIES 800 KEY POSITIONS

Key Position	Key Rotation		
Normal (N)	150°	<p style="text-align: center;"><b>Plug Key Position</b></p>	<p style="text-align: center;"><b>Receptacle Key Position</b></p>
X	140°		
Y	130°		
Z	120°		
<p>Shell size 5 and 6: master key is located at top dead center for normal (N) position. Shell size 7 thru 12: master key is rotated 90° from TDC for normal position.</p>			

Dimensions in inches (millimeters) and are subject to change without notice.  
CAGE Code 06324

Printed in U.S.A.

**GLENAIR, INC. • 1211 AIR WAY • GLENDALE, CA 91201-2497 • 818-247-6000 • FAX 818-500-9912**

www.glenair.com

**C-10**

E-Mail: sales@glenair.com