

WS03DLCX-B

Transient Voltage Suppressor

Features

- 350 Watts Peak Pulse Power per Line ($t_p = 8/20\mu s$)
- Bidirectional Configuration
- Protects One Power or I/O Port
- ESD Protection > 40 kilovolts
- Low Working Voltage: 3.0V
- Low Clamping Voltages
- Ultra Low Capacitance: 1.5 pF Typical



IEC COMPATIBILITY (EN61000-4)

- IEC 61000-4-2 (ESD) $\pm 15kV$ (air), $\pm 8kV$ (contact)
- IEC 61000-4-4 (EFT) 40A (5/50ns)
- IEC 61000-4-5(Surge): 20A, 8/20 μs

Mechanical Characteristics

- Molded JEDEC SOD-323 package
- Weight 10 milligrams (Approximate)
- Flammability rating UL 94V-0
- 8mm Tape and Reel Per EIA Standard 481
- Device Marking: Marking Code
- RoHS/WEEE Compliant

Applications

- Ethernet - 10/100/1000 Base T
- Cellular Phones
- Handheld - Wireless Systems
- Personal Digital Assistant (PDA)
- USB Interface

PIN Configuration

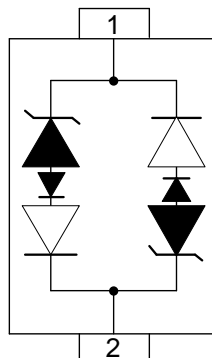

Bidirectional

Absolute Maximum Rating

Rating	Symbol	Value	Units
Peak Pulse Power ($t_p=8/20\mu s$) - See Figure 1	P_{PP}	350	Watts
Peak Pulse Current ($t_p=8/20\mu s$)	I_{PP}	20	A
Operating Temperature	T_J	-55 to + 150	°C
Storage Temperature	T_{STG}	-55 to +150	°C

Electrical Parameters (T=25°C)

Symbol	Parameter
I_{PP}	Maximum Reverse Peak Pulse Current
V_C	Clamping Voltage @ I_{PP}
V_{RWM}	Working Peak Reverse Voltage
I_R	Maximum Reverse Leakage Current @ V_{RWM}
V_{PT}	Punch-through Breakdown Voltage @ I_T
V_{SB}	Snap-Back Voltage @ I_{SB}
I_{SB}	Snap-Back Current
I_{PT}	Test Current
V_{PTF}	Forward Punch-through Breakdown Voltage @ I_F
I_{PTF}	Forward Test Current

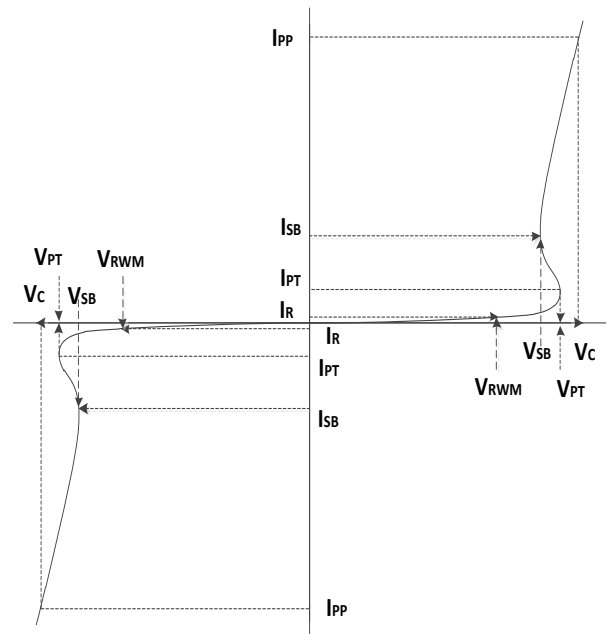

Electrical characteristics

WS03DLCX-B						
Parameter	Symbol	Conditions	Minimum	Typical	Maximum	Units
Reverse Stand-Off Voltage	V_{RWM}	See Note1			3.0	V
Punch-through Voltage	V_{PT}	$I_{PT}=1\mu A$	4.0			V
Snap-Back Voltage	V_{SB}	$I_{SB}=50mA$	3.5			V
Reverse Leakage Current	I_R	$V_{RWM}=3.0V$			1	μA
Clamping Voltage	V_C	$I_{PP} = 1A, t_p = 8/20\mu s$		4.8	5.1	V
Clamping Voltage	V_C	$I_{PP} = 20A, t_p = 8/20\mu s$		15	18	V
Junction Capacitance	C_j	$V_R = 0V, f = 1MHz$		1.5	3.0	pF

Note 1: Part numbers with an additional “B” suffix are bidirectional devices

Note 2: For Bidirectional Devices Only: Electrical characteristics apply in both directions.

Typical Characteristics

Figure 1: Peak Pulse Power vs. Pulse Time

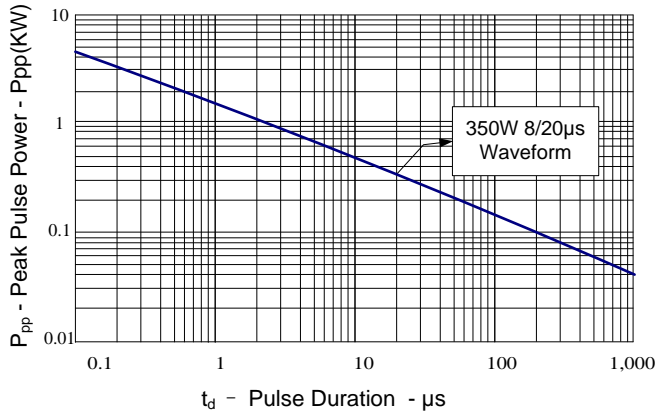

Figure 2: Power Derating Curve

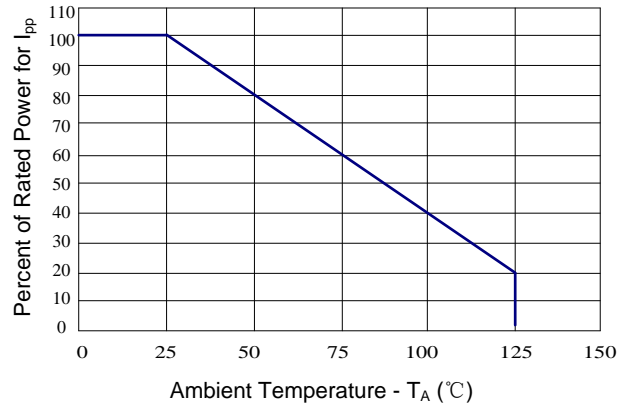

Figure 3: Clamping Voltage vs. Peak Pulse Current

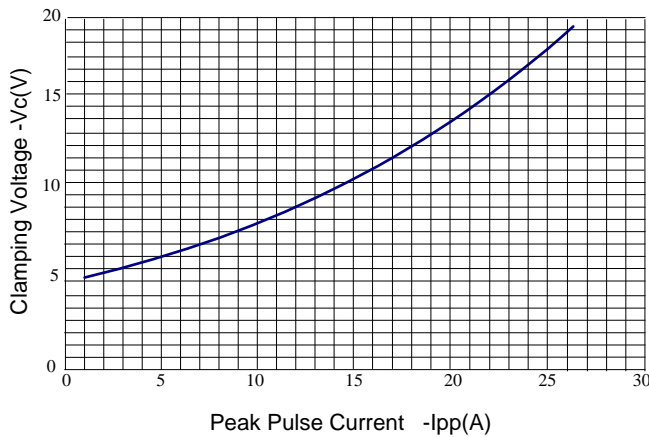

Figure 4: Normalized Junction Capacitance vs. Reverse Voltage

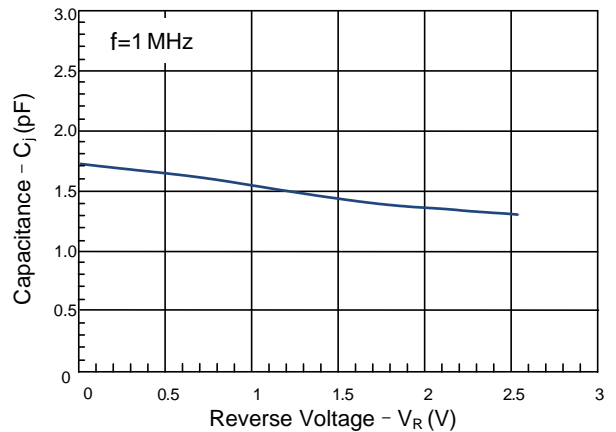

Figure 5: ESD Clamping(8kV Contact per IEC 61000-4-2)

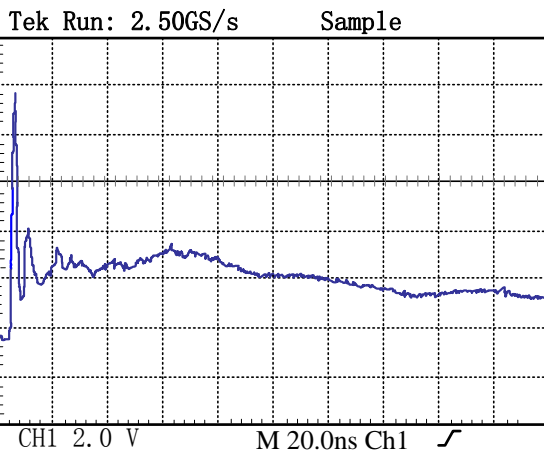
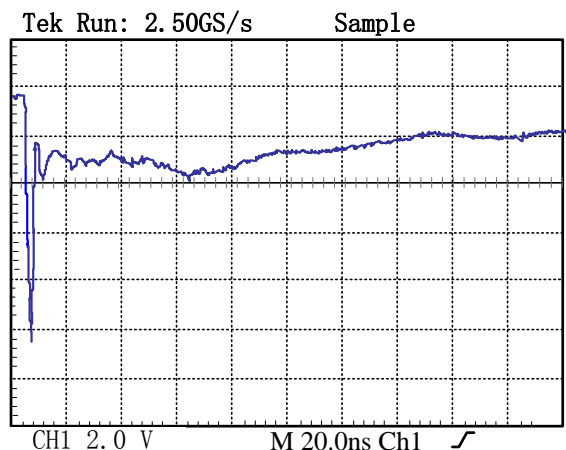
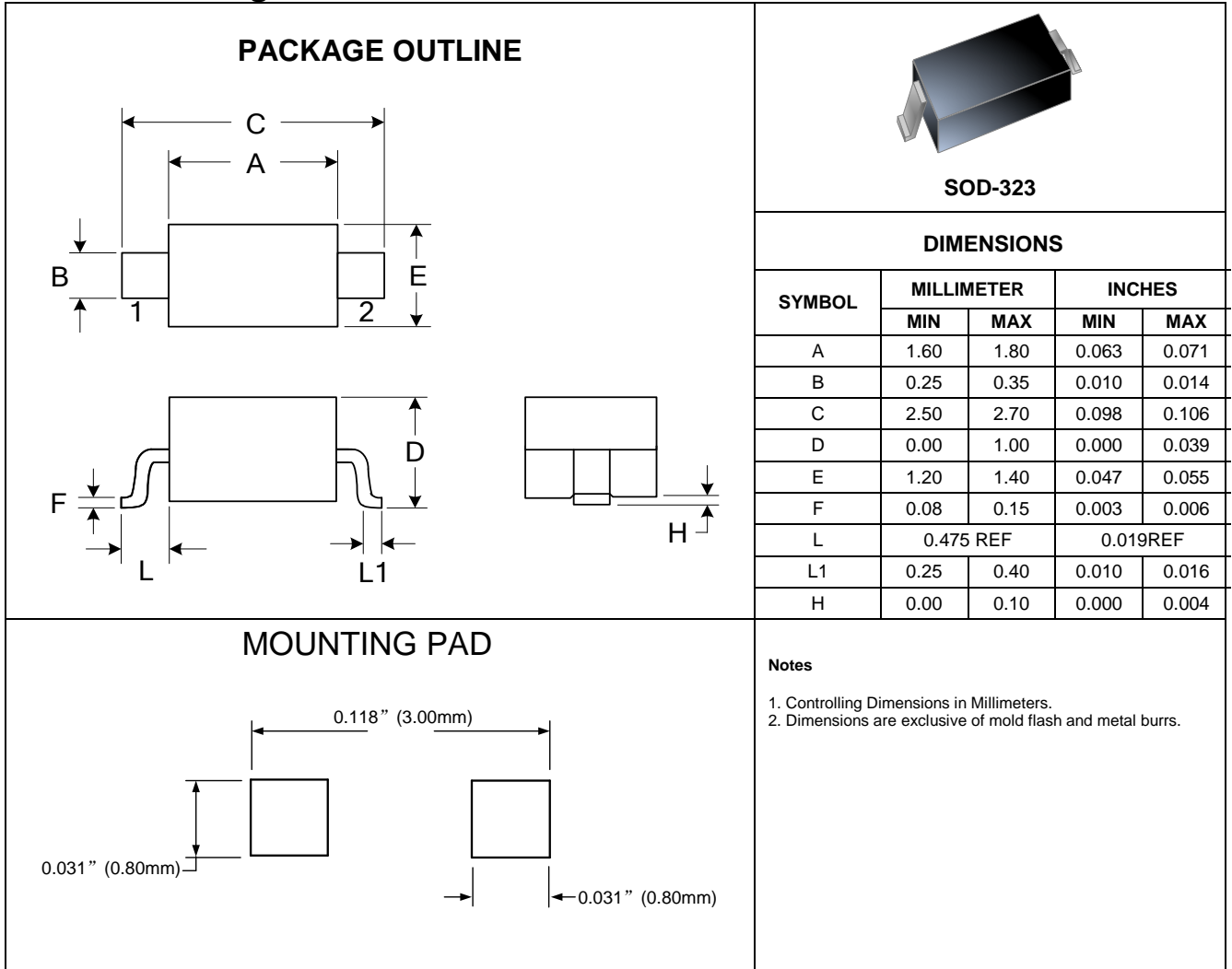

Figure 5: ESD Clamping(-8kV Contact per IEC 61000-4-2)



Outline Drawing – SOD323



Marking Codes

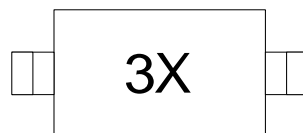

CONTACT INFORMATION

SHANGHAI CHANGYUAN WAYON CIRCUIT PROTECTION CO., LTD.
 No.1001, Shiwan(7) Road, Pudong District, Shanghai, P.R.China.201202
 Tel: 86 21-68969995, Fax: 86 21-68969990, Website: www.way-on.com
 For additional information, please contact your local Sales Representative.



® is registered trademark of CHANGYUAN WAYON Corporation.

Wayon reserves the right to change or uprate, without notice, any information contained in this specification.