

## GLASS PASSIVATED BRIDGE RECTIFIERS

REVERSE VOLTAGE - 50 to 1000Volts  
FORWARD CURRENT - 6.0 Amperes

### FEATURES

- Surge overload rating -175 amperes peak
- Ideal for printed circuit board
- Reliable low cost construction utilizing molded plastic technique
- Plastic material has U/L flammability classification 94V-0
- Mounting position:Any

### GBU

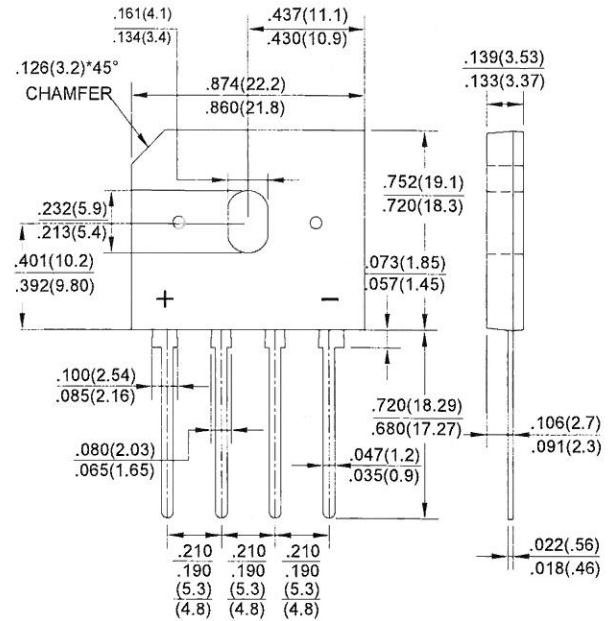

### MAXIMUM RATINGS AND ELECTRICAL CHARACTERISTICS

Rating at 25°C ambient temperature unless otherwise specified.

Single phase, half wave ,60Hz, resistive or inductive load.

For capacitive load, derate current by 20%

CHARACTERISTICS	SYMBOL	GBU6005	GBU601	GBU602	GBU604	GBU606	GBU608	GBU610	UNIT	
Maximum Recurrent Peak Reverse Voltage	V <sub>RRM</sub>	50	100	200	400	600	800	1000	V	
Maximum RMS Voltage	V <sub>RMS</sub>	35	70	140	280	420	560	700	V	
Maximum DC Blocking Voltage	V <sub>DC</sub>	50	100	200	400	600	800	1000	V	
Maximum Average Forward Rectified Current @ T <sub>c</sub> =100°C (without heatsink)	I <sub>(AV)</sub>	6.0								A
Peak Forward Surge Current 8.3ms Single Half Sine-Wave Super Imposed on Rated Load (JEDEC Method)	I <sub>FSM</sub>	175								A
Maximum Forward Voltage at 3.0A DC	V <sub>F</sub>	1.0								V
Maximum DC Reverse Current at Rated DC Blocking Voltage @ T <sub>J</sub> =25°C	I <sub>R</sub>	10.0								μA
Maximum DC Reverse Current at Rated DC Blocking Voltage @ T <sub>J</sub> =125°C	I <sub>R</sub>	500								μA
I <sup>2</sup> t Rating for Fusing (t<8.3ms)	I <sup>2</sup> t	127								A <sup>2</sup> s
Typical Junction Capacitance Per Element (Note1)	C <sub>J</sub>	50								pF
Typical Thermal Resistance	R <sub>θJC</sub>	2.2								°C/W
Operating Temperature Range	T <sub>J</sub>	-55 to +150								°C
Storage Temperature Range	T <sub>STG</sub>	-55 to +150								°C

NOTES: 1. Measured at 1.0MHz and applied reverse voltage of 4.0V DC.

2. Device mounted on 75mm\*75mm\*1.6mm Cu plate heatsink.

3. The typical data above is for reference only(典型值仅供参考).

FIG.1-FORWARD CURRENT DERATING CURVE

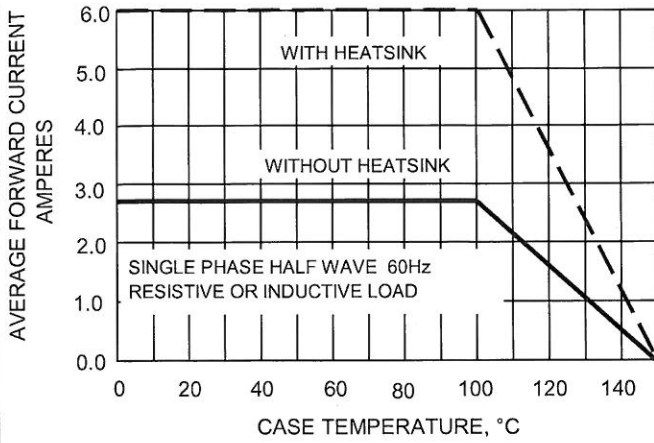

FIG.2-MAXIMUM NON-REPETITIVE SURGE CURRENT

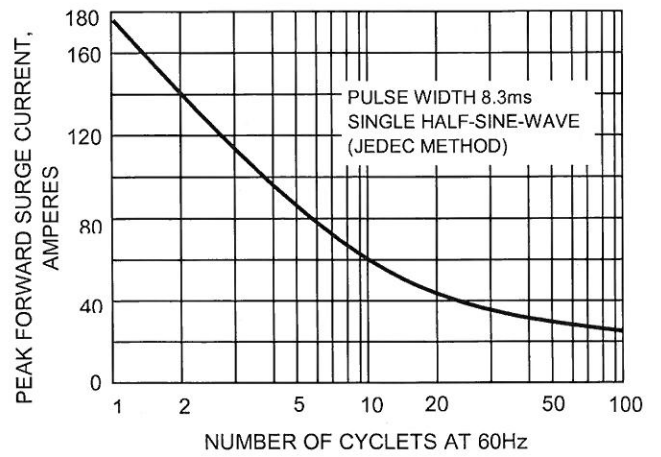

FIG.3-TYPICAL JUNCTION CAPACITANCE

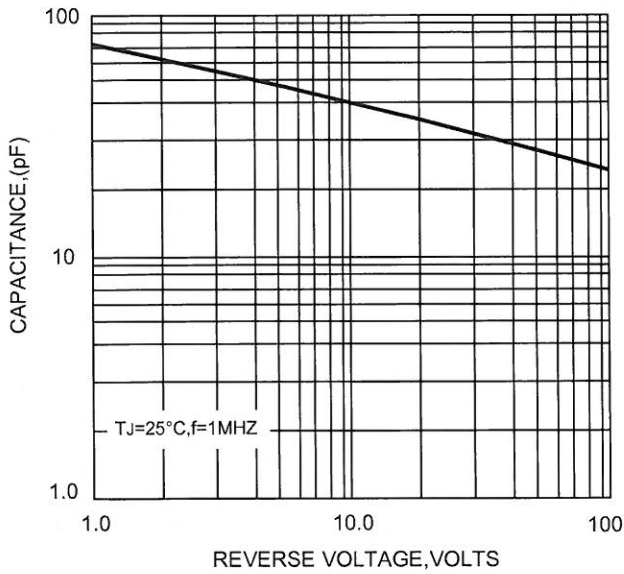

FIG.4-TYPICAL FORWARD CHARACTERISTICS

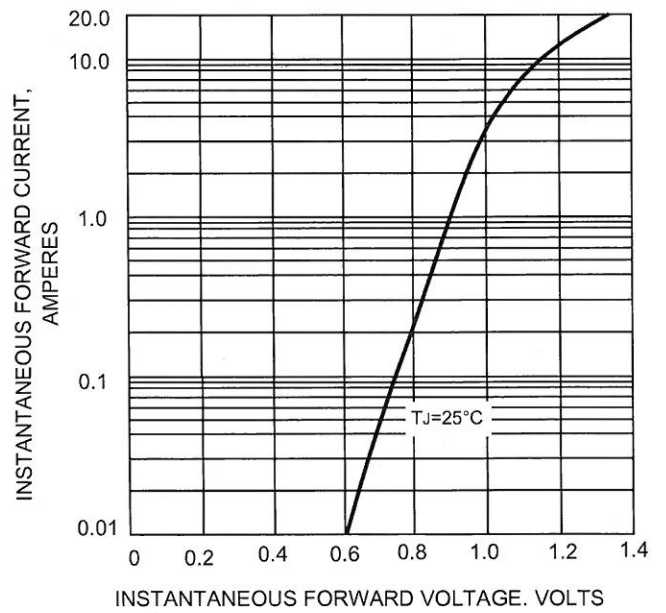
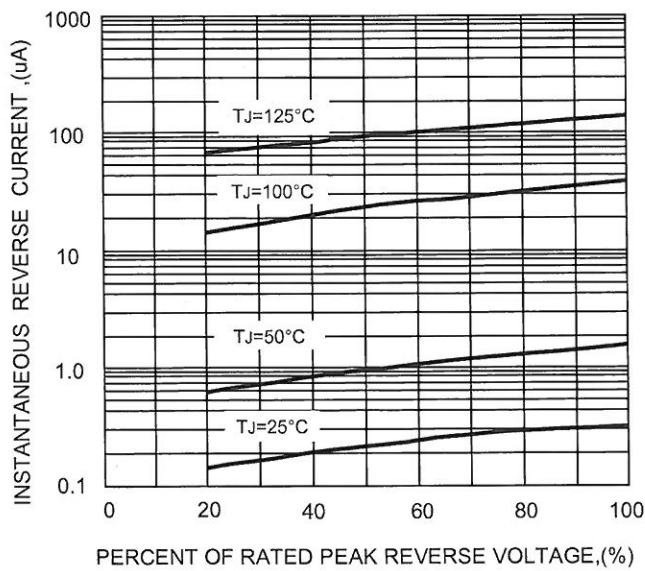

FIG.5-TYPICAL REVERSE CHARACTERISTICS



The cruve graph is for reference only, can't be the basis for judgment(曲线图仅供参考!)