

**PRODUCT NUMBER: 110-43-624-41-001000**

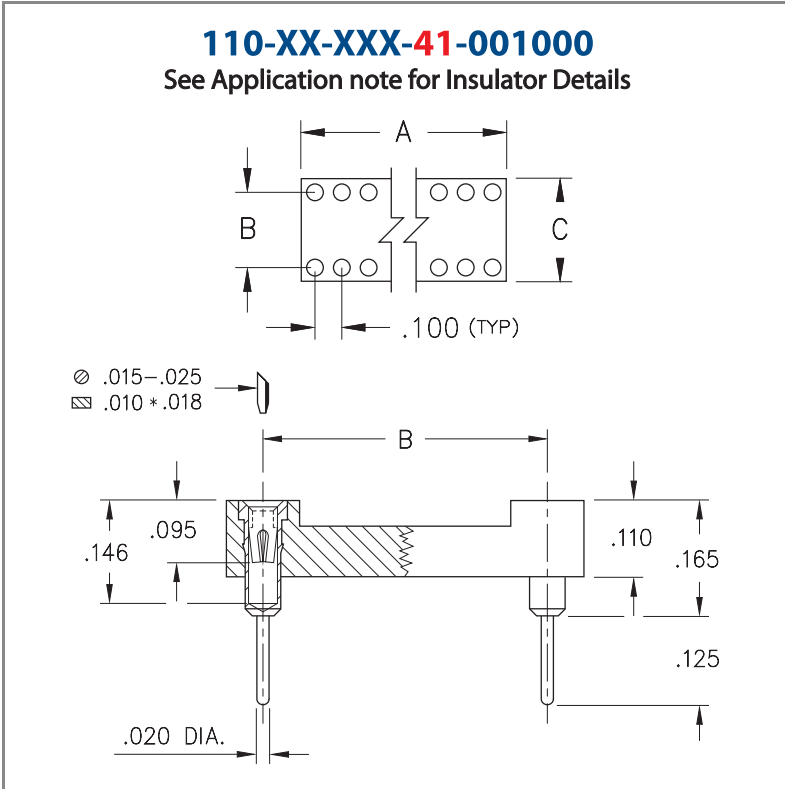

**DESCRIPTION**

DIP Dual In Line Socket  
 Standard Solder Tail  
**Frame Type:** Open Frame  
**Pitch:** .100" (2,540mm)  
**Clip Grid:** 41  
**Pin Window Pattern** 001  
**Plating Code:** 43  
**Shell:** 200  $\mu$ " Tin (matte finish) over 100  $\mu$ " Nickel  
**Inner Contact:** 30  $\mu$ " Gold over 50  $\mu$ " Nickel  
**Insulator Pin Clip Type:** 000  
**Mounting Type:** Through Hole Solder Mount  
**Packaging:** Packaged in Tubes  
**Insulator Information:**  
 PCT High Temperature

# Pins	Qty Tube	ROHS Compliant	A Dim	B Dim	C Dim
24	16		1.200" (30,480mm)	.600" (15,240mm)	.700" (17,780mm)

**CONTACT:**

**#30 CONTACT**  
 FOR .015"-.025" DIAMETER PINS ( $\delta = .005$ )  
 4-FINGER, GROUP C (See page 248)

**CONTACT MATERIAL**  
 BERYLLIUM COPPER Alloy 172, Heat Treated

<b>Pin Diameter Range</b>	.015"-.025" (0,381-0,635mm)		
<b>Material</b>	Beryllium Copper	<b>Current Rating (amps)</b>	3.00
<b>Fingers</b>	4	<b>Compliance</b>	.005" (0,127mm)
<b>Length</b>	.080" (2,032mm)	<b>Group Code</b>	C

## CONTACT MATERIAL:

### BERYLLIUM COPPER ALLOY 172 (UNS C17200) per ASTM B 194

Properties of BERYLLIUM COPPER:

- Chemical composition: Cu 98.1%, Be 1.9%
- Hardness: 36-43 Rockwell C
- Density: .298 lbs/in<sup>3</sup>
- Electrical Conductivity: 22% IACS\*
- Resistance: 10 mΩ Max
- Operating Temperature: -55°C/+125°C
- Melting point: 980°C/865°C (liquidus/solidus)
- Stress Relaxation†: 96% of stress remains after 1,000 hours @ 100 °C; 70% of stress remains after 1,000 hours @ 200 °C

\*International Annealed Copper Standard, i.e. as a % of pure copper.

†Since BeCu loses its spring properties over time at high temperatures; it is rated for continuous use up to 150 °C. For applications up to 300 °C, Mill-Max offers other materials. [Contact Tech Support](#) for more info.

## LOOSE PIN/RECEPTACLE USED:

1001 (Brass Alloy)

### BRASS ALLOY 360 per ASTM B 16, or 385 per ASTM B455

Properties of BRASS ALLOY 360 ASTM B 16:

- Chemical composition: Cu 63% (max), Pb 3.7% (max)†, Fe .35% (max), Zn remainder
- Temper as machined: H02/H04
- Yield Strength: 25-45 ksi
- Tensile strength: 57-80 ksi
- Hardness as machined: 80-90 Rockwell B
- Electrical conductivity: 26% IACS\*
- Melting point: 1000°C/840°C (liquidus/solidus)

Properties of BRASS ALLOY 385 ASTM B 455:

- Chemical composition: Cu 60% (max), Pb 3.5% (max)†, Fe .35% (max), Zn remainder
- Temper as machined: H02/H04
- Yield Strength: 16 ksi(min)
- Tensile strength: 48 ksi(min)
- Hardness as machined: 80-90 Rockwell B
- Electrical conductivity: 28% IACS\*
- Melting point: 1000°C/840°C (liquidus/solidus)

After machining, brass parts are often annealed (softened) for subsequent bending, swaging or crimping. A partial anneal down to 60±10 RB is recommended for 90° bends, a full anneal down to 35±15 RB is recommended for pins or terminals that are swaged (riveted) to a circuit board or crimped to a wire.

**Note:** Plated Brass parts need a barrier plate to prevent zinc diffusion, 50µ" min. nickel or 100µ" min. copper is recommended by ASTM B 545 and 579. ASTM B 488 also recommends a 50µ" min. nickel barrier plate beneath gold to prevent copper diffusion inherent with all copper alloy products.

†RoHS-2 directive 2011/65/EU, exemption 6c allows up to 4% lead as an alloy agent in copper.

\*International Annealed Copper Standard, i.e. as a % of pure copper.

## INSULATOR MATERIAL:

### PCT Polyester (Injection Molded)

Properties:

- Polyester (30% glass filled), High Temp., (black). Flammability rating UL 94 V-0
- Rated voltage: 100 VRMS/150 VDC
- Insulation resistance: 10,000 Megaohms min.
- Material Heat Deflection Temp (per ASTM D 648): 529°F (276°C) @ 66 psi
- Dielectric strength: 1000 VRMS min. (700 VRMS min. for series 117 Shrink DIP)

Note: Materials with HDT above 446°F (230°C) are considered suitable for “eutectic” reflow soldering. For “lead-free” reflow soldering, choose materials with an HDT above 500°F (260°C). PCT is the standard plastic used with RoHS “lead-free” plated pins.

## ADDITIONAL NOTES & SPECIFICATIONS

In the interest of improved design, quality and performance, Mill-Max reserves the right to make changes in its specifications without prior notice. Specifications and tolerances are provided wherever possible. Due to the wide variety of interconnects Mill-Max offers, the specific tolerances vary from product to product. If you need information regarding the tolerance of a particular part, please contact Technical Services.

---

 © 2020 Mill-Max Mfg. Corp.  
190 Pine Hollow Rd , Oyster Bay, NY 11771, USA  
Phone: 516.922.6000