

Serial SPI bus real-time clock (RTC) with battery switchover

Datasheet - production data

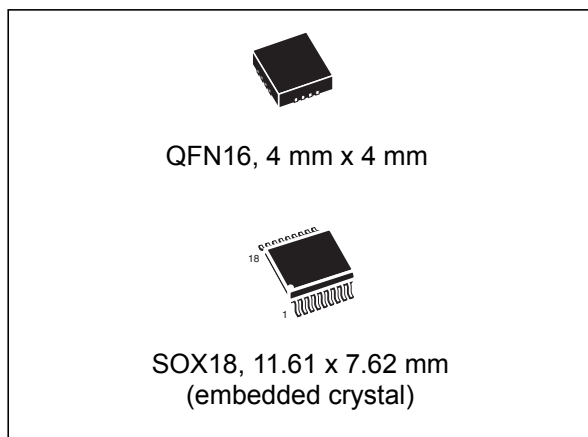

- Programmable 8-bit counter/timer
- 7 bytes of battery-backed user SRAM
- Battery low flag
- Low operating current of 80 μ A
- Oscillator stop detection
- Battery or supercapacitor backup
- Operating temperature of -40 °C to $+85$ °C
- Package options include a 16-lead QFN and an 18-lead embedded crystal SOIC

Features

- Ultra-low battery supply current of 365 nA
- Factory calibrated accuracy ± 5 ppm typical after 2 reflows (SOX18) (much better accuracies are achievable using built-in programmable analog and digital calibration circuits)
- 2.0 V to 5.5 V clock operating voltage
- Counters for tenths/hundredths of seconds, seconds, minutes, hours, day, date, month, year, and century
- Automatic switchover and reset output circuitry (fixed reference):
M41T93S: $V_{CC} = 3.0$ V to 5.5 V;
M41T93R: $V_{CC} = 2.7$ V to 5.5 V;
M41T93Z: $V_{CC} = 2.38$ V to 5.50 V
- Compatible with SPI bus serial interface (supports SPI mode 0 [CPOL = 0, CPHA = 0])
- Programmable alarm with interrupt function (valid even during battery backup mode)
- Optional 2nd programmable alarm available
- Square wave output (defaults to 32 KHz on power-up)
- RESET (\overline{RST}) output
- Watchdog timer

Contents

1	Description	6
1.1	SPI signal description	11
1.1.1	Serial data output (SDO)	11
1.1.2	Serial data input (SDI)	11
1.1.3	Serial clock (SCL)	11
1.1.4	Chip enable (E)	11
2	Operation	12
2.1	SPI bus characteristics	12
2.2	READ and WRITE cycles	13
2.3	Data retention and battery switchover ($V_{SO} = V_{RST}$)	15
2.4	Power-on reset (t_{rec})	15
3	Clock operation	16
3.1	Clock data coherency	17
3.1.1	Example of incoherency	17
3.1.2	Accessing the device	18
3.2	Halt bit (HT) operation	18
3.2.1	Power-down time stamp	19
3.3	Real-time clock accuracy	21
3.4	Clock calibration	22
3.4.1	Digital calibration (periodic counter correction)	22
3.4.2	Analog calibration (programmable load capacitance)	25
3.4.3	Pre-programmed calibration value	26
3.5	Setting the alarm clock registers	30
3.6	Optional second programmable alarm	31
3.7	Watchdog timer	31
3.8	8-bit (countdown) timer	32
3.8.1	Timer interrupt/output	32
3.8.2	Timer flag (TF)	34
3.8.3	Timer interrupt enable (TIE)	34
3.8.4	Timer enable (TE)	34
3.8.5	TD1/0	34

3.9	Square wave output	35
3.10	Battery low warning	36
3.11	Century bits	37
3.12	Oscillator fail detection	38
3.13	Oscillator fail interrupt enable	38
3.14	$\overline{\text{IRQ}}/\text{FT}/\text{OUT}$ pin, frequency test, interrupts and the OUT bit	38
	3.14.1 Active mode operation on V_{CC}	40
	3.14.2 Backup mode	41
3.15	Initial power-on defaults	42
3.16	OTP bit operation (SOX18 package only)	42
4	Maximum ratings	43
5	DC and AC parameters	44
6	Package mechanical data	50
7	Part numbering	54
8	Revision history	55

List of tables

Table 1.	Signal names	7
Table 2.	Function table	10
Table 3.	Clock/control register map (32 bytes)	20
Table 4.	Digital calibration values	24
Table 5.	Analog calibration values	26
Table 6.	Alarm repeat modes	31
Table 7.	Timer control register map	33
Table 8.	Timer interrupt operation in free-running mode (with $\overline{TI}/TP = 1$)	33
Table 9.	Timer source clock frequency selection (244.1 μ s to 4.25 hrs)	34
Table 10.	Square wave output frequency	35
Table 11.	Priority for $\overline{IRQ}/FT/OUT$ pin when operating on V_{CC}	40
Table 12.	Priority for $\overline{IRQ}/FT/OUT$ pin when operating in backup mode	41
Table 13.	Initial power-on default values (part 1)	42
Table 14.	Initial power-up default values (part 2)	42
Table 15.	Absolute maximum ratings	43
Table 16.	Operating and AC measurement conditions	44
Table 17.	Capacitance	44
Table 18.	DC characteristics	45
Table 19.	Crystal electrical characteristics	46
Table 20.	Oscillator characteristics	46
Table 21.	Power down/up trip points DC characteristics	47
Table 22.	AC characteristics	49
Table 23.	QFN16 – 16-lead, quad, flat package, no lead, 4 x 4 mm body, mech. data	51
Table 24.	SOX18 – 18-lead plastic SO, 300 mils, embedded crystal, pkg. mech. data	53
Table 25.	Ordering information	54
Table 26.	Document revision history	55

List of figures

Figure 1.	Logic diagram	7
Figure 2.	QFN16 connections	8
Figure 3.	SOX18 connections	8
Figure 4.	Block diagram	9
Figure 5.	Hardware hookup	10
Figure 6.	Data and clock timing	10
Figure 7.	READ mode sequence	14
Figure 8.	WRITE mode sequence	14
Figure 9.	Clock data coherency	17
Figure 10.	Internal load capacitance adjustment	21
Figure 11.	Crystal accuracy across temperature	26
Figure 12.	Clock accuracy vs. on-chip load capacitors	28
Figure 13.	Clock divider chain and calibration circuits	29
Figure 14.	Crystal isolation example	30
Figure 15.	Backup mode alarm waveform	31
Figure 16.	Timer output waveform in free-running mode (with $\overline{TI}/TP = 1$)	33
Figure 17.	Battery check	36
Figure 18.	Two-bit binary counter (century bits CB1:CB0).	37
Figure 19.	$\overline{IRQ}/FT/OUT$ output pin circuit	39
Figure 20.	Measurement AC I/O waveform	44
Figure 21.	I_{CC2} vs. temperature	46
Figure 22.	Power down/up mode AC waveforms	47
Figure 23.	Input timing requirements	48
Figure 24.	Output timing requirements	48
Figure 25.	QFN16 – 16-lead, quad, flat package, no lead, 4 x 4 mm body size, outline	51
Figure 26.	QFN16 – 16-lead, quad, flat, no lead, 4 x 4 mm, recommended footprint	52
Figure 27.	32 KHz crystal + QFN16 vs. VSOJ20 mechanical data	52
Figure 28.	SOX18 – 18-lead plastic small outline, 300 mils, embedded crystal	53

1 Description

The M41T93 is a low-power serial SPI bus real-time clock (RTC) with a built-in 32.768 kHz oscillator (external crystal-controlled for the QFN16 package, and embedded crystal for the SOX18 package). Eight bytes of the register map are used for the clock/calendar function and are configured in binary coded decimal (BCD) format. An additional 17 bytes of the register map provide status/control of the two alarms, watchdog, 8-bit counter, and square wave functions. An additional seven bytes are made available as user SRAM.

Addresses and data are transferred serially via a serial SPI bus-compatible interface. The built-in address register is incremented automatically after each WRITE or READ data byte. The M41T93 has a built-in power sense circuit which detects power failures and automatically switches to the battery supply when a power failure occurs. The energy needed to sustain the clock operations can be supplied by a small lithium button battery when a power failure occurs.

Functions available to the user include a non-volatile, time-of-day clock/calendar, alarm interrupt, watchdog timer, programmable 8-bit counter, and square wave outputs. The eight clock address locations contain the century, year, month, date, day, hour, minute, second, and tenths/hundredths of a second in 24-hour BCD format. Corrections for 28, 29 (leap year), 30, and 31 day months are made automatically. The M41T93 is supplied in either a QFN16 or an SOX18, 300 mil SOIC which includes an embedded 32 KHz crystal. The SOX18 package requires only a user-supplied battery to provide non-volatile operation.

Figure 1. Logic diagram

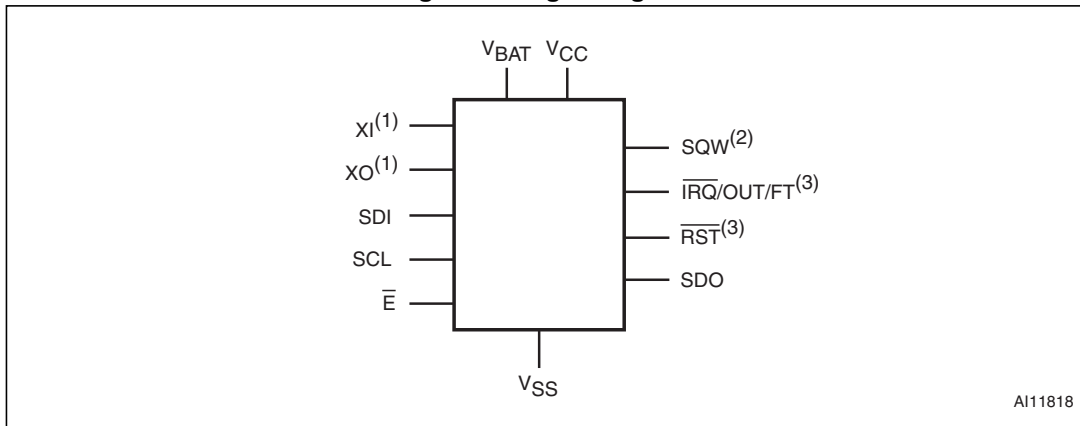

AI11818

1. For QFN16 package only
2. Defaults to 32 KHz on power-up
3. Open drain

Table 1. Signal names

Symbol	Description
XI ⁽¹⁾	32 KHz oscillator input
XO ⁽¹⁾	32 KHz oscillator output
$\overline{IRQ/FT/OUT}$	Interrupt/frequency test/output driver (open drain)
SQW ⁽²⁾	32 KHz programmable square wave output
\overline{RST}	Power-on reset output (open drain)
\bar{E}	Chip enable
SDI	Serial data address input
SDO	Serial data address output
SCL	Serial clock input
V _{BAT}	Battery supply voltage (tie V _{BAT} to V _{SS} if no battery is connected)
DU ⁽³⁾	Do not use
V _{CC}	Supply voltage
V _{SS}	Ground

1. For QFN16 package only
2. Defaults to 32 KHz on power-up
3. Do not use (must be tied to V_{CC})

Figure 2. QFN16 connections

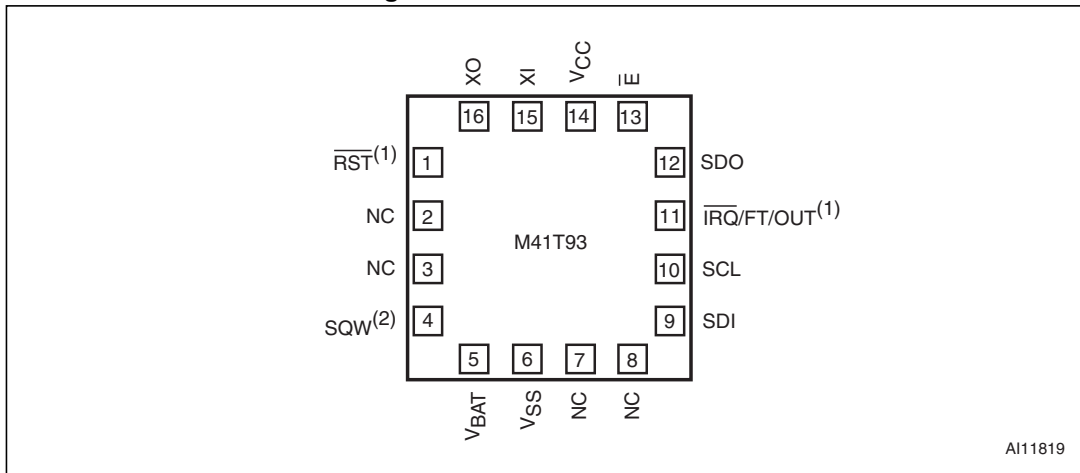

AI11819

1. Open drain output
2. Defaults to 32 KHz on power-up

Figure 3. SOX18 connections

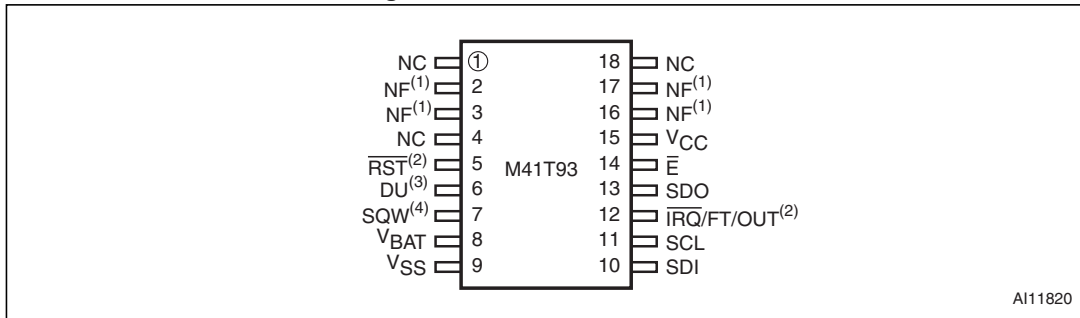

AI11820

1. NF pins must be tied to V_{SS}. Pins 2 and 3, and 16 and 17 are internally shorted together.
2. Open drain output
3. Do not use (must be tied to V_{CC})
4. Defaults to 32 KHz on power-up

Figure 4. Block diagram

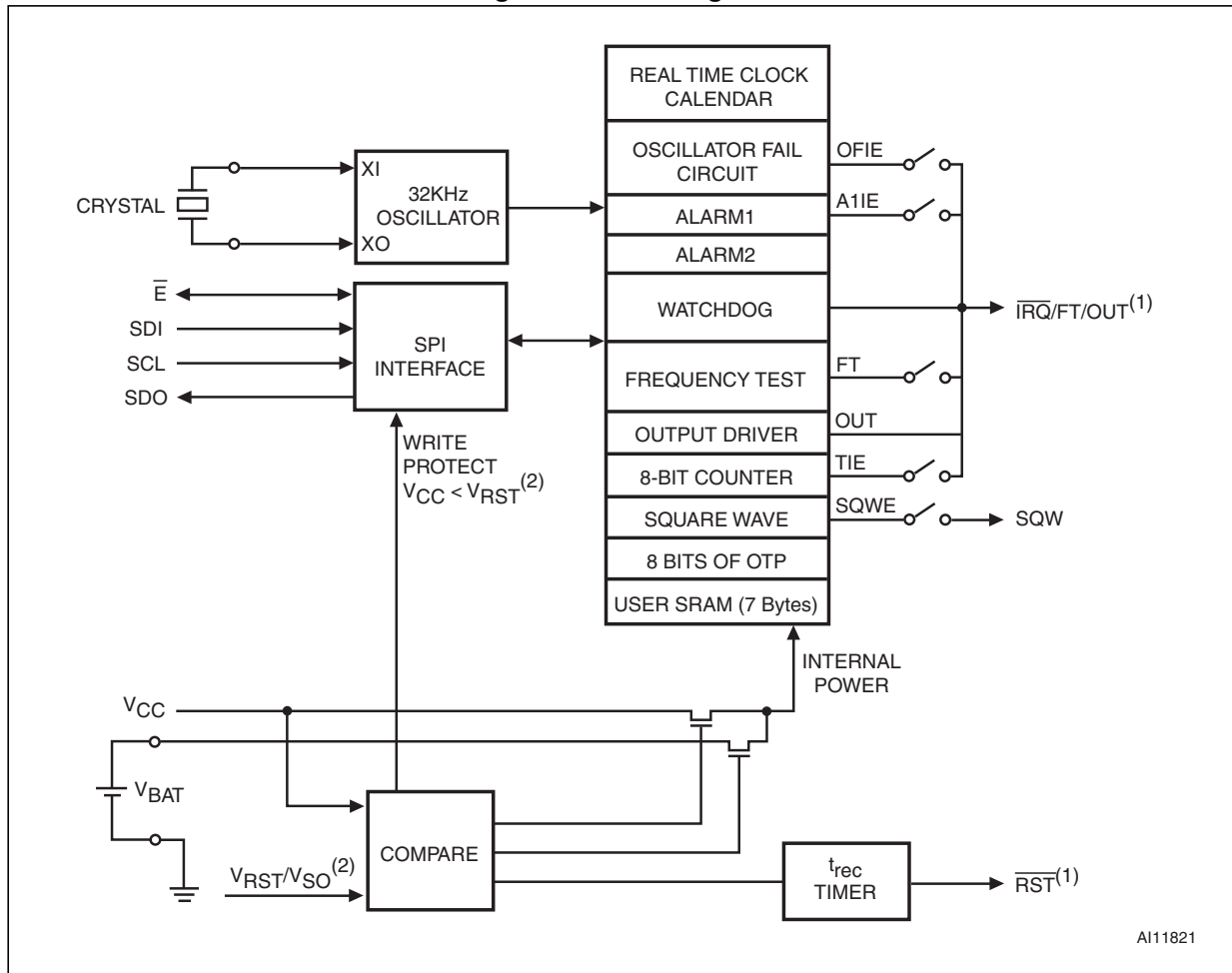

1. Open drain output
2. $V_{RST} = V_{SO} = 2.93 \text{ V (S)}, 2.63 \text{ V (R)}, \text{ and } 2.32 \text{ V (Z)}$

Figure 5. Hardware hookup

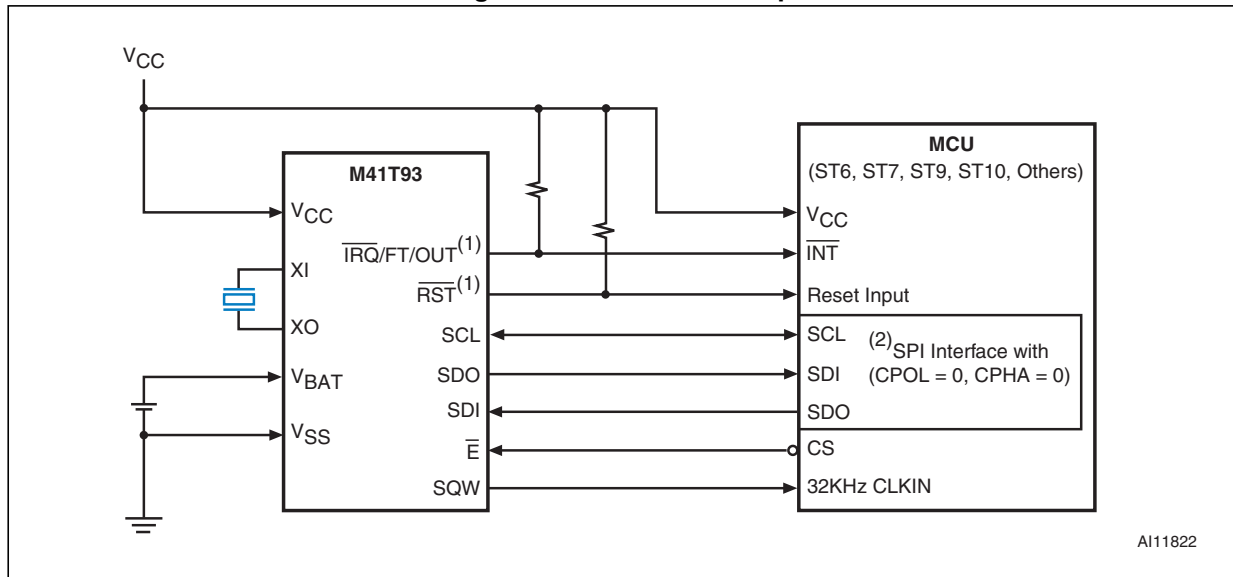

1. Open drain output
2. CPOL (clock polarity) and CPHA (clock phase) are bits that may be set in the SPI control register of the MCU.

Table 2. Function table

Mode	E	SCL	SDI	SDO
Disable reset	H	Input disabled	Input disabled	High Z
WRITE	L		Data bit latch	High Z
READ	L		X	Next data bit shift ⁽¹⁾

1. SDO remains at High Z until eight bits of data are ready to be shifted out during a READ.

Figure 6. Data and clock timing

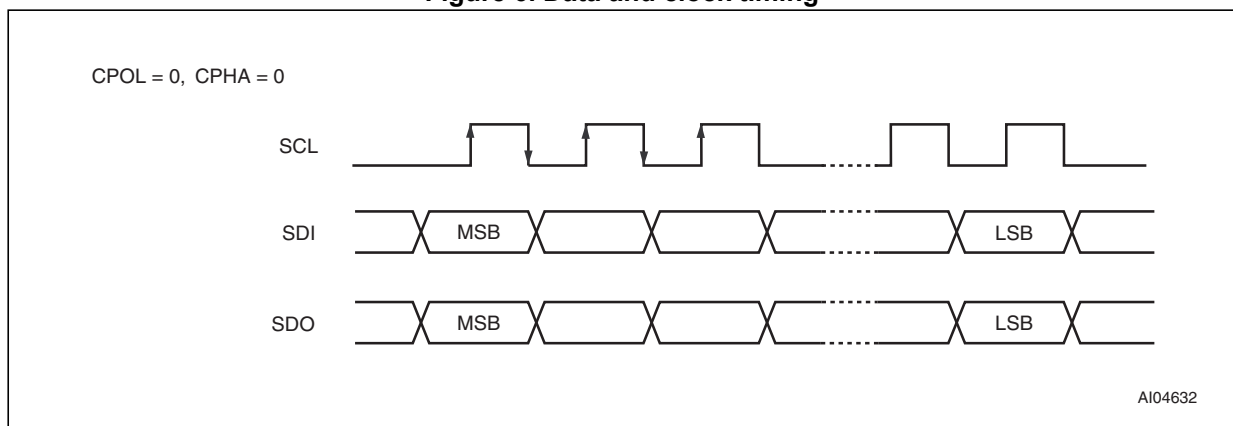

Note: Supports SPI mode 0 (CPOL = 0, CPHA = 0) only.

1.1 SPI signal description

1.1.1 Serial data output (SDO)

The output pin is used to transfer data serially out of the device. Data is shifted out on the falling edge of the serial clock.

1.1.2 Serial data input (SDI)

The input pin is used to transfer data serially into the device. Instructions, addresses, and the data to be written, are each received this way. Input is latched on the rising edge of the serial clock.

1.1.3 Serial clock (SCL)

The serial clock provides the timing for the serial interface (as shown in [Figure 23 on page 48](#) and [Figure 24 on page 48](#)). The W/R bit, addresses, or data are latched, from the input pin, on the rising edge of the clock input. The output data on the SDO pin changes state after the falling edge of the clock input.

The M41T93 can be driven by a microcontroller with its SPI peripheral running in only mode 0: (CPOL, CPHA) = (0,0).

For this mode, input data (SDI) is latched in by the low-to-high transition of clock SCL, and output data (SDO) is shifted out on the high-to-low transition of SCL (see [Table 2 on page 10](#) and [Figure 6 on page 10](#)).

1.1.4 Chip enable (\bar{E})

When \bar{E} is high, the memory device is deselected, and the SDO output pin is held in its high impedance state.

After power-on, a high-to-low transition on \bar{E} is required prior to the start of any operation.

2 Operation

The M41T93 clock operates as a slave device on the SPI serial bus. It is accessed by a simple serial interface that is SPI bus-compatible. The bus signals are SCL, SDI, SDO, and \bar{E} (see [Table 1 on page 7](#) and [Figure 5 on page 10](#)). The device is selected when the chip enable input (\bar{E}) is held low. All instructions, addresses and data are shifted serially in and out of the chip. The most significant bit is presented first, with the data input (SDI) sampled on the first rising edge of the clock (SCL) after the chip enable (\bar{E}) goes low. The 32 bytes contained in the device can then be accessed sequentially in the following order:

- 1st byte: tenths/hundredths of a second register
- 2nd byte: seconds register
- 3rd byte: minutes register
- 4th byte: century/hours register
- 5th byte: day register
- 6th byte: date register
- 7th byte: month register
- 8th byte: year register
- 9th byte: digital calibration register
- 10th byte: watchdog register
- 11th - 15th bytes: alarm 1 registers
- 16th byte: flags register
- 17th byte: timer value register
- 18th byte: timer control register
- 19th byte: analog calibration register
- 20th byte: square wave register
- 21st - 25th bytes: alarm 2 registers
- 26th - 32nd bytes: user RAM

The M41T93 clock continually monitors V_{CC} for an out-of-tolerance condition. Should V_{CC} fall below V_{RST} , the device terminates any access in progress and resets the device address counter. Inputs to the device will not be recognized at this time to prevent erroneous data from being written to the device from an out-of-tolerance system.

The power input will also be switched from the V_{CC} pin to the external battery when V_{CC} falls below the battery back-up switchover voltage ($V_{SO} = V_{RST}$). At this time the clock registers will be maintained by the battery supply. As system power returns and V_{CC} rises above V_{SO} , the battery is disconnected, and the power supply is switched to external V_{CC} .

The device remains write protected until t_{REC} seconds elapse after V_{CC} rises above V_{PFD} (min). For more information on battery storage life refer to application note AN1012.

2.1 SPI bus characteristics

The serial peripheral interface (SPI) bus is intended for synchronous communication between different ICs. It consists of four signal lines: serial data input (SDI), serial data output (SDO), serial clock (SCL) and a chip enable (\bar{E}).

By definition a device that gives out a message is called “transmitter,” the receiving device that gets the message is called “receiver.” The device that controls the message is called “master.” The devices that are controlled by the master are called “slaves.”

The \bar{E} input is used to initiate and terminate a data transfer. The SCL input is used to synchronize data transfer between the master (micro) and the slave (M41T93) device.

The SCL input, which is generated by the microcontroller, is active only during address and data transfer to any device on the SPI bus (see [Figure 5 on page 10](#)).

The M41T93 can be driven by a microcontroller with its SPI peripheral running in only mode 0: (CPOL, CPHA) = (0,0).

For this mode, input data (SDI) is latched in by the low-to-high transition of clock SCL, and output data (SDO) is shifted out on the high-to-low transition of SCL (see [Table 2](#) and [Figure 6 on page 10](#)).

There is one clock for each bit transferred. Address and data bits are transferred in groups of eight bits. Since only 32 addresses are required, address bit 6 is a “don’t care”.

2.2 READ and WRITE cycles

Address and data are shifted MSB first into the serial data input (SDI) and out of the serial data output (SDO). Any data transfer considers the first bit to define whether a READ or WRITE will occur. This is followed by seven bits defining the address to be read or written. Data is transferred out of the SDO for a READ operation and into the SDI for a WRITE operation. The address is always the second through the eighth bit written after the enable (\bar{E}) pin goes low. If the first bit is a '1,' one or more WRITE cycles will occur. If the first bit is a '0,' one or more READ cycles will occur (see [Figure 7](#) and [Figure 8 on page 14](#)).

Data transfers can occur one byte at a time or in multiple byte burst mode, during which the address pointer will be automatically incremented. For a single byte transfer, one byte is read or written and then \bar{E} is driven high. For a multiple byte transfer all that is required is that \bar{E} continue to remain low. Under this condition, the address pointer will continue to increment as stated previously. Incrementing will continue until the device is deselected by taking \bar{E} high. The address will wrap to 00h after incrementing to 3Fh.

Reads and writes of the internal counters are performed through a set of buffer/transfer registers as shown in [Figure 9 on page 17](#). At the start of any read or write cycle, the counters are copied to the buffer/transfer registers. Thus, the time/date is effectively frozen for the user until the access is completed, although the counters are still running and maintaining the correct time.

Note: This is true both in READ and WRITE mode.

Figure 7. READ mode sequence

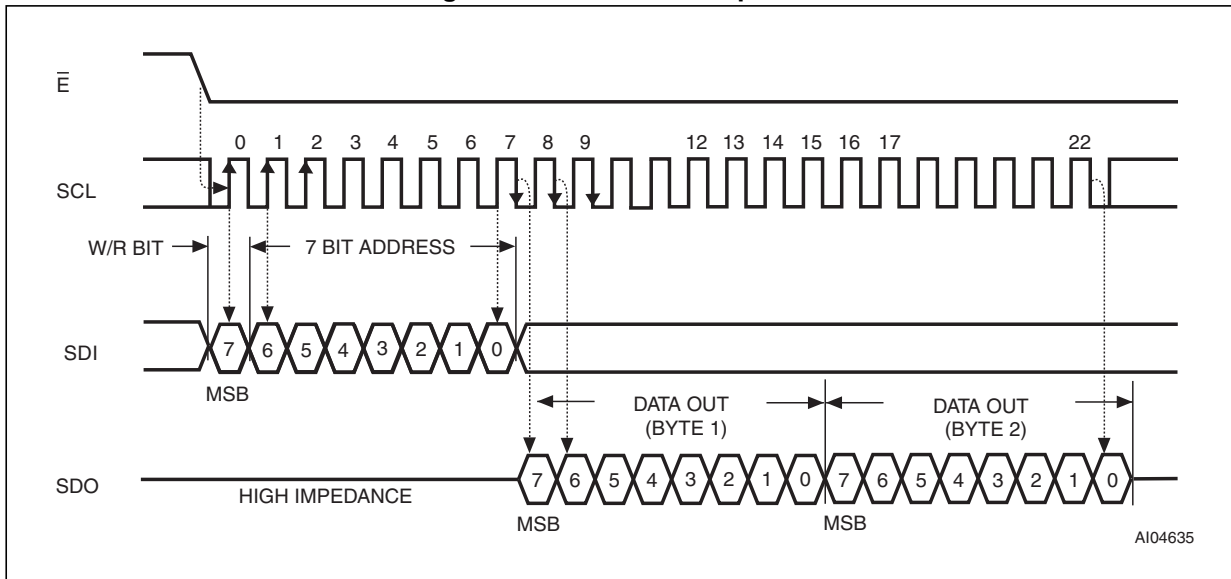
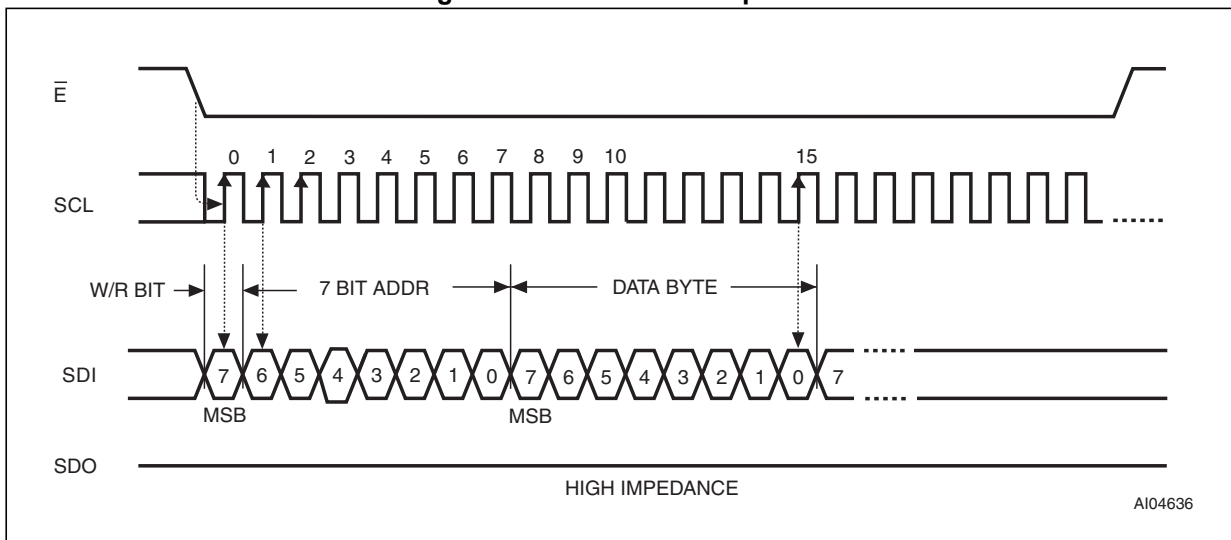

Figure 8. WRITE mode sequence



2.3 Data retention and battery switchover ($V_{SO} = V_{RST}$)

Once V_{CC} falls below the switchover voltage ($V_{SO} = V_{RST}$), the device automatically switches over to the battery and powers down into an ultra low current mode of operation to preserve battery life (see [Figure 22 on page 47](#)). At this time the clock registers and user RAM will be maintained by the attached battery supply.

When it is powered back up, the device switches back from battery to V_{CC} at $V_{SO} +$ hysteresis. When V_{CC} rises above V_{RST} , it will recognize the inputs. For more information on battery storage life refer to application note AN1012.

2.4 Power-on reset (t_{rec})

The M41T93 continuously monitors V_{CC} . When V_{CC} falls to the power fail detect trip point, the \overline{RST} output pulls low (open drain) and remains low after power-up for t_{rec} (210 ms typical) after V_{CC} rises above V_{RST} (max).

Note: The t_{rec} period does not affect the RTC operation. Write protect only occurs when V_{CC} is below V_{RST} . When V_{CC} rises above V_{RST} , the RTC will be selectable immediately. Only the \overline{RST} output is affected by the t_{rec} period.

The \overline{RST} pin is an open drain output and an appropriate pull-up resistor to V_{CC} should be chosen to control the rise time.

3 Clock operation

The M41T93 is driven by a quartz-controlled oscillator with a nominal frequency of 32.768 kHz. The accuracy of the real-time clock depends on the frequency of the quartz crystal that is used as the time-base for the RTC.

The 8-byte clock register (see [Table 3 on page 20](#)) is used to both set the clock and to read the date and time from the clock, in binary coded decimal format. Tenths/hundredths of seconds, seconds, minutes, and hours are contained within the first four registers.

Bit D7 of register 01h contains the STOP bit (ST). Setting this bit to a '1' will cause the oscillator to stop. When reset to a '0' the oscillator restarts within one second (typical).

Note: Upon initial power-up, the user should set the ST bit to a '1,' then immediately reset the ST bit to '0.' This provides an additional "kick-start" to the oscillator circuit.

Bits D6 and D7 of clock register 03h (century/ hours register) contain the CENTURY bit 0 (CB0) and CENTURY bit 1 (CB1). Bits D0 through D2 of register 04h contain the day (day of week). Registers 05h, 06h, and 07h contain the date (day of month), month, and years. The ninth clock register is the digital calibration register, while the analog calibration register is found at address 12h (these are both described in the clock calibration section). Bit D7 of register 09h (watchdog register) contains the oscillator fail interrupt enable bit (OFIE). When the user sets this bit to '1,' any condition which sets the oscillator fail bit (OF) (see [Oscillator fail detection on page 38](#)) will also generate an interrupt output.

Note: A WRITE to ANY location within the first eight bytes of the clock registers (00h-07h), including the ST bit and CB0-CB1 bits will result in an update of the RTC counters and a reset of the divider chain. This could result in an inadvertent change of the current time. For example, the ST bit is in the seconds register (address 01h) and the century bits (CB0-CB1) are in the hours register (address 03h), so the user should take care to not alter these other parameters when changing the ST bit or the century bits.

The eight clock registers may be read one byte at a time, or in a sequential block. At the start of a read cycle, a copy of the time/date counters is placed in the buffer/transfer registers and can then be transferred out sequentially without concern that the time/date increments during the transfer and thus yields a corrupt value. For example, if the user were to read the seconds register, then start another bus cycle to read the minutes register, the minutes counter could have incremented during the time between the two read cycles. The seconds and minutes values would not be from the same instant in time; they would not be coherent. By using the sequential read feature, the values shifted out are from the same instant in time and are thus coherent.

Similarly, when writing to the RTC registers, during one write cycle, the user can sequentially transfer all eight bytes of time/date into the buffer/transfer registers whereupon they will be loaded simultaneously into the RTC counters thus ensuring a coherent update of the time/date.

3.1 Clock data coherency

In order to synchronize the data during reads and writes of the real-time clock device, a set of buffer transfer registers resides between the SPI serial interface on the user side, and the clock/calendar counters in the part. While the read/write data is transferred in and out of the device one bit at a time to the user, the transfers between the buffer registers and counters occur such that all the bits are copied simultaneously. This keeps the data coherent and ensures that none of the counters are incremented while the data is being transferred.

Figure 9. Clock data coherency

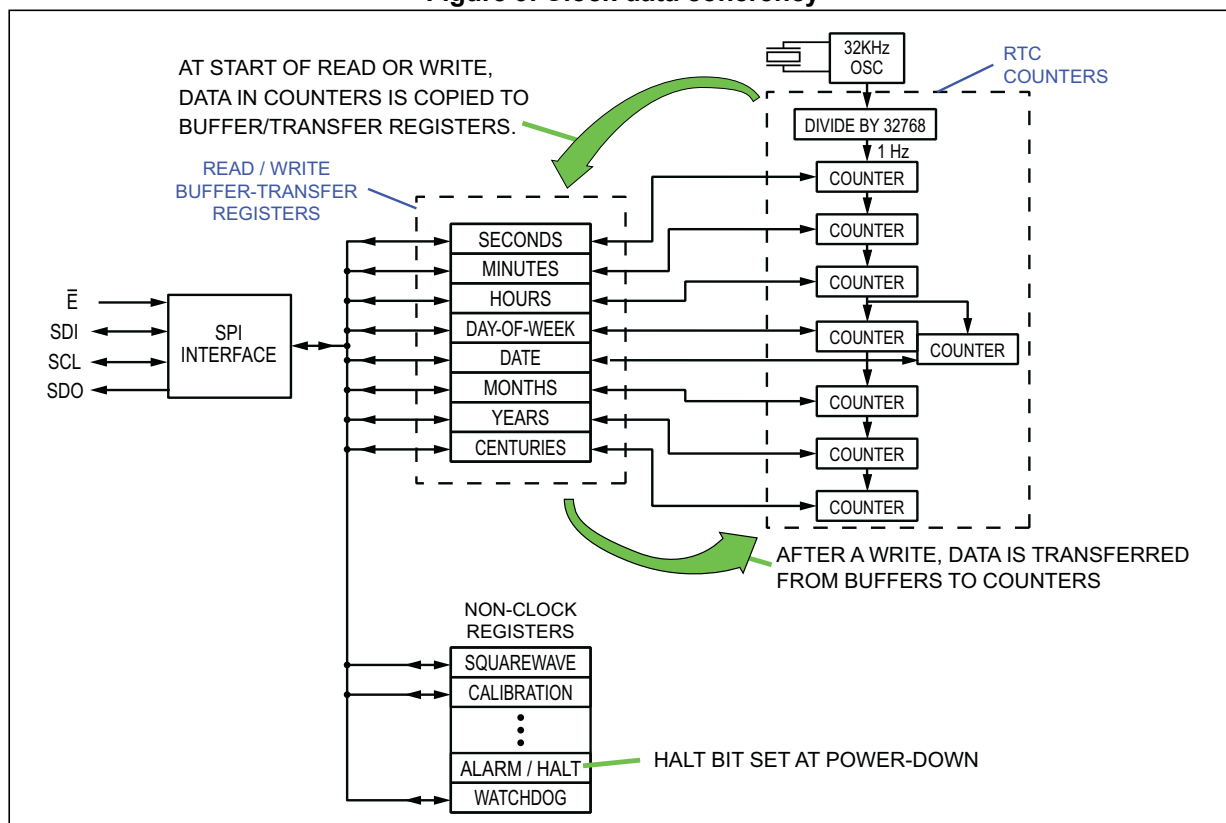

3.1.1 Example of incoherency

Without having the intervening buffer/transfer registers, if the user began directly reading the counters at 23:59:59, a read of the seconds register would return 59 seconds. After the address pointer incremented, the next read would return 59 minutes. Then the next read should return 23 hours, but if the clock happened to increment between the reads, the user would see 00 hours. When the time was re-assembled, it would appear as 00:59:59, and thus be incorrect by one hour.

By using the buffer/transfer registers to hold a copy of the time, the user is able to read the entire set of registers without any values changing during the read.

Similarly, when the application needs to change the time in the counters, it is necessary that all the counters be loaded simultaneously. Thus, the user writes sequentially to the various buffer/transfer registers, then they are copied to the counters in a single transfer thereby coherently loading the counters.

3.1.2 Accessing the device

The M41T93 is comprised of 32 addresses which provide access to registers for time and date, digital and analog calibration, two alarms, watchdog, flags, timer, squarewave and NVRAM. The clock and alarm parameters are in binary coded decimal (BCD) format. The calibration, timer, watchdog, and squarewave parameters are in a binary format.

In the case of the M41T93, at the start of each read or write serial transfer, the counters are automatically copied to the buffer registers. In the event of a write to any register in the range 0-7, at the end of the serial transfer, the buffer registers are copied back into the counters thus revising the date/time. Any of the eight clock registers (addresses 0-7) not updated during the transfer will have its old value written back into the counters. For example, if only the seconds value is revised, the other seven counters will end up with the same values they had at the start of the serial transfer.

However, writes which do not affect the clock registers - that is, a write only to the non-clock registers (addresses 0x08 to 0x1F) - will not cause the buffer registers to be copied back to the counters. The counters are only updated if a register in the range 0-7 was written.

Whenever the RTC registers (addresses 0-7) are written, the divider chain from the oscillator is reset.

3.2 Halt bit (HT) operation

When the part is powered down into battery backup mode, a control bit, called the Halt or HT bit, is set automatically. This inhibits any subsequent transfers from the counters to the buffer registers thereby freezing in the buffer registers the time/date of the last access of the part.

Repeated reads of the clock registers will return the same value. After the HT bit is cleared, by writing bit 6 of address 0x0C to 0, the next read of the RTC will return the present time.

Note: Writes to the RTC registers (addresses 0-7) with the HT bit set can cause time corruption. Since the buffer registers contain the time of the last access prior to the HT bit being set, any write in the address range 0-7 will result in the time of the last access being copied back into the counters.

Example: The last access was November 17, 2009, at 16:15:07.77. The system later powered down thus setting the HT bit and freezing that value in the buffers. Later, on December 18, 2009, at 03:22:43.35, the system is powered up and the user writes the seconds to 46 without first clearing the HT bit. At the end of the serial transfer, the old time/date, with the seconds modified to 46, will be written back into the clock registers thereby corrupting them. The new, wrong time will be November 17, 2009, at 16:15:46.77. This makes it appear the RTC lost time during the power outage.

Thus, at power-up, the user should always clear the HT bit (write bit 6 to 0 at address 0x0C) before writing to any address in the range 0-7.

A typical power-up flow is to read the time of last access, then clear the HT bit, then read the current time.

3.2.1 Power-down time stamp

Some applications may need to determine the amount of time spent in backup mode. That can be calculated if the time of power-down and the time of power-up are known. The latter is straightforward to obtain. But the time of power-down is only available if an access occurred just prior to power-down. That is, if there was an access of the device just prior to power-down, the time of the access would have been frozen in the buffer transfer registers and thus the approximate time of power-down could be obtained.

If an application requires the time of power-down, the best way to implement it is to set up the software to do frequent reads of the clock, such as once every 1 or 5 seconds. That way, at power-up, the buffer-transfer registers will contain a time value within 1 (or 5) seconds of the actual time of power-down. For more information, please refer to AN1572, "Power-down time-stamp function in serial real-time clocks (RTCs)".

Table 3. Clock/control register map (32 bytes)

Addr									Function/range BCD format	
	D7	D6	D5	D4	D3	D2	D1	D0		
00h	0.1 seconds				0.01 seconds				Seconds	00-99
01h	ST	10 seconds			Seconds				Seconds	00-59
02h	0	10 minutes			Minutes				Minutes	00-59
03h	CB1	CB0	10 hours		Hours (24-hour format)			Century/hours	0-3/00-23	
04h	0	0	0	0	0	Day of week		Day	01-7	
05h	0	0	10 date		Date: day of month			Date	01-31	
06h	0	0	0	10M	Month			Month	01-12	
07h	10 Years				Year				Year	00-99
08h	OUT	FT	DCS	DC4	DC3	DC2	DC1	DC0	Digital calibration	
09h	OFIE	BMB4	BMB3	BMB2	BMB1	BMB0	RB1	RB0	Watchdog	
0Ah	A1IE	SQWE	ABE	AI1 10M	Alarm1 month			AI1 month	01-12	
0Bh	RPT14	RPT15	AI1 10 date		Alarm1 date			AI1 date	01-31	
0Ch	RPT13	HT	AI1 10 hour		Alarm1 hour			AI1 hour	00-23	
0Dh	RPT12	Alarm1 10 minutes			Alarm1 minutes			AI1 min	00-59	
0Eh	RPT11	Alarm1 10 seconds			Alarm1 seconds			AI1 sec	00-59	
0Fh	WDF	AF1	AF2 ⁽¹⁾	BL	TF	OF	0	0	Flags	
10h	Timer countdown value								Timer value	
11h	TE	TI/TP	TIE	0	0	0	TD1	TD0	Timer control	
12h	ACS	AC6	AC5	AC4	AC3	AC2	AC1	AC0	Analog calibration	
13h	RS3	RS2	RS1	RS0	0	0	AL2E	OTP	SQW	
14h	0	0	0	AI2 10M	Alarm2 month			SRAM/AI2 month	01-12	
15h	RPT24	RPT25	AI2 10 date		Alarm2 month			SRAM/AI2 date	01-31	
16h	RPT23	0	AI2 10 hour		Alarm2 date			SRAM/AI2 hour	00-23	
17h	RPT22	Alarm2 10 minutes			Alarm2 minutes			SRAM/AI2 min	00-59	
18h	RPT21	Alarm2 10 seconds			Alarm2 seconds			SRAM/AI2 sec	00-59	
19h-1Fh	User SRAM (7 bytes)								SRAM	

1. AF2 will always read 0 if the AL2E bit is set to 0.

0 = Must be set to zero

ABE = Alarm in battery backup enable bit

A1IE = Alarm1 interrupt enable bit

AC0-AC6 = analog calibration bits

ACS = analog calibration sign bit

AF1, AF2 = Alarm flag

AL2E = Alarm 2 enable bit

BL = Battery low bit

BMB0-BMB4 = Watchdog multiplier bits

CB0, CB1 = Century bits

DC0-DC4 = Digital calibration bits

DCS = Digital calibration sign bit

FT = Frequency test bit

HT = Halt update bit

OF = Oscillator fail bit

OUT= Output level

OFIE = Oscillator fail interrupt enable

OTP = OTP control bit

RB0-RB2 = Watchdog resolution bits

RPT11-RPT15 = Alarm 1 repeat mode bits

RPT21-RPT25 = Alarm 2 repeat mode bits

RS0-RS3 = SQW frequency

SQWE = Square wave enable

SRAM/ALM2 = SRAM/Alarm 2 bit

ST = Stop bit

TD0, TD1 = Timer frequency bits

TE = Timer enable bit

TF = Timer flag

TI/TP = Timer interrupt or pulse

TIE = Timer interrupt enable

WDF = Watchdog flag

3.3 Real-time clock accuracy

The M41T93 is driven by a quartz controlled oscillator with a nominal frequency of 32,768 Hz. The accuracy of the real-time clock is dependent upon the accuracy of the crystal, and the match between the capacitive load of the oscillator circuit and the capacitive load for which the crystal was trimmed. Temperature also affects the crystal frequency, causing additional error (see [Figure 11 on page 26](#)).

The M41T93 provides the option of clock correction through either manufacturing calibration or in-application calibration. The total possible compensation is typically -93 ppm to $+156$ ppm. The two compensation circuits that are available are:

1. The analog calibration register (12h) can be used to adjust internal (on-chip) load capacitors for oscillator capacitance trimming. There are two load capacitors C_{XI} and C_{XO} (see [Figure 10](#)), nominally 25 pF each, one on either side of the crystal. The effective load capacitance is the series equivalent of C_{XI} and C_{XO} . For the nominal 25 pF, the effective load capacitance is 12.5pF. Writing to the analog calibration register adjusts both capacitors by the same amount. That is, the two capacitors will always have the same value. They can be adjusted up or down in 0.25 pF steps. The maximum adjustment up is +9.75 pF for a total of 34.75 pF (17.4 pF effective load) to slow the oscillator. The maximum downward adjustment is -18 pF for a total of 7 pF (3.5 pF effective load) to speed up the oscillator.
2. A digital calibration register (08h) can also be used to adjust the clock counter by adding or subtracting a pulse at the 512 Hz divider stage. This approach provides periodic compensation of approximately -63 ppm to $+126$ ppm (see [Digital calibration \(periodic counter correction\) on page 22](#)).

This range of load values translates to an approximate frequency range adjustment of -15 to $+95$ ppm (see [Analog calibration \(programmable load capacitance\) on page 25](#)).

Figure 10. Internal load capacitance adjustment

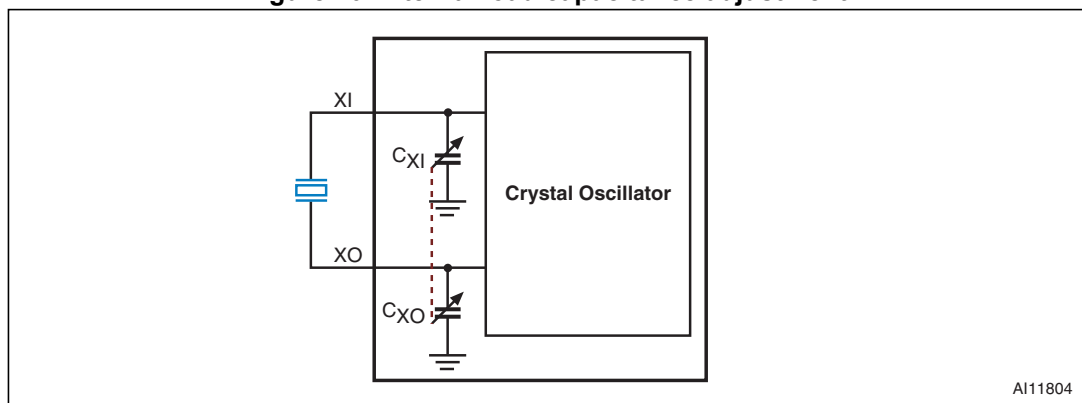

3.4 Clock calibration

The M41T93 oscillator is designed for use with a 12.5 pF crystal load capacitance. When the calibration circuit is properly employed, accuracy improves to better than ± 1 ppm at 25 °C.

The M41T93 design provides the following two methods for clock error correction.

3.4.1 Digital calibration (periodic counter correction)

This method employs the use of periodic counter correction by adjusting the ratio of the 100 Hz divider stage to the 512 Hz divider stage. Under normal operation, the 100Hz divider stage outputs precisely 100 pulses for every 512 pulses of the 512 Hz input stage to provide the input frequency to the fraction of seconds clock register. By adjusting the number of 512 Hz input pulses used to generate 100 output pulses, the clock can be sped up or slowed down, as shown in [Figure 13 on page 29](#).

When a non-zero value is loaded into the five calibration bits (DC4 – DC0) found in the digital calibration register (08h) and the sign bit is 1, (indicating positive calibration), the 100 Hz stage outputs 100 pulses for every 511 input pulses instead of the normal 512. Since the 100 pulses are now being output in a shorter window, this has the effect of speeding up the clock by 1/512 seconds for each second the circuit is active. Similarly, when the sign bit is 0, indicating negative calibration, the block outputs 100 pulses for every 513 input pulses. Since the 100 pulses are then being output in a longer window, this has the effect of slowing down the clock by 1/512 seconds for each second the circuit is active.

The amount of calibration is controlled by using the value in the calibration register (N) to generate the adjustment in one second increments. This is done for the first N seconds once every *eight* minutes for positive calibration, and for N seconds once every *sixteen* minutes for negative calibration (see [Table 4 on page 24](#)).

For example, if the calibration register is set to '100010,' then the adjustment will occur for two seconds in every minute. Similarly, if the calibration register is set to '000011,' then the adjustment will occur for 3 seconds in every alternating minute.

The digital calibration bits (DC4 – DC0) occupy the five lower order bits in the digital calibration register (08h). These bits can be set to represent any value between 0 and 31 in binary form. The sixth bit (DCS) is a sign bit; '1' indicates positive calibration, '0' indicates negative calibration. Calibration occurs within an 8-minute (positive) or 16-minute (negative) cycle. Therefore, each calibration step has an effect on clock accuracy of +4.068 or -2.034 ppm. Assuming that the oscillator is running at exactly 32,768 Hz, each of the 31 increments in the calibration byte would represent +10.7 or -5.35 seconds per month, which corresponds to a total range of +5.5 or -2.75 minutes per month.

One method of determining the amount of digital calibration required is to use the frequency test output (FT) of the device (see [Section 3.14: IRQ/FT/OUT pin, frequency test, interrupts and the OUT bit on page 38](#) for more information on enabling the FT output).

When FT is enabled, a 512 Hz signal is output on the $\overline{\text{IRQ}}/\text{FT}/\text{OUT}$ pin. This signal can be measured using a highly accurate timing device such as a frequency counter. The measured value is then compared to 512 Hz and the oscillator error in ppm is then determined.

The user should keep in mind that changes in the digital calibration value will not affect the signal measured on the FT pin. While the analog calibration circuit does affect the oscillator,

the digital calibration circuitry uses periodic counter correction which occurs downstream of the 512 Hz divider chain and hence has no effect on the FT pin.

- Note:
- 1 *The modified pulses are not observable on the frequency test (FT) output, nor will the effect of the calibration be measurable real-time, due to the periodic nature of the error compensation.*
 - 2 *Positive digital calibration is performed on an eight minute cycle, therefore the value in the calibration register should not be modified more frequently than once every eight minutes for positive values of calibration. Negative digital calibration is performed on a sixteen minute cycle, therefore negative values in the calibration register should not be modified more frequently than once every sixteen minutes.*

Table 4. Digital calibration values

Calibration value (binary) DC4 – DC0	Calibration value rounded to the nearest ppm	
	Negative calibration (DCS = 0) to slow a fast clock	Positive calibration (DCS = 1) to speed up a slow clock
0 (00000)	0	0
1 (00001)	-2	4
2 (00010)	-4	8
3 (00011)	-6	12
4 (00100)	-8	16
5 (00101)	-10	20
6 (00110)	-12	24
7 (00111)	-14	28
8 (01000)	-16	33
9 (01001)	-18	37
10 (01010)	-20	41
11 (01011)	-22	45
12 (01100)	-24	49
13 (01101)	-26	53
14 (01110)	-28	57
15 (01111)	-31	61
16 (10000)	-33	65
17 (10001)	-35	69
18 (10010)	-37	73
19 (10011)	-39	77
20 (10100)	-41	81
21 (10101)	-43	85
22 (10110)	-45	90
23 (10111)	-47	94
24 (11000)	-49	98
25 (11001)	-51	102
26 (11010)	-53	106
27 (11011)	-55	110
28 (11100)	-57	114
29 (11101)	-59	118
30 (11110)	-61	122
31 (11111)	-63	126
N	N/491520 (per minute)	N/245760 (per minute)

3.4.2 Analog calibration (programmable load capacitance)

A second method of calibration employs the use of programmable internal load capacitors to adjust (or trim) the oscillator frequency. As discussed in [Section 3.4.1](#), the 512 Hz frequency test output can be used to determine the amount of frequency error in the oscillator. Changes in the analog calibration value will affect the frequency test output, thus the user can immediately see the effects of these changes (see [Section 3.14 on page 38](#) for more information on enabling the FT output).

By design, the oscillator is intended to be 0 ppm (\pm crystal accuracy) at room temperature (25 °C, see [Figure 11 on page 26](#)) when a 12.5 pF crystal is connected. Referring to [Figure 12 on page 28](#), the device has two load capacitors, C_{XI} and C_{XO} , connected from the XI and XO pins to ground. These are nominally 25 pF each. The effective load capacitance is the series equivalent of these two:

$$C_{LOAD} = \frac{C_{XI} \cdot C_{XO}}{C_{XI} + C_{XO}}$$

For the nominal case of $C_{XI} = C_{XO} = 25$ pF,

$$C_{LOAD} = \frac{25 \cdot 25}{25 + 25} = 12.5 \text{ pF}$$

Thus, the nominal effective load capacitance matches the crystal specification of 12.5 pF.

The analog calibration register can be digitally adjusted, up or down, in increments of 0.25 pF, to change the capacitance of C_{XI} and C_{XO} . The default value is 25 pF. The maximum is 34.75 pF, to slow the clock, and the minimum is 7 pF, to speed up the clock.

The analog calibration value is in sign-magnitude format with the most significant bit the sign bit. The table below shows the approximate weighting for each of the bits.

b7	b6	b5	b4	b3	b2	b1	b0	
sign	16	8	4	2	1	0.5	0.25	pF

While the 7 bits plus sign suggest a total adjustment range of ± 31.75 pF, the logic inside the device limits this to the range +9.75 pF / -18 pF. The table below summarizes the nominal, upper and lower limits of the load capacitance and the expected effect on the operating frequency of the oscillator.

C_{LOAD} (pF)	C_{XI}, C_{XO} (pF)	ACAL (Addr 0x12)	Oscillator frequency
12.5	25 (default)	0x00	0 ppm
17.4	34.75 (+9.75)	0x27	-15 ppm (slow)
3.5	7 (-18)	0xC8	+95 ppm (fast)

The asymmetrical nature of the adjustment range (+9.75 pF / -18 pF) is due to the nature of the frequency versus temperature curve ([Figure 11](#)) of 32.768 kHz watch crystals. The oscillator will slow down at temperatures both above and below room level (~ 25 °C). Hence, it usually needs to be sped up, so more adjustment range is provided to remove capacitance than to increase it.

As shown in *Figure 12*, the relationship between oscillator speed and load capacitance is not linear. When operating on the left end of the curve, small changes in load capacitance have more effect than when operating on the right end of the curve. For example, at -15 pF, a 3 pF reduction to -18 pF should result in the part running about 30 ppm faster (from +65 ppm to +95 ppm). Conversely, at +5 pF, adding 3 pF to get to +8 pF should only slow the part by about 4 ppm (from -8 ppm to -12 ppm).

3.4.3 Pre-programmed calibration value

Users of the M41T83 in the embedded crystal package have the option of using the factory programmed analog calibration value (refer to *Section 3.16 on page 42*).

Figure 11. Crystal accuracy across temperature

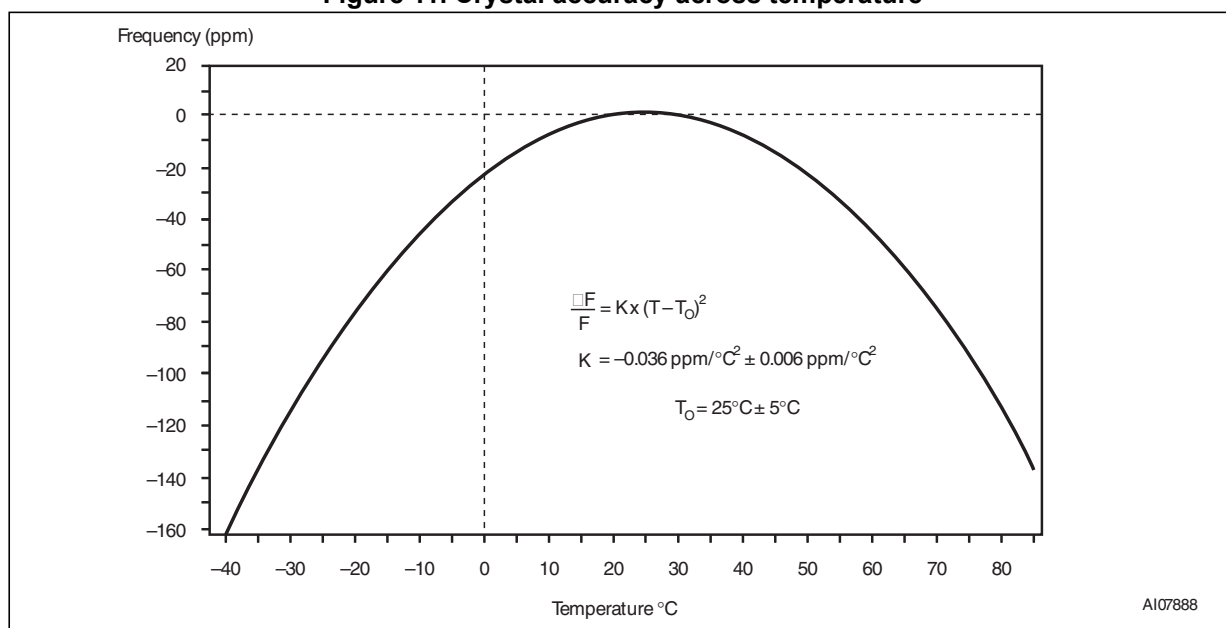

Table 5. Analog calibration values

Addr	Analog calibration value	D7	D6	D5	D4	D3	D2	D1	D0	C _{XI} , C _{XO}	C _{LOAD} ⁽¹⁾
		ACS (±)	AC6 (16 pF)	AC5 (8 pF)	AC4 (4 pF)	AC3 (2 pF)	AC2 (1 pF)	AC1 (0.5 pF)	AC0 (0.25 pF)		
12h	0 pF	x	0	0	0	0	0	0	0	25 pF	12.5 pF
	3 pF	0	0	0	0	1	1	0	0	28 pF	14 pF
	5 pF	0	0	0	1	0	1	0	0	30 pF	15 pF
	-7 pF	1	0	0	1	1	1	0	0	18 pF	9 pF
	9.75 pF ⁽²⁾	0	0	1	0	0	1	1	1	34.75 pF	17.4 pF
	-18 pF ⁽³⁾	1	1	0	0	1	0	0	0	7 pF	3.5 pF

1. C_{LOAD} = 1/(1/C_{XI} + 1/C_{XO})
2. Maximum negative calibration value
3. Maximum positive calibration value

The on-chip capacitance can be calculated as follows:

$$C_{\text{LOAD}} = 12.5 + [\text{ACS}:(\text{AC6}:\text{AC0 value, decimal})] \bullet 0.125 \text{ pF}$$

where ACS is the sign.

Examples:

ACAL (addr 12h) = 0 → $C_{\text{LOAD}} = 12.5 \text{ pF}$

ACAL = 10111100b → $C_{\text{LOAD}} = 5 \text{ pF}$

ACAL = 00010100b → $C_{\text{LOAD}} = 15 \text{ pF}$

With the analog calibration adjusted to its lowest value, the oscillator will see a minimum of 3.5 pF load capacitance as shown on the bottom row of [Table 5](#).

Note: *These are typical values, and the total load capacitance seen by the crystal will include approximately 1-2 pF of package and board capacitance in addition to the analog calibration register value.*

Any invalid value of analog calibration will result in the default capacitance of 25 pF (for C_{X1} and C_{X0}).

Combining the digital adjustment range (−63 to +126 ppm) and analog adjustment range (−15 to +95 ppm), the approximate overall adjustment range of the M41T93's timekeeping is −78 to +221 ppm.

[Figure 12](#) represents a typical curve of clock ppm adjustment versus the analog calibration value. Actual crystals may vary, so users should evaluate the crystals to be used with an M41T93 device before establishing the adjustment values for a given application.

Figure 12. Clock accuracy vs. on-chip load capacitors

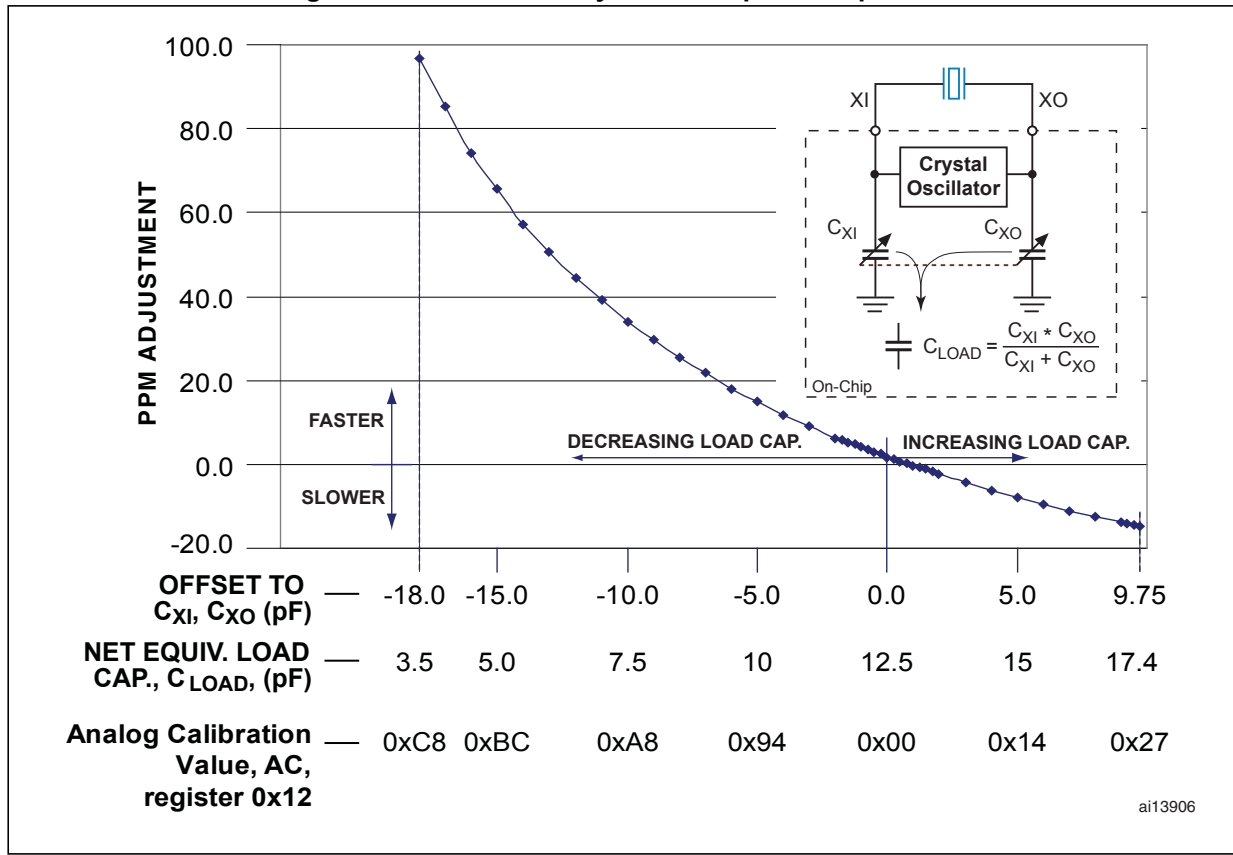

Two methods are available for ascertaining how much calibration a given M41T93 may require:

- The first involves setting the clock, letting it run for a month and comparing it to a known accurate reference and recording deviation over a fixed period of time. This allows the designer to give the end user the ability to calibrate the clock as the environment requires, even if the final product is packaged in a non-user serviceable enclosure. The designer could provide a simple utility that accesses either or both of the calibration bytes.
- The second approach is better suited to a manufacturing environment, and involves the use of the $\overline{\text{IRQ}}/\text{FT}/\text{OUT}$ pin. The $\overline{\text{IRQ}}/\text{FT}/\text{OUT}$ pin will toggle at 512 Hz when FT and OUT bits = '1' and ST = '0.' Any deviation from 512 Hz indicates the degree and direction of oscillator frequency shift at the test temperature. For example, a reading of 512.010124 Hz would indicate a +20 ppm oscillator frequency error, requiring either a -10 (xx001010) to be loaded into the digital calibration byte, or +6 pF (00011000) into the analog calibration byte for correction.

Any deviation from 512 Hz indicates the degree and direction of oscillator frequency shift at the test temperature. For example, a reading of 512.010124 Hz would indicate a +20 ppm oscillator frequency error, requiring either a -10 (xx001010) to be loaded into the digital calibration byte, or +6 pF (00011000) loaded into the analog calibration byte, for correction.

Note: Setting or changing the digital calibration byte does not affect the frequency test, square wave, or watchdog timer frequency, but changing the analog calibration byte DOES affect all functions derived from the low current oscillator (see Figure 13).

Figure 13. Clock divider chain and calibration circuits

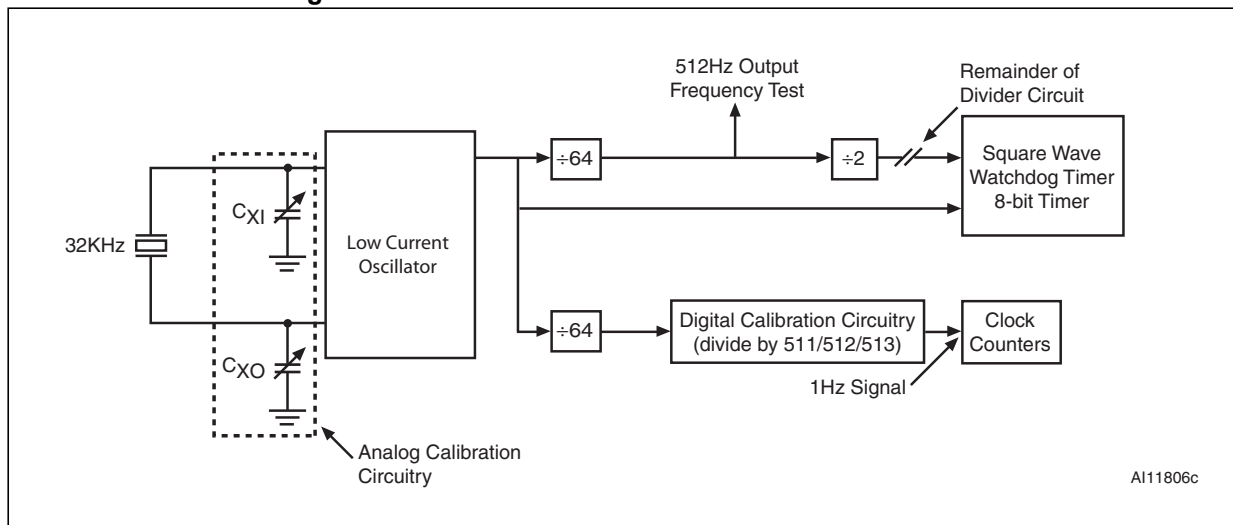
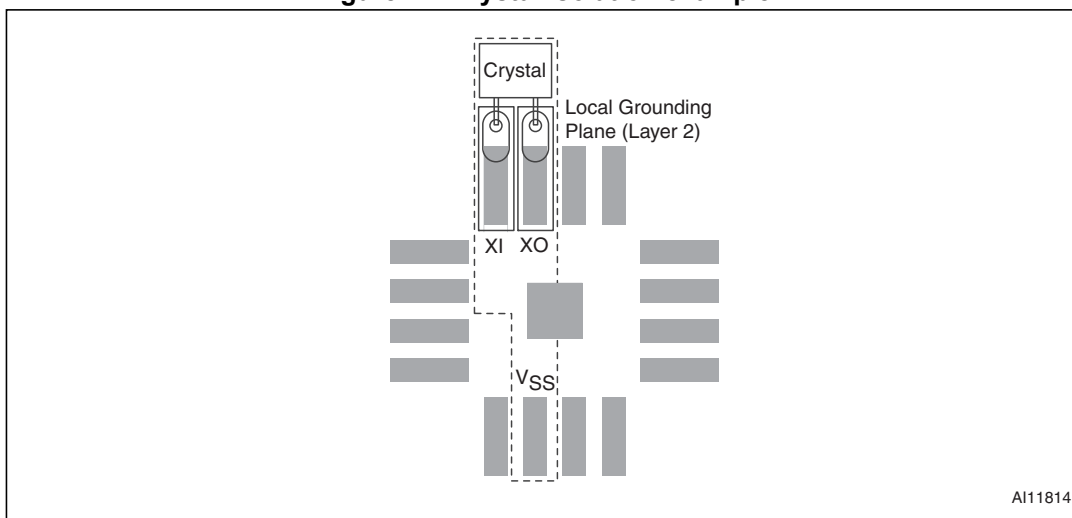

Figure 14. Crystal isolation example



Note: The substrate pad should be tied to V_{SS}.

3.5 Setting the alarm clock registers

Address locations 0Ah-0Eh (alarm 1) and 14h-18h (alarm 2) contain the alarm settings. Either alarm can be configured independently to go off at a prescribed time on a specific month, date, hour, minute, or second, or repeat every year, month, day, hour, minute, or second. Bits RPT15–RPT11 and RPT25–RPT21 put the alarms in the repeat mode of operation. [Table 6 on page 31](#) shows the possible bit configurations.

Codes not listed in the table default to the once-per-second mode to quickly alert the user of an incorrect alarm setting. When the clock information matches the alarm clock settings based on the match criteria defined by RPT15–RPT11 and/or RPT25–RPT21, AF1 (alarm 1 flag) or AF2 (alarm 2 flag) is set. If A1IE (alarm 1 interrupt enable) is set, the alarm condition activates the $\overline{\text{IRQ}}/\text{FT}/\text{OUT}$ output pin. To disable either of the alarms, write a '0' to the alarm date registers and to the RPTx5–RPTx1 bits.

Note: *If the address pointer is allowed to increment to the flag register address, or the last address written is "Alarm Seconds," the address pointer will increment to the flag address, and an alarm condition will not cause the interrupt/flag to occur until the address pointer is moved to a different address.*

The $\overline{\text{IRQ}}$ output is cleared by a READ of the flags register (0Fh). A subsequent READ of the flags register is necessary to see that the value of the alarm flag has been reset to 0.

The $\overline{\text{IRQ}}/\text{FT}/\text{OUT}$ pin can also be activated in the battery backup mode. This requires the ABE bit (alarm in backup enable) to be set (see [Section 3.14.2: Backup mode](#) for additional conditions which apply). Once an interrupt is asserted in backup mode, it will remain true until V_{CC} is restored and a subsequent read of the flags register occurs.

3.6 Optional second programmable alarm

When the alarm 2 enable (AL2E) bit (D1 of address 13h) is set to a logic 1, registers 14h through 18h provide control for a second programmable alarm which operates in the same manner as the alarm function described above. When the alarm 2 condition is met, the AF2 bit will be set. Reading the flags register (0Fh) will clear it. There is no $\overline{IRQ2}$ interrupt output on the M41T93, so no external event can be directly triggered by the alarm 2 function, but the AF2 bit can be polled to initiate a response.

The AL2E bit defaults on initial power-up to a logic 0 (alarm 2 disabled). In this mode, the five address bytes (14h-18h) function as additional user SRAM, for a total of 12 bytes of non-volatile SRAM.

Figure 15. Backup mode alarm waveform

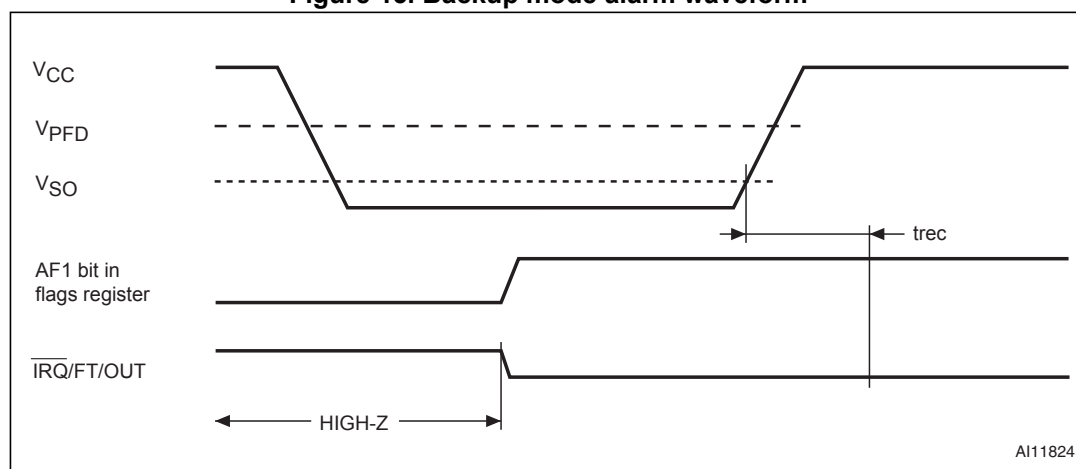

Note: ABE and A1IE bits = 1.

Table 6. Alarm repeat modes

RPT5	RPT4	RPT3	RPT2	RPT1	Alarm setting
1	1	1	1	1	Once per second
1	1	1	1	0	Once per minute
1	1	1	0	0	Once per hour
1	1	0	0	0	Once per day
1	0	0	0	0	Once per month
0	0	0	0	0	Once per year

3.7 Watchdog timer

The watchdog timer can be used to detect an out-of-control microprocessor. The user programs the watchdog timer by setting the desired amount of time-out into the watchdog register, address 09h. Bits BMB4-BMB0 store a binary multiplier and the two lower order bits RB1-RB0 select the resolution, where 00 = 1/16 second, 01 = 1/4 second, 10 = 1 second, and 11 = 4 seconds. The amount of time-out is then determined to be the multiplication of the five-bit multiplier value with the resolution. (For example: writing 00001110 in the watchdog register = 3*1, or 3 seconds). If the processor does not reset the timer within the

specified period, the M41T93 sets the WDF (watchdog flag) and generates a watchdog interrupt.

Watchdog, address 09h	D7	D6	D5	D4	D3	D2	D1	D0
	OFIE	BMB4	BMB3	BMB2	BMB1	BMB0	RB1	RB0

The watchdog timer is reset by writing to the watchdog register. The time-out period then starts over.

Watchdog interrupt

On the M41T93, provided that the necessary configuration bits are set, the $\overline{\text{IRQ/FT/OUT}}$ output will be asserted when the watchdog times out (see [Section 3.14](#) for additional conditions which apply).

Should the watchdog time out, to de-assert the $\overline{\text{IRQ/FT/OUT}}$ output, the lower seven bits of the watchdog register (09h) must be written. This will de-assert the output and re-initialize the watchdog. Writing these seven bits to 0 will de-assert the output and disable the watchdog.

A READ of the flags register will reset the watchdog flag (bit D7; register 0Fh) but not de-assert the $\overline{\text{IRQ/FT/OUT}}$ output. The watchdog function is automatically disabled upon power-up and the watchdog register is cleared.

3.8 8-bit (countdown) timer

The timer value register is an 8-bit binary countdown timer. It is enabled and disabled via the timer control register (11h) TE bit. Other timer properties such as the source clock, or interrupt generation are also selected in the timer control register (see [Table 7](#)). For accurate read back of the countdown value, the serial clock (SCL) must be operating at a frequency of at least twice the selected timer clock.

The timer control register selects one of four source clock frequencies for the timer (4096, 64, 1, or 1/60 Hz), and enables/disables the timer. The timer counts down from a software-loaded 8-bit binary value (register 10h) and decrements to 1. On the next tick of the counter, it reloads the timer countdown value and sets the timer flag (TF) bit. The TF bit can only be cleared by software. When asserted, the timer flag (TF) can also be used to generate an interrupt ($\overline{\text{IRQ/FT/OUT}}$) on the M41T93. Writing the timer countdown value (10h) has no effect on the TF bit or the $\overline{\text{IRQ/FT/OUT}}$ output.

3.8.1 Timer interrupt/output

On the M41T93, there are two choices for the output depending on the $\overline{\text{TI/TP}}$ configuration bit (timer interrupt/timer pulse, bit 6, register 11h).

Normal interrupt mode

With $\overline{\text{TI/TP}} = 0$, the output will assert like a normal interrupt, staying low until the TF bit is cleared by software by reading the flags register (0Fh).

Free-running mode

When $\overline{\text{TI/TP}}$ is a 1, the output is a free-running waveform as depicted in [Figure 16](#). After being low for the specified time (as shown in [Table 8](#)), the output automatically goes high

without need of software clearing any bits. The TF bit will still be set each time the timer reloads, but it is not necessary for the software to clear it in this mode. Furthermore, clearing the TF bit has no effect on the output in this mode.

While writes to the timer countdown register (10h) control the reload value, reads of this register return the current countdown timer value.

Table 7. Timer control register map

Addr	D7	D6	D5	D4	D3	D2	D1	D0	Function
0Fh	WDF	AF1	AF2	BL	TF	OF	0 ⁽¹⁾	0 ⁽¹⁾	Flags
10h	Timer countdown value ⁽²⁾								Timer value
11h	TE	$\overline{\text{TI/TP}}$	TIE	0 ⁽¹⁾	0 ⁽¹⁾	0 ⁽¹⁾	TD1	TD0	Timer control

1. Bit positions labeled with 0 should always be written with logic 0.
2. Writing to the timer register will not reset the TF bit nor clear the interrupt.

When the timer is in the free-running mode, with a value of n programmed into the timer countdown value, the output will nominally be low for one cycle of the specified clock source and high for n-1 cycles with an overall period of n cycles. Thus, the countdown period is n/source clock frequency.

For the special case of n = 1, as shown in [Table 8](#), when the clock source is 4096 or 64 Hz, the low time (T_L) is half the clock period instead of a full clock period.

Table 8. Timer interrupt operation in free-running mode (with $\overline{\text{TI/TP}} = 1$)

Source clock (Hz)	$\overline{\text{IRQ}}$ low time – T _L (seconds) ⁽¹⁾		$\overline{\text{IRQ}}$ period – T _{$\overline{\text{IRQ}}$} (seconds)	
	n = 1 ⁽²⁾	n > 1	n = 1	n > 1
4096	1/8192 = 122 μs	1/4096 = 244 μs	1/4096 = 244 μs	n / 4096
64	1/128 = 7.8 ms	1/64 = 15.6 ms	1/64 = 15.6 ms	n / 64
1	1/64	1/64	1	n
1/60	1/64	1/64	1 minute	n minutes

1. $\overline{\text{IRQ/FT/OUT}}$ is asserted coincident with TF going true.
2. n = loaded countdown timer value (0 < n < 255). The timer is stopped when n = 0.

Figure 16. Timer output waveform in free-running mode (with $\overline{\text{TI/TP}} = 1$)

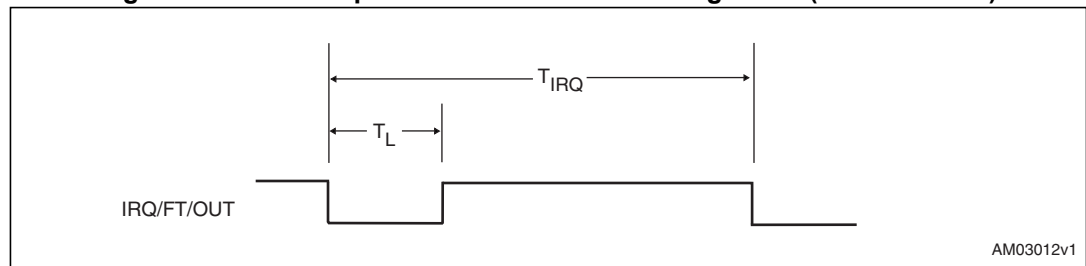

3.8.2 Timer flag (TF)

At the end of a timer countdown, when the timer reloads, TF is set to logic 1. Regardless of the state of TF bit (or \overline{TI}/TP bit), the timer will continue decrementing and reloading.

If both timer and alarm interrupts are used in the application, the source of the interrupt can be determined by reading the flag bits. Refer to [Section 3.14](#) for more information on the interaction of these bits. The TF bit is cleared by reading the flags register. This will de-assert an interrupt output due to the timer.

3.8.3 Timer interrupt enable (TIE)

In normal interrupt mode ($\overline{TI}/TP = 0$), when TF is asserted, the interrupt output is asserted (if TIE = 1). To de-assert the interrupt, the TF bit or the TIE bit must be reset. Disabling the interrupt by clearing the TIE bit will de-assert the output, but does not clear the TF bit. Thus, if TIE is re-enabled prior to clearing TF, the interrupt will assert immediately.

3.8.4 Timer enable (TE)

- TE = 0
When TE = 0, or when the timer register (10h) is set to 0, the timer is disabled.
- TE = 1
The timer is enabled. TE is reset (disabled) on power-down. When re-enabled, the counter will begin counting from the same value as when it was disabled.

3.8.5 TD1/0

These are the timer source clock frequency selection bits (see [Table 9](#)). These bits determine the source clock for the countdown timer (see [Table 7](#)). When not in use, the TD1 and TD0 bits should be set to 11 (1/60 Hz) for power saving.

Table 9. Timer source clock frequency selection (244.1 μ s to 4.25 hrs)

TD1	TD0	Timer source clock frequency (Hz)
0	0	4096 (244.1 μ s)
0	1	64 (15.6 ms)
1	0	1 (1 s)
1	1	1/60 (60 s)

Note: Writing to the timer register will not reset the TF bit nor clear the interrupt.

3.9 Square wave output

The M41T93 offers the user a programmable square wave function which is output on the SQW pin. RS3-RS0 bits located in 13h establish the square wave output frequency. These frequencies are listed in [Table 10](#). Once the selection of the SQW frequency has been completed, the SQW pin can be turned on and off under software control with the square wave enable bit (SQWE) located in register 0Ah.

Note: If the SQWE bit is set to '1', and V_{CC} falls below the switchover (V_{SO}) voltage, the squarewave output will be disabled.

Table 10. Square wave output frequency

Square wave bits				Square wave	
RS3	RS2	RS1	RS0	Frequency	Units
0	0	0	0	None	–
0	0	0	1	32.768	kHz
0	0	1	0	8.192	kHz
0	0	1	1	4.096	kHz
0	1	0	0	2.048	kHz
0	1	0	1	1.024	kHz
0	1	1	0	512	Hz
0	1	1	1	256	Hz
1	0	0	0	128	Hz
1	0	0	1	64	Hz
1	0	1	0	32	Hz
1	0	1	1	16	Hz
1	1	0	0	8	Hz
1	1	0	1	4	Hz
1	1	1	0	2	Hz
1	1	1	1	1	Hz

3.10 Battery low warning

The M41T93 automatically checks the battery each time V_{CC} powers up and each time the clock rolls over at midnight.

V_{BAT} is compared to V_{BL} (approximately 2.5 V), then the battery low (BL) bit, D4 of flags register 0Fh, is set if the battery voltage is found to be less than V_{BL} . Similarly, if V_{BAT} is greater than V_{BL} , the BL bit is cleared during battery check.

The BL bit retains its state until the next battery check occurs. This means the BL bit will not clear immediately upon battery replacement, but only after the next battery check occurs at the next power-up or midnight rollover.

If a battery low is generated during a power-up sequence, this indicates that the battery is below approximately 2.5 volts and may not be able to maintain data integrity. Clock data should be considered suspect and verified as correct. A fresh battery should be installed.

If a battery low indication is generated during the 24-hour interval check, this indicates that the battery is near end of life. However, data is not compromised due to the fact that a nominal V_{CC} is supplied. In order to ensure data integrity during subsequent periods of battery backup mode, the battery should be replaced.

Midnight rollover check

As shown in *Figure 17*, during the midnight rollover check, the M41T93 applies a load to the battery, then compares V_{BAT} to V_{BL} and updates the BL bit accordingly. Because a load is present, an open condition on the V_{BAT} pin will result in the BL bit being set. After the check is performed, the RTC removes the load.

Power-up battery check

During the power-up check, no load is applied to the battery under the assumption the battery has already been stressed to its working level by having powered the RTC in backup mode. If no battery is present, V_{BAT} will be floating and the battery check result will be indeterminate.

Figure 17. Battery check

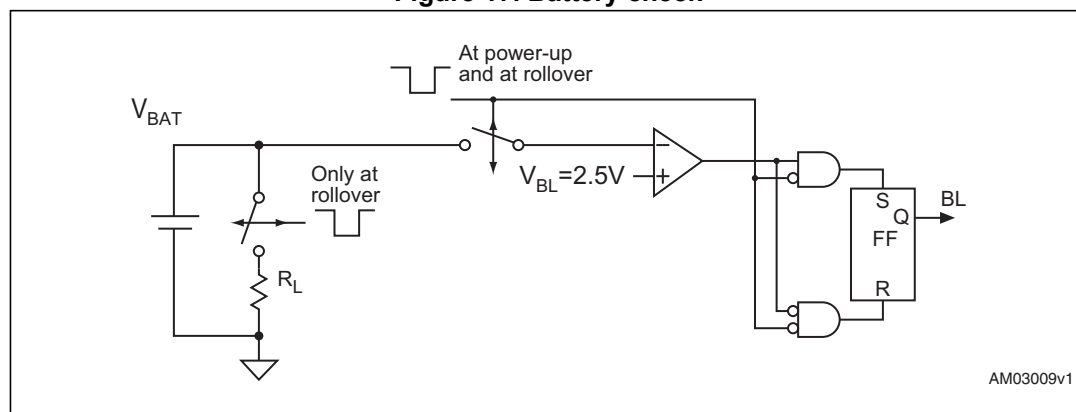

AM03009v1

The M41T93 only checks the battery when powered by VCC. It does not check the battery while in backup mode. Thus, users are advised that during long periods in backup mode, the battery can drop to a level at which timekeeping may fail or data becomes corrupted. If, at power-up, a battery low is indicated, data integrity should be verified.

Forcing a battery check

If it is desired to check the battery at an arbitrary time, one common technique is for the application software to write the time to just before midnight, 23:59:59, and then wait two seconds thereby letting the clock rollover and causing the BL bit to update. The application then restores the time back to its previous value plus two seconds.

3.11 Century bits

The M41T93 includes 2 century bits (CB1, CB0) which function as a 2-bit binary counter that increments at the end of each century. The user may arbitrarily assign the meaning of CB1:CB0 to represent any century value, but the simplest way of using these bits is to extend the year register by mapping them directly to bits 9 and 8 (with the year register comprising bits 7:0). Higher order century bits can be maintained in the application software.

Figure 18. Two-bit binary counter (century bits CB1:CB0)

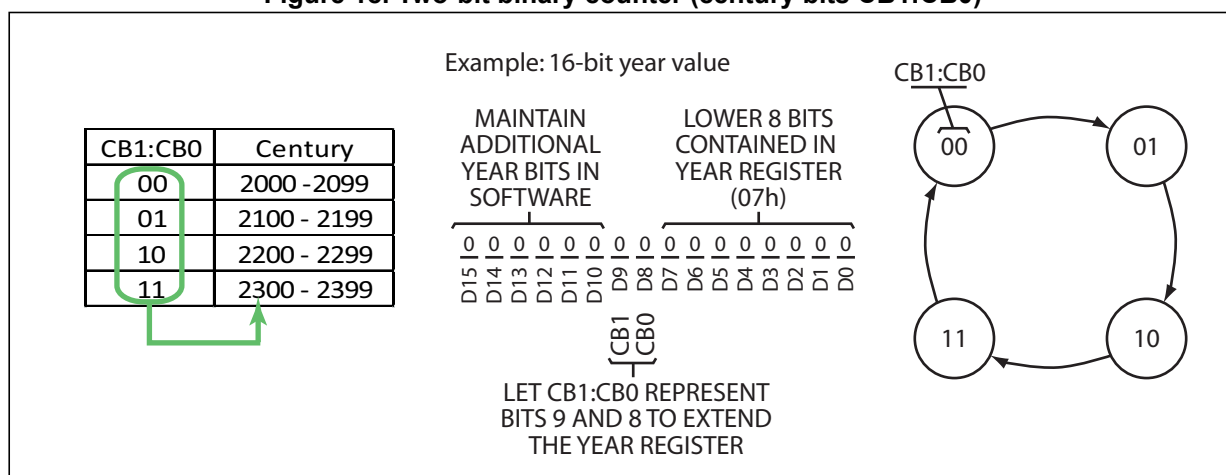

In this example, CB1:CB0 represent the two lower bits of the century byte.

Leap year

Leap year occurs every four years, in years which are multiples of 4. For example, 2012 was a leap year. An exception to that is any year which is a multiple of 100. For example, the year 2100 is not a leap year. A contradiction to that is that years which are multiples of 400 are indeed leap years. Hence, while 2100 is not a leap year, 2400 is.

During any year which is a multiple of 4, ST RTC and TIMEKEEPER devices will automatically insert leap day, February 29. Therefore, the application software must correct for this during the exception years (2100, 2200, etc.) as noted above.

3.12 Oscillator fail detection

If the oscillator fail (OF) bit is internally set to a 1, this indicates that the oscillator has either stopped, or was stopped for some period of time. This bit can be used to judge the validity of the clock and date data. This bit will be set to 1 any time the oscillator stops.

In the event the OF bit is found to be set to 1 at any time other than the initial power-up, the STOP bit (ST) should be written to a 1, then immediately reset to 0. This will restart the oscillator. This is called kick-starting, and it injects extra current into the oscillator for a short period of time to help it get started.

The following conditions can cause the OF bit to be set:

- The voltage present on V_{CC} or battery is insufficient to support oscillation.
- The ST bit is set to 1.
- External interference of the crystal
- The first time power is applied (defaults to a 1 on power-up).

Note: If the OF bit cannot be written to 0 four seconds after the initial power-up, the user should perform the kick-start of the oscillator as noted above. Kick-starting should only be performed when the OF bit is set.

For the M41T93, if the oscillator fail interrupt enable bit (OFIE) is set to a 1, the $\overline{IRQ}/FT/OUT$ pin will also be asserted (see [Section 3.13](#) and [Section 3.14](#) for additional conditions which apply). The $\overline{IRQ}/FT/OUT$ output is de-asserted by resetting the OF bit to 0, NOT by reading the flags register. The OF bit will remain a 1 until written to 0. Reading the flags register has no effect on OF.

The oscillator must start and have run for at least 4 seconds before attempting to reset the OF bit to 0.

The oscillator fail detect circuit functions during backup mode. If a triggering event occurs to disrupt the oscillator during a power-down condition, the OF bit will be set accordingly.

3.13 Oscillator fail interrupt enable

With the OFIE bit set, the OF bit will cause the $\overline{IRQ}/FT/OUT$ output to be asserted (see [Section 3.14.1](#) and [3.14.2](#) for additional conditions that apply). The $\overline{IRQ}/FT/OUT$ output is cleared by resetting the OF bit to 0 (NOT by reading the flags register). Clearing the OFIE bit will also cause the $\overline{IRQ}/FT/OUT$ output to de-assert, but if OFIE is subsequently set prior to clearing OF, the $\overline{IRQ}/FT/OUT$ output will assert immediately upon setting OFIE. Clearing the OF bit is necessary to prevent such an inadvertent interrupt.

If the alarm in backup enable bit, ABE, is set (along with OFIE), the oscillator fail detect will cause an interrupt in the $\overline{IRQ}/FT/OUT$ pin during backup mode. For additional information on this, refer to [Section 3.14.2](#).

3.14 $\overline{IRQ}/FT/OUT$ pin, frequency test, interrupts and the OUT bit

Four interrupt sources, the frequency test function, and the discrete output bit OUT all share the $\overline{IRQ}/FT/OUT$ pin. Priority is built into the part such that some functions dominate others. Additionally, the priority depends on configuration bits such as OUT and ABE, and on whether the part is operating on V_{CC} or is in the backup mode. This pin is an open drain output and requires an external pull-up resistor.

Figure 19 shows the various signal sources and controlling bits for the $\overline{\text{IRQ/FT/OUT}}$ output pin.

Figure 19. $\overline{\text{IRQ/FT/OUT}}$ output pin circuit

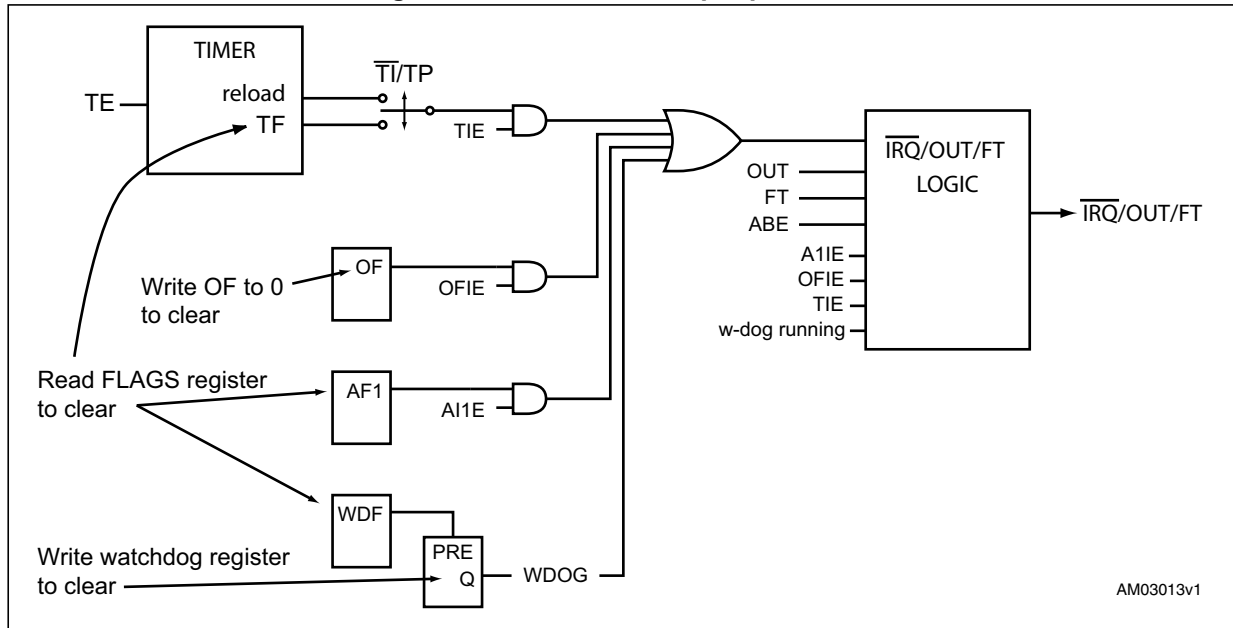

The timer, oscillator fail detect circuit, alarm 1, and watchdog are ORed together as the primary interrupt sources. The frequency test signal, FT, is used to enable a 512 Hz output on the $\overline{\text{IRQ/FT/OUT}}$ pin for calibrating the RTC. When not used as an interrupt or frequency test output, the pin can be used as a discrete logic output controlled by the OUT bit. The ABE bit is used to enable interrupts during backup mode.

Operating on V_{CC} , all four interrupt sources are available. During backup, the timer and watchdog are disabled, and the only interrupt sources are alarm 1 and the oscillator fail detect circuit.

3.14.1 Active mode operation on V_{CC}

On V_{CC}, the operation of the output circuit is as shown in *Table 11*.

Table 11. Priority for $\overline{\text{IRQ}}$ /FT/OUT pin when operating on V_{CC}

OUT ⁽¹⁾	FT ⁽²⁾	A1IE ⁽³⁾ + OFIE ⁽⁴⁾ + TIE ⁽⁵⁾ + watchdog ⁽⁶⁾ running	Pin	Comment
0	0	x	0	When OUT is 0 and FT is not enabled, OUT dominates and none of the interrupt sources have any effect.
0	1	x	512 Hz	When FT = 1 and OUT = 1 and no interrupts are enabled, the output will be the 512 Hz frequency test (FT) signal.
x	1	0		
1	x	1	$\overline{\text{IRQ}}$	When one or more interrupts are enabled, and OUT is a 1, the pin stays high until one of the interrupts is asserted.
1	0	0	1	When OUT is 1, FT is 0 and no interrupts are enabled, the pin is high.

1. OUT is bit 7 of register 08h (digital calibration).
2. FT is bit 6 of register 08h (digital calibration).
3. A1IE is bit 7 of register 0Ah (alarm 1, month).
4. OFIE is bit 7 of register 09h (watchdog).
5. TIE is bit 5 of register 11h (timer control).
6. The watchdog is controlled by register 09h (watchdog).

When OUT is 0 and FT is 0, the pin will be 0 regardless of whether any interrupts are enabled.

When FT is a 1, the 512 Hz signal will be output if OUT is 0 or if no interrupts are enabled.

The interrupt sources control the pin when OUT is 1 and one or more of the interrupts are enabled.

If OUT is 1, FT is 0 and no interrupts are enabled, then the pin will be 1.

3.14.2 Backup mode

In backup mode, the operation of the output circuit is as shown in [Table 12](#).

Table 12. Priority for $\overline{\text{IRQ}}/\text{FT}/\text{OUT}$ pin when operating in backup mode

OUT ⁽¹⁾	ABE ⁽²⁾	A1IE ⁽³⁾ + OFIE ⁽⁴⁾	Pin	Comment
x	0	x	1	When ABE is 0, the pin is 1 regardless of OUT or the interrupt sources.
1	x	0	1	When OUT is 1 and no interrupts are enabled, the pin is 1. (A1IE and OFIE are the only interrupts applicable in this mode).
0	1	x	0	When ABE is 1 and OUT is 0, OUT dominates and regardless of the interrupt sources.
1	1	1	$\overline{\text{IRQ}}$	When one or more interrupts are enabled, ABE is a 1, and OUT is a 1, the pin stays high until one of the interrupts is asserted.

1. OUT is bit 7 of register 08h (digital calibration).
2. ABE is bit 5 of register 0Ah (alarm 1, month).
3. A1IE is bit 7 of register 0Ah (alarm 1, month).
4. OFIE is bit 7 of register 09h (watchdog).

In backup mode, frequency test is disabled. Thus, the FT bit is a 'don't care'.

ABE enables interrupts in backup. If it is 0, the output pin is a 1 regardless of the other bits.

The pin is also a 1 when OUT is a 1 and no interrupts are enabled.

When OUT is 0 and ABE is a 1, the pin is 0 regardless of the interrupts.

Thus, in order to enable interrupts in backup mode, OUT must be a 1 and ABE must be a 1, and one or more of the interrupt enables must be a 1.

Simultaneous interrupts

Since more than one interrupt source can cause the $\overline{\text{IRQ}}/\text{FT}/\text{OUT}$ pin to go low, more than one interrupt may be pending when the microprocessor services the interrupt. Therefore, the application software should read the flags register (0Fh) to discern which condition or conditions are causing the pin to be asserted.

Also be aware that once a flag causes the pin to assert, other flags could subsequently also go true. Since the pin is already low due to the first, no additional output transition will occur. That is why the software must check the flags register.

Example: If the watchdog is in use and the oscillator fail detect interrupt is enabled, and the watchdog times out, the $\overline{\text{IRQ}}/\text{FT}/\text{OUT}$ pin will go low. If, in the intervening time before the processor services the interrupt, something disturbs the oscillator, such as a drop of moisture landing on the crystal pins, the OF bit will also be set. Thus, when the software services the interrupt, it must service both sources: it must re-initialize the watchdog *and* clear the OF bit in order to de-assert the $\overline{\text{IRQ}}/\text{FT}/\text{OUT}$ pin. By reading the flags register, the software will know both flags were set and that both need service.

3.15 Initial power-on defaults

Upon initial application of power to the device, the register bits will initially power-on in the state indicated in [Table 13](#) and [Table 14](#).

Table 13. Initial power-on default values (part 1)

Condition ⁽¹⁾	ST	CB1	CB0	OUT	FT	DCS ACS	Digital calib.	Analog calib.	OFIE	Watchdog ⁽²⁾	A1IE	SQWE	ABE
Initial power-up	0	0	0	1	0	0	0	0	0	0	0	1	0
Subsequent power-up ⁽³⁾⁽⁴⁾	UC	UC	UC	UC	0	UC	UC	UC	UC	0	UC	UC	UC

1. All other control bits power-up in an undetermined state
2. BMB0-BMB4, RB0, RB1
3. With battery backup
4. UC = Unchanged

Table 14. Initial power-up default values (part 2)

Condition ⁽¹⁾	RPT11-15	HT	OF	TE	T \bar{I} /TP	TIE	TD1	TD0	RS0	RS1-3	OTP	RPT21-25	AL2E
Initial power-up	0	1	1	0	0	0	1	1	1	0	0	0	0
Subsequent power-up ⁽²⁾⁽³⁾	UC	1	UC	0	UC	UC	UC	UC	UC	UC	UC	UC	UC

1. All other control bits power-up in an undetermined state
2. With battery backup
3. UC = Unchanged

3.16 OTP bit operation (SOX18 package only)

Using the factory-supplied analog calibration value

When the OTP (one time programmable) bit is set to a 1, the factory calibration value in the internal OTP register will be transferred to the analog calibration register (12h) and is “read only.” The OTP value is programmed by the manufacturer, and will contain the value necessary to achieve typically ± 5 ppm^(a) (V_{CC} only) at room temperature after two SMT reflows. This clock accuracy can be guaranteed to drift no more than ± 3 ppm the first year, and ± 1 ppm for each following year due to crystal aging.

If the OTP bit is set to 0, the analog calibration register will become a WRITE/READ register and function like an ordinary register, allowing the user to implement any desired value of analog calibration.

When the user sets the OTP bit, they need to wait for approximately 8 ms before the analog registers transfer the value from the OTP to the analog registers due to the OTP read operation.

a. Max. value = +12 ppm / -5 pmm based on limited data



4 Maximum ratings

Stressing the device above the rating listed in the “absolute maximum ratings” table may cause permanent damage to the device. These are stress ratings only and operation of the device at these or any other conditions above those indicated in the operating sections of this specification is not implied. Exposure to absolute maximum rating conditions for extended periods may affect device reliability.

Table 15. Absolute maximum ratings

Symbol	Parameter	Value ⁽¹⁾	Unit
T _{STG}	Storage temperature (V _{CC} off, oscillator off)	–55 to 125	°C
V _{CC}	Supply voltage	–0.3 to 7.0	V
T _{SLD} ⁽²⁾	Lead solder temperature for 10 seconds	260	°C
V _{IO}	Input or output voltages	–0.2 to V _{CC} +0.3	V
I _O	Output current	20	mA
P _D	Power dissipation	1	W
θ _{JA}	Thermal resistance, junction to ambient	QFN16	°C/W
		SOX18	

1. Data based on characterization results, not tested in production.

2. Reflow at peak temperature of 260 °C. The time above 255 °C must not exceed 30 seconds (according to JEDEC J-STD-020D).

5 DC and AC parameters

This section summarizes the operating and measurement conditions, as well as the DC and AC characteristics of the device. The parameters in the following DC and AC characteristic tables are derived from tests performed under the measurement conditions listed in the relevant tables. Designers should check that the operating conditions in their projects match the measurement conditions when using the quoted parameters.

Table 16. Operating and AC measurement conditions

Parameter	M41T93
Supply voltage (V_{CC})	2.38 V to 5.5 V
Ambient operating temperature (T_A)	-40 to +85 °C
Load capacitance (C_L , typical)	30 pF
Input rise and fall times	≤ 50 ns
Input pulse voltages	0.2 V_{CC} to 0.8 V_{CC}
Input and output timing ref. voltages	0.3 V_{CC} to 0.7 V_{CC}

Note: Output Hi-Z is defined as the point where data is no longer driven.

Figure 20. Measurement AC I/O waveform

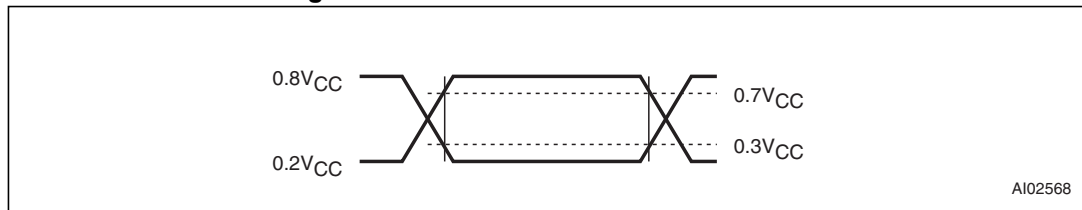

Table 17. Capacitance

Symbol	Parameter ⁽¹⁾⁽²⁾	Min	Max	Unit
C_{IN}	Input capacitance	-	7	pF
$C_{OUT}^{(3)}$	Output capacitance	-	10	pF

1. Effective capacitance measured with power supply at 3.6 V; sampled only, not 100% tested
2. At 25 °C, f = 1 MHz
3. Outputs deselected

Table 18. DC characteristics

Sym	Parameter	Test condition ⁽¹⁾		Min	Typ	Max	Unit
V _{CC}	Operating voltage (S)	-40 to 85 °C		3.00		5.50	V
	Operating voltage (R)	-40 to 85 °C		2.70		5.50	V
	Operating voltage (Z)	-40 to 85 °C		2.38		5.50	V
I _{LI}	Input leakage current	0 V ≤ V _{IN} ≤ V _{CC}				±1	μA
I _{LO}	Output leakage current	0 V ≤ V _{OUT} ≤ V _{CC}				±1	μA
I _{CC1}	Supply current SCL = 0.1V _{CC} /0.9V _{CC} SDO = open	f _{SCL} = 2 MHz				0.5	mA
		f _{SCL} = 5 MHz				1.0	mA
		f _{SCL} = 10 MHz				2.0	mA
I _{CC2}	Supply current (standby)	$\bar{E} = V_{CC};$	5.5 V		8	10	μA
		All inputs ≥ V _{CC} - 0.2 V; ≤ V _{SS} + 0.2 V	3.0 V		6.5		μA
V _{IL}	Input low voltage			-0.3		0.3V _{CC}	V
V _{IH}	Input high voltage			0.7V _{CC}		V _{CC} +0.3	V
V _{OL}	Output low voltage	\overline{RST}	V _{CC} /V _{BAT} = 3.0 V, I _{OL} = 1.0 mA			0.4	V
		SQW, $\overline{IRQ/FT/OUT}$	V _{CC} = 3.0 V, I _{OL} = 1.0 mA			0.4	V
		SDO	V _{CC} = 3.0 V, I _{OL} = 3.0 mA			0.4	V
V _{OH}	Output high voltage	V _{CC} = 3.0 V, I _{OH} = -1.0 mA (push-pull)		2.4			V
	Pull-up supply voltage (open drain)	$\overline{IRQ/FT/OUT}$				5.5	V
V _{BAT}	Backup supply voltage			1.8		5.5	V
I _{BAT}	Battery supply current	25 °C; V _{CC} = 0 V; OSC on; V _{BAT} = 3 V; 32 KHz off			365	450	nA

1. Valid for ambient operating temperature: T_A = -40 to 85 °C; V_{CC} = 2.38 V to 5.5 V (except where noted)

Figure 21. I_{CC2} vs. temperature

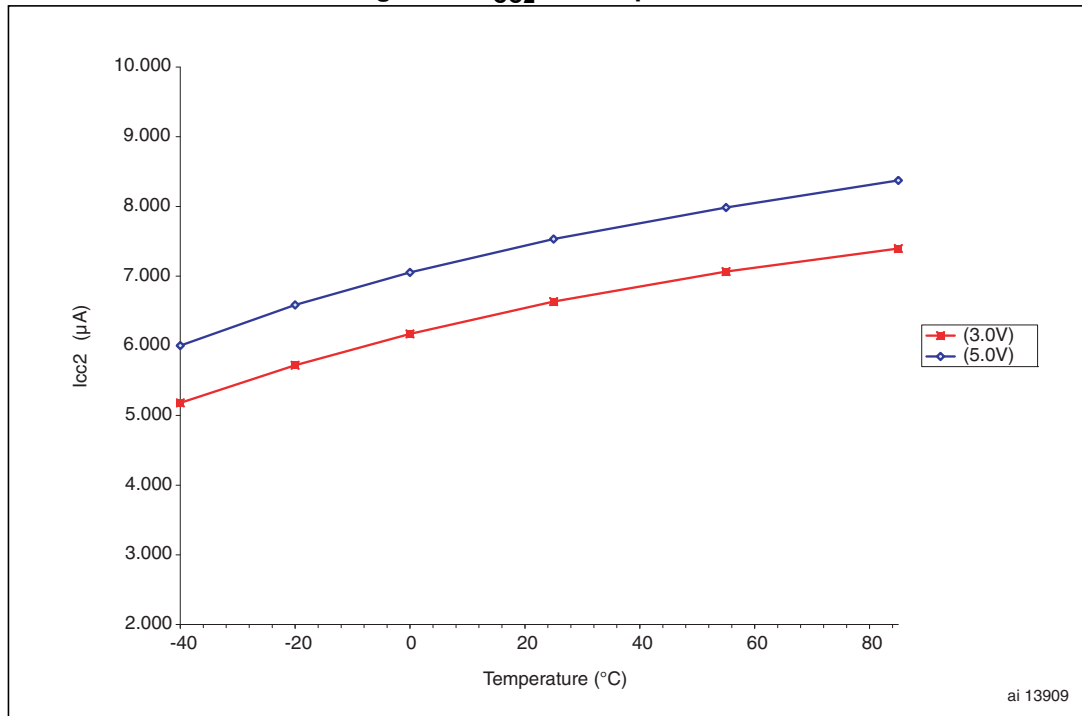

Table 19. Crystal electrical characteristics

Symbol	Parameter ⁽¹⁾⁽²⁾	Min	Typ	Max	Units
f _O	Resonant frequency	-	32.768		kHz
R _S	Series resistance	-		65 ⁽³⁾	kΩ
C _L	Load capacitance	-	12.5		pF

- Externally supplied if using the QFN16 package. STMicroelectronics recommends the Citizen CFS-145 (1.5 x 5 mm) and the KDS DT-38 (3 x 8 mm) for thru-hole, or the KDS DMX-26S (3.2 x 8 mm) or Micro Crystal MS3V-T1R (1.5 x 5 mm) for surface-mount, tuning fork-type quartz crystals.
- Load capacitors are integrated within the M41T93. Circuit board layout considerations for the 32.768 kHz crystal of minimum trace lengths and isolation from RF generating signals should be taken into account.
- Guaranteed by design.

Table 20. Oscillator characteristics

Symbol	Parameter ⁽¹⁾⁽²⁾	Conditions	Min	Typ	Max	Units
V _{STA}	Oscillator start voltage	≤4 s	2.0			V
t _{STA}	Oscillator start time	V _{CC} = V _{SO}			1	s
C _{XI} , C _{XO} ⁽¹⁾	Capacitor input, capacitor output			25		pF
	IC-to-IC frequency variation ⁽²⁾⁽³⁾		-10		+10	ppm

- With default analog calibration value (= 0)
- Reference value
- T_A = 25 °C, V_{CC} = 5.0 V

Figure 22. Power down/up mode AC waveforms

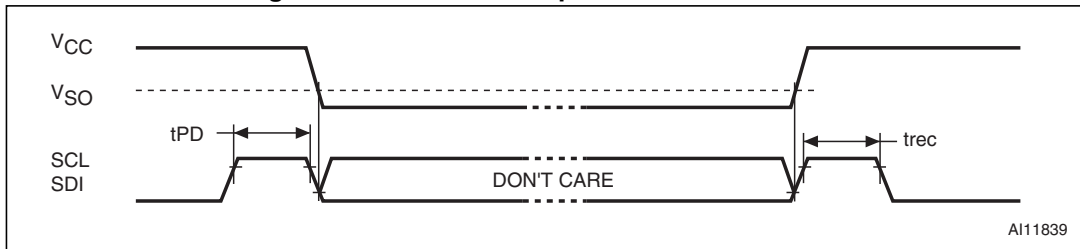

Table 21. Power down/up trip points DC characteristics

Sym	Parameter ⁽¹⁾⁽²⁾	Min	Typ	Max	Unit	
V _{RST}	Reset threshold voltage	S	2.85	2.93	3.0	V
		R	2.55	2.63	2.7	V
		Z	2.25	2.32	2.38	V
V _{SO}	Battery backup switchover	V _{RST}			V	
	Hysteresis	25			mV	
t _{rec}	Reset pulse width (V _{CC} rising)	140		280	ms	
	V _{CC} to reset delay, V _{CC} = (V _{RST} + 100 mV), falling to (V _{RST} - 100 mV; for V _{CC} slew rate of 10 mV/μs		2.5		μs	

1. All voltages referenced to V_{SS}
2. Valid for ambient operating temperature: T_A = -40 to 85 °C; V_{CC} = 2.38 to 5.5 V (except where noted)

Figure 23. Input timing requirements

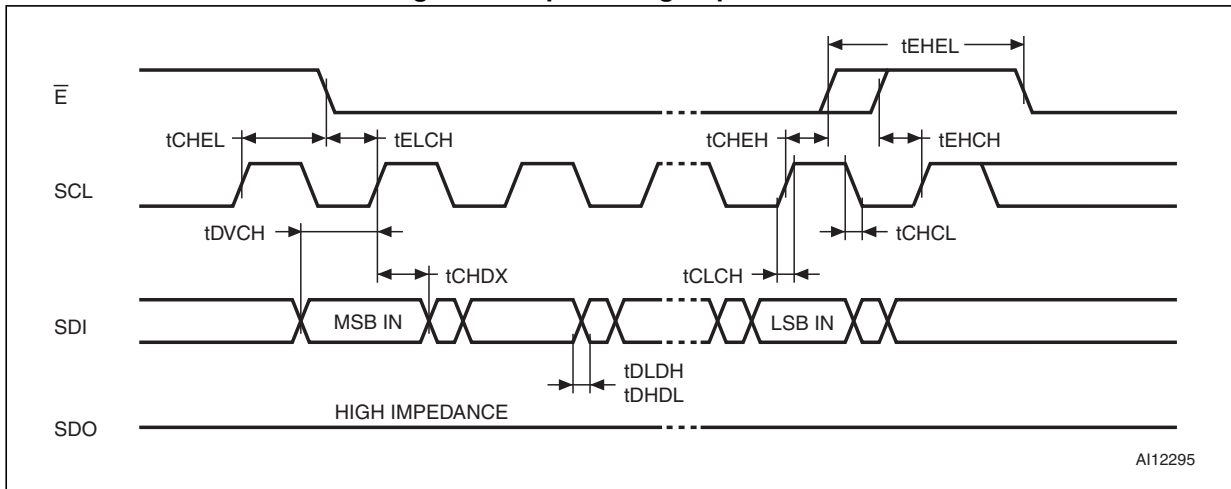

Figure 24. Output timing requirements

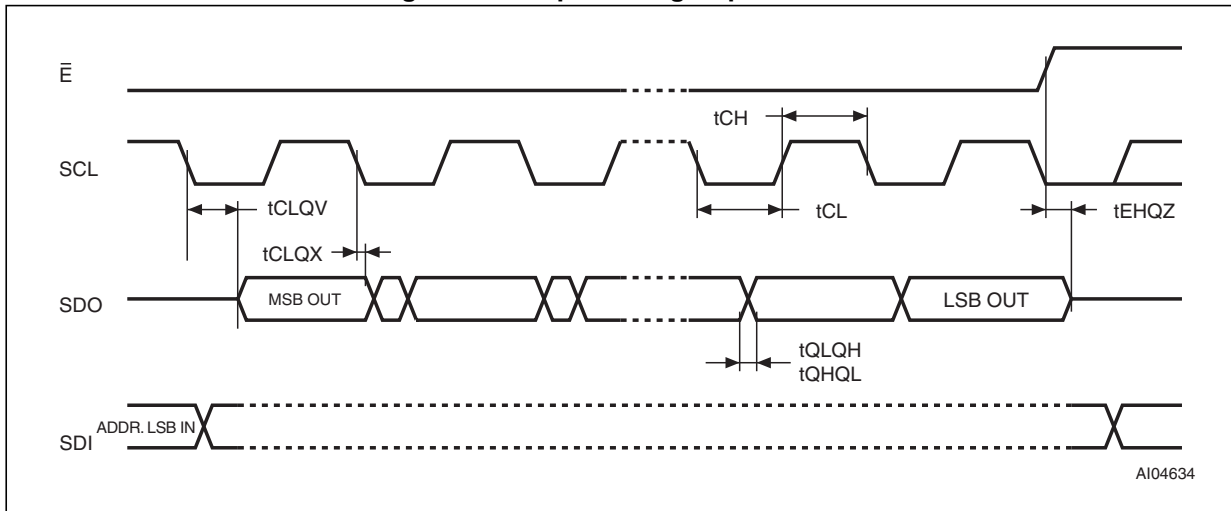

Table 22. AC characteristics

Sym	Parameter ⁽¹⁾	V _{CC} < 2.7 V		V _{CC} ≥ 2.7 V		Units
		Min	Max	Min	Max	
f _{SCL}	SCL clock frequency	D.C.	5	D.C.	10	MHz
t _{ELCH}	\bar{E} active setup time	90		30		ns
t _{EHCH}	\bar{E} not active setup time	90		30		ns
t _{EHEL}	\bar{E} deselect time	100		40		ns
t _{CHEH}	\bar{E} active hold time	90		30		ns
t _{CHEL}	\bar{E} not active hold time	90		30		ns
t _{CH} ⁽²⁾	Clock high time	90		40		ns
t _{CL} ⁽²⁾	Clock low time	90		40		ns
t _{CLCH} ⁽³⁾	Clock rise time		1		2	μs
t _{CHCL} ⁽³⁾	Clock fall time		1		2	μs
t _{DVCH}	Data in setup time	20		10		ns
t _{CHDX}	Data in hold time	30		10		ns
t _{EHQZ} ⁽³⁾	Output disable time		100		40	ns
t _{CLQV}	Clock low to output valid		60		40	ns
t _{CLQX}	Output hold time	0		0		ns
t _{QLQH} ⁽³⁾	Output rise time		50		40	ns
t _{QHQL} ⁽³⁾	Output fall time		50		40	ns

1. Valid for ambient operating temperature: T_A = -40 to 85 °C; V_{CC} = 2.38 to 5.5 V (except where noted)
2. t_{CH} and t_{CL} must never be lower than the shortest possible clock period, 1/f_{C(max)}
3. Value guaranteed by characterization, not 100% tested in production

6 Package mechanical data

In order to meet environmental requirements, ST offers these devices in different grades of ECOPACK[®] packages, depending on their level of environmental compliance. ECOPACK[®] specifications, grade definitions and product status are available at: www.st.com. ECOPACK[®] is an ST trademark.

Figure 25. QFN16 – 16-lead, quad, flat package, no lead, 4 x 4 mm body size, outline

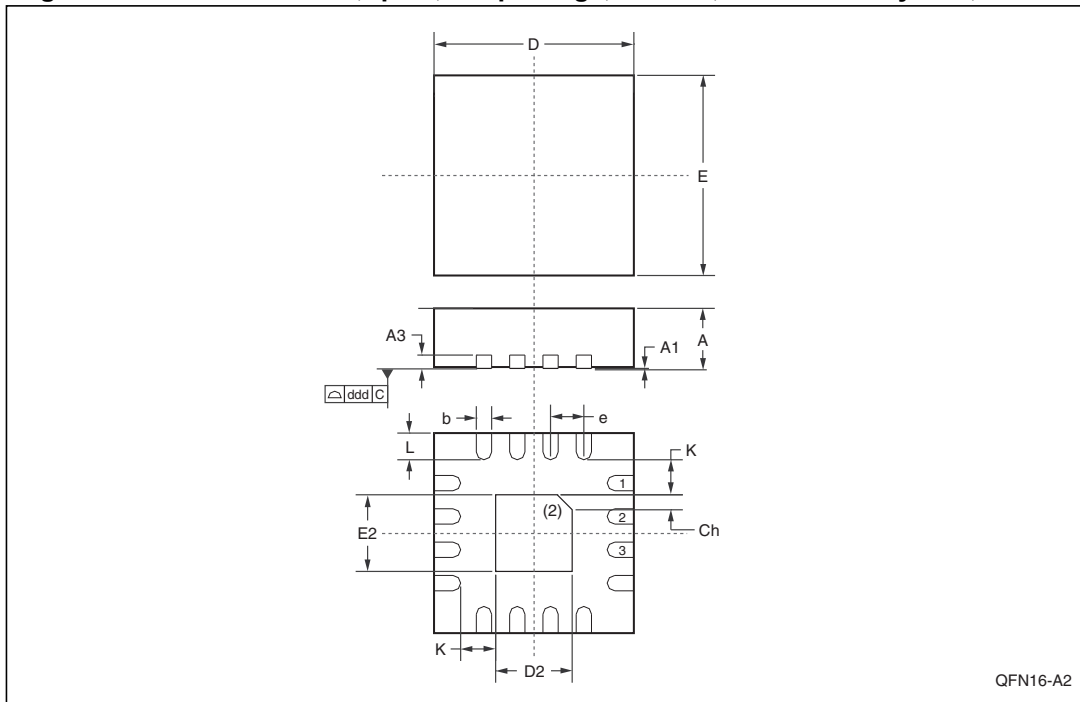

QFN16-A2

1. Drawing is not to scale
2. Substrate pad should be tied to V_{SS}

Table 23. QFN16 – 16-lead, quad, flat package, no lead, 4 x 4 mm body, mech. data

Sym	mm			inches		
	Typ	Min	Max	Typ	Min	Max
A	0.90	0.80	1.00	0.035	0.032	0.039
A1	0.02	0.00	0.05	0.001	0.000	0.002
A3	0.20	–	–	0.008	–	–
b	0.30	0.25	0.35	0.010	0.007	0.012
D	4.00	3.90	4.10	0.118	0.114	0.122
D2	–	2.50	2.80	0.067	0.061	0.071
E	4.00	3.90	4.10	0.118	0.114	0.122
E2	–	2.50	2.80	0.067	0.061	0.071
e	0.65	–	–	0.020	–	–
K	0.20	–	–	0.008	–	–
L	0.40	0.30	0.50	0.016	0.012	0.020
ddd	–	0.08	–	–	0.003	–
Ch	–	0.33	–	–	0.013	–
N	16			16		

Figure 26. QFN16 – 16-lead, quad, flat, no lead, 4 x 4 mm, recommended footprint

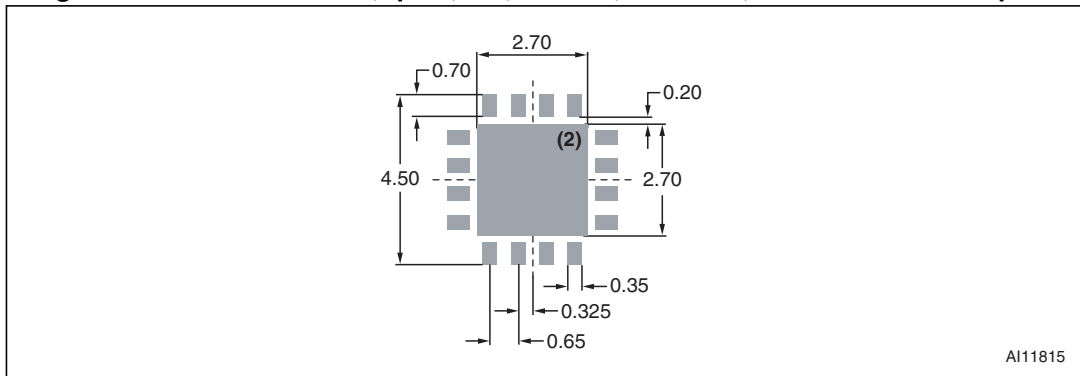

AI11815

1. Dimensions shown are in millimeters (mm)
2. Substrate pad should be tied to V_{SS}

Figure 27. 32 KHz crystal + QFN16 vs. VSOJ20 mechanical data

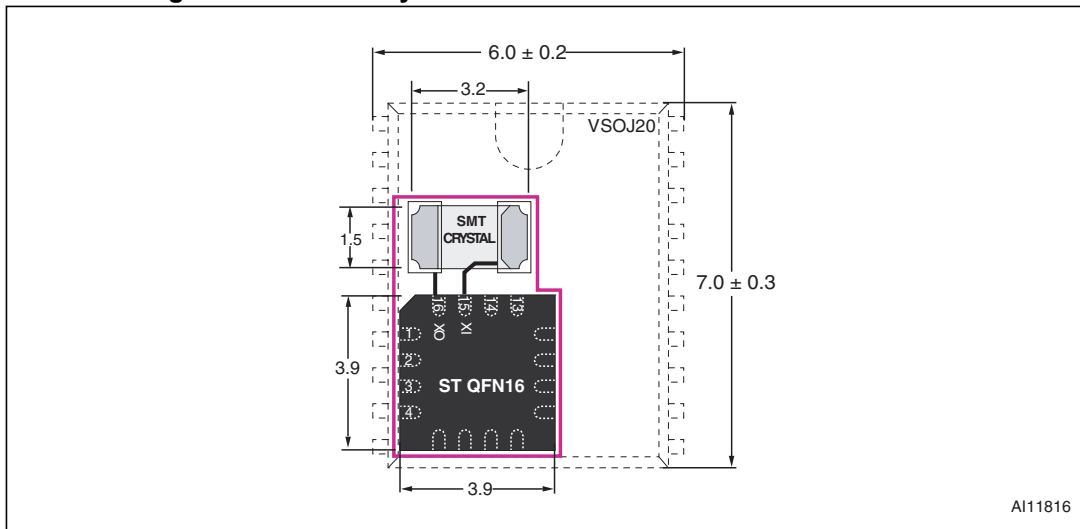

AI11816

Note: Dimensions shown are in millimeters (mm).

Figure 28. SOX18 – 18-lead plastic small outline, 300 mils, embedded crystal

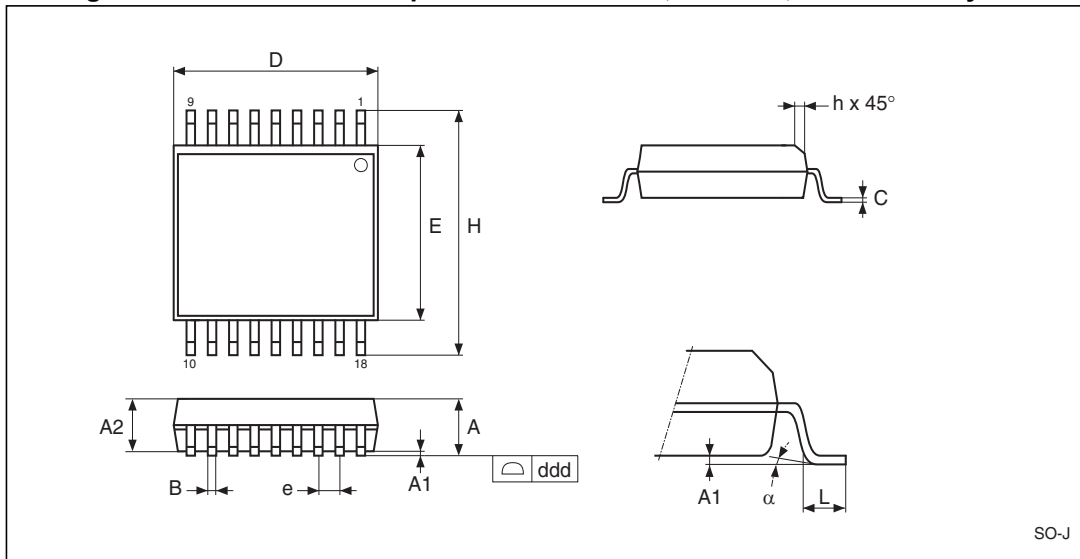

Note: Drawing is not to scale.

Table 24. SOX18 – 18-lead plastic SO, 300 mils, embedded crystal, pkg. mech. data

Sym	mm			inches		
	Typ	Min	Max	Typ	Min	Max
A	–	2.44	2.69	–	0.096	0.106
A1	–	0.15	0.31	–	0.006	0.012
A2	–	2.29	2.39	–	0.090	0.094
B	–	0.41	0.51	–	0.016	0.020
C	–	0.20	0.31	–	0.008	0.012
D	11.61	11.56	11.66	0.457	0.455	0.459
ddd	–	–	0.10	–	–	0.004
E	–	7.57	7.67	–	0.298	0.302
e	1.27	–	–	0.050	–	–
H	–	10.16	10.52	–	0.400	0.414
L	–	0.51	0.81	–	0.020	0.032
alpha	–	0°	8°	–	0°	8°
N	18			18		

7 Part numbering

Table 25. Ordering information

Example:	M41T	93	S	QA	6	F
Device family						
M41T						
Device type						
93						
Operating voltage						
S = $V_{CC} = 3.00$ to 5.5 V						
R = $V_{CC} = 2.70$ to 5.5 V						
Z = $V_{CC} = 2.38$ to 5.5 V						
Package						
QA = QFN16 (4 mm x 4 mm)						
MY ⁽¹⁾ = SOX18						
Temperature range						
6 = -40 °C to $+85$ °C						
Shipping method						
F = ECOPACK [®] package, tape & reel						

1. The SOX18 package includes an embedded 32,768 Hz crystal.

For other options, or for more information on any aspect of this device, please contact the ST sales office nearest you.

8 Revision history

Table 26. Document revision history

Date	Revision	Changes
12-Oct-2011	6	Updated <i>Features</i> , title, <i>Section 3.1: Clock data coherency</i> , <i>Section 3.2: Halt bit (HT) operation</i> ; added <i>Figure 9</i> , added footnote 2 to <i>Table 25: Ordering information</i> .
04-Sep-2013	7	Updated <i>Features</i> bullet concerning accuracy Added footnote 2 within <i>Figure 4</i> Updated <i>Figure 6</i> Updated <i>Section 2</i> and 2.2 Updated <i>Section 3</i> , 3.3, 3.4.1, 3.4.2, and <i>Section 3.5</i> Updated <i>Figure 13</i> Updated <i>Section 3.6</i> Textual update in <i>Figure 15</i> Removed figure entitled "Alarm interrupt reset waveform" Updated <i>Section 3.7</i> , 3.8, 3.8.1, <i>Table 7</i> and 8 Added <i>Figure 16</i> Removed section concerning $\overline{\text{TI}}/\text{TP}$ bit Updated <i>Section 3.8.2</i> and 3.8.3 Removed table entitled "Timer countdown value register bits (addr 11h)" Updated <i>Section 3.10</i> , 3.11 Added <i>Figure 18</i> Removed table entitled "Century bits examples" Removed section concerning output driver pin Updated <i>Section 3.12</i> and 3.13 Added <i>Section 3.14</i> and <i>Figure 19</i> , <i>Table 11</i> and 12 Updated <i>Section 3.16</i> Updated <i>Table 15</i> Updated test condition for V_{OL} in <i>Table 18</i> Removed section concerning crystal component suppliers Updated <i>Table 25</i> Minor textual updates throughout document
11-Nov-2013	8	Updated <i>Section 3.10: Battery low warning</i> and added <i>Figure 17</i> ; updated <i>Section 3.4.2: Analog calibration (programmable load capacitance)</i> and added <i>Section 3.4.3: Pre-programmed calibration value</i> ; updated <i>Section 3.16: OTP bit operation (SOX18 package only)</i> ; updated <i>Table 15</i>

Please Read Carefully:

Information in this document is provided solely in connection with ST products. STMicroelectronics NV and its subsidiaries ("ST") reserve the right to make changes, corrections, modifications or improvements, to this document, and the products and services described herein at any time, without notice.

All ST products are sold pursuant to ST's terms and conditions of sale.

Purchasers are solely responsible for the choice, selection and use of the ST products and services described herein, and ST assumes no liability whatsoever relating to the choice, selection or use of the ST products and services described herein.

No license, express or implied, by estoppel or otherwise, to any intellectual property rights is granted under this document. If any part of this document refers to any third party products or services it shall not be deemed a license grant by ST for the use of such third party products or services, or any intellectual property contained therein or considered as a warranty covering the use in any manner whatsoever of such third party products or services or any intellectual property contained therein.

UNLESS OTHERWISE SET FORTH IN ST'S TERMS AND CONDITIONS OF SALE ST DISCLAIMS ANY EXPRESS OR IMPLIED WARRANTY WITH RESPECT TO THE USE AND/OR SALE OF ST PRODUCTS INCLUDING WITHOUT LIMITATION IMPLIED WARRANTIES OF MERCHANTABILITY, FITNESS FOR A PARTICULAR PURPOSE (AND THEIR EQUIVALENTS UNDER THE LAWS OF ANY JURISDICTION), OR INFRINGEMENT OF ANY PATENT, COPYRIGHT OR OTHER INTELLECTUAL PROPERTY RIGHT.

ST PRODUCTS ARE NOT DESIGNED OR AUTHORIZED FOR USE IN: (A) SAFETY CRITICAL APPLICATIONS SUCH AS LIFE SUPPORTING, ACTIVE IMPLANTED DEVICES OR SYSTEMS WITH PRODUCT FUNCTIONAL SAFETY REQUIREMENTS; (B) AERONAUTIC APPLICATIONS; (C) AUTOMOTIVE APPLICATIONS OR ENVIRONMENTS, AND/OR (D) AEROSPACE APPLICATIONS OR ENVIRONMENTS. WHERE ST PRODUCTS ARE NOT DESIGNED FOR SUCH USE, THE PURCHASER SHALL USE PRODUCTS AT PURCHASER'S SOLE RISK, EVEN IF ST HAS BEEN INFORMED IN WRITING OF SUCH USAGE, UNLESS A PRODUCT IS EXPRESSLY DESIGNATED BY ST AS BEING INTENDED FOR "AUTOMOTIVE, AUTOMOTIVE SAFETY OR MEDICAL" INDUSTRY DOMAINS ACCORDING TO ST PRODUCT DESIGN SPECIFICATIONS. PRODUCTS FORMALLY ESCC, QML OR JAN QUALIFIED ARE DEEMED SUITABLE FOR USE IN AEROSPACE BY THE CORRESPONDING GOVERNMENTAL AGENCY.

Resale of ST products with provisions different from the statements and/or technical features set forth in this document shall immediately void any warranty granted by ST for the ST product or service described herein and shall not create or extend in any manner whatsoever, any liability of ST.

ST and the ST logo are trademarks or registered trademarks of ST in various countries.

Information in this document supersedes and replaces all information previously supplied.

The ST logo is a registered trademark of STMicroelectronics. All other names are the property of their respective owners.

© 2013 STMicroelectronics - All rights reserved

STMicroelectronics group of companies

Australia - Belgium - Brazil - Canada - China - Czech Republic - Finland - France - Germany - Hong Kong - India - Israel - Italy - Japan - Malaysia - Malta - Morocco - Philippines - Singapore - Spain - Sweden - Switzerland - United Kingdom - United States of America

www.st.com

Mouser Electronics

Authorized Distributor

Click to View Pricing, Inventory, Delivery & Lifecycle Information:

[STMicroelectronics:](#)

[M41T93ZMY6F](#) [M41T93SMY6F](#) [M41T93RMY6F](#) [M41T93RQA6F](#) [M41T93ZQA6F](#) [M41T93SQA6F](#)