

Features

- Two switch model
- Independent switch adjustment, no tools needed
- Two 1/2" conduit / cable entrances
- Separate isolated wiring chambers
- Non-corrosive pressure connection
- Non-Conductive Enclosure
- VdS version available



NOTICE

This document contains important information on the installation and operation of PS15 pressure switches. Please read all instructions carefully before beginning installation. A copy of this document is required by NFPA 72 to be maintained on site.

Installation

The Potter PS15 Series Supervisory Pressure Actuated Switches are designed primarily to detect an increase and/or decrease from normal system pressure in automatic fire sprinkler systems. Typical applications are: air/nitrogen supervision in Dry pipe and pre-action systems, pressure tanks, air supplies, and water supplies. The PS15 has two switches. The Low switch is factory set to activate at approximately 10 psi (0,35 bar) on a decrease in pressure. The High switch is factory set to activate at approximately 20 psi (1,4 bar) on an increase in pressure. See section heading Adjustments and Testing if other than factory set point is required.

1. Connect the PS15 to the system side of any shutoff or check valve.
2. Apply Teflon tape to the threaded male connection on the device. (Do not use pipe dope)
3. Device should be mounted in the upright position. (Threaded connection down)
4. Tighten the device using a wrench on the flats on the device.

Wiring Instructions

1. Remove the tamper resistant screw with the special key provided.
2. Carefully place a screwdriver on the edge of the knockout and sharply apply a force sufficient to dislodge the knockout plug. See Fig. 9.
3. Run wires through an approved conduit connector and affix the connector to the device. A NEMA-4 rated conduit fitting is required for outdoor use.
4. Connect the wires to the appropriate terminal connections for the service intended. See Figures 2,4,5 and 6. See Fig. 7 for two switch one conduit wiring.

Technical Specifications

Conduit Entrances	Two knockouts provided for 1/2" conduit. Individual switch compartments and ground screw suitable for dissimilar voltages
Contact Ratings	SPDT (Form C) 10.1 Amps at 125/250VAC, 2.0 Amps at 30VDC
Cover Tamper	Cover incorporates tamper resistant fastener that requires a special key for removal. One key is supplied with each device.
Differential	Typical 1 lb. at 5 psi (,07 at 0,34 bar) 3 lbs at 30 psi (,21 at 2,1 bar)
Dimensions	3.78"(9,6cm)Wx3.20"(8,1cm)Dx4.22"(10,7cm)H
Enclosure	Cover: Weather/UV/Flame Resistant High Impact Composite Base: Die Cast All parts have corrosion resistant finishes
Environmental Limitations	NEMA 4/IP66 Rated Enclosure - indoor or outdoor when used with NEMA 4 conduit fittings. Temperature range: -40°F to 140°F (-40°C to 60°C)
Factory Adjustment	LOW switch operates at approximately 10 psi (0,7 bar) on decreasing pressure. HIGH switch operates at approximately 20 psi (1,4 bar) on increasing pressure
Maximum System Pressure	300 psi (20,68 bar)
Pressure Connection	Nylon 1/2" NPT male
Pressure Range	5-30 psi (0,35 - 2,07 bar)
Service Use	NFPA 13, 13D, 13R, 72

*Specifications subject to change without notice.

Adjustment and Testing

The operation of the pressure supervisory switch should be tested upon completion of installation and periodically thereafter in accordance with the applicable NFPA codes and standards and/or the authority having jurisdiction (manufacturer recommends quarterly or more frequently).

Note: Testing the PS15 may activate other system connected devices.

The use of a Potter BVL (see product bulletin 5400799 for details) is recommended to facilitate setting and testing of the PS15 pressure switch. When a BVL (bleeder valve) is used, the pressure to the switch can be isolated and bled from the exhaust port on the BVL without affecting the supervisory pressure of the entire system. See Fig. 3

The operation point of the PS15 Pressure Switch can be adjusted to any point between 5 and 30 psi (0,35 - 2,07 bar) by turning the adjustment knob(s) clockwise to raise the actuation point and counter clockwise to lower the actuation point. In the case of the PS15-2, both switches operate independently of each other. Each switch may be independently adjusted to actuate at any point across the switch adjustment range. Initial adjustment can be made with a visual reference from the top of the adjustment knob across to the printed scale on the switch bracket. Final adjustments should be verified with a pressure gauge.

Dimensions

Fig 1

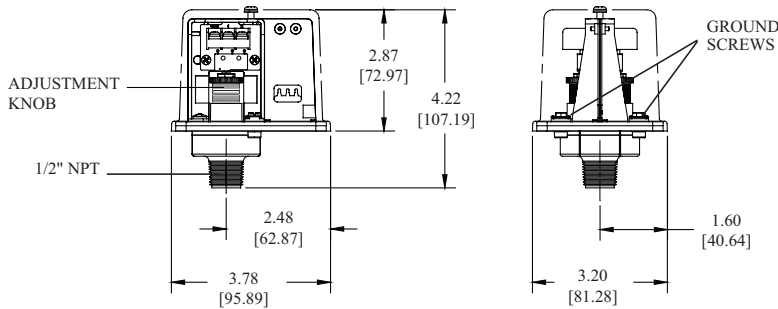

NOTE: To prevent leakage, apply Teflon tape sealant to male threads only.

DWG# 930-1

Switch Clamping Plate Terminal

Fig 2

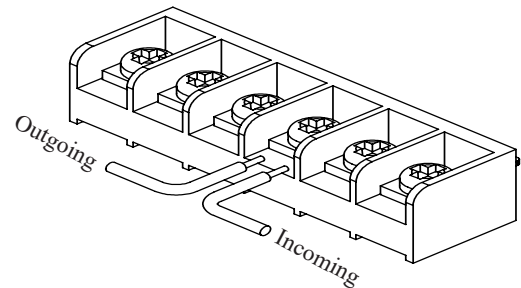

WARNING

An uninsulated section of a single conductor should not be looped around the terminal and serve as two separate connections. The wire must be severed, thereby providing supervision of the connection in the event that the wire becomes dislodged from under the terminal.

Typical Sprinkler Applications

Fig 3

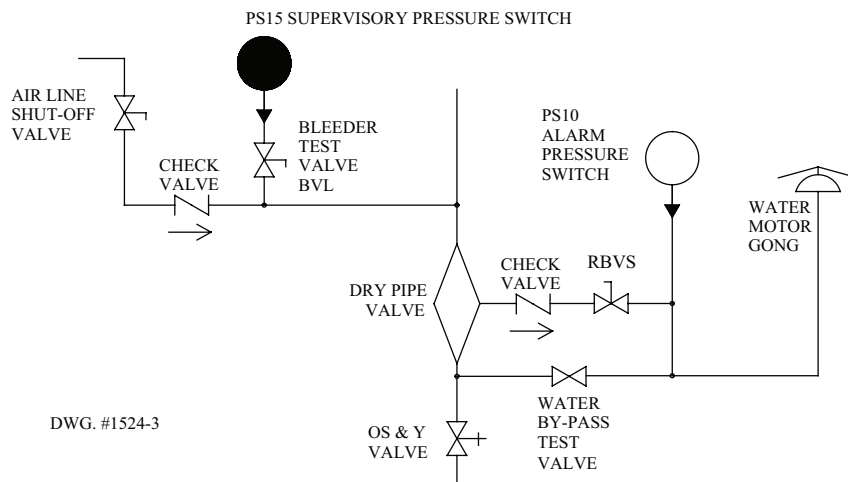

CAUTION

Closing of any shutoff valves between the alarm check valve and the PS10 will render the PS10 inoperative. To comply with IBC, IFC, and NFPA-13, any such valve shall be electrically supervised with a supervisory switch such as Potter Model RBVS.

Typical Connections

Fig 4

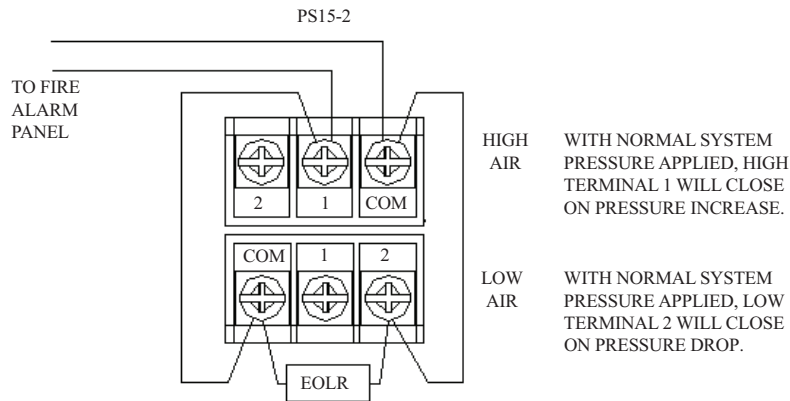

DWG# 1524-4

Low Pressure Signal Connection

Fig 5

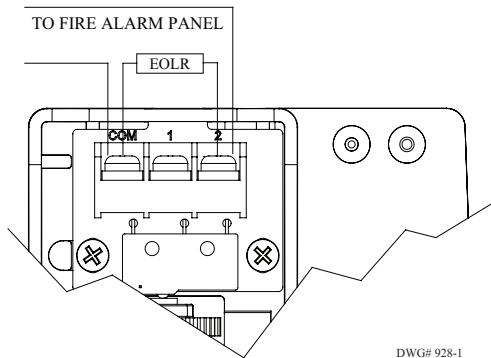

DWG# 928-1

One Conduit Wiring

Fig 7

Break out thin section of divider to provide path for wires when wiring both switches from one conduit entrance.

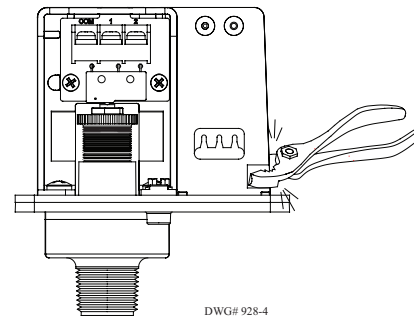

High Pressure Signal Connection

Fig 6

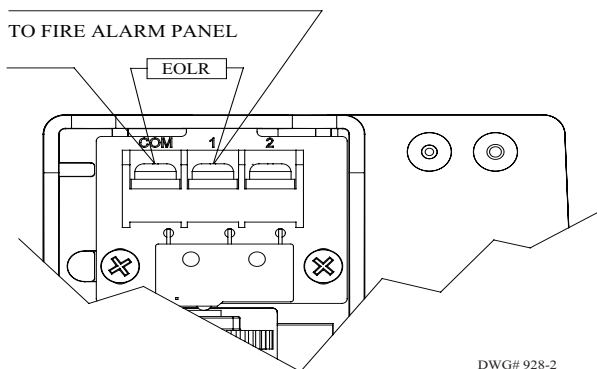

DWG# 928-2

Changing Pressure

Fig 8

Low Pressure Switch

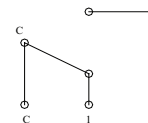

Terminal

C: Common

1. Closed when installed under normal system pressure.
2. Open when installed under normal system pressure. Closes on pressure drop. Use for low air signal.

High Pressure Switch

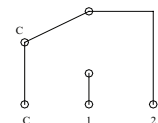

Terminal

1. Open when installed under normal system pressure. Closes on increase in pressure. Use for high air signal.
2. Closed under normal system pressure.

Removing Knockouts

Fig 10

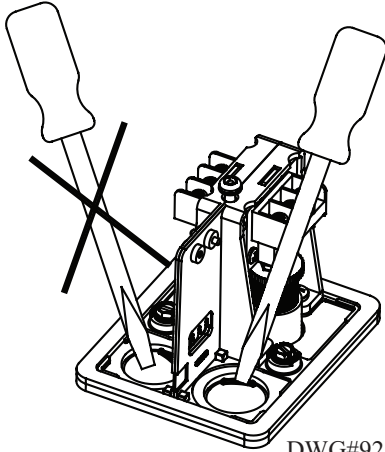

Engineer/Architect Specifications Pressure Type Waterflow Switch

Pressure type supervisory switches; shall be a Model PS15 as manufactured by Potter Electric Signal Company, St. Louis, MO., and shall be installed on the fire sprinkler system as shown and or specified herein.

Switches shall be provided with a 1/2" NPT male pressure connection to be connected into the air supply line on the system side of any shut-off valve. A Model BVL bleeder valve as supplied by Potter Electric Signal Company of St. Louis, MO., or equivalent shall be connected in line with the PS15 to provide a means of testing the operation of the supervisory switch. (See Fig. 3)

The switch unit shall contain SPDT (Form C) switch(es). The low switch shall be factory set to activate at 10 psi (0,7 bar) on pressure decrease. The high switch shall be factory set to activate at 20 psi (1,4 bar) on a pressure increase.

Switch contacts shall be rated at 10.1 Amps at 125/250VAC and 2.0 Amps at 30VDC. The units shall have a maximum pressure rating of 300 psi (20,68 bar) and shall be adjustable from 5 to 30 psi (0,35 to 2,07 bar).

Pressure switches shall have two conduit entrances, one for each individual switch compartment to facilitate the use of dissimilar voltages for each individual switch.

The cover of the pressure switch shall be Weather/UV/Flame Resistant High Impact Composite with rain lip and shall attach with one tamper resistant screw. The pressure switch shall be suitable for indoor or outdoor service with a NEMA-4/IP66 rating.

The pressure switch shall be UL, cUL, and CSFM listed, FM approved, LPCB Approved, and NYMEA accepted.

WARNING

- Installation must be performed by qualified personnel and in accordance with all national and local codes and ordinances.
- Shock hazard. Disconnect power source before servicing. Serious injury or death could result.
- Read all instructions carefully and understand them before starting installation. Save instructions for future use. Failure to read and understand instructions could result in improper operation of device resulting in serious injury or death.
- Risk of explosion. Not for use in hazardous locations. Serious injury or death could result.

CAUTION

- Do not tighten by grasping the switch enclosure. Use wrenching flats on the bushing only. Failure to install properly could damage the switch and cause improper operation resulting in damage to equipment and property.
- To seal threads, apply Teflon tape to male threads only. Using joint compounds or cement can obstruct the pressure port inlet and result in improper device operation and damage to equipment.
- Do not over tighten the device, standard piping practices apply.

Ordering Information

Model	Description	Part Number
PS15-2	Pressure switch with two sets SPDT contacts	1340415
Hex Key		5250062
Cover Tamper Switch Kit		0090200
BVL	Bleeder Valve	1000018

Tamper

Cover incorporates tamper resistant fastener that requires a special key for removal. One key is supplied with each device. For optional cover tamper switch kit, order Stock No. 0090200. See bulletin #5401200 PSCTSK.

NOTICE

Pressure switches have a normal service life of 10-15 years. However, the service life may be significantly reduced by local environmental conditions.

Mouser Electronics

Authorized Distributor

Click to View Pricing, Inventory, Delivery & Lifecycle Information:

[AMSECO:](#)

[PS15-2](#)