

Compact Photoelectric Sensor

CX-400 Series

MEUEN-CX400 V2.2

Thank you for purchasing products from Panasonic. Please read this Instruction Manual carefully and thoroughly for the correct and optimum use of this product. Kindly keep this manual in a convenient place for quick reference.

⚠ WARNING

- Never use this product as a sensing device for personnel protection.
- In case of using sensing devices for personnel protection, use products which meet laws and standards, such as OSHA, ANSI or IEC etc., for personnel protection applicable in each region or country.

1 CAUTIONS

- This product is designed for industrial use only.
- Make sure to carry out wiring with the power OFF.
- Do not use this product in an environment with inflammable or explosive gas.
- Incorrect wiring will damage the sensor.
- Verify that the supply voltage including the ripple is within the rating.
- If power is supplied from a commercial switching regulator, ensure that the frame ground (F.G.) terminal of the power supply is connected to an actual ground.
- In case noise generating equipment (switching regulator, inverter motor, etc.) is used in the vicinity of this product, connect the frame ground (F.G.) terminal of the equipment to an actual ground.
- Do not run the wires together with high-voltage lines or power lines or put them in the same raceway. This can cause malfunction due to induction.
- Do not use during the initial transient time (50ms) after the power supply is switched on.
- This sensor is suitable for indoor use only.
- You can extend the cable up to 100m max. with 0.3mm² or more cable (thru-beam type, both emitter and receiver). However, in order to reduce noise, make the wiring as short as possible. To comply with the requirements for the Korean S-Mark, the power supply line must be 10m or less.
- Do not apply stress directly to the sensor cable joint by forcibly bending or pulling.
- Do not use this sensor in places having excessive vapor, dust, etc., or where it may come in direct contact with water or corrosive gas.
- Take care that the sensor does not come in direct contact with water, oil, grease, or organic solvents such as thinners, etc.
- Never disassemble or modify the product.

2 PART NAMES

Standard type

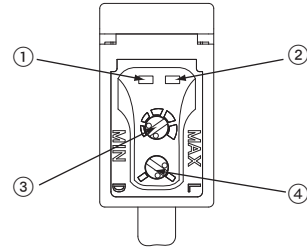

Basic type

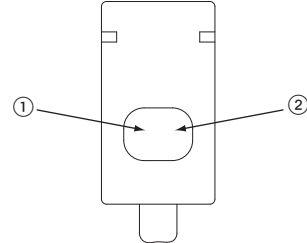

Thru-beam emitter for standard and basic types

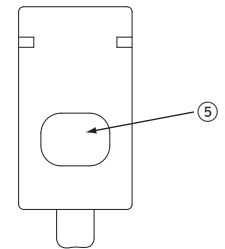

No.	Part	Description
①	Stability indicator (green)	Lights up under the stable Light or stable Dark condition.
②	Operation indicator (orange)	Reflective type, thru-beam receiver: lights up when the sensor output is ON.
③	Sensitivity adjuster	Reflective type, thru-beam receiver: sensing range increased when turned clockwise. See "SENSITIVITY ADJUSTMENT" on page 4.
④	Operation mode switch	Reflective type, thru-beam receiver: • L: Light-ON Light-ON mode is obtained when the operation mode switch is turned fully clockwise (L). • D: Dark-ON Dark-ON mode is obtained when the operation mode switch is turned fully counterclockwise (D).
⑤	Power indicator (green)	Lights up when power in ON.

3 CONNECTOR CABLES

Connector cables for the M12 pigtailed type

Type	Model no.	Cable length
2-core type	CN-22-C2	2m
	CN-22-C5	5m
4-core type	CN-24-C2	2m
	CN-24-C5	5m

Connector cables for the M8 connector type

Type	Model no.	Cable length
Straight type	CN-24A-C2	2m
	CN-24A-C5	5m
Elbow type	CN-24AL-C2	2m
	CN-24AL-C5	5m

Two sets of cables are required for the thru-beam type sensor.

4 I/O CIRCUIT DIAGRAMS

The following symbols are used in this section.

Symbol	Meaning
D	Reverse supply polarity protection diode
Z _D	Surge absorption zener diode
Tr	NPN / PNP output transistor

Pin assignment

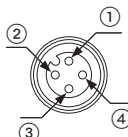
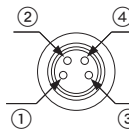
M12 pigtailed type	Terminal name	M8 connector type
	1) +V 2) Not connected 3) 0V 4) Output (see note)	

Only the thru-beam receiver incorporates the output.

NPN output type

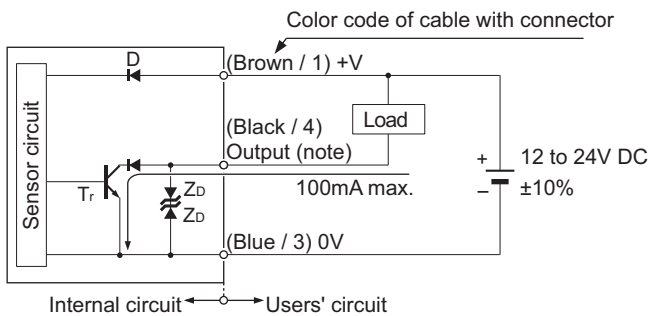

Only the thru-beam receiver incorporates the output.

PNP output type

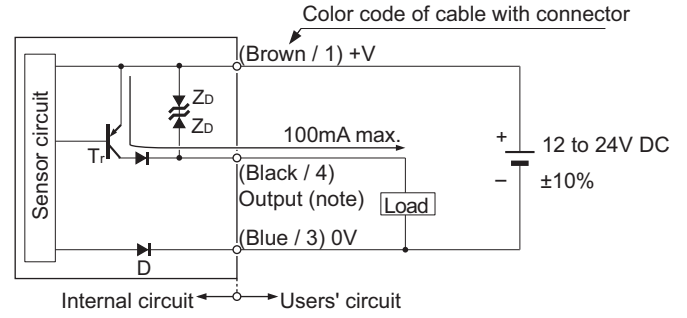

Only the thru-beam receiver incorporates the output.

5 MOUNTING AND ADJUSTING

Mount the sensor with a tightening torque of 0.5N·m or less.

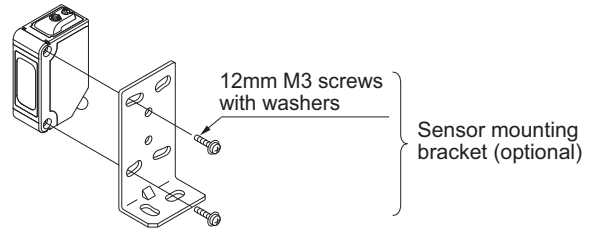

Thru-beam type sensor

- Set the operation mode switch to the Light-ON mode position (L side).
- Placing the emitter and the receiver face to face along a straight line. Move the emitter up, down, left and right to determine where light is received with the help of the receiver's operation indicator (orange). Set the emitter in the middle of this area.
- Adjust the angle of the emitter by twisting it up, down, left and right.
- In a similar manner, adjust the angle of the receiver.
- Check that the stability indicator (green) lights up.
- Choose the desired operation mode, Light-ON or Dark-ON, with the operation mode switch.

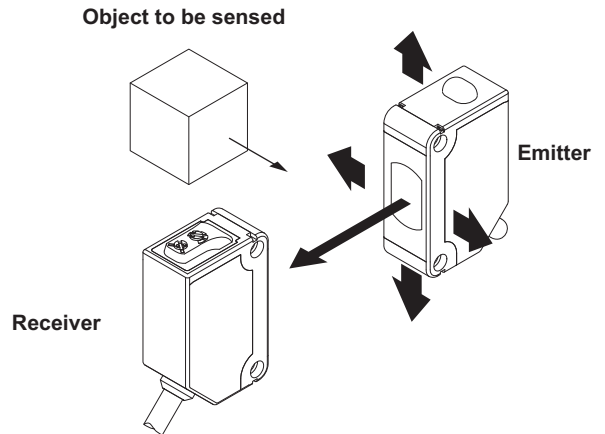

Installation interval

When mounting 2 or more sets of thru-beam type sensors side by side, they must be separated by a certain interval to prevent interference.

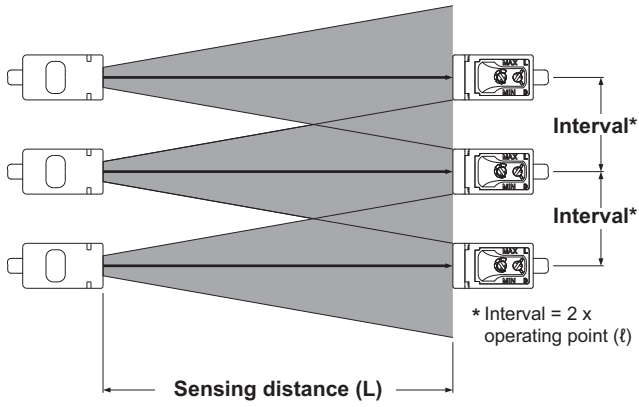

Diagrams for establishing the operating point (ℓ), typical:

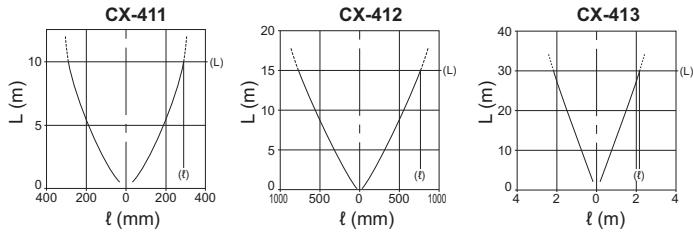

For example:

Model no.	Sensing distance (L)	Installation interval $2 \times \ell$
CX-411	10m	Approx. 590mm or more
CX-412	15m	Approx. 1,580mm or more
CX-413	30m	Approx. 4.35m or more

Retroreflective type sensor

Make sure to mount the sensor and the reflector at least 0.1mm apart.

- Set the operation mode switch to the Light-ON mode position (L side).
- Placing the sensor and the reflector face to face along a straight line. Move the reflector up, down, left and right to determine where light is received the help of the operation indicator (orange). Set the reflector in the middle of this area.
- Adjust the angle of the reflector by twisting it up, down, left and right.
- In a similar manner, adjust the angle of the sensor.
- Check that the stability indicator (green) lights up.
- Choose the desired operation mode, Light-ON or Dark-ON, with the operation mode switch.

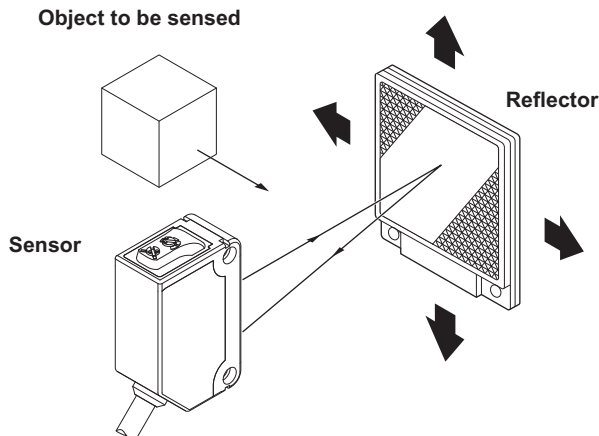

When sensing glossy objects with CX-493 or transparent objects with CX-48

These measures are not necessary for the retroreflective type with polarizing filters CX-491.

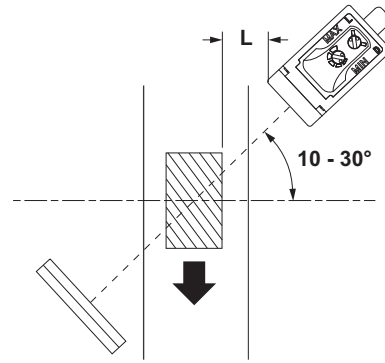

- Make sure the parallel distance (L) between the sensor and the object being sensed is great enough. Otherwise light might be reflected and erroneously detected by the sensor.
- Install the sensor at an angle of 10 to 30° to the object being sensed.

When sensing transparent objects with CX-48

- For optimum sensing, the distance should be the same between the transparent object being sensed and the sensor and the transparent object and the reflector. Otherwise, sensing may be unstable.

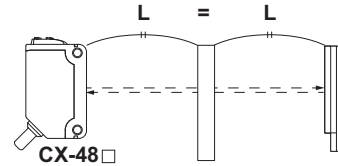

- When the sensor detects an irregular plastic receptacle or glass bottle, the received light intensity may differ with the sensing position or direction. Adjust the sensitivity after confirming the stable sensing condition by turning the sensing object, etc.
- If the object is a transparent cylinder, feed it in a standing, not a lying, position.

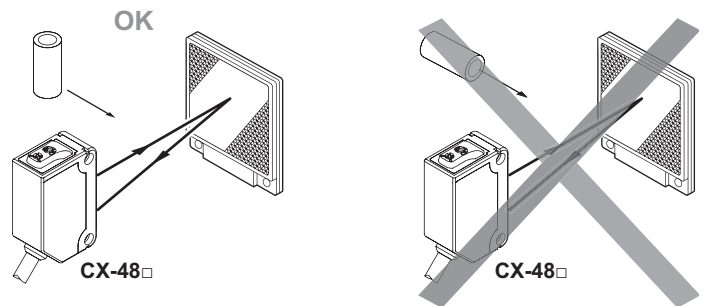

6 SENSITIVITY ADJUSTMENT

To understand sensitivity adjustment, you must first understand the difference between the “light received” and the “dark” condition.

Do not confuse the “light received” and “dark” condition with the operation modes “Light-ON” and “Dark-ON”!

	Light received condition	Dark condition
Thru-beam		
Retroreflective		
Diffuse reflective		

Relationship between output and indicators

Light-ON			Dark-ON			
Stability indicator	Operation indicator	Output	Sensing condition	Output	Operation indicator	Stability indicator
☀	☀	ON	Stable light	OFF	●	☀
●	☀	ON	Unstable light	OFF	●	●
☀	●	OFF	Unstable dark	ON	☀	●
☀	●	OFF	Stable dark	ON	☀	☀

☀ = lit, ● = unlit

🔧 Use a standard screwdriver and turn the adjuster slowly. Using excessive force will damage the adjuster.

This procedure assumes that “Light-ON” is set for the operation mode.



If “Dark-ON” is the operation mode, the output will behave the other way around!

Step	Sensitivity adjuster	Description
1		Turn the sensitivity adjuster fully counter-clockwise to the minimum sensitivity position, MIN.
2		In the “light received” condition, turn the sensitivity adjuster slowly clockwise to find point A where the sensor output turns ON.*1
3		In the “dark” condition, turn the sensitivity adjuster clockwise until the sensor output turns ON.*1 Turn it back slowly to confirm point B, where the sensor output just turns OFF.*1 If the sensor output does not turn ON even when the sensitivity adjuster is turned fully clockwise, point B is the position at MAX.
4		The position exactly between points A and B is the optimum sensing position.

*1 Remember, this only applies if the operation mode is Light-ON.

7 AUTOMATIC INTERFERENCE PREVENTION FUNCTION

🔧 This function is not available for the thru-beam type sensor. See “INTERFERENCE PREVENTION FILTERS” on page 5.

The automatic interference prevention function allows you to mount up to two sets of sensors next to each other.

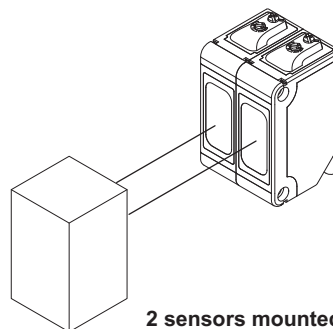

8 RETROREFLECTIVE TYPE SENSOR WITH POLARIZING FILTERS

As light is polarized by a transparent film or membrane, CX-491□ may not detect an object covered or wrapped by transparent film. Such objects include, for example:

- Can wrapped by clear film
- Aluminum sheet covered by plastic film
- Gold or silver (glossy) labels or wrapping paper

In such cases, take the following steps.

1. Tilt the sensor with respect to the object to be sensed.
2. Reduce the sensitivity.
3. Increase the distance between the sensor and the object to be sensed.

9 SLIT MASKS

☛ The slit mask is only available for the thru-beam type sensor.

Optional slit masks help the sensor detect small objects. However, the sensing range is reduced.

Type	Model no.	Slit size
Round slit mask	OS-CX-05	∅ 0.5mm
	OS-CX-1	∅ 1mm
	OS-CX-2	∅ 2mm
Rectangular slit mask	OS-CX-05 x 6	0.5 × 6mm
	OS-CX-1 x 6	1 × 6mm
	OS-CX-2 x 6	2 × 6mm

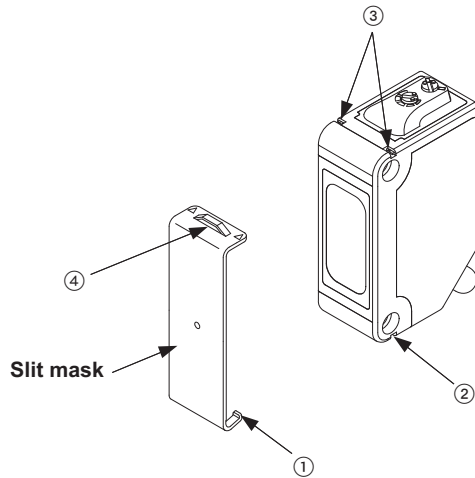

How to mount

1. Insert the hook ① into the bottom groove ②.
2. Press the slit mask until it snaps into the grooves ③ on the top of the main unit.

How to remove

1. Insert a screw driver into the tab ④.
2. Lift and remove carefully.

☛ For detailed information on the sensing distance and minimum size of the sensing object, please refer to the [CX-400 Series User's Manual](#).

10 INTERFERENCE PREVENTION FILTERS

☛ Interference prevention filters are only available for the thru-beam type sensor.

By mounting interference prevention filters, two sets of thru-beam type sensors can be mounted close together. However, the sensing range is reduced.

The filters can be mounted using the same method as for slit masks. For details, see page 5, section 9, SLIT MASKS.

For interference prevention to work, the following conditions must be met.

- The two sets of sensors must be fitted with different types of interference prevention filters.
- Filters must be mounted on emitters and receivers.

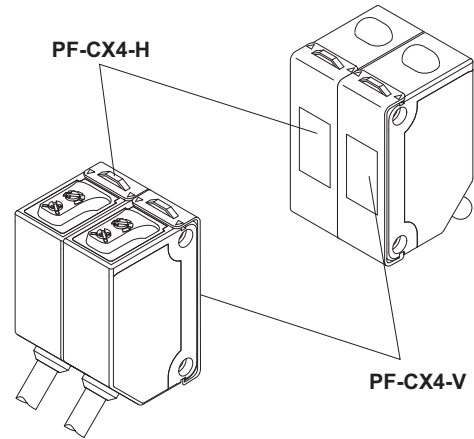

Model no.	Direction of thru-beam axis	Color of the bracket
PF-CX4-H	Horizontal	Light brown
PF-CX4-V	Vertical	Silver

☛ The model no. is not shown on the interference prevention filters. Take care when mounting them on the sensors.

11 DIMENSIONS

The basic dimensions of the sensor head are 11.2 x 31.0 x 20.0mm (WxHxD).

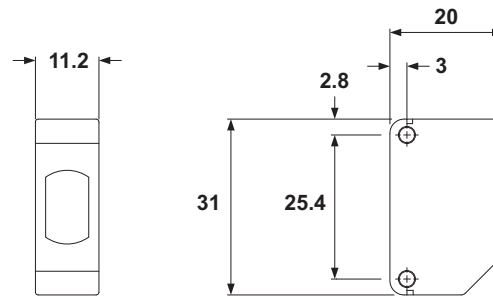

☛ For more detailed information, please refer to the [CX-400 Series User's Manual](#).

12 SPECIFICATIONS

Thru-beam and retroreflective types

Item	Thru-beam			Retroreflective	
	Standard	Long sensing range	Ultra long sensing range	With polarizing filter*1	Long sensing range
NPN output	CX-411*2	CX-412*2	CX-413*2	CX-491*2	CX-493*2
PNP output	CX-411-P*2	CX-412-P*2	CX-413-P*2	CX-491-P*2	CX-493-P*2
Sensing range	10m	15m	30m	3m*3	5m*3
Object to be sensed	∅ 12mm or more opaque object			∅ 50mm or more opaque, translucent or specular object*3	∅ 50mm or more opaque or translucent object*3
Repeatability (perpendicular to sensing axis)	0.5mm or less				
Supply voltage	12 to 24V DC ±10% Ripple P-P 10% or less				
Current consumption	Emitter: 15mA or less Receiver: 10mA or less	Emitter: 20mA or less Receiver: 10mA or less	Emitter: 25mA or less Receiver: 10mA or less	13mA or less	10mA or less
Output	NPN or PNP output type				
	<ul style="list-style-type: none"> • NPN or PNP open-collector transistor • NPN: Maximum sink current: 100mA; PNP: Maximum source current: 100mA • Applied voltage: 30V DC or less (NPN: between output and 0V; PNP: between output and +V) • Residual voltage: NPN: 2V or less (at 100mA sink current), 1V or less (at 16mA sink current) PNP: 2V or less (at 100mA source current), 1V or less (at 16mA source current) 				
	Output operation	Light-ON or Dark-ON			
Short-circuit protection	Incorporated				
Response time	1ms or less		2ms or less	1ms or less	
Automatic interference prevention function	By mounting interference prevention filters*4, two sets of the sensors can be mounted close together.	—		Incorporated	
Protection	IP67 (IEC)				
Ambient temperature	-25 to +55°C (No dew condensation or icing allowed), Storage: -30 to +70°C				
Ambient humidity	35 to 85% RH, Storage: 35 to 85% RH				
Emitting element	Red LED	Infrared LED		Red LED	
Material	Enclosure: PBT, Lens: Acrylic, Indicator cover: Acrylic				
Cable	0.2mm ² 3-core (thru-beam type sensor emitter: 2-core) cabtyre cable, 2m long				
Weight	Net	Emitter: approx. 45g ; Receiver: approx. 50g		Approx. 50g	
	Gross	Approx. 100g		Approx. 80g	
Accessory*5	—			RF-230 (Reflector): 1 pc.	

*1The retroreflective type sensor with polarizing filters may not stably detect specular or glossy objects through transparent film since light is polarized by the transparent film. For details, see page 5, section 8, RETROREFLECTIVE TYPE SENSOR WITH POLARIZING FILTERS.

*2Model nos. with the suffix -J indicate the M12 pigtailed type. The suffix -Z indicates the M8 connector type. Thru-beam model nos. with the suffix "E" shown on the label affixed to the sensor is the emitter; "D" is the receiver. The retroreflective type sensor model no. with the suffix "-Y" comes without the **RF-230** reflector.

*3The sensing range and the sensing object for the retroreflective type sensor is specified for the **RF-230** reflector. For more detailed information, please refer to the [CX-400 Series User's Manual](#). After installation, be sure to check operation under actual conditions.

*4 For details, see page 5, section 10, INTERFERENCE PREVENTION FILTERS.

*5The RF-230 reflector is included with the product. Other reflectors and reflective tape are available for purchase. For more detailed information, please refer to the [CX-400 Series User's Manual](#).

Diffuse reflective types

Item					Narrow view
	NPN output	CX-424^{*1}	CX-421^{*1}	CX-422^{*1}	CX-423^{*1}
	PNP output	CX-424-P^{*1}	CX-421-P^{*1}	CX-422-P^{*1}	CX-423-P^{*1}
Sensing range		100mm ^{*2}	300mm ^{*2}	800mm ^{*2}	70 to 300mm ^{*2}
Object to be sensed		Opaque, translucent or transparent object ^{*3}			Opaque, translucent or transparent object ^{*3 *4}
Hysteresis		15% or less of operation distance ^{*2}			
Repeatability (perpendicular to sensing axis)		1mm or less			0.5mm or less
Supply voltage		12 to 24V DC ±10% Ripple P-P 10% or less			
Current consumption		13mA or less			15mA or less
Output		<p align="center">NPN or PNP output type</p> <ul style="list-style-type: none"> • NPN or PNP open-collector transistor • NPN: Maximum sink current: 100mA; PNP: Maximum source current: 100mA • Applied voltage: 30V DC or less (NPN: between output and 0V; PNP: between output and +V) • Residual voltage: NPN: 2V or less (at 100mA sink current), 1V or less (at 16mA sink current) PNP: 2V or less (at 100mA source current), 1V or less (at 16mA source current) 			
	Output operation	Light-ON or Dark-ON			
	Short-circuit protection	Incorporated			
Response time		1ms or less			
Automatic interference prevention function		Incorporated			
Protection		IP67 (IEC)			
Ambient temperature		-25 to +55°C (No dew condensation or icing allowed), Storage: -30 to +70°C			
Ambient humidity		35 to 85% RH, Storage: 35 to 85% RH			
Emitting element		Infrared LED			Red LED
Material		Enclosure: PBT, Lens: Acrylic, Indicator cover: Acrylic			
Cable		0.2mm ² 3-core (thru-beam type sensor emitter: 2-core) cabtyre cable, 2m long			
Weight	Net	Approx. 50g			
	Gross	Approx. 60g			

^{*1}Model nos. with the suffix -J indicate the M12 pigtailed type. The suffix -Z indicates the M8 connector type. Thru-beam model nos. with the suffix "E" shown on the label affixed to the sensor is the emitter; "D" is the receiver. The retroreflective type sensor model no. with the suffix "-Y" comes without the **RF-230** reflector.

^{*2}The sensing range is specified for white non-glossy paper (200 × 200mm) as the object being sensed.

^{*3}Sensing may become unstable due to the installation condition or the sensing object. After installation, be sure to check operation with the actual sensing object.

^{*4}The minimum size sensing object is Ø0.5mm copper wire

Retroreflective types for sensing transparent objects

Item		Short sensing range	Standard sensing range	Long sensing range
	NPN output	CX-481* ¹	CX-483* ¹	CX-482* ¹
	PNP output	CX-481-P* ¹	CX-483-P* ¹	CX-482-P* ¹
Sensing range		50 to 500mm* ²	50 to 1000mm* ²	0.1 to 2m* ²
Installation range for the reflector		100 to 500mm* ²	100 to 1000mm* ²	0.8 to 2m* ²
Object to be sensed		∅ 50mm or more for opaque, translucent or transparent object* ²		
Repeatability (perpendicular to sensing axis)		0.5mm or less		
Supply voltage		12 to 24V DC ±10% Ripple P-P 10% or less		
Current consumption		10mA or less		
Output	NPN or PNP output type			
	<ul style="list-style-type: none"> • NPN or PNP open-collector transistor • NPN: Maximum sink current: 100mA; PNP: Maximum source current: 100mA • Applied voltage: 30V DC or less (NPN: between output and 0V; PNP: between output and +V) • Residual voltage: NPN: 2V or less (at 100mA sink current), 1V or less (at 16mA sink current) PNP: 2V or less (at 100mA source current), 1V or less (at 16mA source current) 			
	Output operation	Light-ON or Dark-ON		
	Short-circuit protection	Incorporated		
Response time		1ms or less		
Automatic interference prevention function		Incorporated		
Protection		IP67 (IEC)		
Ambient temperature		-25 to +55°C (No dew condensation or icing allowed), Storage: -30 to +70°C		
Ambient humidity		35 to 85% RH, Storage: 35 to 85% RH		
Emitting element		Infrared LED		
Material		Enclosure: PBT, Lens: Polycarbonate, Indicator cover: Polycarbonate		
Cable		0.2mm ² 3-core (thru-beam type sensor emitter: 2-core) cabtyre cable, 2m long		
Weight	Net	Approx. 50g		
	Gross	Approx. 80g		
Accessory* ³		RF-230 (Reflector): 1 pc.		

*¹Model nos. with the suffix -J indicate the M12 pigtailed type. The suffix -Z indicates the M8 connector type. Thru-beam model nos. with the suffix "E" shown on the label affixed to the sensor is the emitter; "D" is the receiver. The retroreflective type sensor model no. with the suffix "-Y" comes without the **RF-230** reflector.

*²The sensing range and the sensing object for the retroreflective type sensor is specified for the **RF-230** reflector. For more detailed information, please refer to the [CX-400 Series User's Manual](#). After installation, be sure to check operation under actual conditions.

*³The RF-230 reflector is included with the product. Other reflectors and reflective tape are available for purchase. For more detailed information, please refer to the [CX-400 Series User's Manual](#).

Basic types

Item	Thru-beam				Retroreflective ^{*1}		
	Light-ON	Dark-ON	Light-ON	Dark-ON	Light-ON	Dark-ON	
	NPN output	CX-411A-C05	CX-411B-C05	CX-412A-C05	CX-412B-C05	CX-491A-C05-Y	CX-491B-C05-Y
PNP output	CX-411A-P-C05	CX-411B-P-C05	CX-412A-P-C05	CX-412B-P-C05	CX-491A-P-C05-Y	CX-491B-P-C05-Y	
Sensing range	10m		15m		3m ^{*2}		
Object to be sensed	∅ 12mm or more opaque object				∅ 50mm or more opaque, translucent or specular object ^{*2}		
Repeatability (perpendicular to sensing axis)	0.5mm or less						
Supply voltage	12 to 24V DC ±10% Ripple P-P 10% or less						
Current consumption	Emitter: 15mA or less Receiver: 10mA or less		Emitter: 20mA or less Receiver: 10mA or less		13mA or less		
Output	<p align="center">NPN or PNP output type</p> <ul style="list-style-type: none"> • NPN or PNP open-collector transistor • NPN: Maximum sink current: 100mA; PNP: Maximum source current: 100mA • Applied voltage: 30V DC or less (NPN: between output and 0V; PNP: between output and +V) • Residual voltage: NPN: 2V or less (at 100mA sink current), 1V or less (at 16mA sink current) PNP: 2V or less (at 100mA source current), 1V or less (at 16mA source current) 						
	Short-circuit protection	Incorporated					
Response time	1ms or less						
Automatic interference prevention function	By mounting interference prevention filters, two sets of the sensors can be mounted close together. For details, see page 5, section 10, INTERFERENCE PREVENTION FILTERS.				Incorporated		
Protection	IP67 (IEC)						
Ambient temperature	-25 to +55°C (No dew condensation or icing allowed), Storage: -30 to +70°C						
Ambient humidity	35 to 85% RH, Storage: 35 to 85% RH						
Emitting element	Red LED		Infrared LED		Red LED		
Material	Enclosure: PBT, Lens: Acrylic, Indicator cover: Acrylic						
Cable	0.2mm ² 3-core (thru-beam type sensor emitter: 2-core) cabtyre cable, 2m long						
Weight	Net	Emitter: approx. 20g ; Receiver: approx. 20g				Approx. 20g	
	Gross	Approx. 50g				Approx. 30g	

^{*1}The retroreflective type sensor with polarizing filters may not stably detect specular or glossy objects through transparent film since light is polarized by the transparent film. For details, see page 5, section 8, RETROREFLECTIVE TYPE SENSOR WITH POLARIZING FILTERS.

^{*2}The sensing range and the sensing object for the retroreflective type sensor is specified for the **RF-230** reflector. For more detailed information, please refer to the [CX-400 Series User's Manual](#). After installation, be sure to check operation under actual conditions.