

Surface Mount Dual NPN Transistor

2N5794U (TX, TXV)



Features:

- Ceramic 6 pin surface mount package
- Small package to minimize circuit board area
- Hermetically sealed
- Electrical performance similar to dual 2N2222
- Processed per MIL-PRF-19500/495

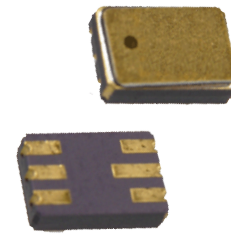

Description:

The 2N5794U (TX, TXV) are hermetically sealed, ceramic surface mount devices, consisting of two individual silicon NPN transistors. The six pin ceramic package is ideal for designs where board space and device weight are important design considerations.

Typical screening and lot acceptance tests are per MIL-PRF-19500/495. The burn-in condition is $V_{CB} = 30\text{ V}$, $P_D = 300\text{ mW}$ each transistor, $T_A = 25^\circ\text{C}$. Refer to MIL-PRF-19500/495 for complete requirements.

When ordering parts without processing, do not use the TX or TXV suffix.

Applications:

- General switching
- Amplification
- Signal processing
- Radio transmission
- Logic gates

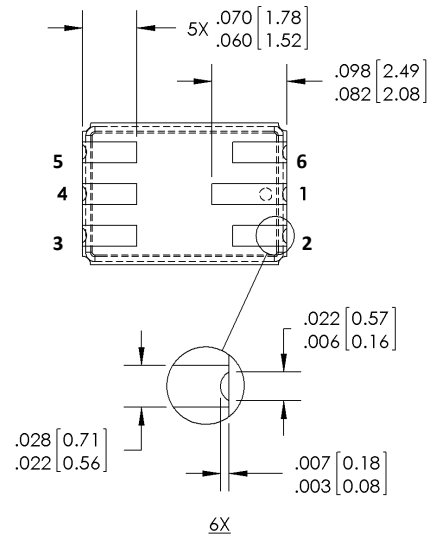
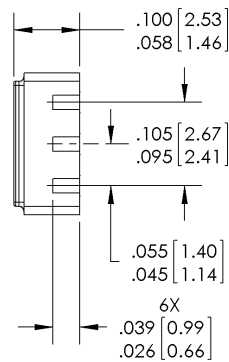
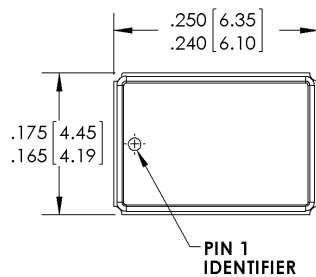

DIMENSIONS ARE IN INCHES [MM]

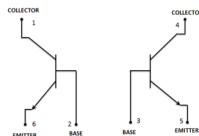

Pin #	LED	Pin #	Transistor
3	Base	2	Base
4	Collector	1	Collector
5	Emitter	6	Emitter

General Note

TT Electronics reserves the right to make changes in product specification without notice or liability. All information is subject to TT Electronics' own data and is considered accurate at time of going to print.

TT Electronics | OPTEK Technology
1645 Wallace Drive, Carrollton, TX 75006 | Ph: +1 972 323 2200
www.ttelectronics.com | sensors@ttelectronics.com

Surface Mount Dual NPN Transistor

2N5794U (TX, TXV)



Electrical Specifications

Absolute Maximum Ratings ($T_A = 25^\circ\text{C}$ unless otherwise noted)

Collector-Emitter Voltage	45 V
Collector-Base Voltage	75 V
Emitter-Base Voltage	6 V
Collector Current-Continuous	600 mA
Operating Junction Temperature (T_J)	-65° C to +200° C
Storage Junction Temperature (T_{stg})	-65° C to +200° C
Power Dissipation @ $T_A = 25^\circ\text{C}$	0.5 W
Power Dissipation @ $T_c = 25^\circ\text{C}$	0.6 W ⁽¹⁾
Soldering Temperature (vapor phase reflow for 30 seconds)	215° C
Soldering Temperature (heated collet for 5 seconds)	260° C

Electrical Characteristics ($T_A = 25^\circ\text{C}$ unless otherwise noted)

SYMBOL	PARAMETER	MIN	MAX	UNITS	TEST CONDITIONS
OFF CHARACTERISTICS					
$V_{(BR)CEO}$	Collector-Emitter Breakdown Voltage	40	-	V	$I_C = 10\text{ mA}^{(1)}$
I_{CBO1}	Collector-Base Cutoff Current		10	μA	$V_{CB} = 75\text{ V}$
I_{CBO2}	Collector-Base Cutoff Current		10	nA	$V_{CB} = 50\text{ V}$
I_{CBO3}	Collector-Base Cutoff Current		10	μA	$V_{BC} = 50\text{ V}, T_A = 150^\circ\text{C}$
I_{EBO1}	Emitter-Base Breakdown Voltage		10	V	$V_{EB} = 6\text{ V}$
I_{EBO2}	Emitter-Base Cutoff Current		10	nA	$V_{EB} = 4\text{ V}$
h_{FE1}	Forward-Current Transfer Ratio	35		-	$V_{CE} = 10\text{ V}, I_C = 0.1\text{ mA}$
h_{FE2}		50		-	$V_{CE} = 10\text{ V}, I_C = 1.0\text{ mA}$
h_{FE3}		75		-	$V_{CE} = 10\text{ V}, I_C = 10\text{ mA}^{(1)}$
h_{FE4}		100	300	-	$V_{CE} = 10\text{ V}, I_C = 150\text{ mA}^{(1)}$
h_{FE5}		40		-	$V_{CE} = 10\text{ V}, I_C = 300\text{ mA}^{(1)}$
h_{FE6}		50		-	$V_{CE} = 1.0\text{ V}, I_C = 150\text{ mA}^{(1)}$
h_{FE7}		40		-	$V_{CE} = 10\text{ V}, I_C = 150\text{ mA}, T_A = -55^\circ\text{C}^{(1)}$

General Note

TT Electronics reserves the right to make changes in product specification without notice or liability. All information is subject to TT Electronics' own data and is considered accurate at time of going to print.

TT Electronics | OPTEK Technology
1645 Wallace Drive, Carrollton, TX 75006 | Ph: +1 972 323 2200
www.ttelectronics.com | sensors@ttelectronics.com

Surface Mount Dual NPN Transistor

2N5794U (TX, TXV)



Electrical Specifications

Electrical Characteristics ($T_A = 25^\circ\text{C}$ unless otherwise noted)

SYMBOL	PARAMETER	MIN	MAX	UNITS	TEST CONDITIONS
Off Characteristics continued					
$V_{CE(SAT)1}$	Collector-Emitter Saturation Voltage		0.3	V	$I_C = 150\text{ mA}, I_B = 15\text{ mA}^{(1)}$
$V_{CE(SAT)2}$	Collector-Emitter Saturation Voltage		0.9	V	$I_C = 300\text{ mA}, I_B = 30\text{ mA}^{(1)}$
$V_{BE(SAT)1}$	Base-Emitter Saturation Voltage	0.6	1.2	V	$I_C = 150\text{ mA}, I_B = 15\text{ mA}^{(1)}$
$V_{BE(SAT)2}$	Base-Emitter Saturation Voltage		1.8	V	$I_C = 300\text{ mA}, I_B = 30\text{ mA}^{(1)}$
$ h_{fe} $	Magnitude of Small-Signal Short-Circuit Forward Current Transfer Ratio	2	10		$V_{CE} = 20\text{ V}, I_C = 20\text{ mA}, f = 100\text{ MHz}$
C_{obo}	Open Circuit Output Capacitance		8	pF	$V_{CB} = 10\text{ V}, I_E = 0, 100\text{ kHz} \leq f \leq 1\text{ MHz}$
C_{ibo}	Input Capacitance (output open)		33	pF	$V_{EB} = 0.5\text{ V}, I_C = 0, 100\text{ kHz} \leq f \leq 1\text{ MHz}$
t_{on}	Turn-on Time		45	ns	$V_{CC} = 30\text{ V}, I_C = 150\text{ mA}, I_{B1} = 15\text{ mA}, PW = 200\text{ ns}$
t_{off}	Turn-off Time		310	ns	$V_{CC} = 30\text{ V}, I_C = 150\text{ mA}, I_{B1} = I_{B2} = 15\text{ mA}, PW = 10\text{ }\mu\text{s}$

Standard Packaging:

Waffle Pack

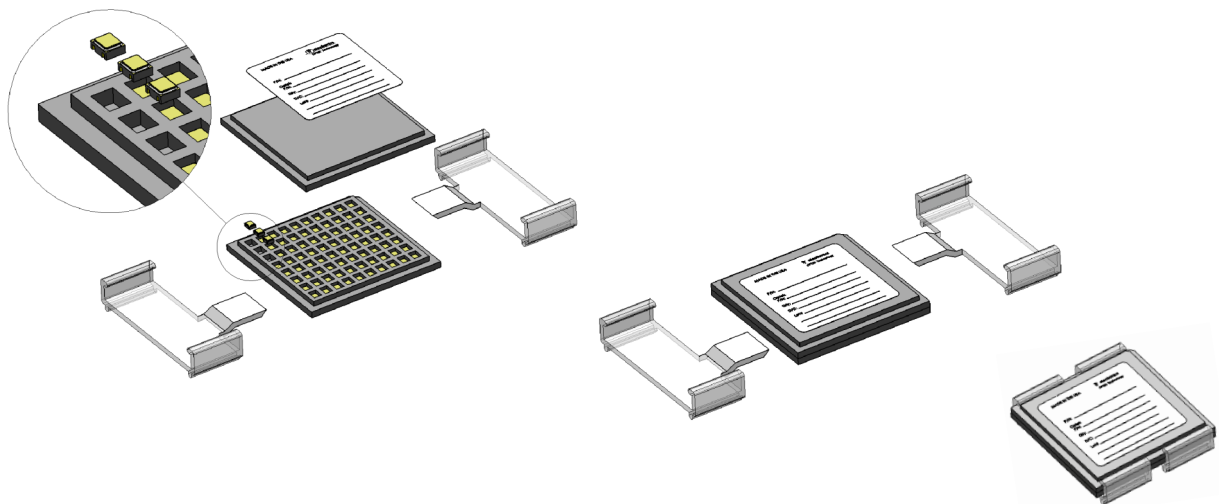

Note:

1. Pulsed Test: Pulse Width = $300\text{ }\mu\text{s} \pm 50$, 1-2 % Duty Cycle

General Note

TT Electronics reserves the right to make changes in product specification without notice or liability. All information is subject to TT Electronics' own data and is considered accurate at time of going to print.

TT Electronics | OPTEK Technology
 1645 Wallace Drive, Carrollton, TX 75006 | Ph: +1 972 323 2200
www.ttelectronics.com | sensors@ttelectronics.com