

Product Data Sheet

9244014896

VVY0108XQHCS

4656 TZ

ebmpapst

The engineer's choice



4656 TZ

INDEX

1 General 3

2 Mechanics 3

2.1 General..... 3

2.2 Connections..... 4

3 Operating Data 5

3.1 Electrical Operating Data 5

3.2 Electrical Features 6

3.3 Aerodynamics 6

3.4 Sound Data..... 7

4 Environment..... 7

4.1 General..... 7

4.2 Climatic Requirements 8

5 Safety..... 8

5.1 Electrical Safety 8

5.2 Approval Tests..... 8

6 Reliability..... 8

6.1 General..... 9

1 General

Fan type	Fan without chassis
Rotating direction looking at rotor	Clockwise
Airflow direction	Air outlet over traverse
Bearing system	Ball bearing
Mounting position - shaft	Any
Balancing grade	2,5

2 Mechanics

2.1 General

Width	0,0 mm	
Height	0,0 mm	
Depth	37,0 mm	
Diameter	108,0 mm	
Mass	0,420 kg	
Housing material		
Impeller material	Metal	

2.2 Connections

Electrical connection	Wires	
Lead wire length	L = 375,0 mm	
Tolerance	+ - 10,0 mm	
Tube length	See drawing	
Tolerance		
Wire size (AWG)	20	
Insulation diameter	1,3 mm	
Plug	See drawing	
Contact	See drawing	

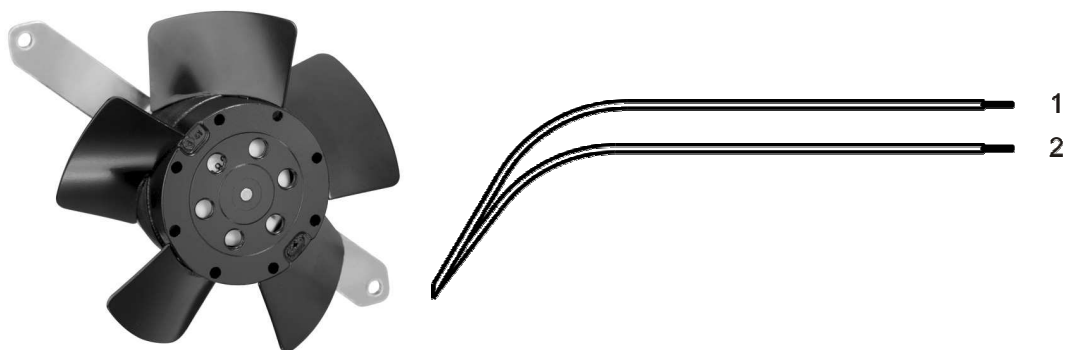

	Color	Operation
1	black	L
2	black	N

3 Operating Data

3.1 Electrical Operating Data

For checking purposes the electrical data can be specified without an intake nozzle / aperture plate as well. For this the data have to be defined by the appropriate quality assurance.

Electrical Operating Data with Intake Nozzle (for testing purposes)

Measurement conditions: Normal air density = 1,2 kg/m³; Temperature 23°C +/- 3°C; Motor axis horizontal; warm-up time before measuring 5 minutes (unless otherwise specified).
In the intake and outlet area should not be any solid obstruction within 0,5 m.

Measurement setup:	Measured with an aperture plate
Aperture plate diameter:	109 mm
Distance between mounting traverse and aperture plate:	17 mm

$\Delta p = 0$: corresp. to free air flow (see chapter aerodynamics)

I: corresp. to RMS line current

Features	Condition	Symbol	Values	
Frequency	$\Delta p = 0$	f	50 Hz	60 Hz
Nominal voltage	$\Delta p = 0$	U_N	230,0 V	230,0 V
Tolerance			+ 6,0 % - 10,0 %	+ 6,0 % - 10,0 %
Power consumption	$\Delta p = 0$	P	19,0 W	18,0 W
Tolerance			+/- 10,0 %	+/- 10,0 %
Speed	$\Delta p = 0$	n	2.600 1/min	2.950 1/min
Tolerance			+/- 3,0 %	+/- 3,0 %

3.2 Electrical Features

Locked rotor protection	Impedance
Locked rotor current at	

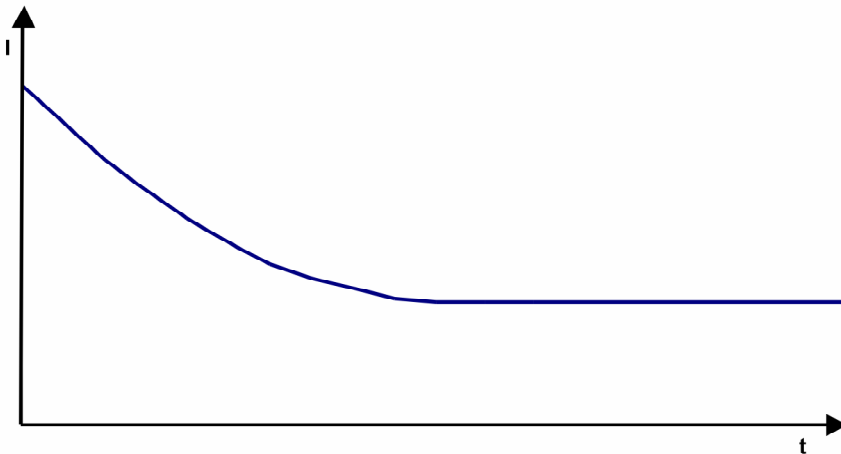

3.3 Aerodynamics

Measurement conditions: Measured with a double chamber intake rig acc. to DIN EN ISO 5801. Normal air density = 1,2 kg/m³; Temperature 23°C +/- 3°C; In the intake and outlet area should not be any solid obstruction within 0,5 m. Motor shaft horizontal. The information is only valid under the specified test conditions and may be changed by the installation conditions. If there are deviations from the standard test conditions, the characteristic values must be checked under the installed conditions.

Measurement setup:	Measured with an aperture plate
Aperture plate diameter:	109 mm
Distance between mounting traverse and aperture plate:	17 mm

a.) Operation condition:
 2.600 1/min at free air flow Frequency: 50 Hz

Max. free-air flow ($\Delta p = 0 / \dot{V} = \text{max.}$)	126,0 m ³ /h
Max. static pressure ($\Delta p = \text{max.} / \dot{V} = 0$)	70 Pa

b.) Operation condition:
 2.950 1/min at free air flow Frequency: 60 Hz

Max. free-air flow ($\Delta p = 0 / \dot{V} = \text{max.}$)	142,0 m ³ /h
Max. static pressure ($\Delta p = \text{max.} / \dot{V} = 0$)	70 Pa

3.4 Sound Data

Measurement conditions: Sound pressure level: 1 meter distance between microphone and the air intake.
 Sound power level: Acc. to DIN 45635 part 38 (ISO 10302) Sound power level: Acc. to DIN 45635 part 38 (ISO 10302)
 Measured in a semianchoic chamber with a background noise level of $L_p(A) < 5 \text{ dB(A)}$
 For further measurement conditions see chapter aerodynamics.

a.) Operation condition:

2.600 1/min at free air flow

Frequency: 50 Hz

Optimal operating point		
Sound power level at the optimal operating point		
Sound pressure level at free air flow, measured in rubber bands	37,0 dB(A)	

b.) Operation condition:

2.950 1/min at free air flow

Frequency: 60 Hz

Optimal operating point		
Sound power level at the optimal operating point		
Sound pressure level at free air flow, measured in rubber bands	42,0 dB(A)	

4 Environment

4.1 General

Min. permitted ambient temperature TU min.	-40 °C / 50 Hz -40 °C / 60 Hz	
Max. permitted ambient temperature TU max.	65 °C / 50 Hz 75 °C / 60 Hz	
Min. permitted storage temperature TL min.	-40 °C	
Max. permitted storage temperature TL max.	80 °C	

4.2 Climatic Requirements

Humidity requirements	humid heat, constant; according to DIN EN 60068-2-78, 14 days	
Water exposure	None	
Dust requirements	None	
Salt fog requirements	None	

Permitted application area:

The product is intended for use in sheltered rooms with controlled temperature and controlled humidity. Directly exposure to water must be avoided.

Pollution degree 1 (according DIN EN 60664-1)

There is either no pollution or it occurs only dry, non-conductive pollution. The pollution has no negative impact.

5 Safety

5.1 Electrical Safety

Dielectric strength DIN EN 60950 (VDE 0805) and DIN EN 60335 (VDE 0700) A.) Type test Measuring conditions: After 48h of storage at 95% R.H. and 25°C. No arcing or breakdown is allowed! All connections together to ground. B.) Routine test Measuring conditions: At indoor climate. No arcing or breakdown is allowed! All connections together to ground.	1500 VAC / 1 Min. 1500 VAC / 1 Sec.
Isolation resistance Measuring conditions: After 48h of storage at 95% R.H. and 25°C measured with U=500 VDC for 1 min.	RI > 50 MOhm
Clearance / creepage distance	2,0 mm / 1,8 mm
Protection class	I

5.2 Approval Tests

CE	EC Declaration of Conformity	Yes
EAC	Eurasian Conformity	Yes
UL	Underwriters Laboratories	Yes / UL507, Electric Fans E38324
VDE	Association for Electrical, Electronic and Information Technologies	Yes / Approval acc. to EN 60950 (VDE 0805) - Information technology equipment
CSA	Canadian Standards Association	Yes / C22.2 No. 113 Fans and Ventilators
CCC	China Compulsory Certification	Yes / GB 12350 Safety Requirements for small Power Motors

The approval tests are observed to:

U approval max.: 230 V / f: 60 Hz @ TU approval max.: 75 °C

6 Reliability

6.1 General

Life expectancy L10 at TU = 40 °C	37.500 h / 50 Hz 40.000 h / 60 Hz	
Life expectancy L10 at TU max.	20.000 h / 50 Hz 17.500 h / 60 Hz	

Copying of this document, and giving it to others, and the use or communication of its contents, in any form, are prohibited without express written permission of the copyright holder. All rights are reserved. In the event of the part or a part of a part or the registration of a trademark, model, or design.

SCHUTZVERMERK: nach DIN EN ISO 9001:2015
Refer to protection notice DIN ISO 9001

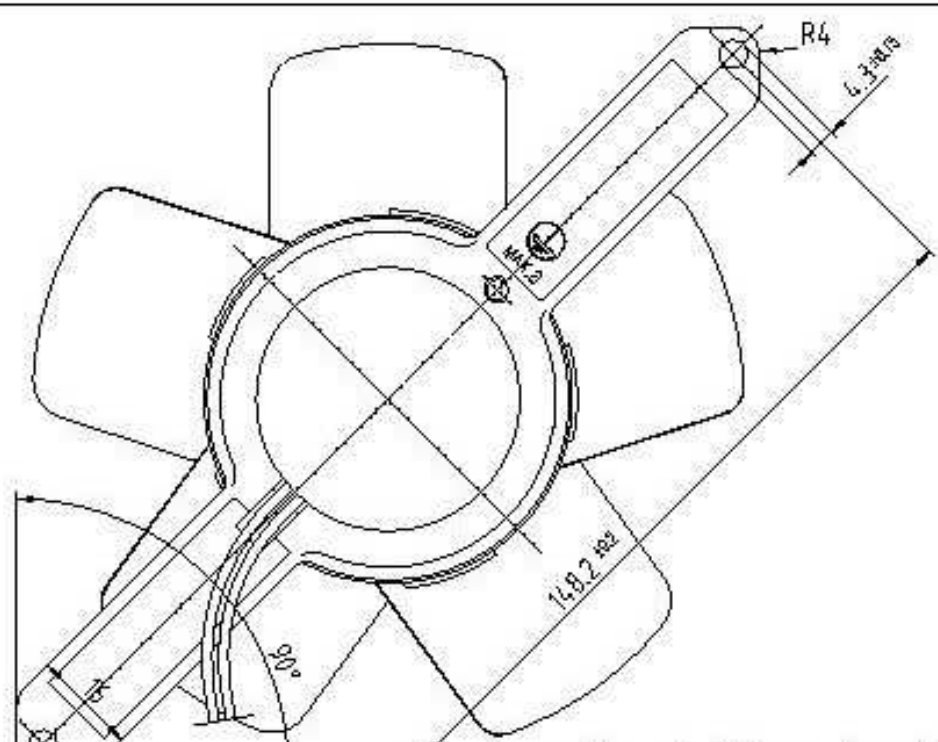

Anzahl und Länge der Litzen
siehe Spezifikation

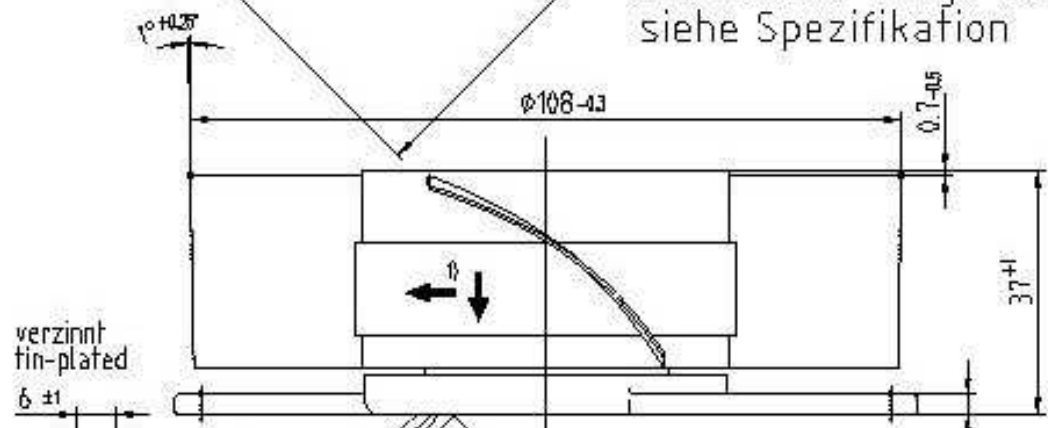

length and number of wires
see design specification

- 1) in weiß aufgestempelt
Axialspiel bei
- Kugellagerung (K): 0 (mit Federausgleich)
- Gleitlagerung (G): 0.1 - 0.6

- 1| white be stamped
axial clearance by
- ball bearing (K): 0 |with spring compensation)
- sleeve bearing (G): 0.1 - 0.6

		ebmpapst		Werkstoff/Material:		Volumen/Volume (mm ³):	
SIP-Schema/Sheet	Fert.-Nr./Clamp-No.	Art/CAD-Schema-Version	CO ₂ -Angebotung/ CO ₂ -Environment			Gewicht/Mass (g):	
		Lieferfirma Name/Name		Artikel/Title			
		Bezeichnung/Description					
		Typ/Type					
Allgemeintoleranzen/Gen. tolerances				Zchg.-Nr./Drawing-No.		Ersf.Zchg./Replaces	
				Dokumenttyp/Type of Document	Feldbezeichnung/Field/Field	Ind./Index	Format/Size
		ebm-papst St. Georgen GmbH & Co. KG					

Mouser Electronics

Authorized Distributor

Click to View Pricing, Inventory, Delivery & Lifecycle Information:

[ebm-papst:](#)

[4656TZ](#)