

Features

- For Switching and AF Amplifier Applications
- Halogen Free Available Upon Request By Adding Suffix "-HF"
- Moisture Sensitivity Level 1
- Epoxy Meets UL 94 V-0 Flammability Rating
- Lead Free Finish/RoHS Compliant ("P" Suffix Designates RoHS Compliant. See Ordering Information)

Maximum Ratings

- Operating Junction Temperature Range: -55°C to +150°C
- Storage Temperature Range: -55°C to +150°C
- Thermal Resistance: 320°C/W Junction to Solder-point (Note1)
- Thermal Resistance: 403°C/W Junction to Ambient (Note1)

Parameter	Symbol	Rating	Unit
Collector-Base Voltage	V_{CBO}	-50	V
Collector-Emitter Voltage	V_{CEO}	-45	V
Emitter-Base Voltage	V_{EBO}	-5	V
Collector Current	I_C	-100	mA
Peak Collector Current	I_{CM}	-200	mA
Peak Emitter Current	I_{EM}	-200	mA
Power Dissipation $T_S=50^\circ\text{C}$ (Note1)	P_D	310	mW

Note: 1. Package Mounted 1.0*1.0mm Pad Layout 1oz Copper That is On a Single-sided FR4 PCB.

Part Number	BC857A	BC857B	BC857C
Marking	3E	3F	3G

Internal Structure

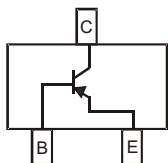

PNP Small Signal Transistor

SOT-23

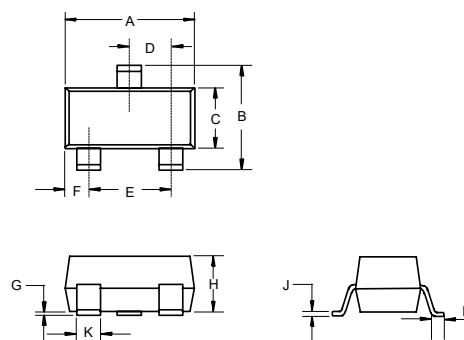

DIMENSIONS

DIM	INCHES		MM		NOTE
	MIN	MAX	MIN	MAX	
A	0.110	0.120	2.80	3.04	
B	0.083	0.104	2.10	2.64	
C	0.047	0.055	1.20	1.40	
D	0.034	0.041	0.85	1.05	
E	0.067	0.083	1.70	2.10	
F	0.018	0.024	0.45	0.60	
G	0.0004	0.006	0.01	0.15	
H	0.035	0.043	0.90	1.10	
J	0.003	0.007	0.08	0.18	
K	0.014	0.020	0.35	0.51	
L	0.007	0.020	0.20	0.50	

Suggested Solder Pad Layout

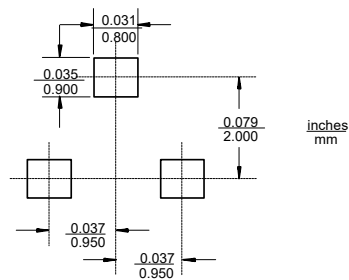

Electrical Characteristics @ 25°C Unless Otherwise Specified

Parameter		Symbol	Min	Typ	Max	Units	Conditions
Collector-Base Breakdown Voltage ^(Note2)		$V_{(BR)CBO}$	-50			V	$I_C=-10\mu A, I_E=0$
Collector-Emitter Breakdown Voltage ^(Note2)		$V_{(BR)CEO}$	-45			V	$I_C=-10mA, I_B=0$
Emitter-Base Breakdown Voltage ^(Note2)		$V_{(BR)EBO}$	-5			V	$I_E=-1\mu A, I_C=0$
Collector-Cutoff Current ^(Note2)		I_{CES}			-15	nA	$V_{CE}=-50V$
		I_{CBO}			-15	nA	$V_{CB}=-30V$
					-4	μA	$V_{CB}=-30V, T_A=150^\circ C$
DC Current Gain ^(Note2)	BC857 A	h_{FE}	125	180	250		$V_{CE}=-5Vdc, I_C=-2mA$
	BC857 B		220	290	475		
	BC857 C		420	520	800		
Small Signal Current Gain	BC857 A	h_{fe}		200			$V_{CE}=-5V$ $I_C=-2mA$ $f=1KHz$
	BC857 B			330			
	BC857 C			600			
Input Impedance	BC857 A	h_{ie}		2.7		K Ω	
	BC857 B			4.5			
	BC857 C			8.7			
Output Admittance	BC857 A	h_{oe}		18		μS	
	BC857 B			30			
	BC857 C			60			
Reverse Voltage Transfer Ratio	BC857 A	h_{re}		1.5×10^{-4}			
	BC857 B			2×10^{-4}			
	BC857 C			3×10^{-4}			
Collector-Emitter Saturation Voltage ^(Note2)		$V_{CE(sat)}$		-75	-300	mV	$I_C=-10mA, I_B=-0.5mA$
					-250	-650	mV
Base-Emitter Saturation Voltage ^(Note2)		$V_{BE(sat)}$		-700		mV	$I_C=-10mA, I_B=-0.5mA$
					-850		mV
Base-Emitter Voltage ^(Note2)		V_{BE}	-600	-650	-750	mV	$V_{CE}=-5V, I_C=-2mA$
					-820		mV
Current Gain-Bandwidth Product		f_T	100	200		MHz	$V_{CE}=-5V, I_C=-10mA, f=100MHz$
Collector-Base Capacitance		C_{CBO}		3		pF	$V_{CB}=-10V, f=1MHz$
Noise Figure		NF		2	10	dB	$V_{CE}=-5V, I_C=-200\mu A$ $R_S=2K\Omega, f=1KHz, \Delta f=200Hz$

Note: 2. Short Duration Pulse Test to Minimize Self-heating Effect.

Curve Characteristics

Fig. 1 - Static Characteristics

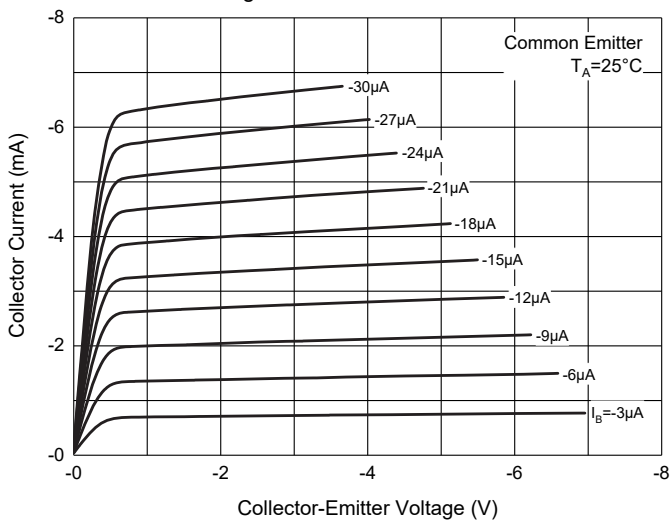

Fig. 2 - DC Current Gain Characteristics

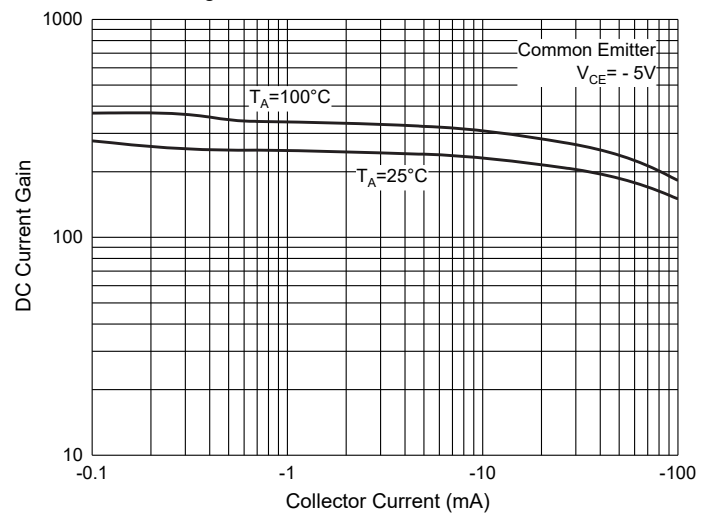

Fig. 3 - Collector-Emitter Saturation Voltage Characteristics

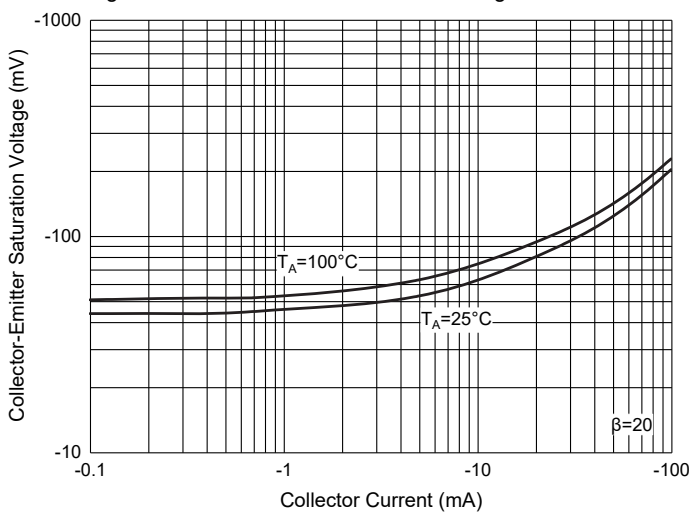

Fig. 4 - Base-Emitter Saturation Voltage Characteristics

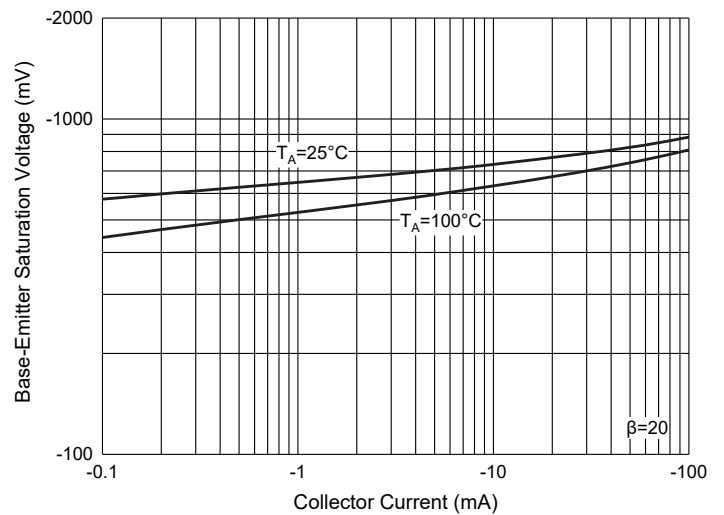

Fig. 5 - Base-Emitter Voltage Characteristics

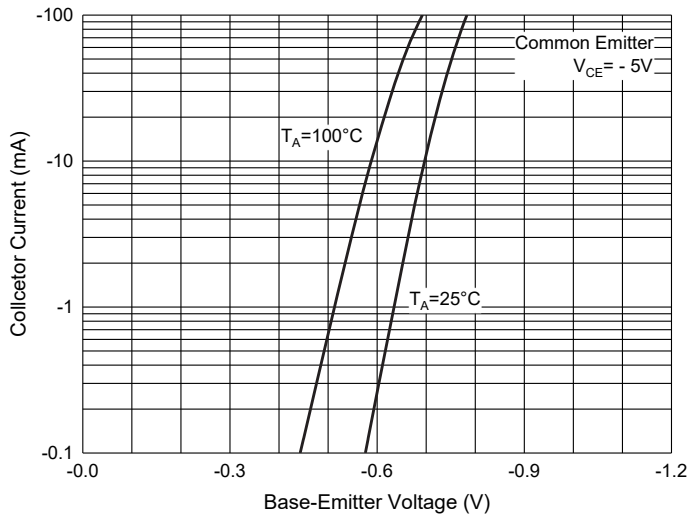
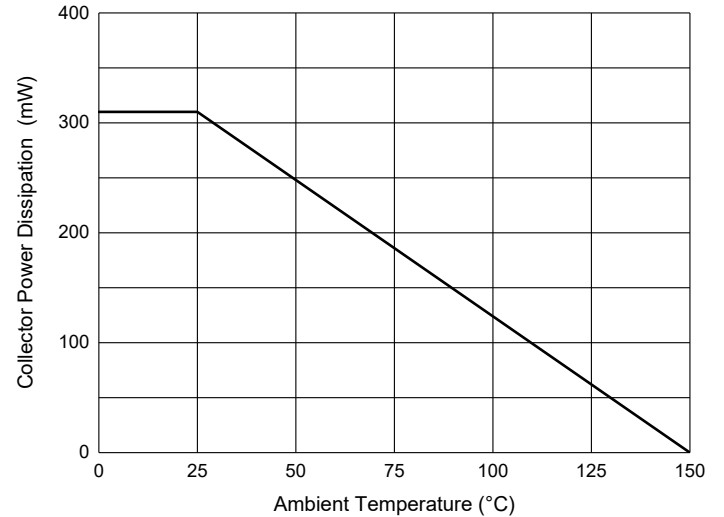

Fig. 6 - Collector Power Derating Curve



Ordering Information

Device	Packing
Part Number-TP	Tape&Reel: 3Kpcs/Reel

Note : Adding "-HF" Suffix For Halogen Free, eg. Part Number-TP-HF

IMPORTANT NOTICE

Micro Commercial Components Corp. reserves the right to make changes without further notice to any product herein to make corrections, modifications , enhancements , improvements , or other changes . **Micro Commercial Components Corp** . does not assume any liability arising out of the application or use of any product described herein; neither does it convey any license under its patent rights ,nor the rights of others . The user of products in such applications shall assume all risks of such use and will agree to hold **Micro Commercial Components Corp** . and all the companies whose products are represented on our website, harmless against all damages.

LIFE SUPPORT

MCC's products are not authorized for use as critical components in life support devices or systems without the express written approval of Micro Commercial Components Corporation.

CUSTOMER AWARENESS

Counterfeiting of semiconductor parts is a growing problem in the industry. Micro Commercial Components (MCC) is taking strong measures to protect ourselves and our customers from the proliferation of counterfeit parts. MCC strongly encourages customers to purchase MCC parts either directly from MCC or from Authorized MCC Distributors who are listed by country on our web page cited below. Products customers buy either from MCC directly or from Authorized MCC Distributors are genuine parts, have full traceability, meet MCC's quality standards for handling and storage. **MCC will not provide any warranty coverage or other assistance for parts bought from Unauthorized Sources.** MCC is committed to combat this global problem and encourage our customers to do their part in stopping this practice by buying direct or from authorized distributors.