



Features:

- Motor: Shaded Pole Induction Motor
- Motor Protection: Impedance Protected
- Bearing Type: Two Ball, Sleeve, or Hydro Dynamic
- Connection: UL 1430 AWG 22, 280mm Wire Leads or Terminal
- Frame Material: Aluminum Alloy
- Impeller Material: Plastic UL94V-0
- Operating Temp:
 - Two Ball: -10°C~70°C
 - Sleeve: -10°C~60°C
 - Hydro Dynamic: -10°C~70°C
- Life Expectancy:
 - Two Ball: 50,000 Hours
 - Sleeve: 30,000 Hours
 - Hydro Dynamic: 50,000 Hours



Fan-S Division



Model No.	Volt.	Freq.	Current	Power	Rated Speed	Maximum AirFlow		Maximum Static Pressure		Noise Level	Weight
	(VAC)	(Hz)	(A)	(W)	(rpm)	(CMM)	(CFM)	(InAq)	(mmAq)	(dB/A)	(g)
FAA1-12038N * H ** 31	115	50/60	0.23/0.18	17.00/14.00	2700/3000	2.348/2.674	83.0/94.5	0.330/0.350	7.620/8.890	42.2/44.5	550
FAA1-12038Q * H ** 31	230	50/60	0.12/0.10	17.00/14.00	2700/3000	2.348/2.674	83.0/94.5	0.330/0.350	7.620/8.890	42.2/44.5	550
FAA1-12038N * M ** 31	115	50/60	0.16/0.14	18.40/16.10	2600/2800	2.306/2.462	81.5/87.0	0.244/0.210	6.197/5.334	41.0/43.0	550
FAA1-12038Q * M ** 31	230	50/60	0.08/0.07	18.40/16.10	2600/2800	2.306/2.462	81.5/87.0	0.244/0.210	6.197/5.334	41.0/43.0	550
FAA1-12038N * L ** 31	115	50/60	0.10/0.09	11.50/10.35	2400/2200	2.150/1.924	76.0/68.0	0.180/0.100	4.572/2.540	40.1/37.9	550
FAA1-12038Q * L ** 31	230	50/60	0.05/0.04	11.50/9.20	2400/2200	2.150/1.924	76.0/68.0	0.180/0.100	4.572/2.540	40.1/37.9	550
FAA1-12038N * A ** 31	115	50/60	0.08/0.07	9.20/8.05	2300/1700	1.981/1.514	70.0/53.5	0.130/0.060	3.302/1.524	39.2/30.5	550
FAA1-12038Q * A ** 31	230	50/60	0.04/0.04	9.20/9.20	2300/1700	1.981/1.514	70.0/53.5	0.130/0.060	3.302/1.524	39.2/30.5	550

* Indicates "B" (Ball Bearing), "S" (Sleeve Bearing), or "H" (Hydro Dynamic)

Noise is measured at the distance of one (1) meter from the axis of intake.

** Indicates "W" (Wire Leads) or "T" (Terminal)

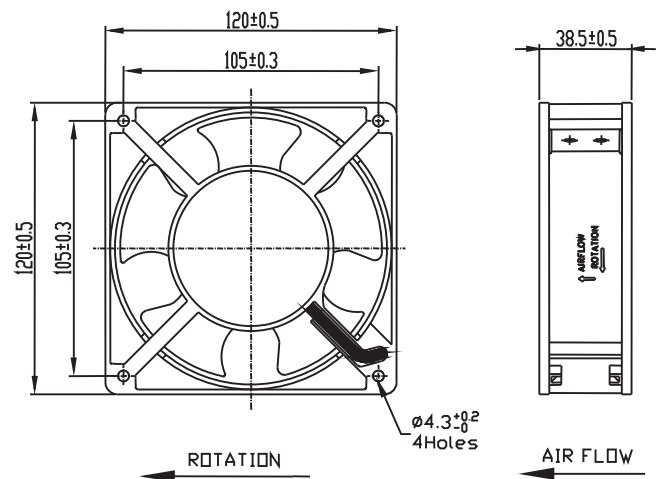

Mouser Electronics

Authorized Distributor

Click to View Pricing, Inventory, Delivery & Lifecycle Information:

Qualtek:

[FAA1-12038NBAT31](#) [FAA1-12038NBAW31](#) [FAA1-12038NBHT31](#) [FAA1-12038NBHW31](#) [FAA1-12038NBLT31](#)
[FAA1-12038NBLW31](#) [FAA1-12038NBMT31](#) [FAA1-12038NBMW31](#) [FAA1-12038NHAT31](#) [FAA1-12038NHAW31](#)
[FAA1-12038NHHT31](#) [FAA1-12038NHHW31](#) [FAA1-12038NHLT31](#) [FAA1-12038NHLW31](#) [FAA1-12038NHMT31](#)
[FAA1-12038NHMW31](#) [FAA1-12038NSAT31](#) [FAA1-12038NSAW31](#) [FAA1-12038NSHT31](#) [FAA1-12038NSHW31](#)
[FAA1-12038NSLT31](#) [FAA1-12038NSLW31](#) [FAA1-12038NSMT31](#) [FAA1-12038NSMW31](#) [FAA1-12038QBAT31](#) [FAA1-](#)
[12038QBAW31](#) [FAA1-12038QBHT31](#) [FAA1-12038QBHW31](#) [FAA1-12038QBLT31](#) [FAA1-12038QBLW31](#) [FAA1-](#)
[12038QBMT31](#) [FAA1-12038QBMW31](#) [FAA1-12038QHAT31](#) [FAA1-12038QHAW31](#) [FAA1-12038QHHT31](#) [FAA1-](#)
[12038QHHW31](#) [FAA1-12038QHLT31](#) [FAA1-12038QHLW31](#) [FAA1-12038QHMT31](#) [FAA1-12038QHMW31](#) [FAA1-](#)
[12038QSAT31](#) [FAA1-12038QSAW31](#) [FAA1-12038QSHT31](#) [FAA1-12038QSHW31](#) [FAA1-12038QSLT31](#) [FAA1-](#)
[12038QSLW31](#) [FAA1-12038QSMT31](#) [FAA1-12038QSMW31](#) [FAA1-12038NBAT31-A](#) [FAA1-12038NBAW31-A](#) [FAA1-](#)
[12038NBHW31-A](#) [FAA1-12038NBLT31-A](#) [FAA1-12038NHAT31-A](#) [FAA1-12038NHAW31-A](#) [FAA1-12038NHHT31-A](#)
[FAA1-12038NHHW31-A](#) [FAA1-12038NHLT31-A](#) [FAA1-12038NHLW31-A](#) [FAA1-12038NHMT31-A](#) [FAA1-](#)
[12038NHMW31-A](#) [FAA1-12038NSAT31-A](#) [FAA1-12038NSAW31-A](#) [FAA1-12038NSHT31-A](#) [FAA1-12038NSHW31-A](#)
[FAA1-12038NSLT31-A](#) [FAA1-12038NSLW31-A](#) [FAA1-12038NSMT31-A](#) [FAA1-12038NSMW31-A](#) [FAA1-](#)
[12038QBAT31-A](#) [FAA1-12038QBAW31-A](#) [FAA1-12038QBHT31-A](#) [FAA1-12038QHAT31-A](#) [FAA1-12038QHAW31-A](#)
[FAA1-12038QHHT31-A](#) [FAA1-12038QHHW31-A](#) [FAA1-12038QHLT31-A](#) [FAA1-12038QHLW31-A](#) [FAA1-](#)
[12038QHMT31-A](#) [FAA1-12038QHMW31-A](#) [FAA1-12038QSAT31-A](#) [FAA1-12038QSAW31-A](#) [FAA1-12038QSHT31-A](#)
[FAA1-12038QSHW31-A](#) [FAA1-12038QSLT31-A](#) [FAA1-12038QSLW31-A](#) [FAA1-12038QSMT31-A](#) [FAA1-](#)
[12038QSMW31-A](#)