

Jan.1.2021 Copyright 2021 HIROSE ELECTRIC CO., LTD. All Rights Reserved.
In case of consideration for using Automotive equipment / device which demand high reliability, kindly contact our sales window correspondents.

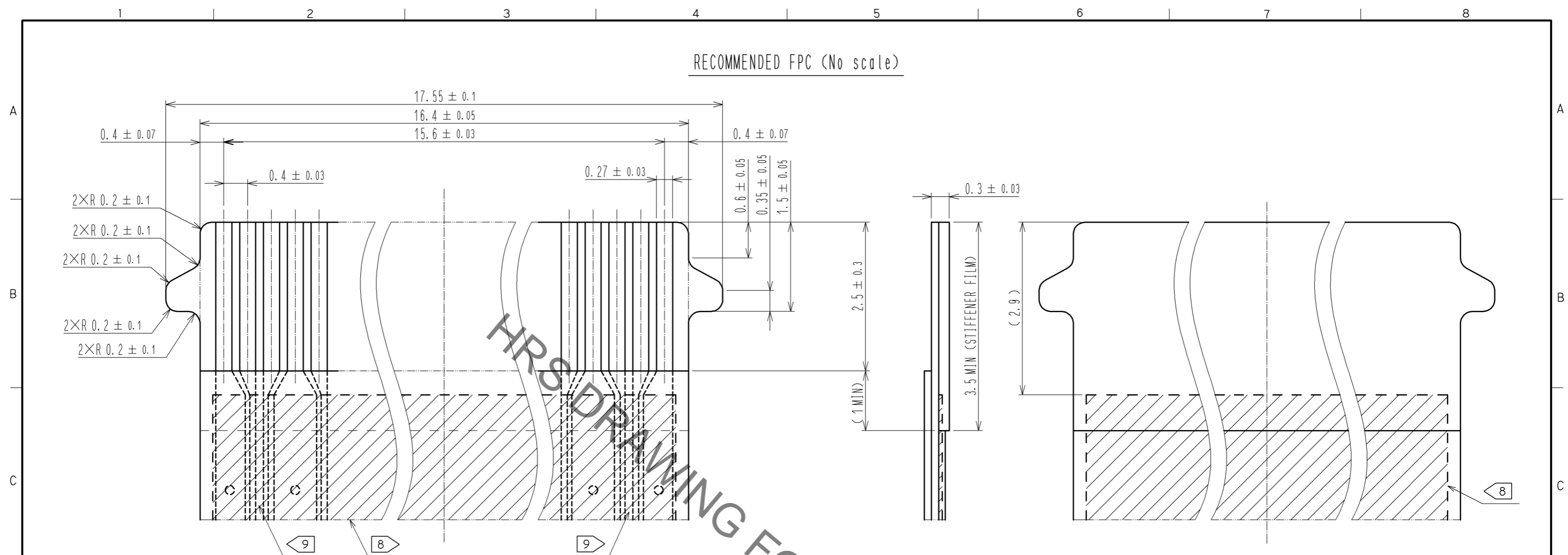

10 FPC CONFIGURATION (Reference example)

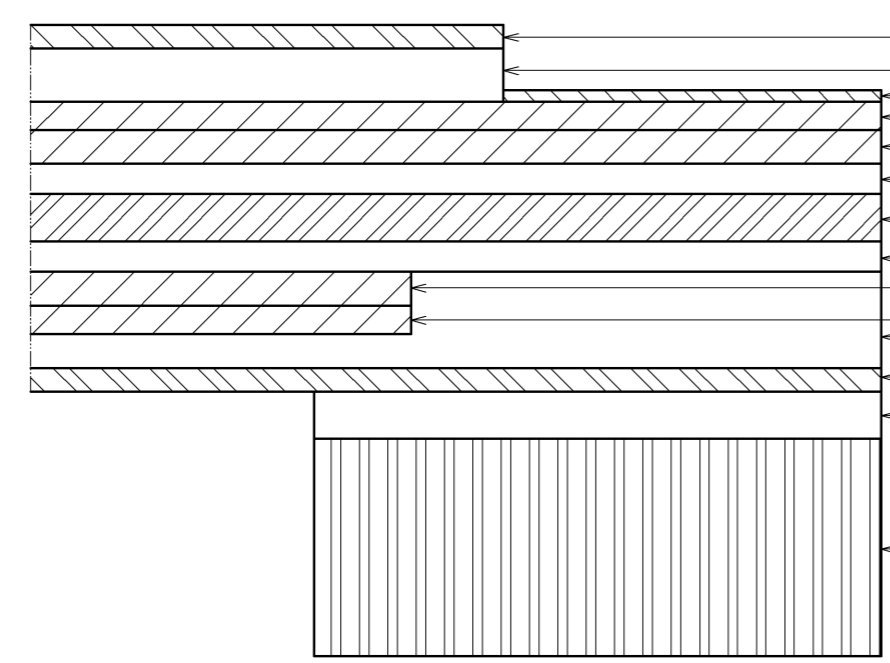

Material	Thickness (μm)		
	LCP 2-Layer CCL	Polyimide 2-Layer CCL	Polyimide 3-Layer CCL
① Cover Lay Film	12.5	12.5	12.5
② Cover Adhesive	28	28	28
③ Surface Treatment (Nickel Under Plating + Gold Plating)	(6)	(6)	(6)
④ Copper Plating (Through Hole Copper)	15	15	15
⑤ Pattern Copper Foil	9	18	18
⑥ Base Adhesive(Thermoset Adhesive)	-	-	16
⑦ Base Film 11	50	25	25
⑧ Base Adhesive(Thermoset Adhesive)	-	-	16
⑨ Ground Copper Foil	9	18	18
⑩ Copper Plating (Through Hole Copper)	15	15	15
⑪ Cover Adhesive(Thermoset Adhesive)	28	28	28
⑫ Cover Lay Film	12.5	12.5	12.5
⑬ Stiffener Adhesive (Thermoset Adhesive)	50	50	30
⑭ Stiffener Film	125	150	125
Total of Mating Area (③ to ⑧, ⑪ to ⑭)	295.5	304.5	291.5

- NOTES
- 8 This shaded area is ground copper foil.
 - 9 Match the impedance to your system conditions.
 - 10 FPC Configuration example is for reference. Applicable FPC mating area thickness is 0.3±0.03mm.
 - 11 This is reference examples of base film material. LCP means liquid crystalline polymer.

<RECOMMENDED FPC>

HRS	DRAWING NO.	EDC3-346728-00
	PART NO.	FH55M-40S-0.4SH
	CODE NO.	CL580-3706-4-00
		2/5

Jan.1.2021 Copyright 2021 HIROSE ELECTRIC CO., LTD. All Rights Reserved.
 In case of consideration for using Automotive equipment / device which demand high reliability, kindly contact our sales window correspondents.

EMBOSSED CARRIER TAPE DIMENSION (2:1)

REEL DIMENSIONS (No Scale)

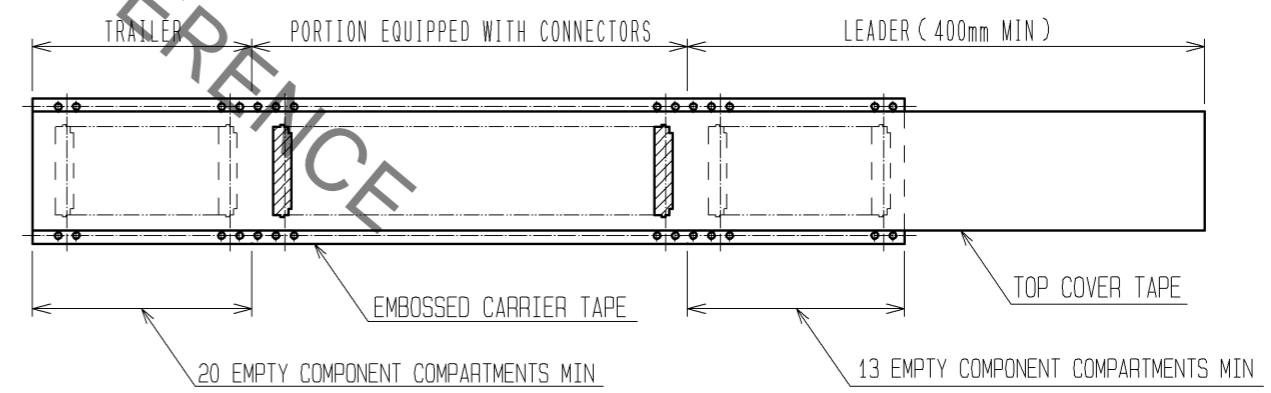
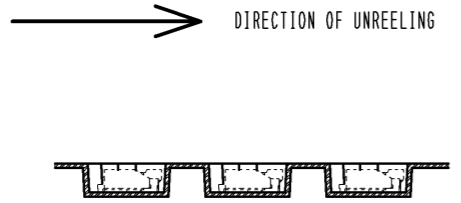
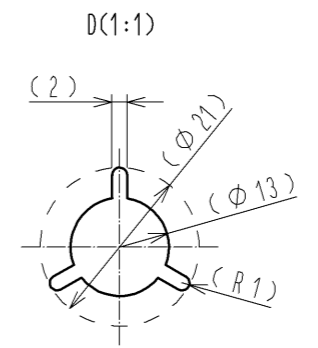
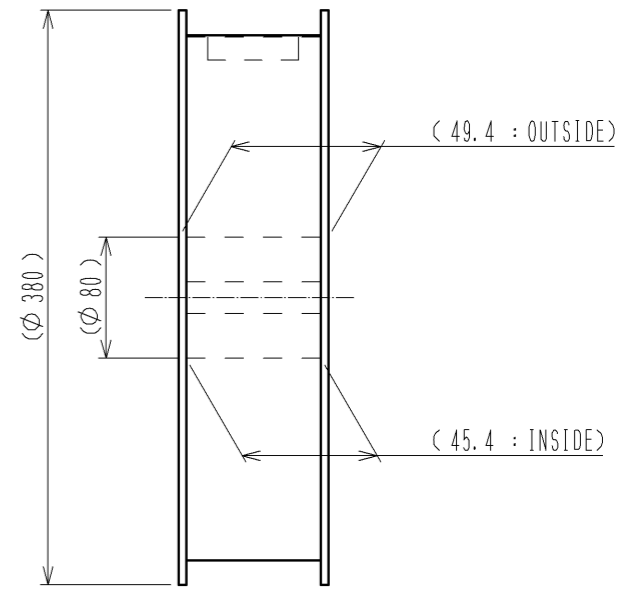
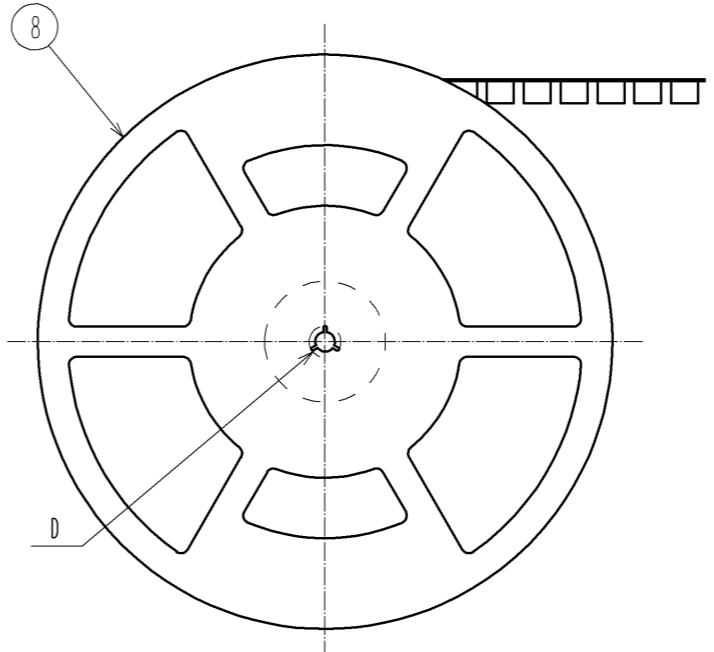
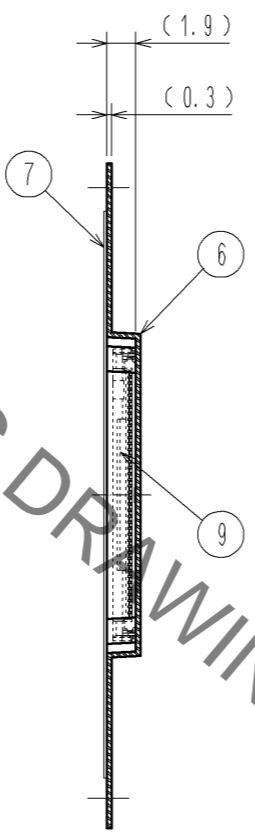
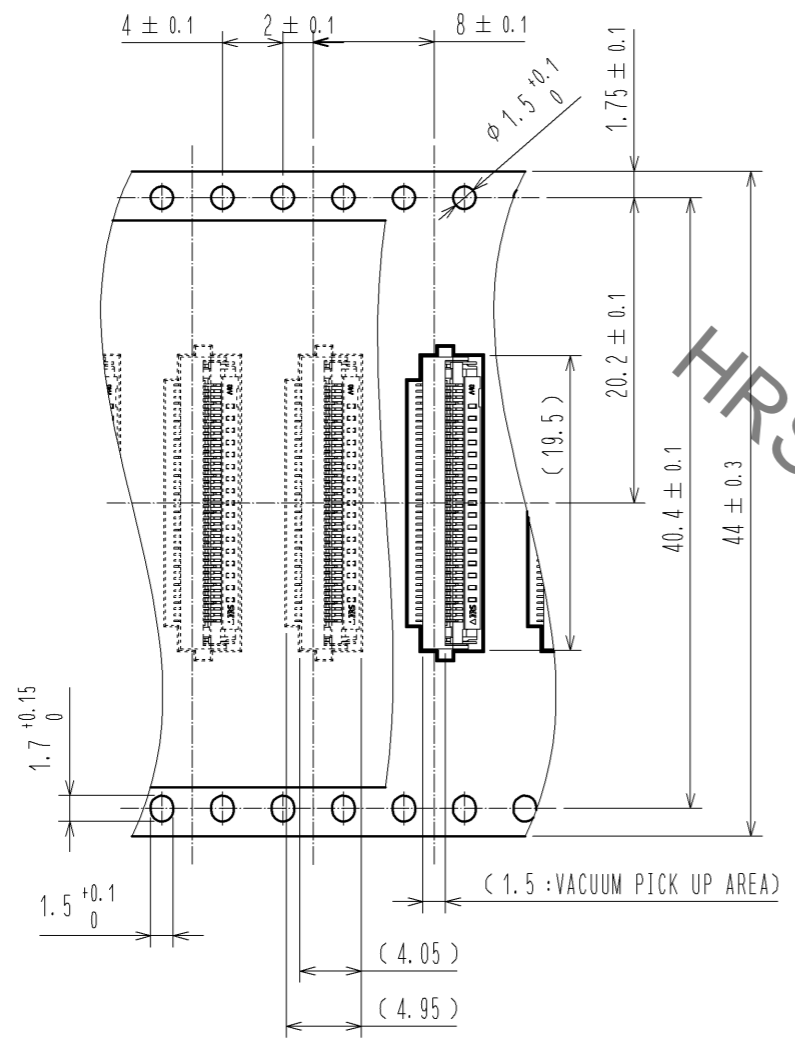

- NOTES 12. 1 reel : 5000 connectors.
 13. Refer to JIS C 0806. (Packaging of components for automatic handling.)

<DRAWING FOR PACKING>

HRS	DRAWING NO.	EDC3-346728-00
	PART NO.	FH55M-40S-0.4SH
	CODE NO.	CL580-3706-4-00

Jan.1.2021 Copyright 2021 HIROSE ELECTRIC CO., LTD. All Rights Reserved.
In case of consideration for using Automotive equipment / device which demand high reliability, kindly contact our sales window correspondents.

This connector requires delicate and careful handling.
Read through the instructions shown below and handle the connector properly.
Each values indicating here are for reference and may differ from standard value.

[INSTRUCTIONS FOR MOUNTING ON THE BOARD]

- ◆ Warp of Board
Minimize warp of the Board as much as possible.
Lead co-planarity including reinforced metal fittings is 0.1 mm or less.
Too much warp of the Board may result in a soldering failure.
- ◆ Load to Connector
Do not add 1N or greater external force when unreel or pick and place the connector etc.
or it may get broken.
In addition, do not insert the FPC or operate the connector before mounting it.
- ◆ Load to Board
· Splitting a large Board into several pieces
· Screwing the Board
Avoid the handling described above so that no force is exerted on the Board during the assembly process.
Otherwise, the connector may become defective.
- ◆ Amount of Warp
The warp of a 100mm wide Board should be 1 mm or less.
The warp of Board suffers stress on connector and the connector may become defective.

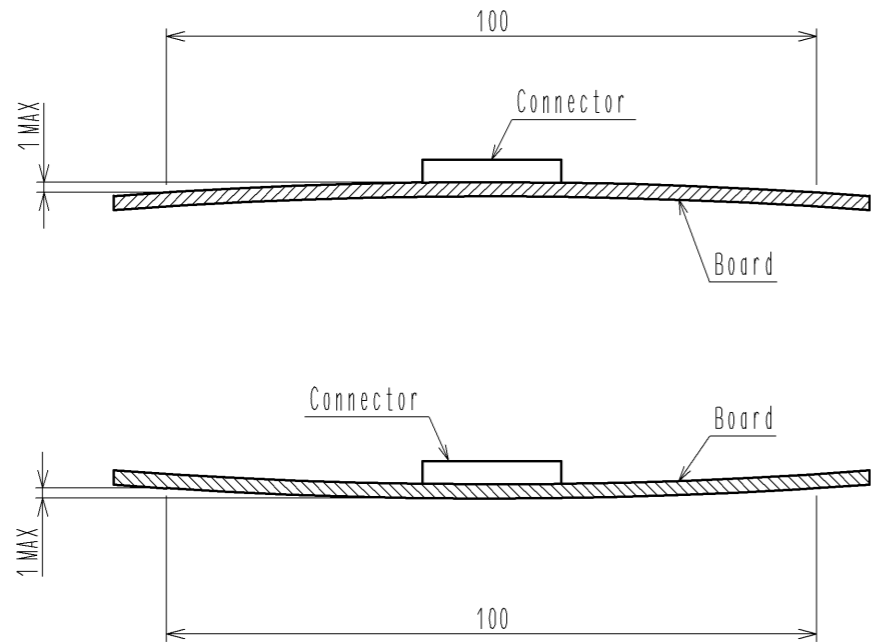

[INSTRUCTIONS ON INSERTING FPC AND CONNECTION]

- ◆ Use of the Actuator
1. Be very careful not to apply excessive force when releasing the actuator in the initial position.
If you use your nail or finger as shown below, the terminals may be deformed.

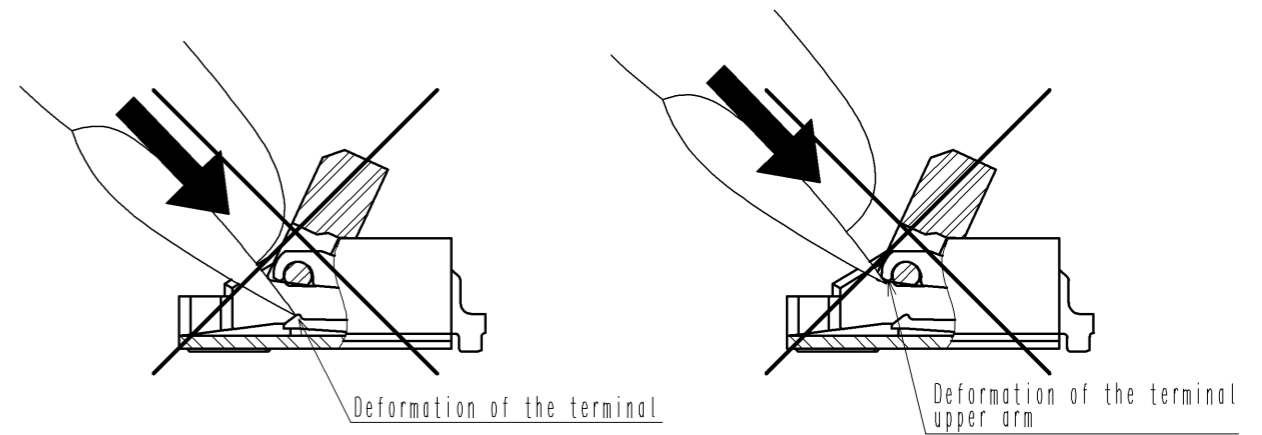

- 2. The actuator rotates around the rotational axis as shown below. Rotate the actuator.
- 3. The actuator will not open more than 115°. Do not apply any force backward beyond this point. Otherwise, the actuator may come off or break.

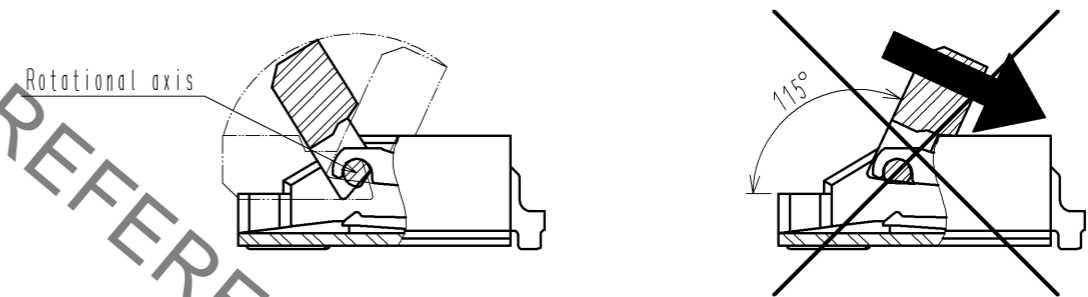

- 4. Move the actuator at approximately the center.
- 5. Do not pinch or pick the actuator to lift it as shown below. Otherwise, it may break. (Do not carry out any operation other than rotating the actuator as shown in 2 above.)

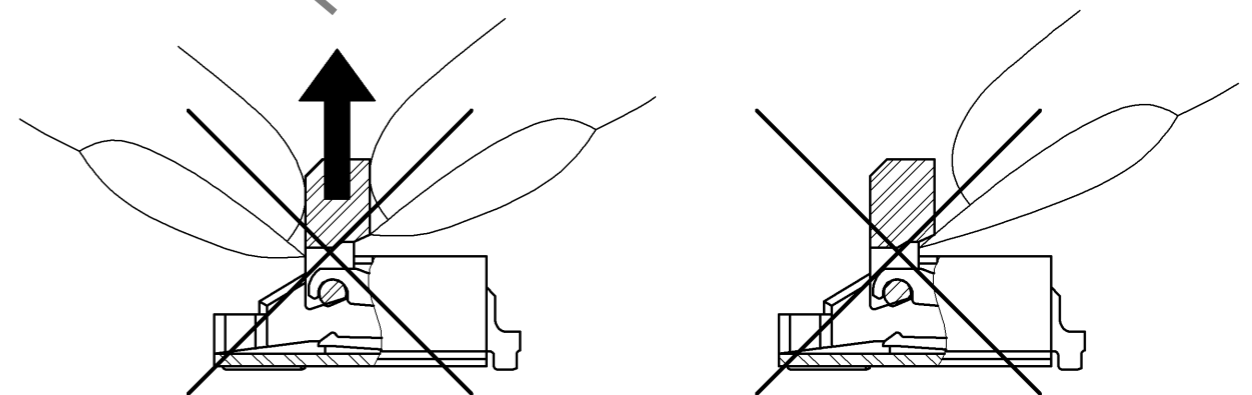

< INSTRUCTION MANUAL(1) >

HRS	DRAWING NO.	EDC3-346728-00
	PART NO.	FH55M-40S-0.4SH
	CODE NO.	CL580-3706-4-00
		4/5

Jan.1.2021 Copyright 2021 HIROSE ELECTRIC CO., LTD. All Rights Reserved.
In case of consideration for using Automotive equipment / device which demand high reliability, kindly contact our sales window correspondents.

◆ Direction of Contacts

This connector has contacts on the bottom. Thus, insert FPC with the exposed conductors face down.

◆ Inserting the FPC

1. Insert the FPC by about 12 degrees along the surface and at a right angle to the connector.
Insert it properly to the very end.

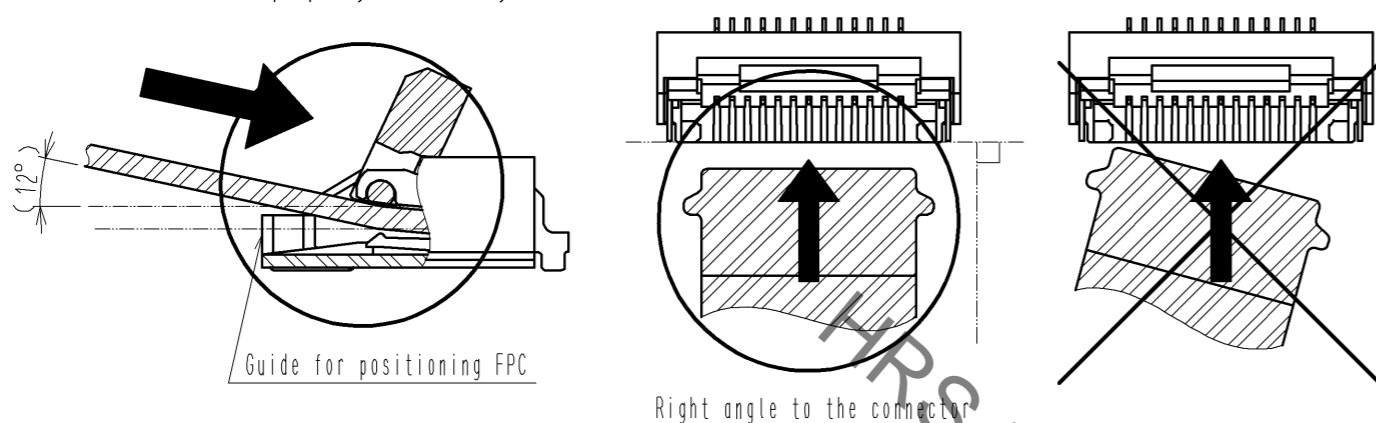

2. Do not insert the FPC diagonally from above.
If the FPC is inserted at a slant (incorrectly) as shown below in the FPC insertion process, the edge of the FPC may catch in the terminals, resulting in deformation of the terminals. The FPC may bend and patterns may break or the FPC may not insert completely, resulting in improper conduction.

※ Keep a sufficient FPC insertion space in the stage of the layout in order to avoid incorrect FPC insertion.

Besides, it is not difficult to insert FPC correctly all the way to the end.
Design the proper layout of parts.

※ Make adjustments with the FPC manufacturer for FPC bending performance and wire breakage.

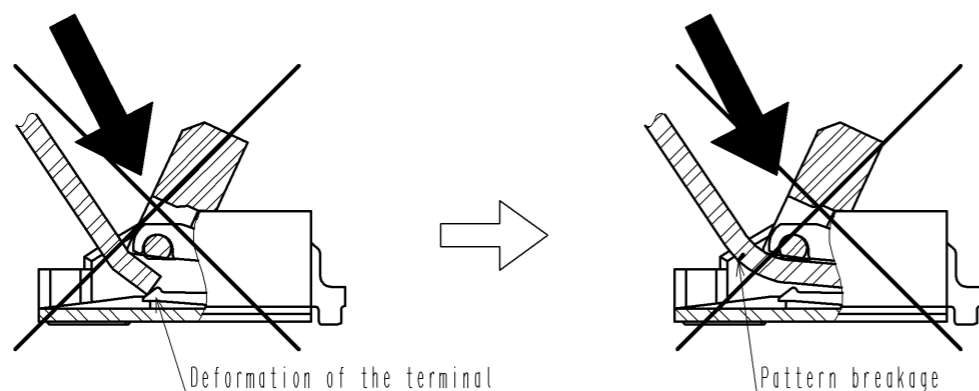

3. Do not rotate the actuator when FPC TAB is on right and left guides for positioning FPC.
Make sure the position of FPC TAB and guides before rotate the actuator.

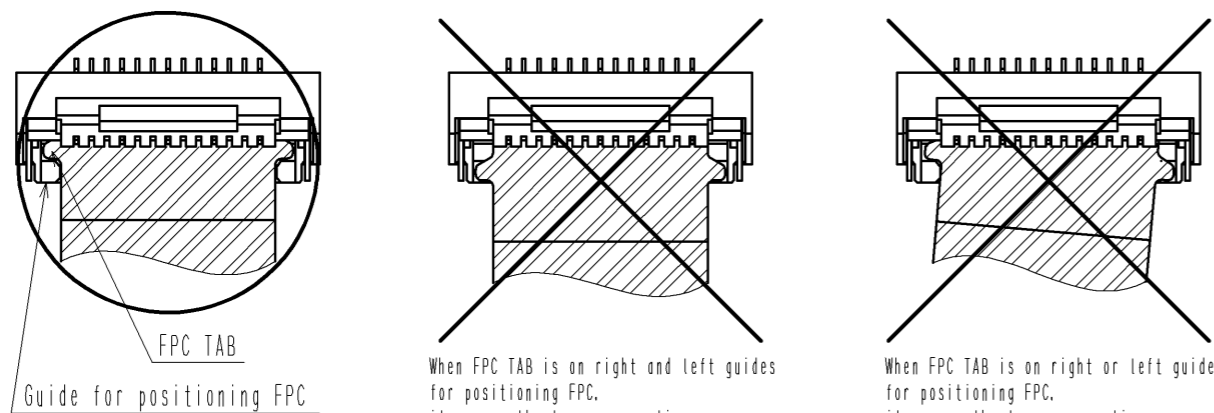

◆ Checking the Locking Condition

In the locked condition, make sure that the actuator is horizontal on the Board surface.
Do not apply excessive force to it near the 0° position of the actuator.
Otherwise, the terminals may be deformed.

[INSTRUCTIONS ON FPC LAYOUT AFTER CONNECTION]

◆ Load to FPC

Be very careful not to apply any force to the connector directly after inserting FPC.
Otherwise, the connector may become unlocked or the FPC may break.
In particular, design the FPC layout with care not to bend it sharply upward in a vertical direction near the insertion opening.
Fix the FPC when loads are applied to it continuously.

Load: $0.05 \times n$ N MAX
(n: number of contacts)

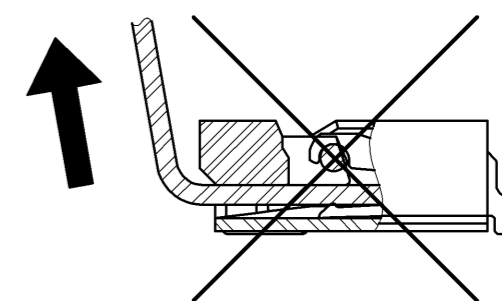

[INSTRUCTIONS ON REMOVING FPC]

◆ Move the actuator at approximately the center.

◆ Release the actuator to remove the FPC.
Remove the FPC by about 12 degrees along the surface.

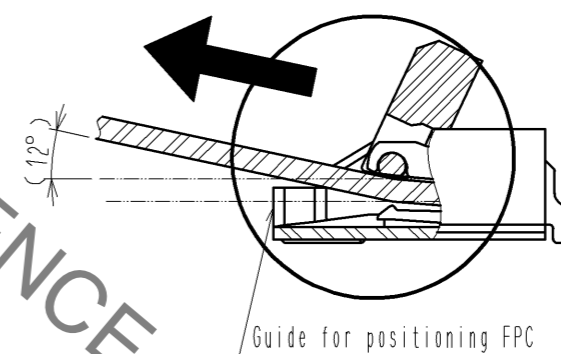

[OTHER INSTRUCTIONS]

◆ Instructions on Manual Soldering

Follow the instructions shown below when soldering the connector manually during repair work, etc.

1. Do not perform reflow soldering or manual soldering with the FPC inserted into the connector.
2. Do not heat the connector excessively. Be very careful not to let the soldering iron contact any parts other than connector leads. Otherwise, the connector may be deformed or melt.
3. Do not use excessive solder (or flux).
If excessive solder (or flux) is used on the terminals, solder or flux may adhere to the contacts or rotating parts of the actuator, resulting in poor contact or a rotation failure of the actuator. Supplying excessive solder to the reinforcing bracket may hinder actuator rotation, resulting in breakage of the connector.

<INSTRUCTION MANUAL(2)>

HRS	DRAWING NO.	EDC3-346728-00
	PART NO.	FH55M-40S-0.4SH
	CODE NO.	CL580-3706-4-00

Mouser Electronics

Authorized Distributor

Click to View Pricing, Inventory, Delivery & Lifecycle Information:

[Hirose Electric:](#)

[FH55M-40S-0.4SH](#)