PWM Step-Up DC/DC Controller

NO.EA-088-160113

OUTLINE

The R1211x is a CMOS-based PWM step-up DC/DC converter controller with low supply current. The R1211x consists of an oscillator, a PWM control circuit, a reference voltage unit, an error amplifier, a reference current unit, a protection circuit, and an under voltage lockout (UVLO) circuit. A low ripple and high efficiency step-up DC/DC converter can be configured by only adding few external components, such as an inductor, a diode, a power MOSFET, divider resistors, and capacitors. The R1211x002B/D has a built-in phase compensation, while the R1211x002A/C can set a phase compensation externally. The R1211x002B/D has stand-by mode. The max duty cycle is internally fixed at 90% typically. A soft-start function is built-in, and a soft-starting time is set at 9 ms typically (R1211x002A/B, 700 kHz) or 10.5 ms typically (R1211xC/D, 300 kHz). The R1211x has a latch-type protection circuit, which latches the external driver in off-state if the maximum duty cycle continues for a specified time after soft-starting time. The protection delay time can be set with an external capacitor. To release the protection, turn the power off and back on (power source voltage lower than UVLO detector threshold) or make the device into standby mode and back to active mode using the CE pin.

FEATURES

- Input Voltage Range2.5 V to 6.0 V
- Oscillator Frequency (PWM Control).....300 kHz, 700 kHz
- Maximum Duty Cycle.....Typ. 90%
- Standby CurrentTyp. 0 μ A (R1211x002B/D)
- Feedback Voltage.....1.0 V
- Feedback Voltage Accuracy \pm 1.5%
- UVLO Threshold LevelTyp. 2.2 V (Hysteresis Typ. 0.13 V)
- Feedback Voltage Temperature Coefficient..... \pm 150 ppm/ $^{\circ}$ C
- Built-in Latch-type Protection CircuitProtection delay time can be set with an external capacitor
- PackagesSON-6, SOT-23-6W

APPLICATIONS

- Constant Voltage Power Source for Portable Equipment
- Constant Voltage Power Source for LCD and CCD

R1211x

NO.EA-088-160113

BLOCK DIAGRAMS

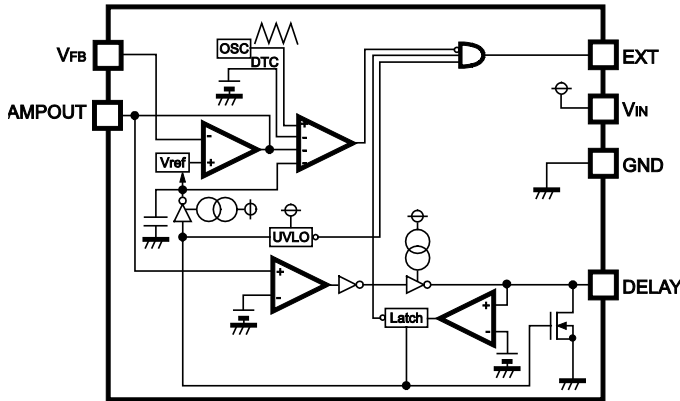

R1211x002A/C Block Diagram

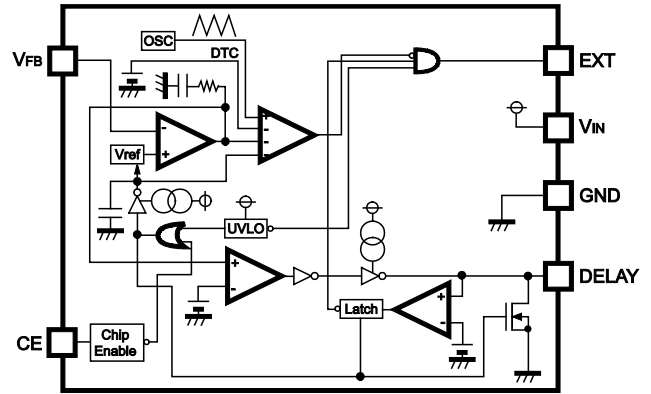

R1211x002B/D Block Diagram

SELECTION GUIDE

In the R1211x, the oscillator frequency, the optional function, and the package type are user-selectable options.

Selection Guide

Product Name	Package	Quantity per Reel	Pb Free	Halogen Free
R1211D002x-TR-FE	SON-6	3,000 pcs	Yes	Yes
R1211N002x-TR-FE	SOT-23-6W	3,000 pcs	Yes	Yes

x: Designation of Oscillator Frequency and Optional Function

- (A) 700 kHz, with AMPOUT pin (External Phase Compensation Type)
- (B) 700 kHz, with CE pin (Internal Phase Compensation Type, with Standby)
- (C) 300 kHz, with AMPOUT pin (External Phase Compensation Type)
- (D) 300 kHz, with CE pin (Internal Phase Compensation Type, with Standby)

PIN CONFIGURATIONS

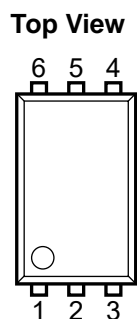

SON-6 Pin Configuration

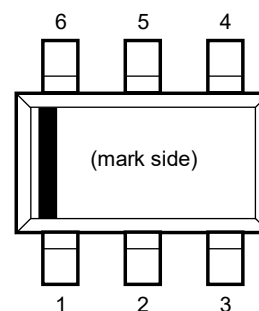
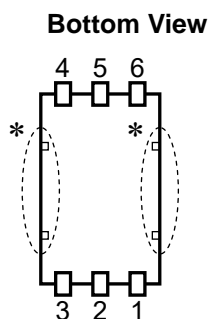

SOT-23-6W Pin Configuration

PIN DESCRIPTIONS

Pin Descriptions

Symbol	Pin No				Pin Description
	R1211x002A/C		R1211x002B/D		
	SON-6	SOT-23-6W	SON-6	SOT-23-6W	
DELAY	1	1	1	1	Pin for External Capacitor (for Setting Output Delay Time of Protection)
GND	2	5	2	5	Ground Pin
EXT	3	6	3	6	External FET Drive Pin (CMOS Output)
V _{IN}	4	4	4	4	Power Supply Pin
V _{FB}	5	3	5	3	Feedback Pin for Monitoring Output Voltage
AMPOUT	6	2	-	-	Amplifier Output Pin
CE	-	-	6	2	Chip Enable Pin ("H" Active)

* Tab suspension leads in the  parts have GND level. (They are connected to the reverse side of this IC.)
Do not connect to other wires or land patterns.

ABSOLUTE MAXIMUM RATINGS**Absolute Maximum Ratings**

(GND = 0 V)

Symbol	Item	Rating	Unit	
V_{IN}	V_{IN} Pin Voltage	6.5	V	
V_{EXT}	EXT Pin Output Voltage	-0.3 ~ $V_{IN}+0.3$	V	
V_{DLY}	DELAY Pin Voltage	-0.3 ~ $V_{IN}+0.3$	V	
V_{AMP}	AMPOUT Pin Voltage	-0.3 ~ $V_{IN}+0.3$	V	
V_{CE}	CE Pin Input Voltage	-0.3 ~ $V_{IN}+0.3$	V	
V_{FB}	V_{FB} Pin Voltage	-0.3 ~ $V_{IN}+0.3$	V	
I_{AMP}	AMPOUT Pin Current	± 10	mA	
I_{EXT}	EXT Pin Inductor Drive Output Current	± 50	mA	
P_D	Power Dissipation (Standard Land Pattern)*	SOT-23-6W	430	mW
		SON-6	500	
T_{opt}	Operating Temperature Range	-40 ~ +85	°C	
T_{stg}	Storage Temperature Range	-55 ~ +125	°C	

* For Power Dissipation, please refer to *PACKAGE INFORMATION*.**ABSOLUTE MAXIMUM RATINGS**

Electronic and mechanical stress momentarily exceeded absolute maximum ratings may cause the permanent damages and may degrade the life time and safety for both device and system using the device in the field. The functional operation at or over these absolute maximum ratings is not assured.

ELECTRICAL CHARACTERISTICS

R1211x002A Electrical Characteristics

(T_{opt} = 25°C)

Symbol	Item	Conditions	Min.	Typ.	Max.	Unit
V _{IN}	Operating Input Voltage		2.5		6.0	V
V _{FB}	Feedback Voltage	V _{IN} =3.3V	0.985	1.000	1.015	V
$\frac{\Delta V_{FB}}{\Delta T_{opt}}$	V _{FB} Voltage Temperature Coefficient	-40°C ≤ T _{opt} ≤ 85°C		±150		ppm/°C
I _{FB}	V _{FB} Input Current	V _{IN} =6V, V _{FB} =0V or 6V	-0.1		0.1	μA
f _{OSC}	Oscillator Frequency	V _{IN} =3.3V, V _{DLY} =V _{FB} =0V	595	700	805	kHz
$\frac{\Delta f_{OSC}}{\Delta T_{opt}}$	Oscillator Frequency Temperature Coefficient	-40°C ≤ T _{opt} ≤ 85°C		±1.4		kHz/°C
I _{DD1}	Supply Current 1	V _{IN} =6V, V _{DLY} =V _{FB} =0V, EXT at no load		600	900	μA
maxdty	Maximum Duty Cycle	V _{IN} =3.3V, EXT "H" side	82	90	94	%
R _{EXTH}	EXT "H" ON Resistance	V _{IN} =3.3V, I _{EXT} =-20mA		5	10	Ω
R _{EXTL}	EXT "L" ON Resistance	V _{IN} =3.3V, I _{EXT} =20mA		3	6	Ω
I _{DLY1}	Delay Pin Charge Current	V _{IN} =3.3V, V _{DLY} =V _{FB} =0V	2.5	5.0	7.5	μA
I _{DLY2}	Delay Pin Discharge Current	V _{IN} =V _{FB} =2.5V, V _{DLY} =0.1V	2.5	5.5	9.0	mA
V _{DLY}	Delay Pin Detector Threshold	V _{IN} =3.3V, V _{FB} =0V, V _{DLY} =0V→2V	0.95	1.00	1.05	V
T _{START}	Soft-start Time	V _{IN} =3.3V at 90% of rising edge	4.5	9.0	13.5	ms
V _{UVLO}	UVLO Detector Threshold	V _{IN} =2.5V→2V, V _{DLY} =V _{FB} =0V	2.1	2.2	2.3	V
V _{HYS}	UVLO Detector Hysteresis	V _{IN} =2V→2.5V, V _{DLY} =V _{FB} =0V	0.08	0.13	0.18	V
I _{AMP1}	AMP "H" Output Current	V _{IN} =3.3V, V _{AMP} =1V, V _{FB} =0.9V	0.45	0.90	1.50	mA
I _{AMP2}	AMP "L" Output Current	V _{IN} =3.3V, V _{AMP} =1V, V _{FB} =1.1V	30	60	90	μA

RECOMMENDED OPERATING CONDITIONS (ELECTRICAL CHARACTERISTICS)

All of electronic equipment should be designed that the mounted semiconductor devices operate within the recommended operating conditions. The semiconductor devices cannot operate normally over the recommended operating conditions, even if when they are used over such conditions by momentary electronic noise or surge. And the semiconductor devices may receive serious damage when they continue to operate over the recommended operating conditions.

R1211x

NO.EA-088-160113

R1211x002B Electrical Characteristics(T_{opt} = 25°C)

Symbol	Item	Conditions	Min.	Typ.	Max.	Unit
V _{IN}	Operating Input Voltage		2.5		6.0	V
V _{FB}	Feedback Voltage	V _{IN} =3.3V	0.985	1.000	1.015	V
$\frac{\Delta V_{FB}}{\Delta T_{opt}}$	V _{FB} Voltage Temperature Coefficient	-40°C ≤ T _{opt} ≤ 85°C		±150		ppm/°C
I _{FB}	VFB Input Current	V _{IN} =6V, V _{FB} =0V or 6V	-0.1		0.1	μA
f _{OSC}	Oscillator Frequency	V _{IN} =3.3V, V _{DLY} =V _{FB} =0V	595	700	805	kHz
$\frac{\Delta f_{osc}}{\Delta T_{opt}}$	Oscillator Frequency Temperature Coefficient	-40°C ≤ T _{opt} ≤ 85°C		±1.4		kHz/°C
I _{DD1}	Supply Current 1	V _{IN} =6V, V _{DLY} =V _{FB} =0V, EXT at no load		600	900	μA
maxdty	Maximum Duty Cycle	V _{IN} =3.3V, EXT "H" side	82	90	94	%
R _{EXTH}	EXT "H" ON Resistance	V _{IN} =3.3V, I _{EXT} =-20mA		5	10	Ω
R _{EXTL}	EXT "L" ON Resistance	V _{IN} =3.3V, I _{EXT} =20mA		3	6	Ω
I _{DLY1}	Delay Pin Charge Current	V _{IN} =3.3V, V _{DLY} =V _{FB} =0V	2.5	5.0	7.5	μA
I _{DLY2}	Delay Pin Discharge Current	V _{IN} =V _{FB} =2.5V, V _{DLY} =0.1V	2.5	5.5	9.0	mA
V _{DLY}	Delay Pin Detector Threshold	V _{IN} =3.3V, V _{FB} =0V, V _{DLY} =0V→2V	0.95	1.00	1.05	V
T _{START}	Soft-start Time	V _{IN} =3.3V	4.5	9.0	13.5	ms
V _{UVLO}	UVLO Detector Threshold	V _{IN} =2.5V→2V, V _{DLY} =V _{FB} =0V	2.1	2.2	2.3	V
V _{HYS}	UVLO Detector Hysteresis	V _{IN} =2V→2.5V, V _{DLY} =V _{FB} =0V	0.08	0.13	0.18	V
I _{STB}	Standby Current	V _{IN} =6V, V _{CE} =0V		0	1	μA
I _{CEH}	CE "H" Input Current	V _{IN} =6V, V _{CE} =6V	-0.5		0.5	μA
I _{CEL}	CE "L" Input Current	V _{IN} =6V, V _{CE} =0V	-0.5		0.5	μA
V _{CEH}	CE "H" Input Voltage	V _{IN} =6V, V _{CE} =0V→6V	1.5			V
V _{CEL}	CE "L" Input Voltage	V _{IN} =2.5V, V _{CE} =2V→0V			0.3	V

RECOMMENDED OPERATING CONDITIONS (ELECTRICAL CHARACTERISTICS)

All of electronic equipment should be designed that the mounted semiconductor devices operate within the recommended operating conditions. The semiconductor devices cannot operate normally over the recommended operating conditions, even if when they are used over such conditions by momentary electronic noise or surge. And the semiconductor devices may receive serious damage when they continue to operate over the recommended operating conditions.

R1211x002C Electrical Characteristics

(T_{opt} = 25°C)

Symbol	Item	Conditions	Min.	Typ.	Max.	Unit
V _{IN}	Operating Input Voltage		2.5		6.0	V
V _{FB}	V _{FB} Voltage Tolerance	V _{IN} =3.3V	0.985	1.000	1.015	V
$\frac{\Delta V_{FB}}{\Delta T_{opt}}$	V _{FB} Voltage Temperature Coefficient	-40°C ≤ T _{opt} ≤ 85°C		±150		ppm/°C
I _{FB}	VFB Input Current	V _{IN} =6V, V _{FB} =0V or 6V	-0.1		0.1	μA
f _{OSC}	Oscillator Frequency	V _{IN} =3.3V, V _{DLY} =V _{FB} =0V	240	300	360	kHz
$\frac{\Delta f_{osc}}{\Delta T_{opt}}$	Oscillator Frequency Temperature Coefficient	-40°C ≤ T _{opt} ≤ 85°C		±0.6		kHz/°C
I _{DD1}	Supply Current 1	V _{IN} =6V, V _{DLY} =V _{FB} =0V, EXT at no load		300	500	μA
maxdty	Maximum Duty Cycle	V _{IN} =3.3V, EXT "H" side	82	90	94	%
R _{EXTH}	EXT "H" ON Resistance	V _{IN} =3.3V, I _{EXT} =-20mA		5	10	Ω
R _{EXTL}	EXT "L" ON Resistance	V _{IN} =3.3V, I _{EXT} =20mA		3	6	Ω
I _{DLY1}	Delay Pin Charge Current	V _{IN} =3.3V, V _{DLY} =V _{FB} =0V	2.0	4.5	7.0	μA
I _{DLY2}	Delay Pin Discharge Current	V _{IN} =V _{FB} =2.5V, V _{DLY} =0.1V	2.5	5.5	9.0	mA
V _{DLY}	Delay Pin Detector Threshold	V _{IN} =3.3V, V _{FB} =0V, V _{DLY} =0V→2V	0.95	1.00	1.05	V
T _{START}	Soft-start Time	V _{IN} =3.3V	5.0	10.5	16.0	ms
V _{UVLO}	UVLO Detector Threshold	V _{IN} =2.5V→2V, V _{DLY} =V _{FB} =0V	2.1	2.2	2.3	V
V _{HYS}	UVLO Detector Hysteresis	V _{IN} =2V→2.5V, V _{DLY} =V _{FB} =0V	0.08	0.13	0.18	V
I _{AMP1}	AMP "H" Output Current	V _{IN} =3.3V, V _{AMP} =1V, V _{FB} =0.9V	0.45	0.90	1.50	mA
I _{AMP2}	AMP "L" Output Current	V _{IN} =3.3V, V _{AMP} =1V, V _{FB} =1.1V	25	50	75	μA

RECOMMENDED OPERATING CONDITIONS (ELECTRICAL CHARACTERISTICS)

All of electronic equipment should be designed that the mounted semiconductor devices operate within the recommended operating conditions. The semiconductor devices cannot operate normally over the recommended operating conditions, even if when they are used over such conditions by momentary electronic noise or surge. And the semiconductor devices may receive serious damage when they continue to operate over the recommended operating conditions.

R1211x

NO.EA-088-160113

R1211x002D Electrical Characteristics(T_{opt} = 25°C)

Symbol	Item	Conditions	Min.	Typ.	Max.	Unit
V _{IN}	Operating Input Voltage		2.5		6.0	V
V _{FB}	V _{FB} Voltage Tolerance	V _{IN} =3.3V	0.985	1.000	1.015	V
$\frac{\Delta V_{FB}}{\Delta T_{opt}}$	V _{FB} Voltage Temperature Coefficient	-40°C ≤ T _{opt} ≤ 85°C		±150		ppm/°C
I _{FB}	V _{FB} Input Current	V _{IN} =6V, V _{FB} =0V or 6V	-0.1		0.1	μA
f _{OSC}	Oscillator Frequency	V _{IN} =3.3V, V _{DLY} =V _{FB} =0V	240	300	360	kHz
$\frac{\Delta f_{osc}}{\Delta T_{opt}}$	Oscillator Frequency Temperature Coefficient	-40°C ≤ T _{opt} ≤ 85°C		±0.6		kHz/°C
I _{DD1}	Supply Current 1	V _{IN} =6V, V _{DLY} =V _{FB} =0V, EXT at no load		300	500	μA
maxdty	Maximum Duty Cycle	V _{IN} =3.3V, EXT "H" side	82	90	94	%
R _{EXTH}	EXT "H" ON Resistance	V _{IN} =3.3V, I _{EXT} =-20mA		5	10	Ω
R _{EXTL}	EXT "L" ON Resistance	V _{IN} =3.3V, I _{EXT} =20mA		3	6	Ω
I _{DLY1}	Delay Pin Charge Current	V _{IN} =3.3V, V _{DLY} =V _{FB} =0V	2.0	4.5	7.0	μA
I _{DLY2}	Delay Pin Discharge Current	V _{IN} =V _{FB} =2.5V, V _{DLY} =0.1V	2.5	5.5	9.0	mA
V _{DLY}	Delay Pin Detector Threshold	V _{IN} =3.3V, V _{FB} =0V, V _{DLY} =0V→2V	0.95	1.00	1.05	V
T _{START}	Soft-start Time	V _{IN} =3.3V	5.0	10.5	16.0	ms
V _{UVLO}	UVLO Detector Threshold	V _{IN} =2.5V→2V, V _{DLY} =V _{FB} =0V	2.1	2.2	2.3	V
V _{HYS}	UVLO Detector Hysteresis	V _{IN} =2V→2.5V, V _{DLY} =V _{FB} =0V	0.08	0.13	0.18	V
I _{STB}	Standby Current	V _{IN} =6V, V _{CE} =0V		0	1	μA
I _{CEH}	CE "H" Input Current	V _{IN} =6V, V _{CE} =6V	-0.5		0.5	μA
I _{CEL}	CE "L" Input Current	V _{IN} =6V, V _{CE} =0V	-0.5		0.5	μA
V _{CEH}	CE "H" Input Voltage	V _{IN} =6V, V _{CE} =0V→6V	1.5			V
V _{CEL}	CE "L" Input Voltage	V _{IN} =2.5V, V _{CE} =2V→0V			0.3	V

RECOMMENDED OPERATING CONDITIONS (ELECTRICAL CHARACTERISTICS)

All of electronic equipment should be designed that the mounted semiconductor devices operate within the recommended operating conditions. The semiconductor devices cannot operate normally over the recommended operating conditions, even if when they are used over such conditions by momentary electronic noise or surge. And the semiconductor devices may receive serious damage when they continue to operate over the recommended operating conditions.

TYPICAL APPLICATIONS AND TECHNICAL NOTES

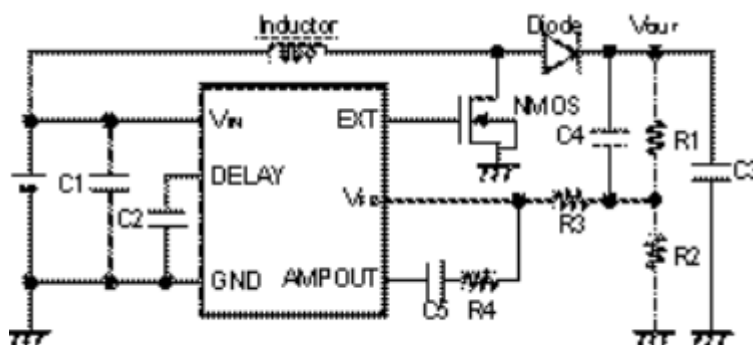

R1211x002A/R1211x002C Typical Application

NMOS: IRF7601 (International Rectifier)

Inductor: VLF504012MT-100M (TDK: 10 μ H) R1211x002A

VLF504012MT-220M (TDK: 22 μ H) R1211x002C

Diode: CRS10I30A (TOSHIBA)

C1: 4.7 μ F (Ceramic)

C2: 0.22 μ F (Ceramic)

C3: 10 μ F (Ceramic)

C4: 680 pF (Ceramic)

C5: 2200 pF (Ceramic)

R1: Output Voltage Setting Resistor 1

R2: Output Voltage Setting Resistor 2

R3: 30 k Ω

R4: 30 k Ω

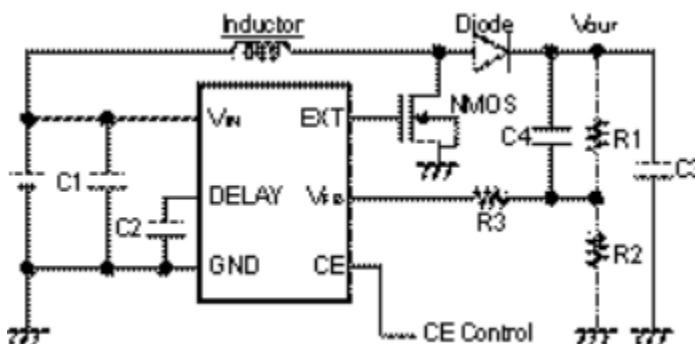

R1211x002B/R1211x002D Typical Application

NMOS: IRF7601 (International Rectifier)

Inductor: VLF504012MT-100M (TDK: 10 μ H) R1211x002B

VLF504012MT-220M (TDK: 22 μ H) R1211x002D

Diode: CRS10I30A (TOSHIBA)

C1: 4.7 μ F (Ceramic)

C2: 0.22 μ F (Ceramic)

C3: 10 μ F (Ceramic)

C4: 680 pF (Ceramic)

R1: Output Voltage Setting Resistor 1

R2: Output Voltage Setting Resistor 2

R3: 30 k Ω

[Note] These example circuits may be applied to the output voltage requirement is 15 V or less. If the output voltage requirement is 15 V or more, ratings of NMOS and diode as shown above is over the limit, therefore, choose other external components.

R1211x

NO.EA-088-160113

- Use a 1 μ F or more capacitance value of bypass capacitor between VIN pin and GND, C1 as shown in the typical applications above.
 - In terms of the capacitor for setting delay time of the latch protection, C2 as shown in typical applications of the previous page, connect between Delay pin and GND pin of the IC with the minimum wiring distance.
 - Connect a 1 μ F or more value of capacitor between VOUT and GND, C3 as shown in typical applications of the previous page. (Recommended value is from 10 μ F to 22 μ F.) If the operation of the composed DC/DC converter may be unstable, use a tantalum type capacitor instead of ceramic type.
 - Connect a capacitor between VOUT and the dividing point, C4 as shown in typical applications of the previous page. The capacitance value of C4 depends on divider resistors for output voltage setting. Typical value is between 100 pF and 1000 pF.
 - The output voltage can be set with divider resistors for voltage setting, R1 and R2 as shown in typical applications of the previous page. Refer to the next formula.
Output Voltage = $V_{FB} \times (R1 + R2) / R2$
R1 + R2 = 100 k Ω is recommended range of resistances.
 - The operation of latch protection circuit is as follows: When the IC detects maximum duty cycle, charge to an external capacitor, C2 of DELAY pin starts. And maximum duty cycle continues and the voltage of DELAY pin reaches delay voltage detector threshold, V_{DLY} , outputs "L" to EXT pin and turns off the external power MOSFET. To release the latch protection operation, make the IC be standby mode with CE pin and make it active in terms of R1211x002B/D version. Otherwise, restart with power on.
 - The delay time of latch protection can be calculated with C2, V_{DLY} , and Delay Pin Charge Current, I_{DLY1} , as in the next formula.
 $t = C2 \times V_{DLY} / I_{DLY1}$
Once after the maximum duty is detected and released before delay time, charge to the capacitor is halt and delay pin outputs "L".
 - As for R1211x002A/C version, the values and positioning of C4, C5, R3, and R4 shown in the above diagram are just an example combination. These are for making phase compensation. If the spike noise of VOUT may be large, the spike noise may be picked into VFB pin and make the operation unstable. In this case, a resistor R3, shown in typical applications of the previous page. The recommended resistance value of R3 is in the range from 10 k Ω to 50 k Ω . Then, noise level will be decreased.
 - As for R1211x002B/D version, EXT pin outputs GND level at standby mode.
 - Select the Power MOSFET, the diode, and the inductor within ratings (Voltage, Current, Power) of this IC. Choose the power MOSFET with low threshold voltage depending on Input Voltage to be able to turn on the FET completely. Choose the diode with low V_F such as Shottky type with low reverse current I_R , and with fast switching speed. When an external transistor is switching, spike voltage may be generated caused by an inductor, therefore recommended voltage tolerance of capacitor connected to VOUT is three times of setting voltage or more.
- * The performance of power circuit with using this IC depends on external components. Choose the most suitable components for your application.

OUTPUT CURRENT AND SELECTION OF EXTERNAL COMPONENTS

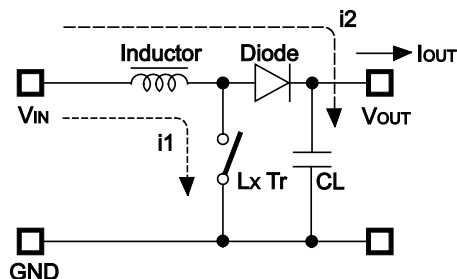

Basic Circuit

Circuit through L

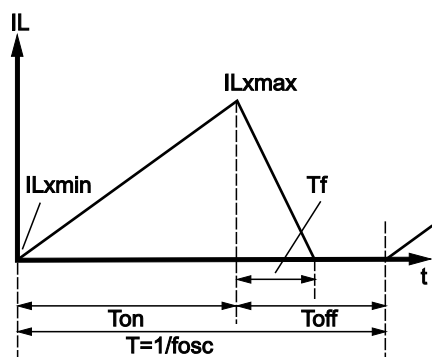

Discontinuous Mode

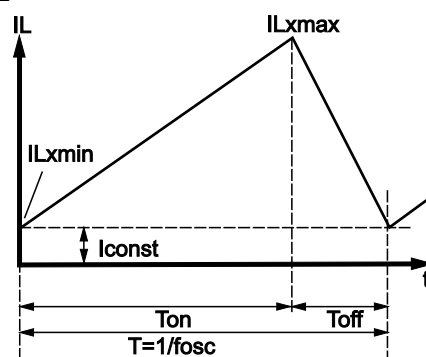

Continuous Mode

There are two modes, or discontinuous mode and continuous mode for the PWM step-up switching regulator depending on the continuous characteristic of inductor current.

During on time of the transistor, when the voltage added on to the inductor is described as V_{IN} , the current is $V_{IN} \times t / L$. Therefore, the electric power, P_{ON} , which is supplied with input side, can be described as in next formula.

$$P_{ON} = \int_0^{T_{on}} V_{IN}^2 \times t/L \, dt \dots\dots\dots \text{Formula 1}$$

With the step-up circuit, electric power is supplied from power source also during off time. In this case, input current is described as $(V_{OUT} - V_{IN}) \times t / L$, therefore electric power, P_{OFF} is described as in next formula.

$$P_{OFF} = \int_0^{T_f} V_{IN} \times (V_{OUT} - V_{IN}) \times t/L \, dt \dots\dots\dots \text{Formula 2}$$

In this formula, T_f means the time of which the energy saved in the inductance is being emitted. Thus average electric power, P_{AV} is described as in the next formula.

$$P_{AV} = 1/(T_{ON} + T_{OFF}) \times \left\{ \int_0^{T_{on}} V_{IN}^2 \times t/L \, dt + \int_0^{T_f} V_{IN} \times (V_{OUT} - V_{IN}) \times t/L \, dt \right\} \dots\dots\dots \text{Formula 3}$$

In PWM control, when $T_f = T_{off}$ is true, the inductor current becomes continuous, then the operation of switching regulator becomes continuous mode.

In the continuous mode, the deviation of the current is equal between on time and off time.

$$V_{IN} \times T_{ON}/L = (V_{OUT} - V_{IN}) \times T_{OFF}/L \dots\dots\dots \text{Formula 4}$$

Further, the electric power, P_{AV} is equal to output electric power, $V_{OUT} \times I_{OUT}$, thus,

$$I_{OUT} = f_{OSC} \times V_{IN}^2 \times T_{ON}^2 / \{2 \times L \times (V_{OUT} - V_{IN})\} = V_{IN}^2 \times T_{ON} / (2 \times L \times V_{OUT}) \dots\dots\dots \text{Formula 5}$$

When I_{OUT} becomes more than formula 5, the current flows through the inductor, then the mode becomes continuous. The continuous current through the inductor is described as I_{CONST} , then,

$$I_{OUT} = f_{OSC} \times V_{IN}^2 \times T_{ON}^2 / \{2 \times L \times (V_{OUT} - V_{IN})\} + V_{IN} \times I_{CONST} / V_{OUT} \dots\dots\dots \text{Formula 6}$$

In this moment, the peak current, I_{LXMAX} flowing through the inductor and the driver T_r is described as follows:

$$I_{LXMAX} = I_{CONST} + V_{IN} \times T_{ON} / L \dots\dots\dots \text{Formula 7}$$

With the formula 4 and 6, I_{LXMAX} is,

$$I_{LXMAX} = V_{OUT} / V_{IN} \times I_{OUT} + V_{IN} \times T_{ON} / (2 \times L) \dots\dots\dots \text{Formula 8}$$

Therefore, peak current is more than I_{OUT} . Considering the value of I_{LXMAX} , the condition of input and output, and external components should be selected. In the formula 7, peak current I_{LXMAX} at discontinuous mode can be calculated. Put $I_{CONST} = 0$ in the formula. The explanation above is based on the ideal calculation, and the loss caused by L_x switch and external components is not included. The actual maximum output current is between 50% and 80% of the calculation. Especially, when the I_{LX} is large, or V_{IN} is low, the loss of V_{IN} is generated with the on resistance of the switch. As for V_{OUT} , V_f (as much as 0.3 V) of the diode should be considered.

TIMING CHART

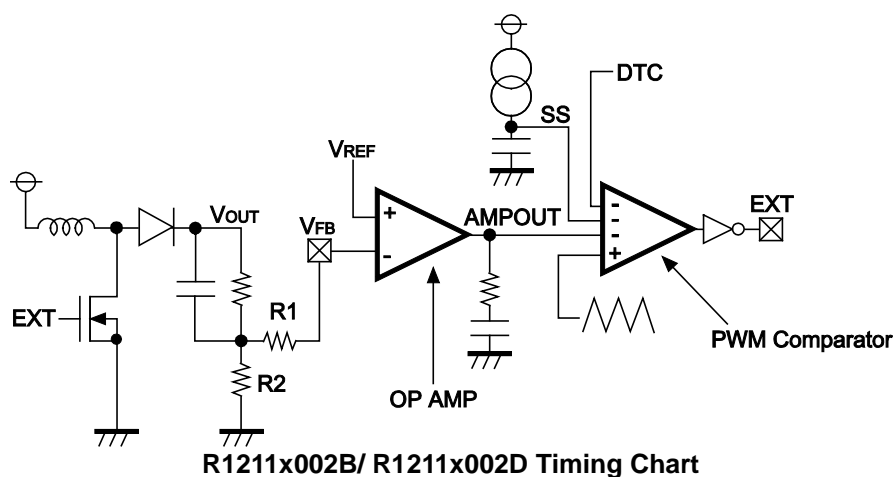
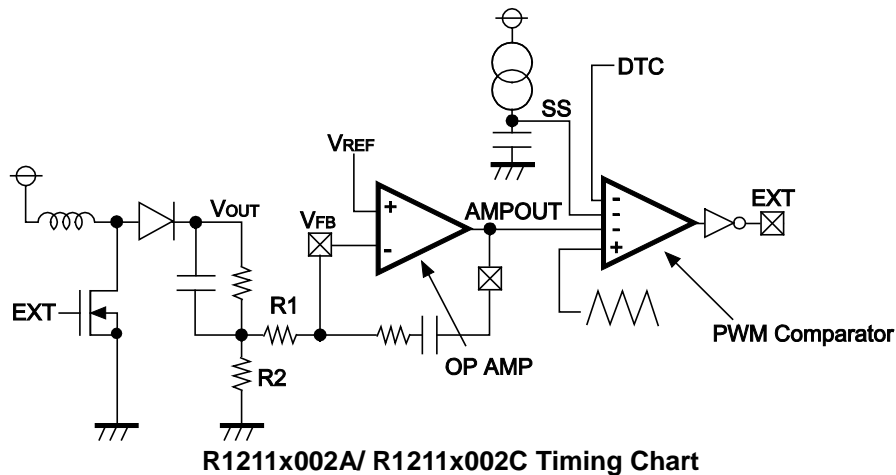

Soft-start Operation

Soft-start operation is starting from power-on as follows:

(Step1)

The voltage level of SS is rising gradually by constant current circuit of the IC and a capacitor. V_{REF} level which is input to OP AMP is also gradually rising. V_{OUT} is rising up to input voltage level just after the power-on, therefore, V_{FB} voltage is rising up to the setting voltage with input voltage and the ration of R1 and R2. AMPOUT is at "L", and switching does not start.

(Step2)

When the voltage level of SS becomes the setting voltage with the ration of R1 and R2 or more, switching operation starts. V_{REF} level gradually increases together with SS level. V_{OUT} is also rising with balancing V_{REF} and V_{FB} . Duty cycle depends on the lowest level among AMPOUT, SS, and DTC of the 4 input terminals in the PWM comparator.

(Step3)

When SS reaches 1 V, soft-start operation finishes. V_{REF} becomes constant voltage (= 1 V). Then the switching operation becomes normal mode.

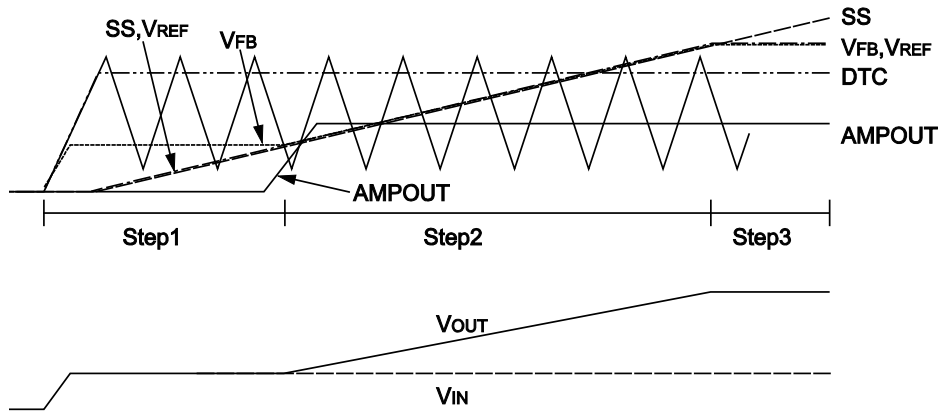
**Latch Protection Operation**

The operation of Latch protection circuit is as follows: When AMPOUT becomes "H" and the IC detects maximum duty cycle, charge to an external capacitor, C2 of DELAY pin starts. And maximum duty cycle continues and the voltage of DELAY pin reaches delay voltage detector threshold, V_{DLY} , outputs "L" to EXT pin and turns off the external power MOSFET. To release the latch protection operation, make the IC be standby mode with CE pin and make it active in terms of R1211x002B/D version. Otherwise, make supply voltage down to UVLO detector threshold or lower, and make it rise up to the normal input voltage. During the soft-start time, if the duty cycle may be the maximum, protection circuit does not work and DELAY pin is fixed at GND level. The delay time of latch protection can be calculated with C2, V_{DLY} , and Delay Pin Charge Current, I_{DLY1} , as in the next formula.

$$t = C2 \times V_{DLY} / I_{DLY1}$$

Once after the maximum duty is detected and released before delay time, charge to the capacitor is halt and delay pin outputs "L".

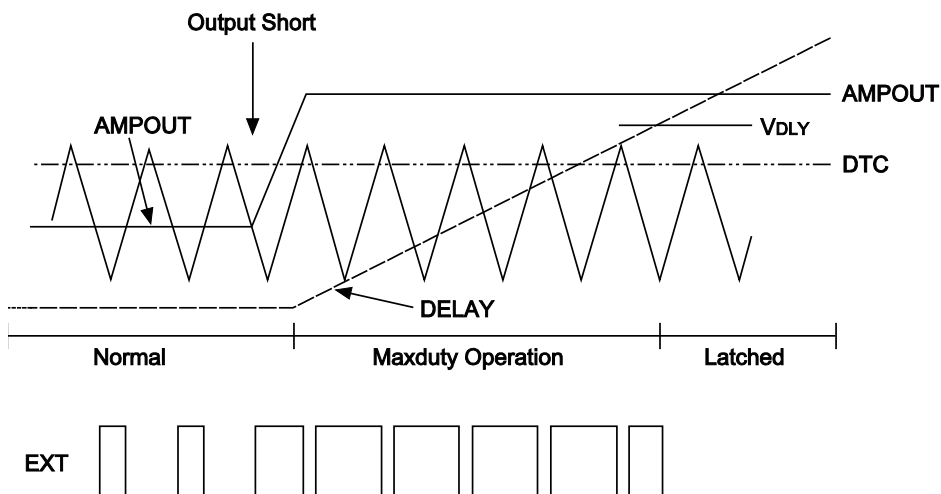

TEST CIRCUITS

R1211x002A/ R1211x002C Test Circuits

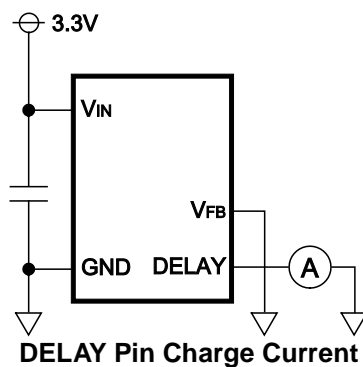
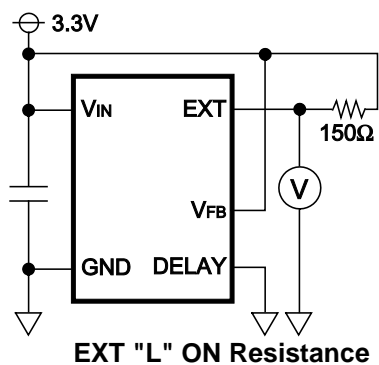
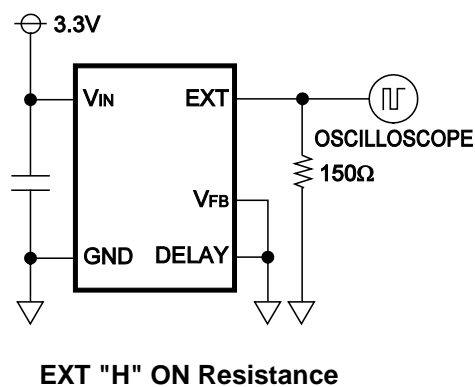
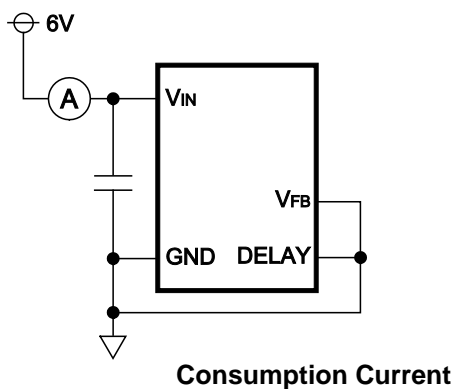
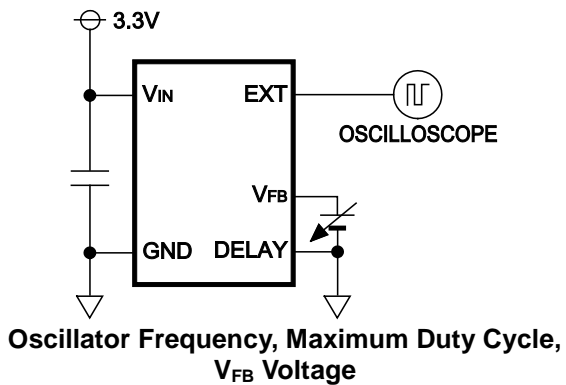

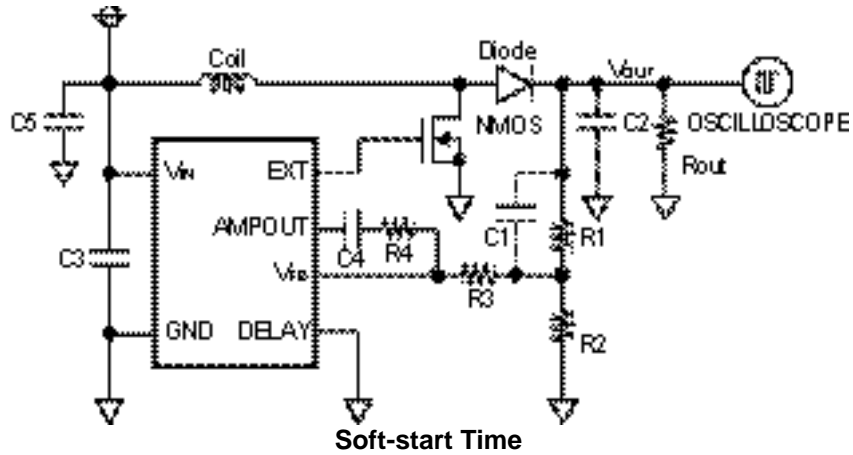
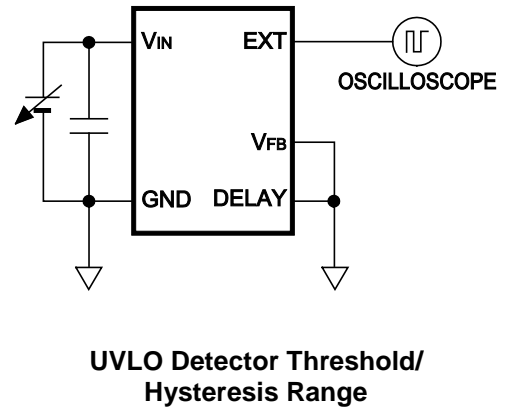
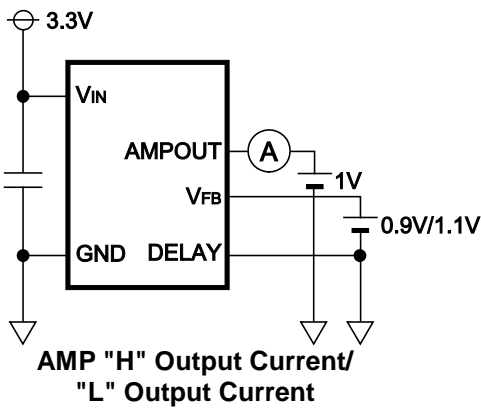
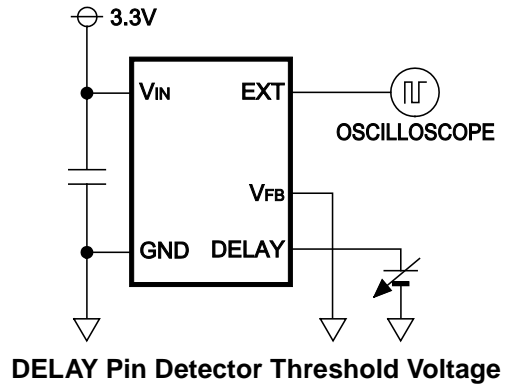
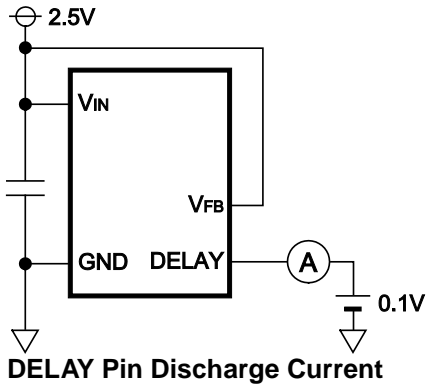

<Components>

- R1: 90 kΩ
- R2: 10 kΩ
- R3: 30 kΩ
- R4: 30 kΩ
- Rout: 1 kΩ/ 330 Ω
- Coil: VLF504012MT-220M (TDK: 22 μH)
- Diode: CRS10I30A (TOSHIBA)
- NMOS: IRF7601 (International Rectifier)

- C1: 680 pF (Ceramic)
- C2: 22 μF (Tantalum) + 2.2 μF (Ceramic)
- C3: 2.2 μF (Ceramic) + 68 μF (Tantalum)
- C4: 2200 pF (Ceramic)
- C5: 22 μF (Tantalum)

R1211x002B/ R1211x002D Test Circuits

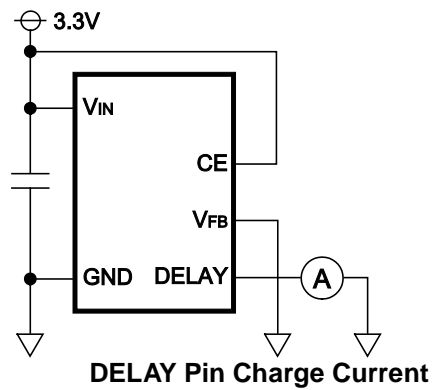
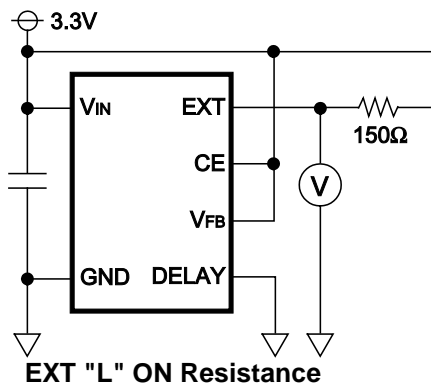
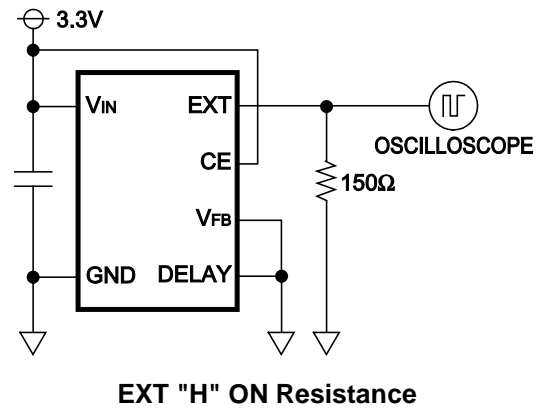
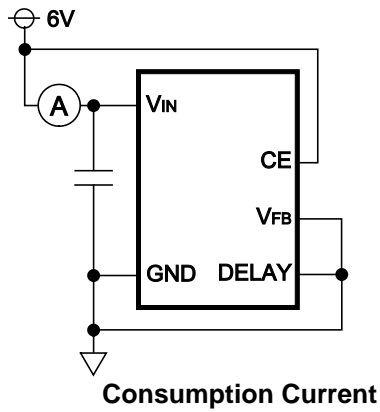
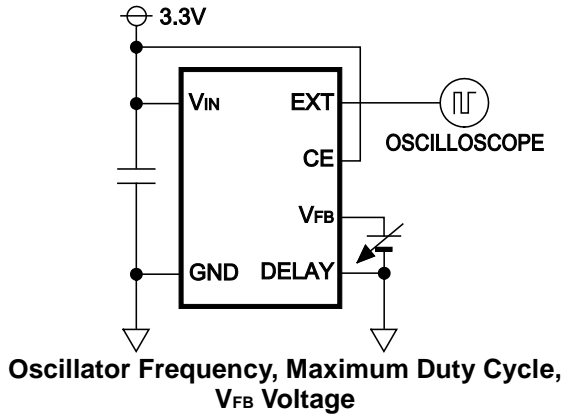

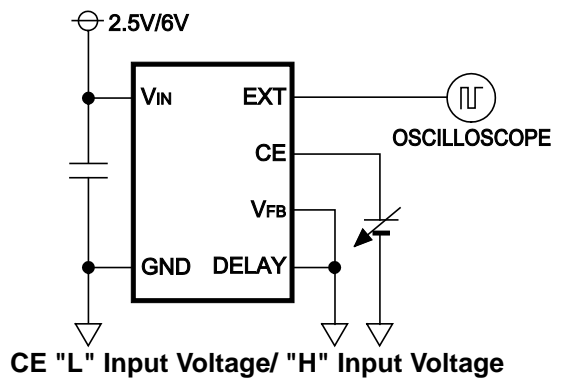
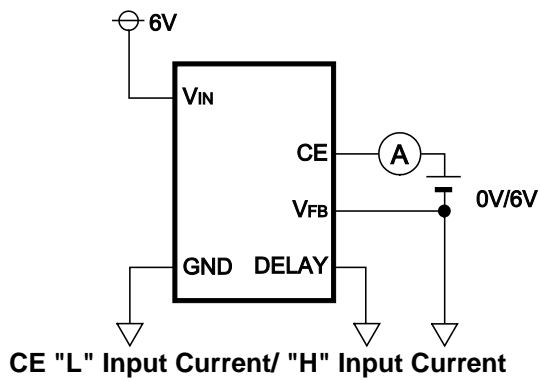
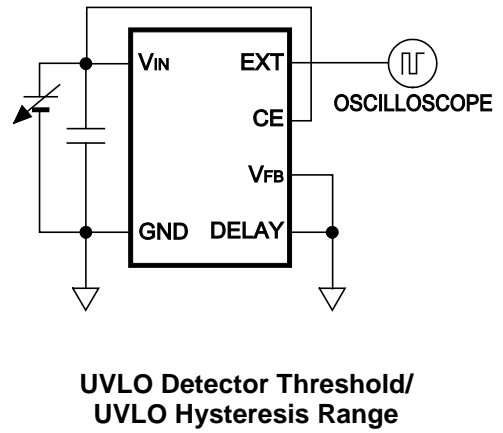
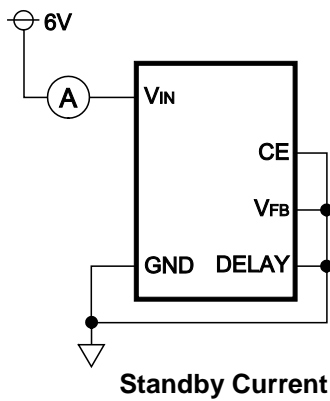
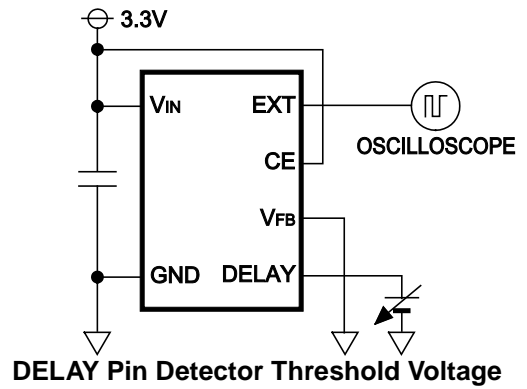
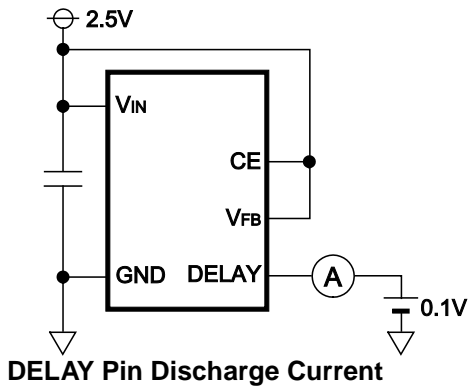

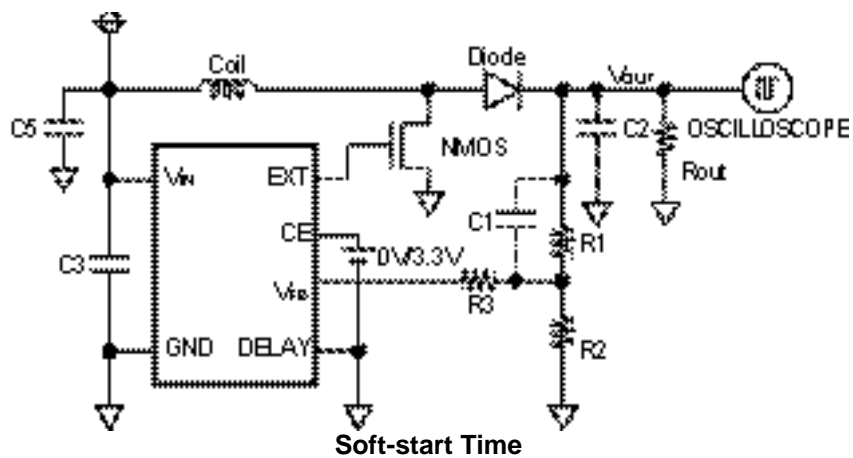

<Components>

R1: 90 k Ω R2: 10 k Ω R3: 30 k Ω Rout: 1 k Ω / 330 Ω Coil: VLF504012MT-220M (TDK: 22 μ H)

Diode: CRS10I30A (TOSHIBA)

NMOS: IRF7601 (International Rectifier)

C1: 680 pF (Ceramic)

C2: 22 μ F (Tantalum) + 2.2 μ F (Ceramic)C3: 2.2 μ F (Ceramic) + 68 μ F (Tantalum)C5: 22 μ F (Tantalum)

TYPICAL CHARACTERISTICS

1) Output Voltage vs. Output Current

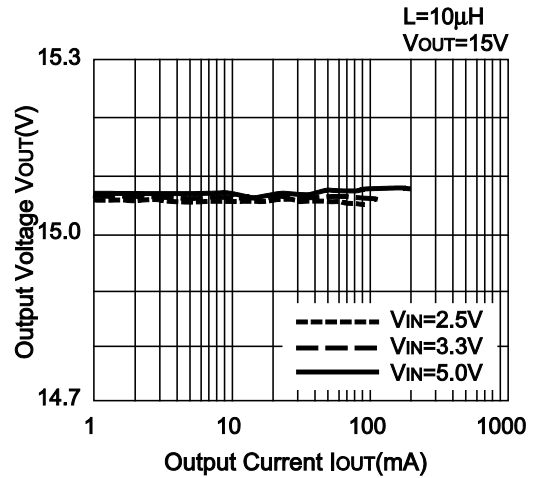
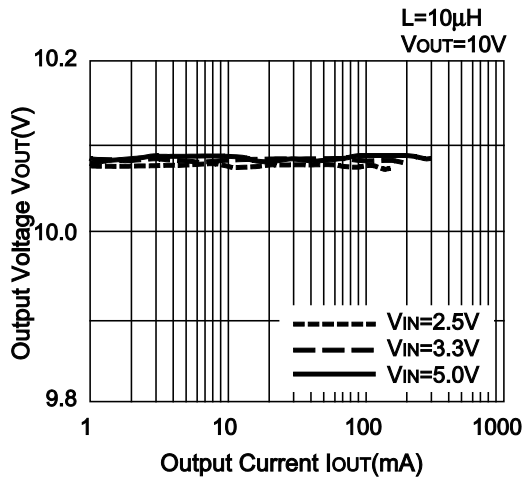
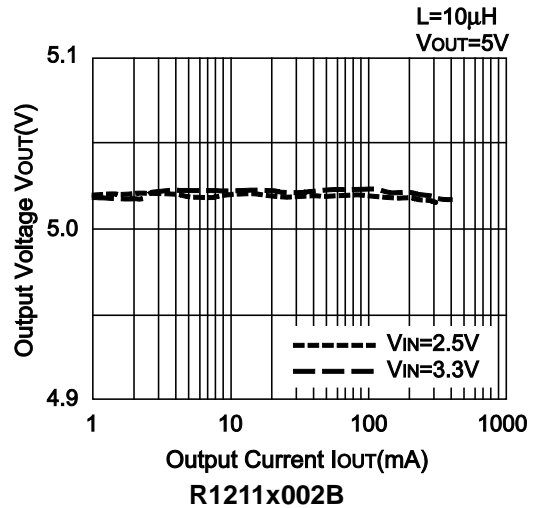
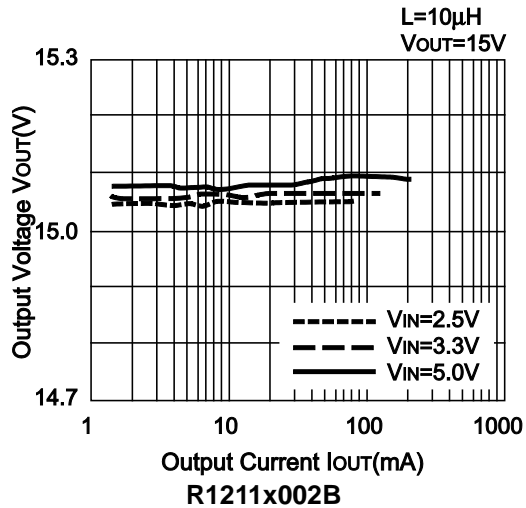
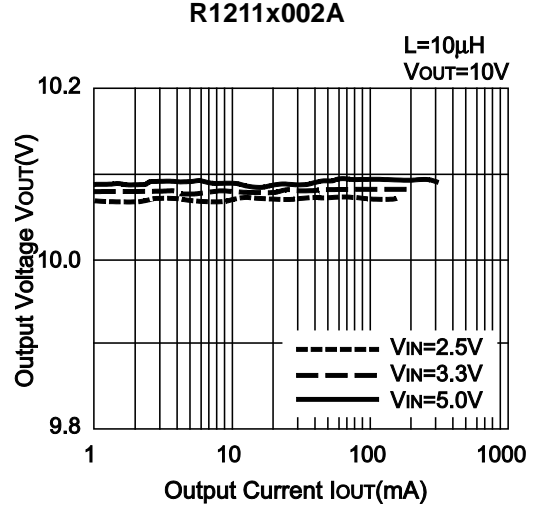
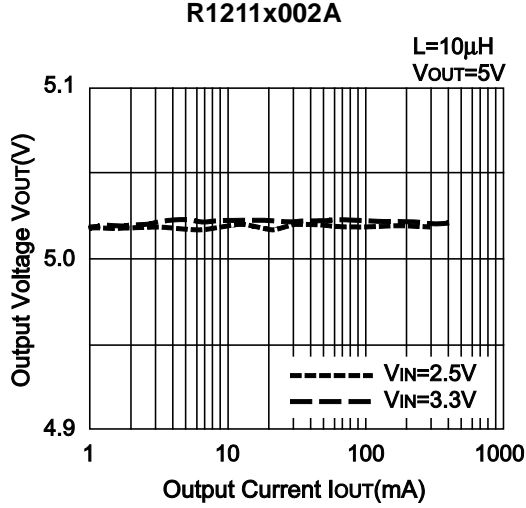

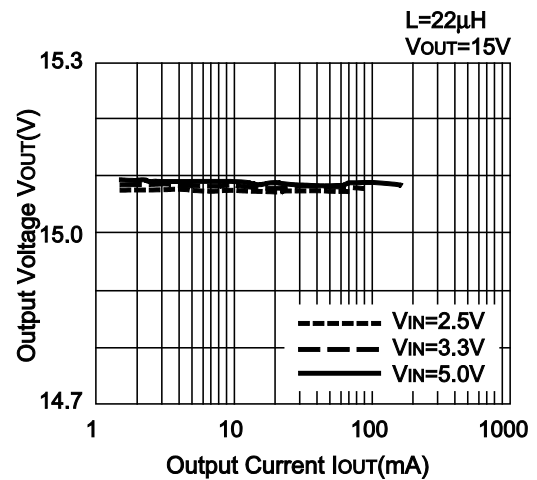
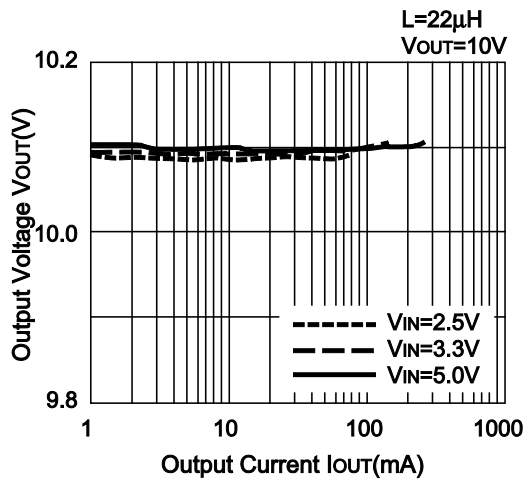
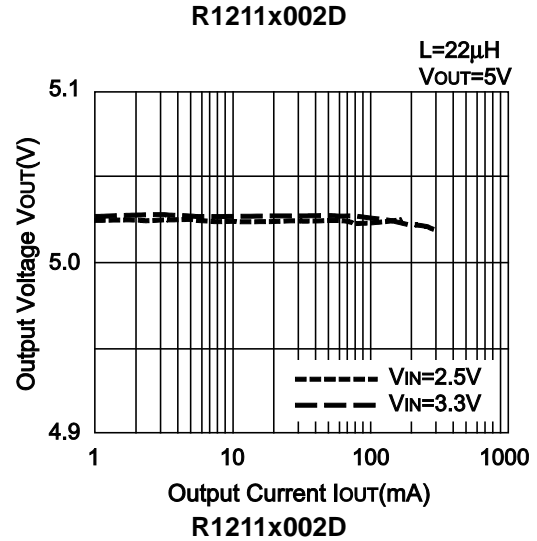
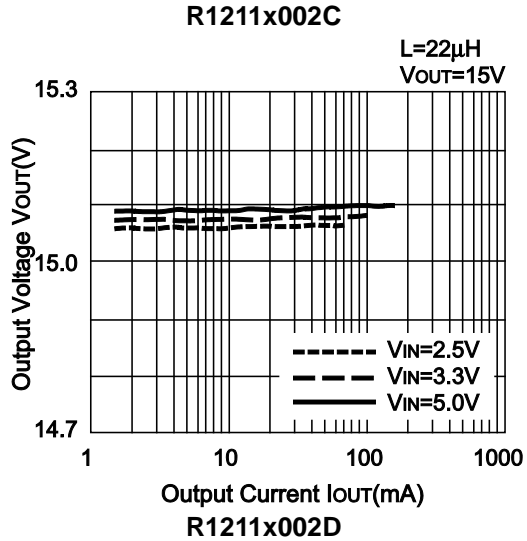
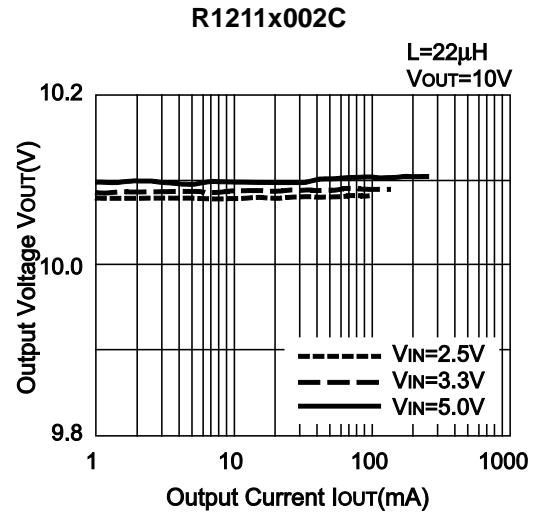
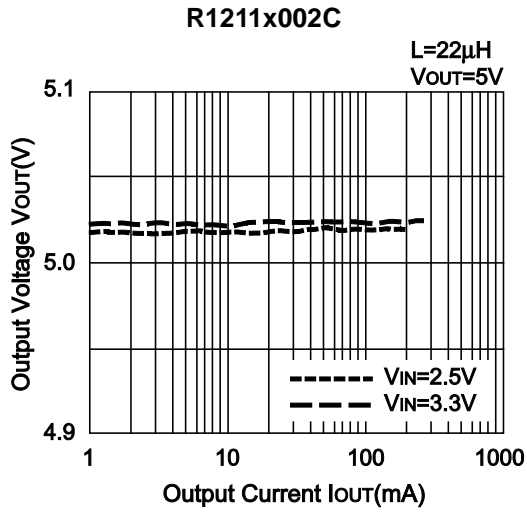

2) Efficiency vs. Output Current

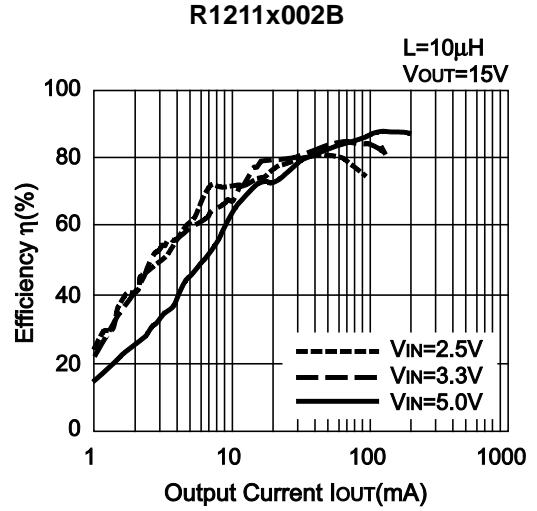
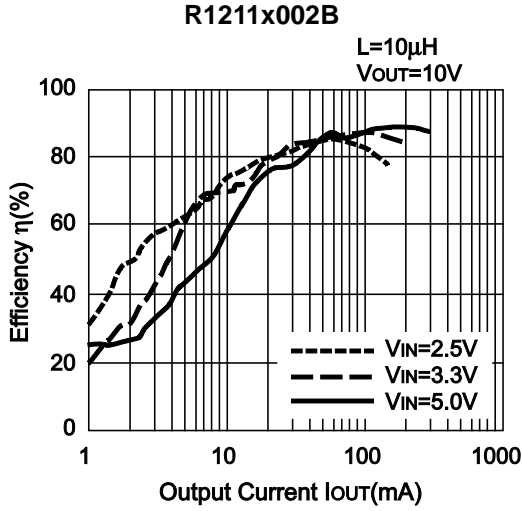
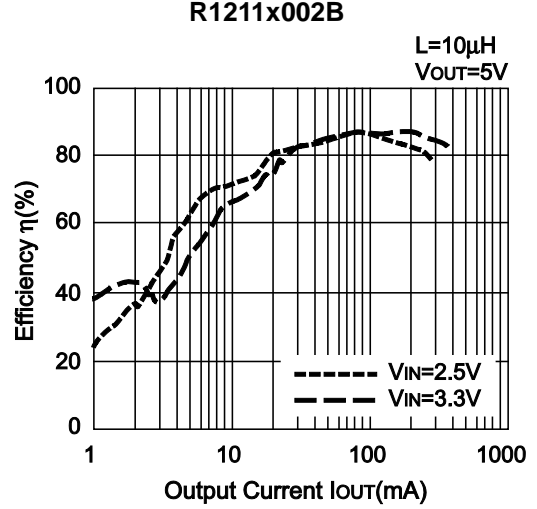
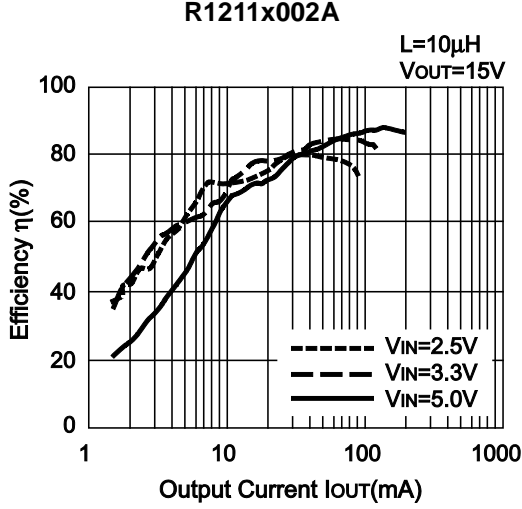
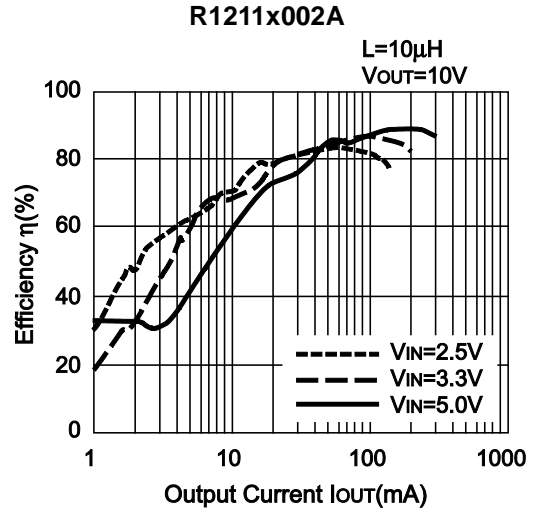
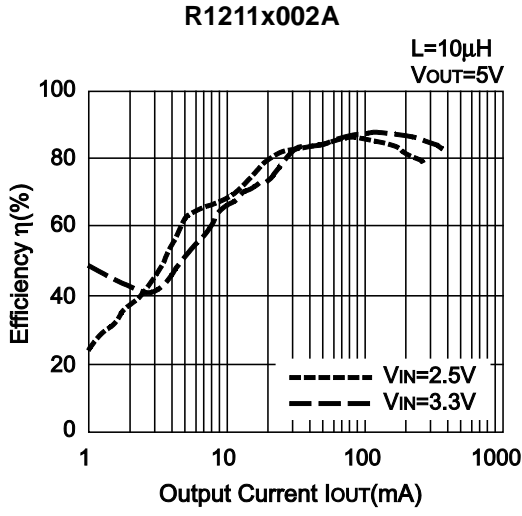

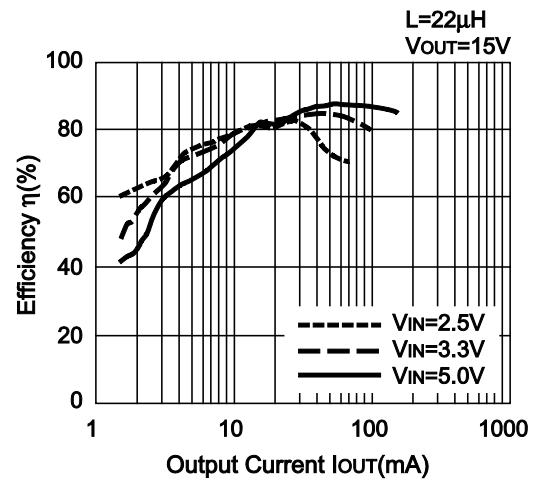
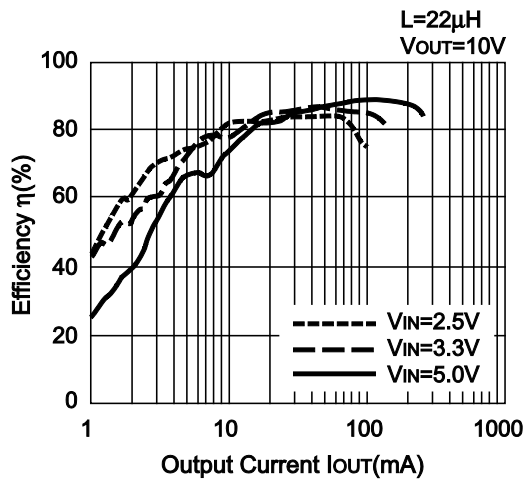
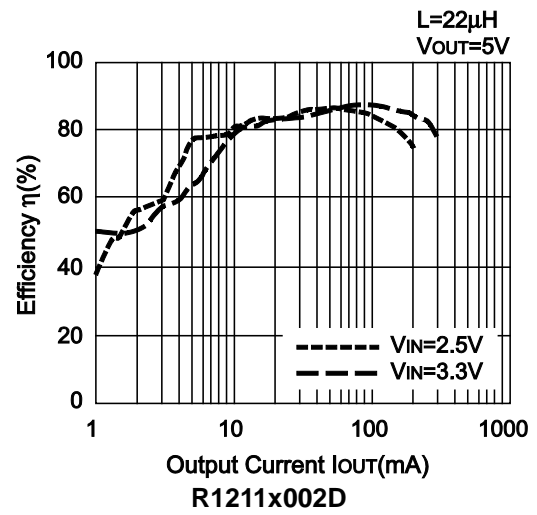
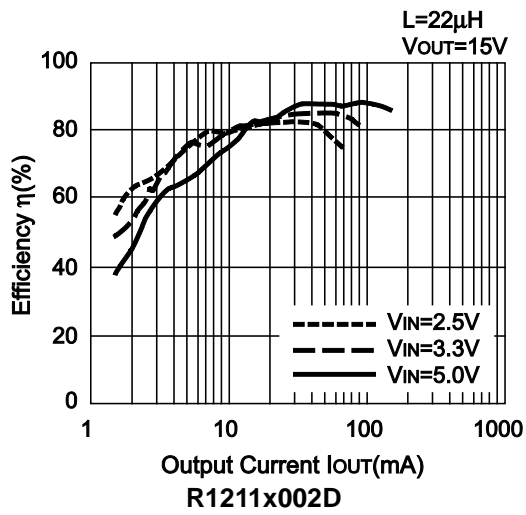
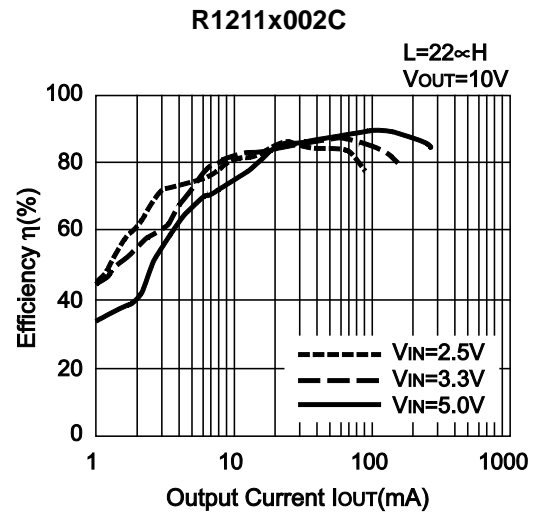
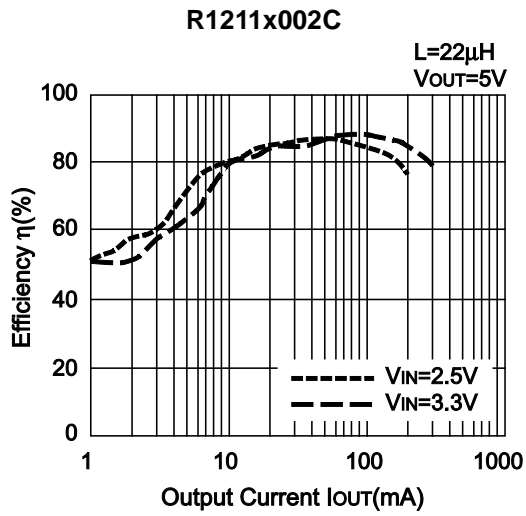

R1211x

NO.EA-088-160113

3) VFB Voltage vs. Input Voltage R1211x002x

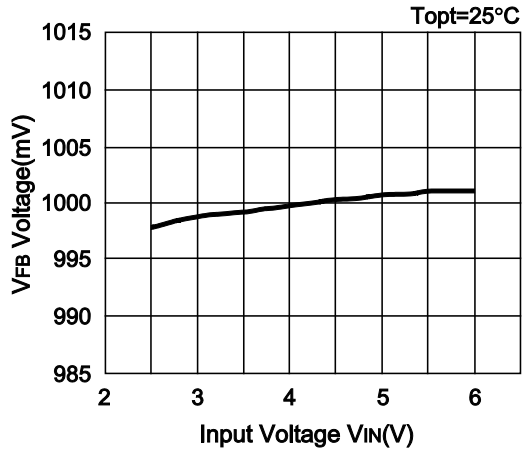

4) Oscillator Frequency vs. Input Voltage R1211x002A/B

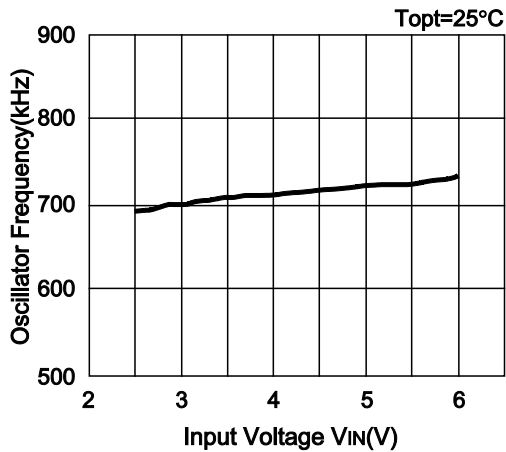

R1211x002C/D

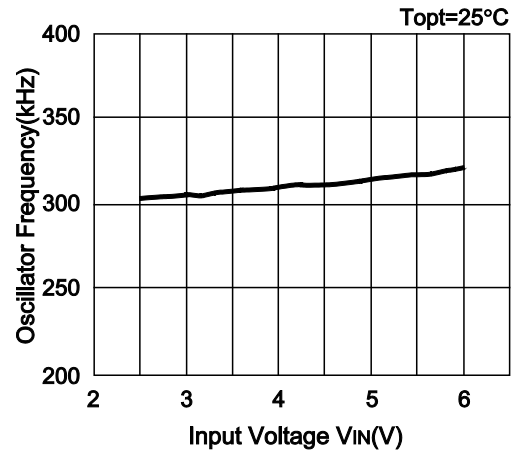

5) Supply Current vs. Input Voltage R1211x002A

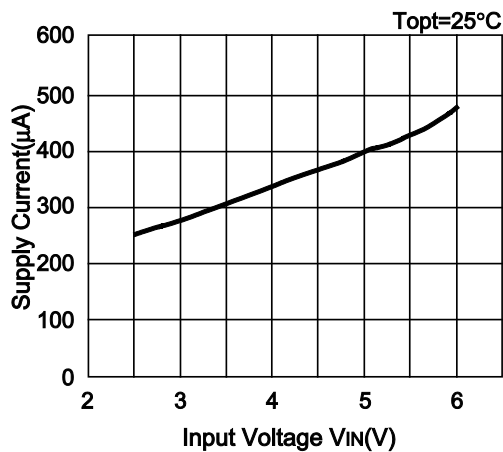

R1211x002B

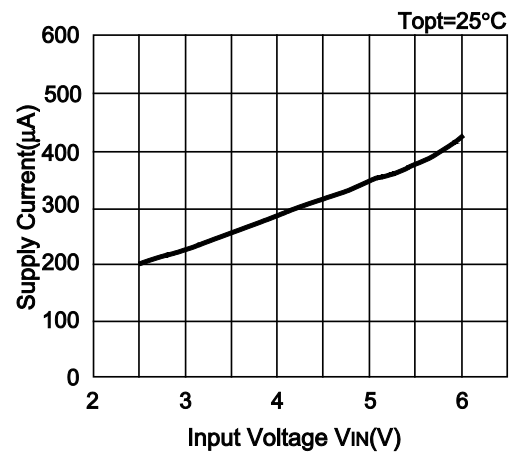

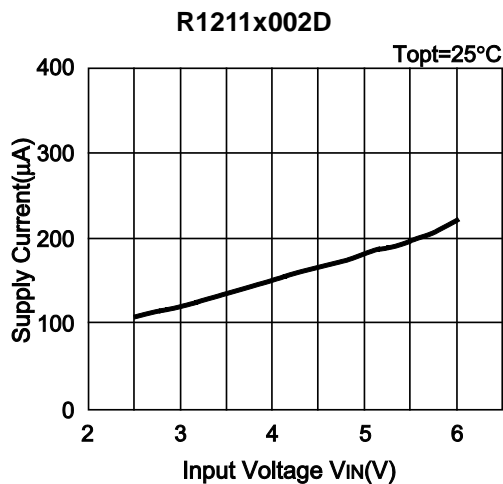
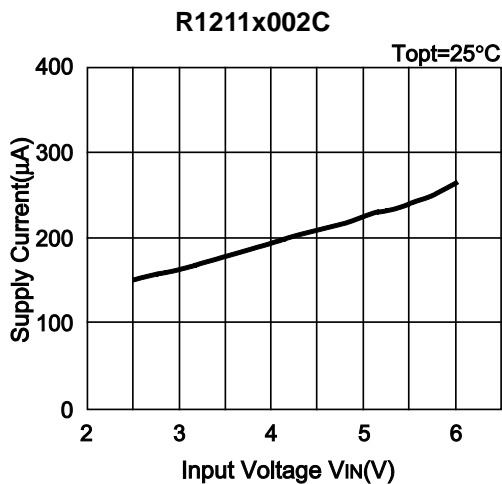

6) Maximum Duty Cycle vs. Input Voltage
R1211x002A/B

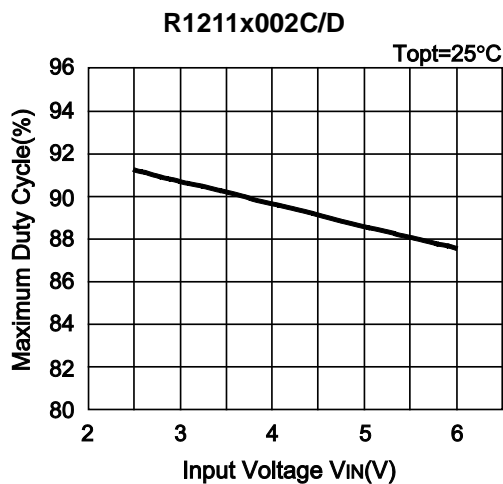
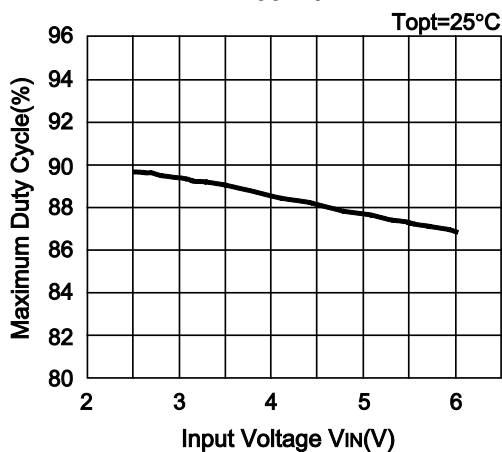

7) VFB Voltage vs. Temperature
R1211x002x

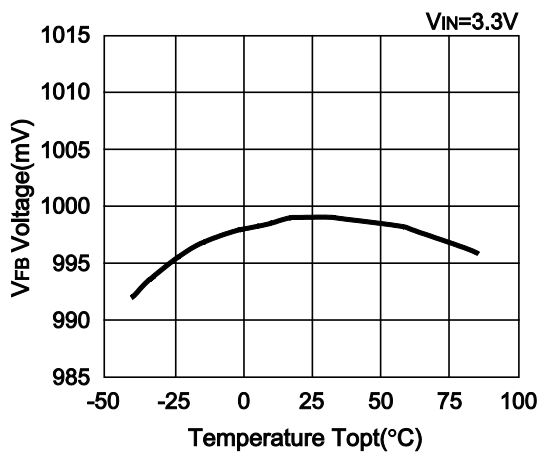

R1211x

NO.EA-088-160113

8) Oscillator Frequency vs. Temperature

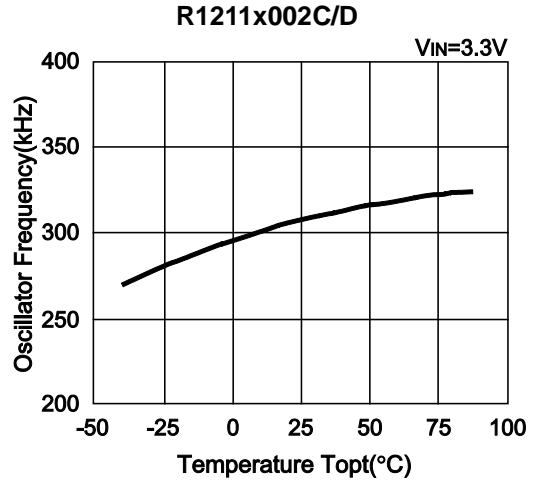
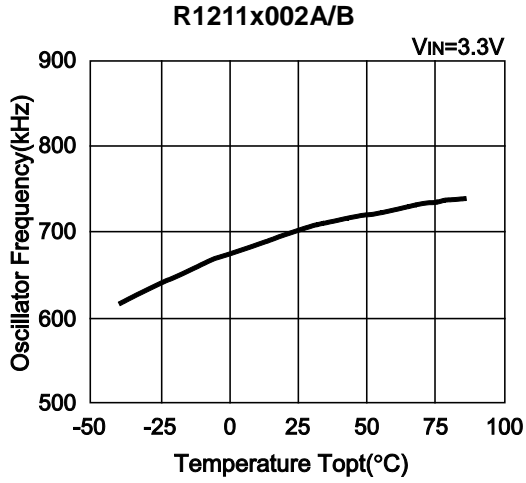

9) Supply Current vs. Temperature

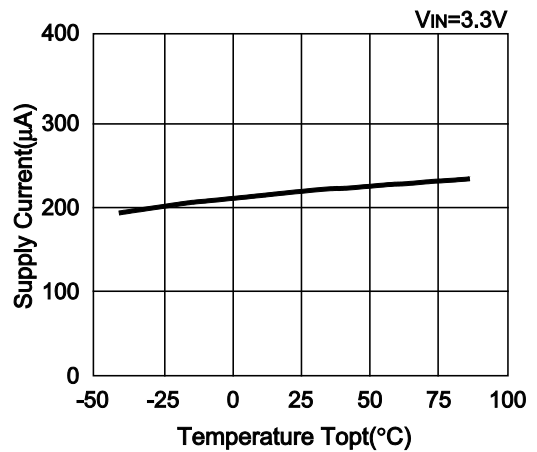
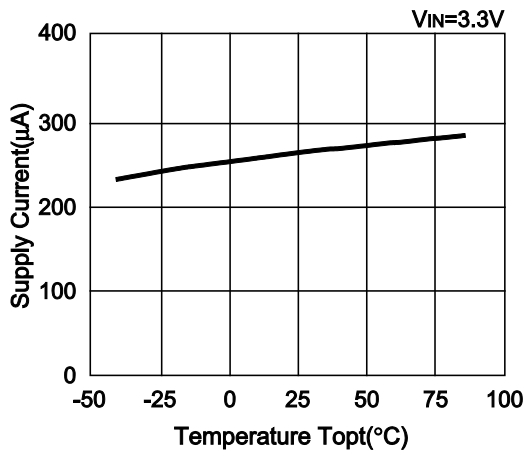
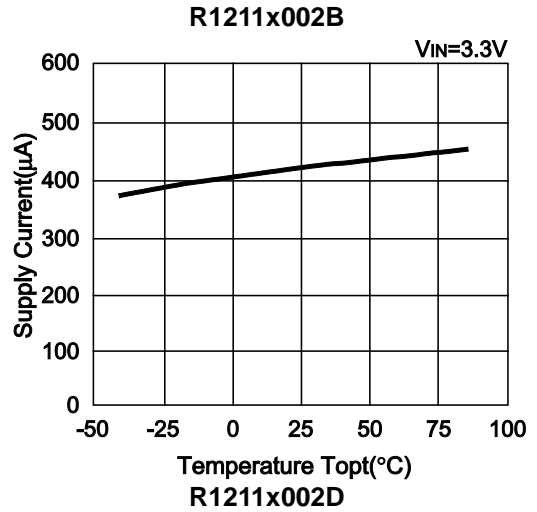
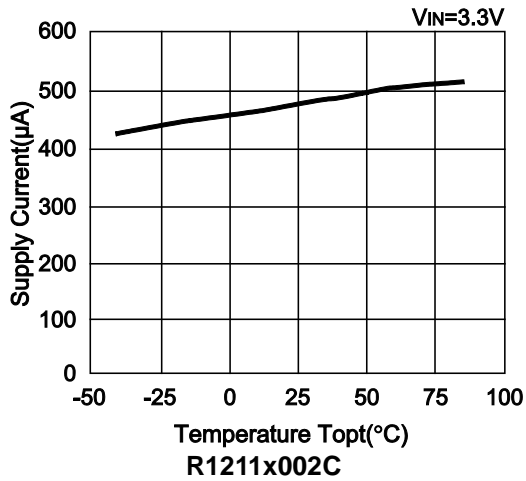

10) Maximum Duty Cycle vs. Temperature
R1211x002A/B

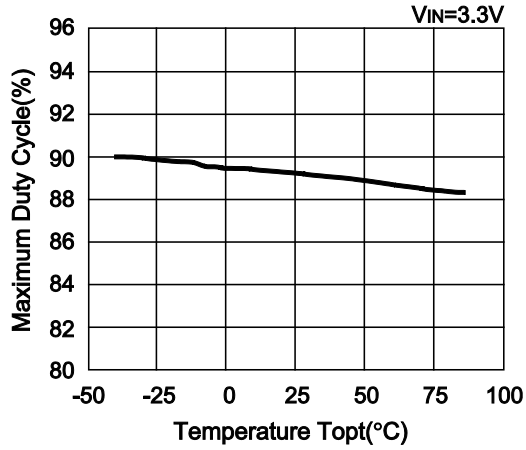

R1211x002C/D

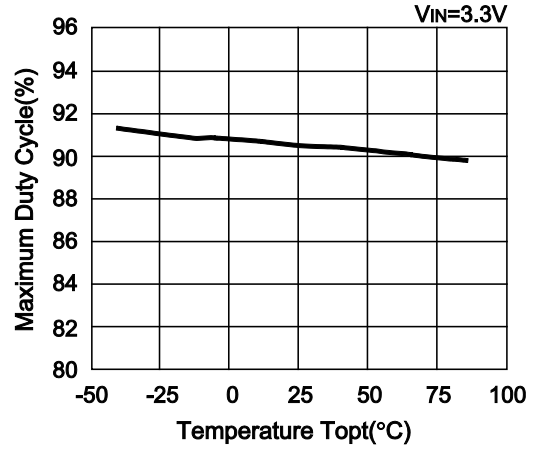

11) EXT "H" On Resistance vs. Temperature
R1211x002x

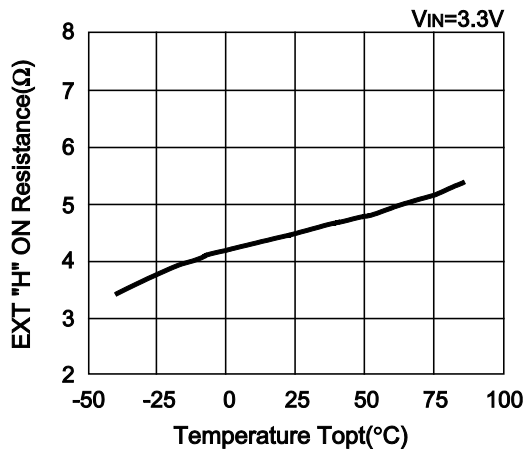

12) EXT "L" On Resistance vs. Temperature
R1211x002x

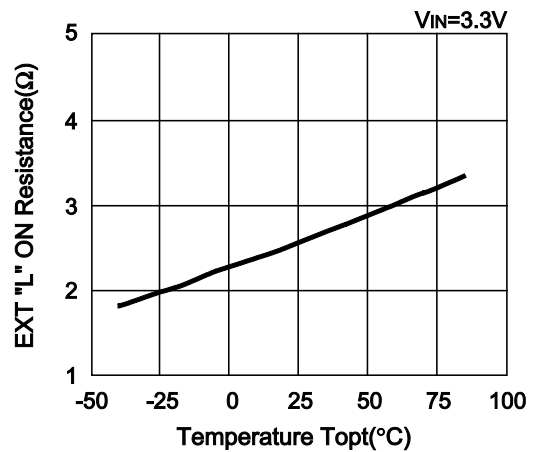

13) Soft-start Time vs. Temperature
R1211x002A/B

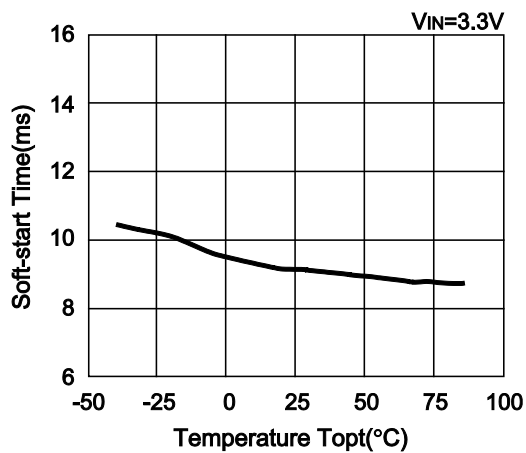

R1211x002C/D

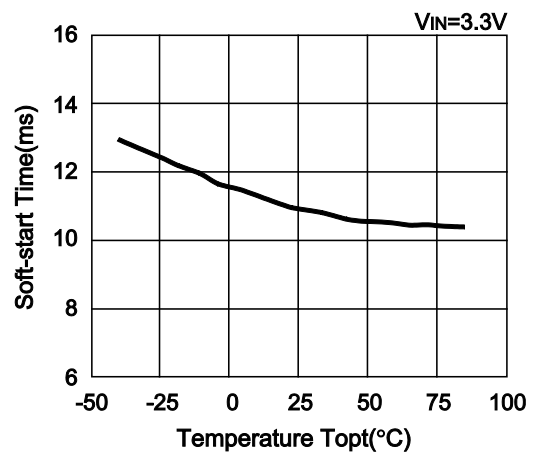

R1211x

NO.EA-088-160113

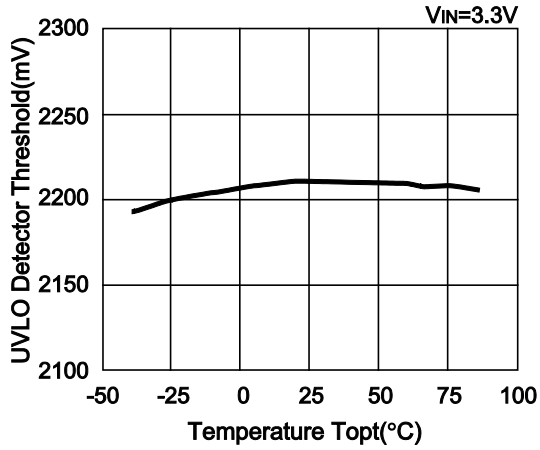
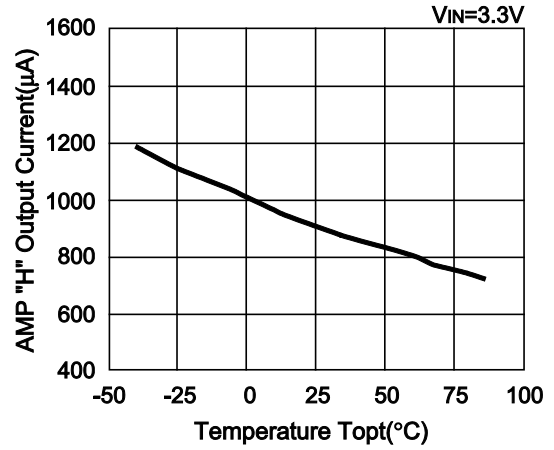
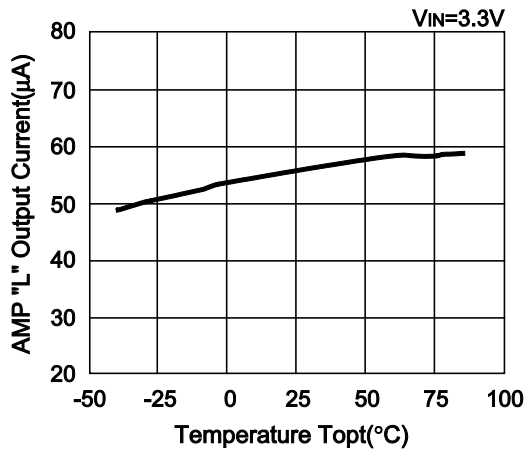
14) UVLO Detector Threshold vs. Temperature
R1211x002x**15) AMP "H" Output Current vs. Temperature**
R1211x002A/C**16) AMP "L" Output Current vs. Temperature**
R1211x002A

R1211x002C

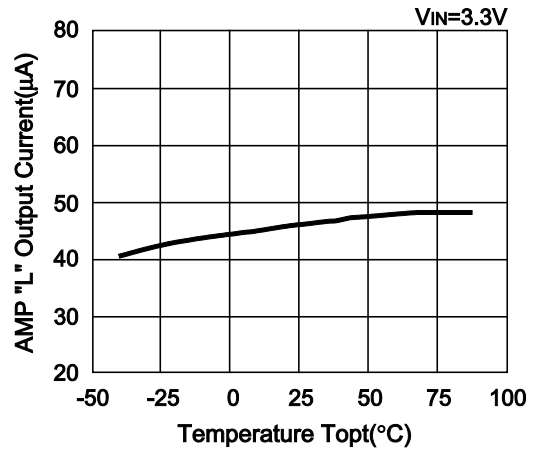
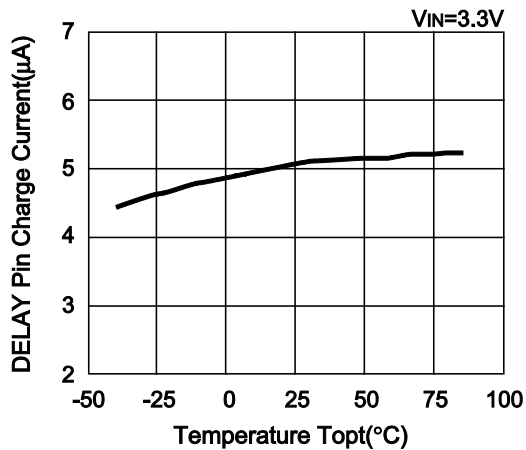
**17) DELAY Pin Charge Current vs. Temperature**
R1211x002A/B

R1211x002C/D

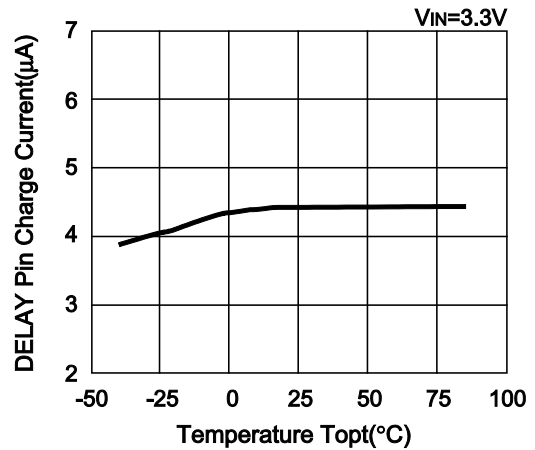

18) DELAY Pin Detector Threshold vs. Temperature R1211x002x
 19) DELAY Pin Discharge Current vs. Temperature R1211x002x

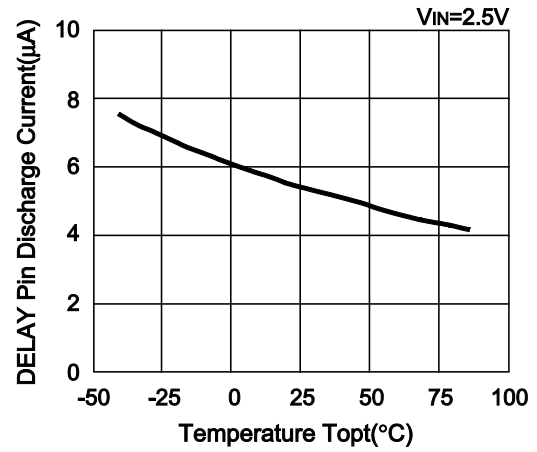
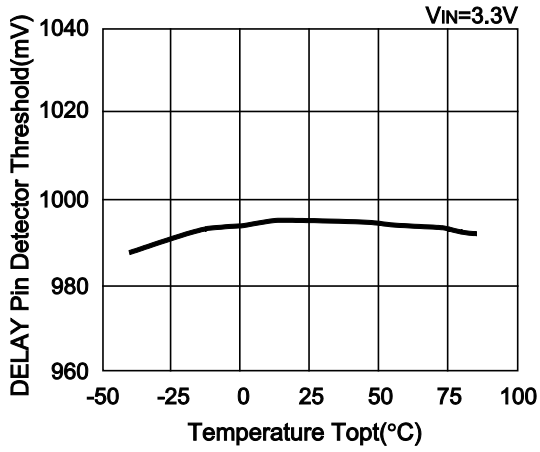

20) CE "L" Input Voltage vs. Temperature R1211x002B/D

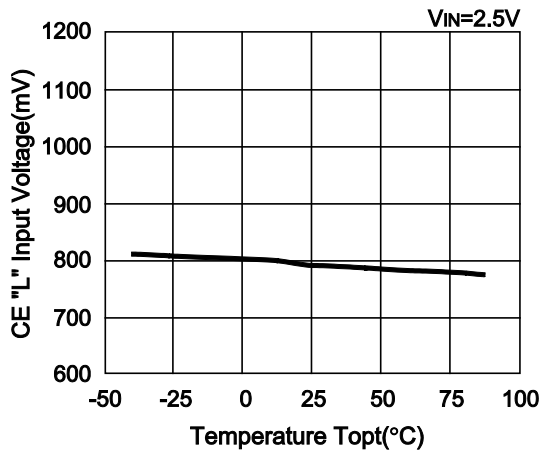

21) CE "H" Input Voltage vs. Temperature R1211x002B/D

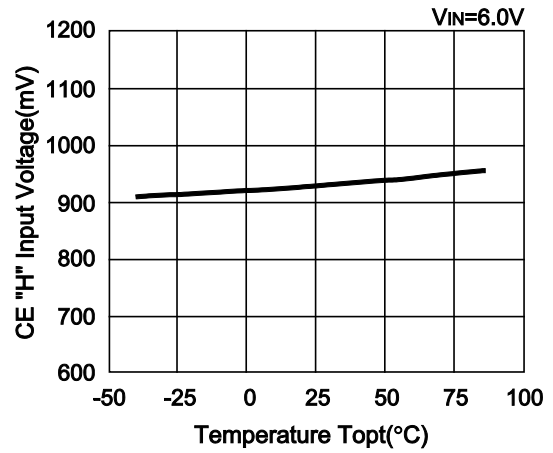

22) Standby Current vs. Temperature R1211x002B/D

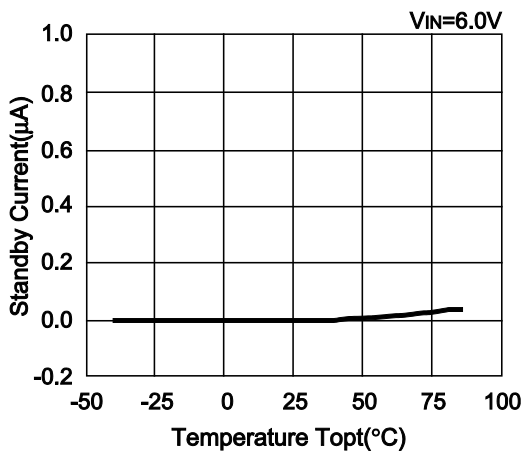

23) Load Transient Response

R1211x002A

L=10 μ H
VIN=3.3V, C3=22 μ F
VOUT=5V, IOUT=1-100mA

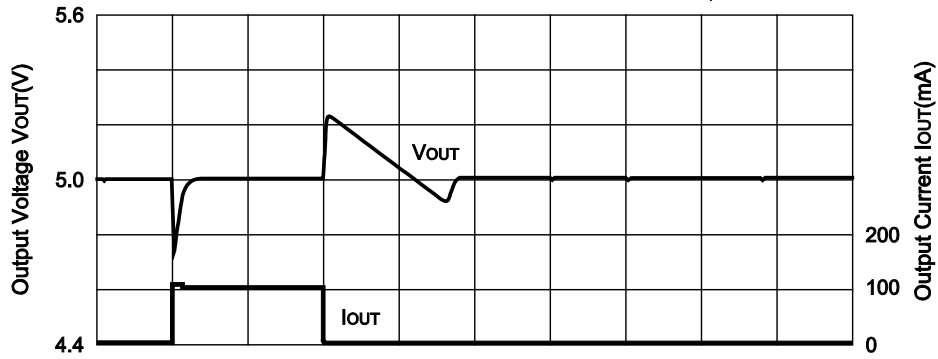

R1211x002A

L=10 μ H
VIN=3.3V, C3=22 μ F
VOUT=15V, IOUT=1-50mA

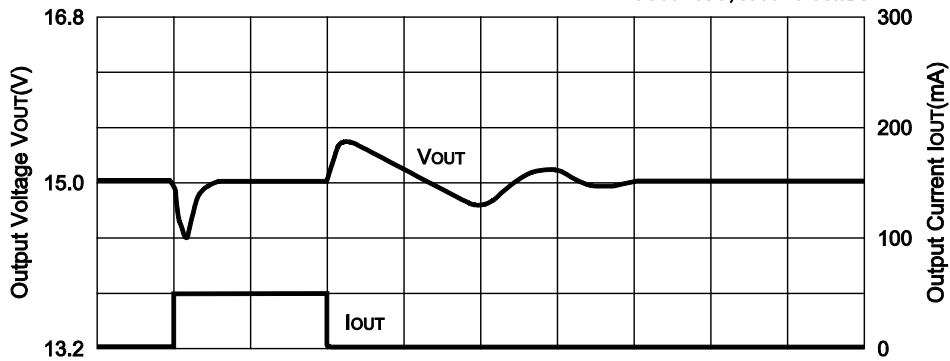

R1211x002B

L=10 μ H
VIN=3.3V, C3=22 μ F
VOUT=5V, IOUT=1-100mA

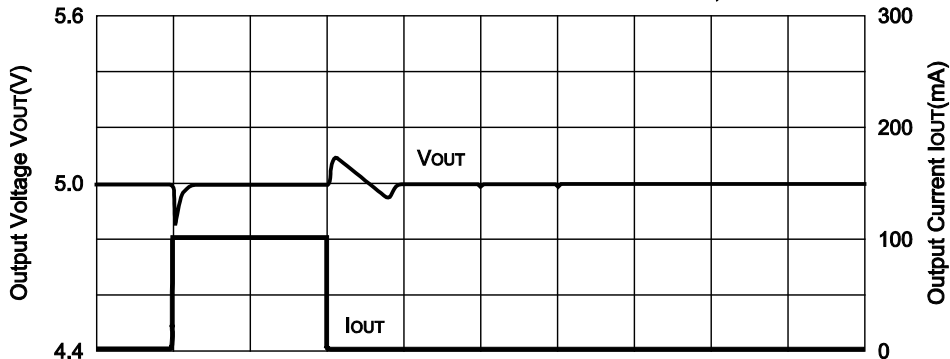

R1211x002B

L=10 μ H
VIN=3.3V, C3=22 μ F
VOUT=10V, IOUT=1-100mA

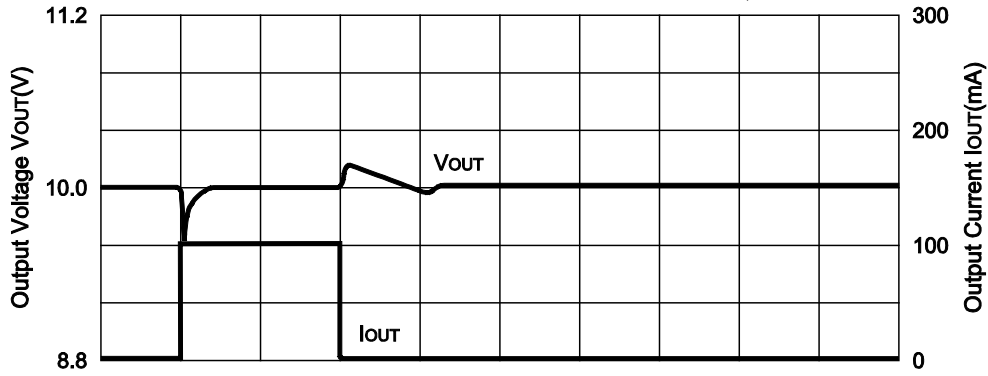

R1211x002B

L=10 μ H
VIN=3.3V, C3=22 μ F
VOUT=15V, IOUT=1-50mA

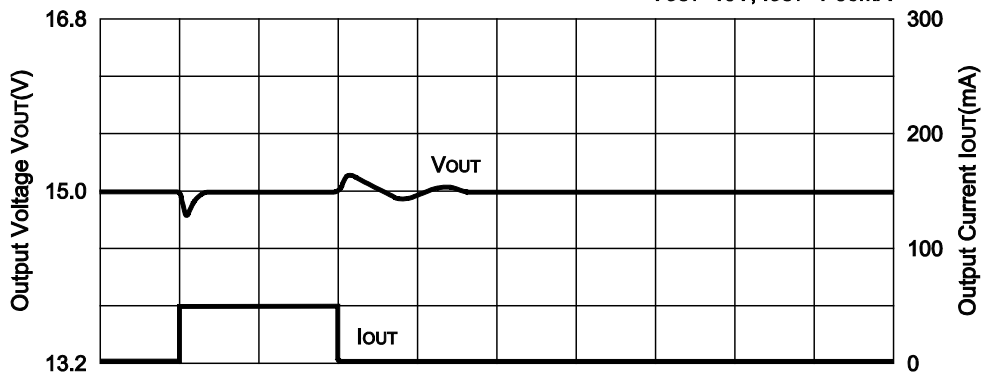

R1211x002C

L=22 μ H
VIN=3.3V, C3=22 μ F
VOUT=5V, IOUT=1-100mA

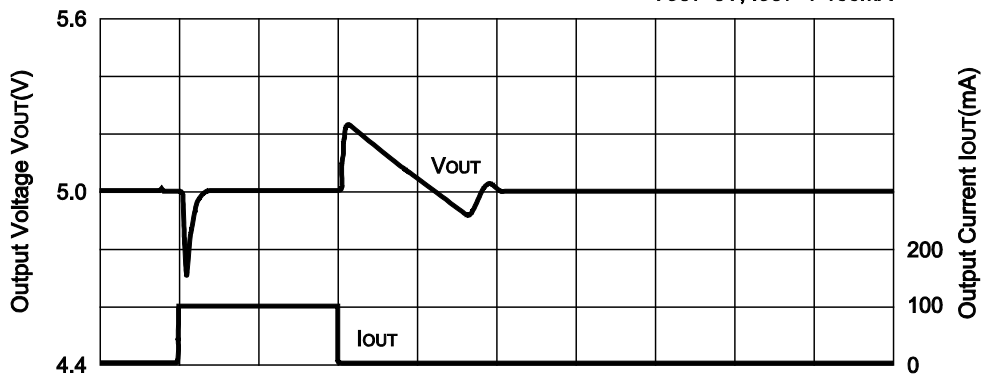

Time (5ms/div)

R1211x002C

L=22 μ H
VIN=3.3V, C3=22 μ F
VOUT=10V, IOUT=1-100mA

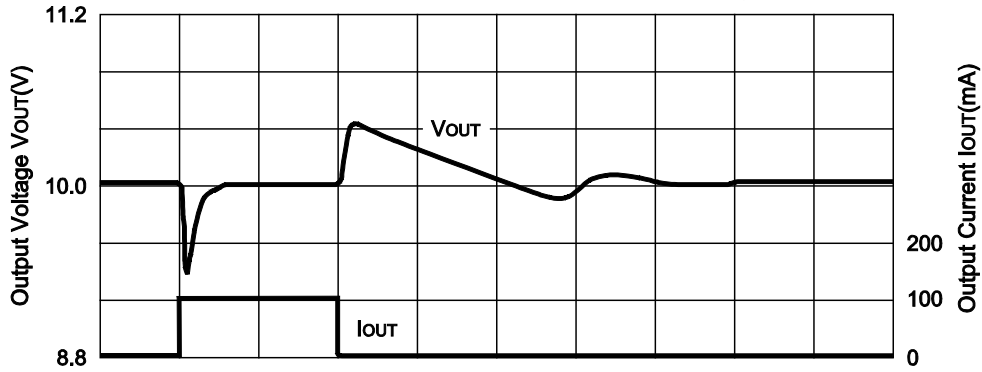

Time (5ms/div)

R1211x002C

L=22 μ H
VIN=3.3V, C3=22 μ F
VOUT=15V, IOUT=1-50mA

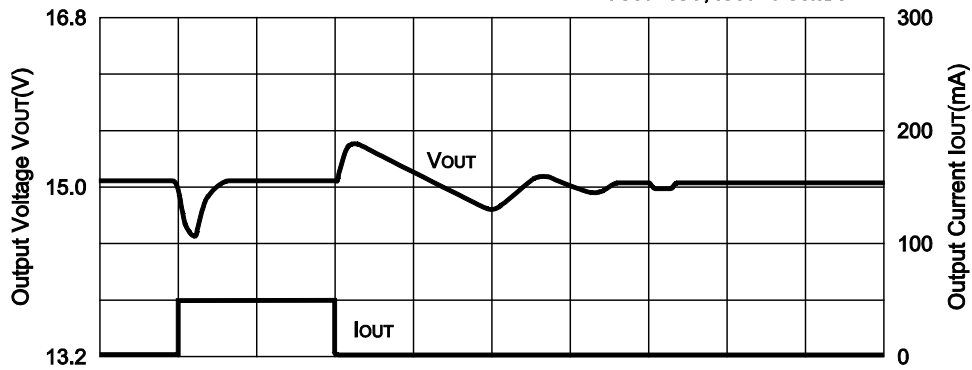

Time (5ms/div)

R1211x002D

L=22 μ H
VIN=3.3V, C3=22 μ F
VOUT=5V, IOUT=1-100mA

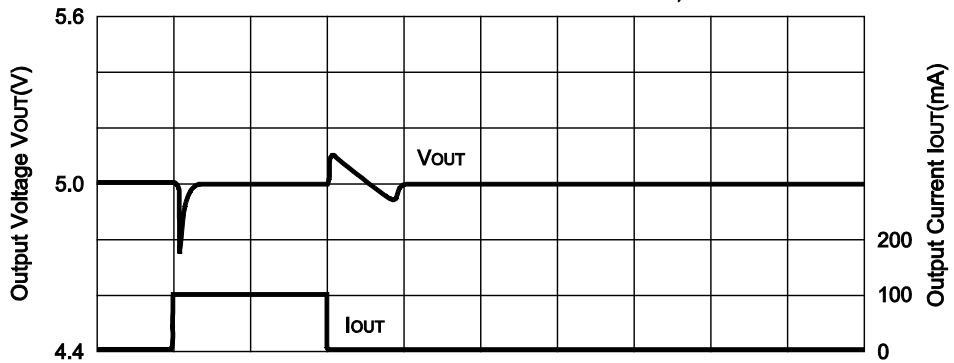

Time (5ms/div)

R1211x002D

L=22 μ H
 VIN=3.3V, C3=22 μ F
 VOUT=10V, IOUT=1-100mA

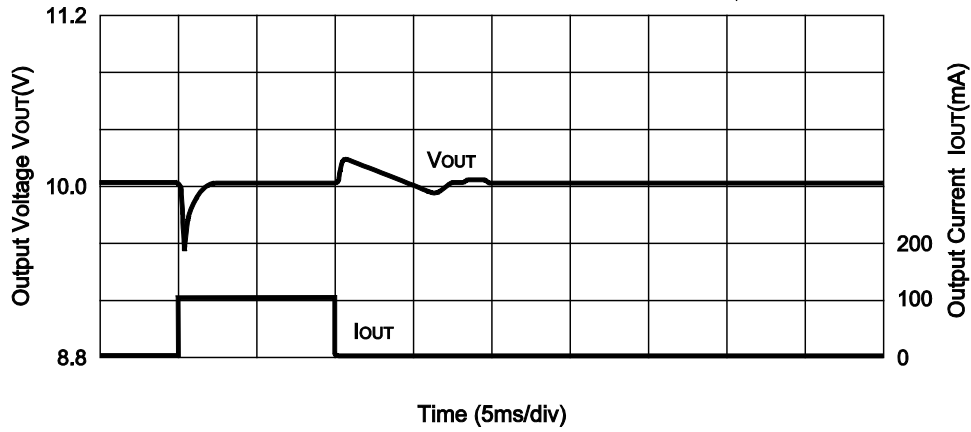

Time (5ms/div)

R1211x002D

L=22 μ H
 VIN=3.3V, C3=22 μ F
 VOUT=15V, IOUT=1-50mA

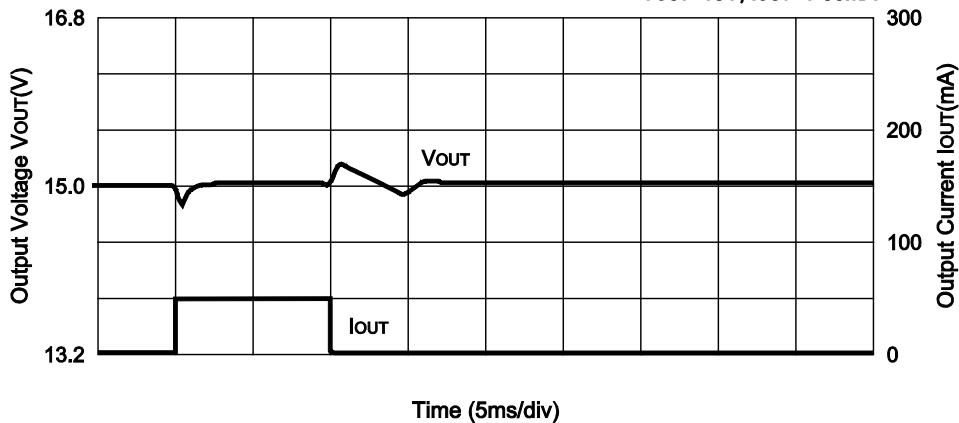

Time (5ms/div)

24) Power-on Response

R1211x002A

L=10 μ H
 VIN=3.3V, IOUT=10mA

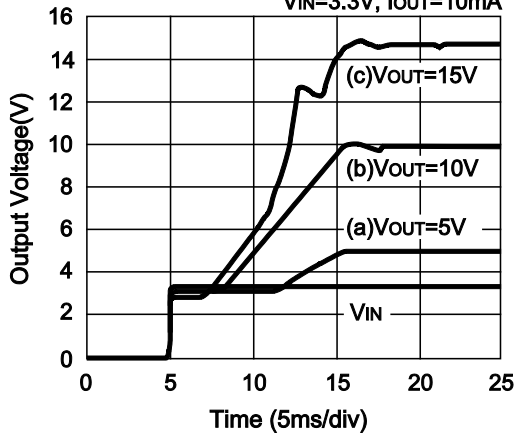

R1211x002B

L=10 μ H
 VIN=3.3V, IOUT=10mA

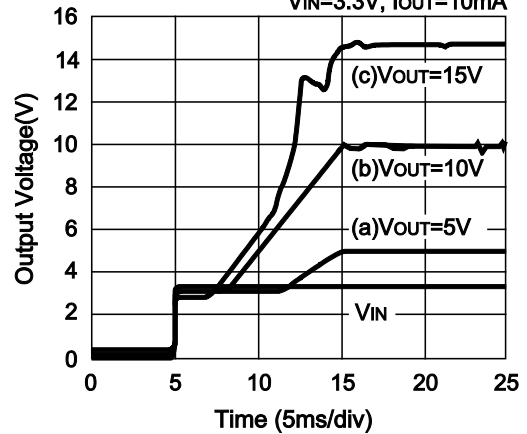

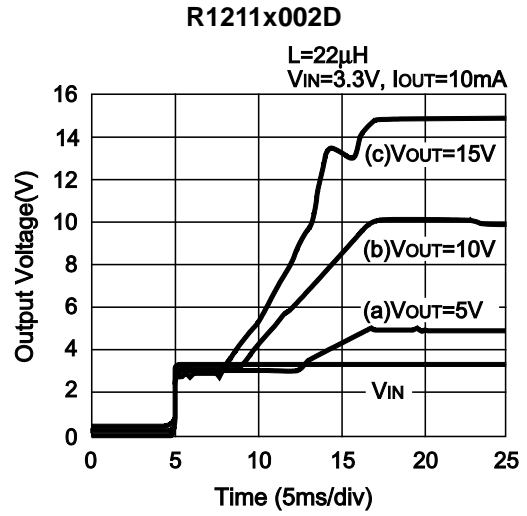
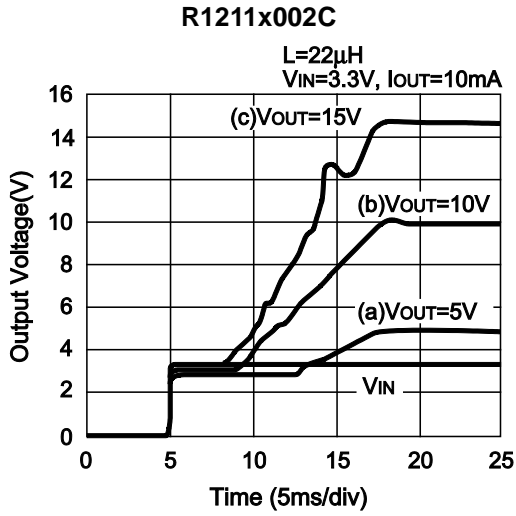

25) Turn-on speed with CE pin

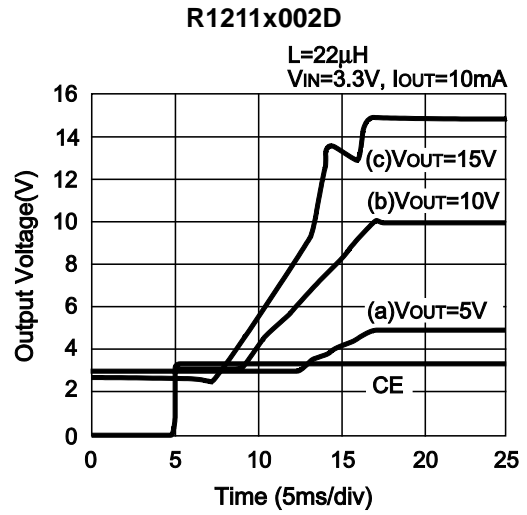
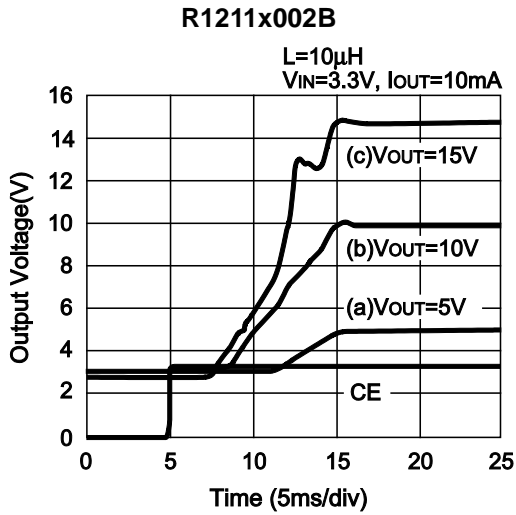



1. The products and the product specifications described in this document are subject to change or discontinuation of production without notice for reasons such as improvement. Therefore, before deciding to use the products, please refer to Ricoh sales representatives for the latest information thereon.
2. The materials in this document may not be copied or otherwise reproduced in whole or in part without prior written consent of Ricoh.
3. Please be sure to take any necessary formalities under relevant laws or regulations before exporting or otherwise taking out of your country the products or the technical information described herein.
4. The technical information described in this document shows typical characteristics of and example application circuits for the products. The release of such information is not to be construed as a warranty of or a grant of license under Ricoh's or any third party's intellectual property rights or any other rights.
5. The products listed in this document are intended and designed for use as general electronic components in standard applications (office equipment, telecommunication equipment, measuring instruments, consumer electronic products, amusement equipment etc.). Those customers intending to use a product in an application requiring extreme quality and reliability, for example, in a highly specific application where the failure or misoperation of the product could result in human injury or death (aircraft, spacevehicle, nuclear reactor control system, traffic control system, automotive and transportation equipment, combustion equipment, safety devices, life support system etc.) should first contact us.
6. We are making our continuous effort to improve the quality and reliability of our products, but semiconductor products are likely to fail with certain probability. In order to prevent any injury to persons or damages to property resulting from such failure, customers should be careful enough to incorporate safety measures in their design, such as redundancy feature, fire containment feature and fail-safe feature. We do not assume any liability or responsibility for any loss or damage arising from misuse or inappropriate use of the products.
7. Anti-radiation design is not implemented in the products described in this document.
8. The X-ray exposure can influence functions and characteristics of the products. Confirm the product functions and characteristics in the evaluation stage.
9. WLCSP products should be used in light shielded environments. The light exposure can influence functions and characteristics of the products under operation or storage.
10. There can be variation in the marking when different AOI (Automated Optical Inspection) equipment is used. In the case of recognizing the marking characteristic with AOI, please contact Ricoh sales or our distributor before attempting to use AOI.
11. Please contact Ricoh sales representatives should you have any questions or comments concerning the products or the technical information.



Ricoh is committed to reducing the environmental loading materials in electrical devices with a view to contributing to the protection of human health and the environment.

Ricoh has been providing RoHS compliant products since April 1, 2006 and Halogen-free products since April 1, 2012.

RICOH RICOH ELECTRONIC DEVICES CO., LTD.

<https://www.e-devices.ricoh.co.jp/en/>

Sales & Support Offices

Ricoh Electronic Devices Co., Ltd.

Shin-Yokohama Office (International Sales)

2-3, Shin-Yokohama 3-chome, Kohoku-ku, Yokohama-shi, Kanagawa, 222-8530, Japan
Phone: +81-50-3814-7687 Fax: +81-45-474-0074

Ricoh Americas Holdings, Inc.

675 Campbell Technology Parkway, Suite 200 Campbell, CA 95008, U.S.A.
Phone: +1-408-610-3105

Ricoh Europe (Netherlands) B.V.

Semiconductor Support Centre

Prof. W.H. Keesomlaan 1, 1183 DJ Amstelveen, The Netherlands
Phone: +31-20-5474-309

Ricoh International B.V. - German Branch

Semiconductor Sales and Support Centre

Oberrather Strasse 6, 40472 Düsseldorf, Germany
Phone: +49-211-6546-0

Ricoh Electronic Devices Korea Co., Ltd.

3F, Haesung Bldg, 504, Teheran-ro, Gangnam-gu, Seoul, 135-725, Korea
Phone: +82-2-2135-5700 Fax: +82-2-2051-5713

Ricoh Electronic Devices Shanghai Co., Ltd.

Room 403, No.2 Building, No.690 Bibo Road, Pu Dong New District, Shanghai 201203,
People's Republic of China
Phone: +86-21-5027-3200 Fax: +86-21-5027-3299

Ricoh Electronic Devices Shanghai Co., Ltd.

Shenzhen Branch

1205, Block D (Jinlong Building), Kingkey 100, Hongbao Road, Luohu District,
Shenzhen, China
Phone: +86-755-8348-7600 Ext 225

Ricoh Electronic Devices Co., Ltd.

Taipei office

Room 109, 10F-1, No.51, Hengyang Rd., Taipei City, Taiwan (R.O.C.)
Phone: +886-2-2313-1621/1622 Fax: +886-2-2313-1623

Mouser Electronics

Authorized Distributor

Click to View Pricing, Inventory, Delivery & Lifecycle Information:

Ricoh Electronics:

[R1211N002B-TR-FE](#) [R1211D002D-TR-FE](#) [R1211D002B-TR-FE](#) [R1211D102A-TR-FE](#) [R1211N002A-TR-FE](#)
[R1211D002A-TR-FE](#) [R1211D103A-TR-FE](#) [R1211D104A-TR-FE](#) [R1211N002C-TR-FE](#) [R1211N002D-TR-FE](#)
[R1211D002C-TR-FE](#) [R1211D100A-TR-FE](#) [R1211D101A-TR-FE](#) [R1211D102C-TR-FE](#)