

ADSP-SC582/SC583/SC584/SC587/SC589/ADSP-21583/21584/21587

SYSTEM FEATURES

- Dual enhanced SHARC+ high performance floating-point cores
 - Up to 500 MHz per SHARC+ core
 - Up to 5 Mb (640 kB) Level 1 (L1) SRAM memory per core with parity (optional ability to configure as cache)
 - 32-bit, 40-bit, and 64-bit floating-point support
 - 32-bit fixed point
 - Byte, short-word, word, long-word addressed
- Arm Cortex-A5 core
 - 500 MHz/800 DMIPS with NEON/VFPv4-D16/Jazelle
 - 32 kB L1 instruction cache/32 kB L1 data cache
 - 256 kB Level 2 (L2) cache with parity
- Powerful DMA system
- On-chip memory protection
- Integrated safety features

- 19 mm × 19 mm 349/529 BGA (0.8 pitch), RoHS compliant
- Low system power across automotive temperature range

MEMORY

- Large on-chip L2 SRAM with ECC protection, up to 256 kB
- On-chip L2 ROM (512 kB)
- Two Level 3 (L3) interfaces optimized for low system power, providing a 16-bit interface to DDR3 (supporting 1.5 V capable DDR3L devices), DDR2, or LPDDR1 SDRAM devices

ADDITIONAL FEATURES

- Security and Protection
 - Cryptographic hardware accelerators
 - Fast secure boot with IP protection
 - Support for Arm TrustZone
- Accelerators
 - High performance pipelined FFT/IFFT engine
 - FIR, IIR, HAE, SINC offload engines
- AEC-Q100 qualified for automotive applications

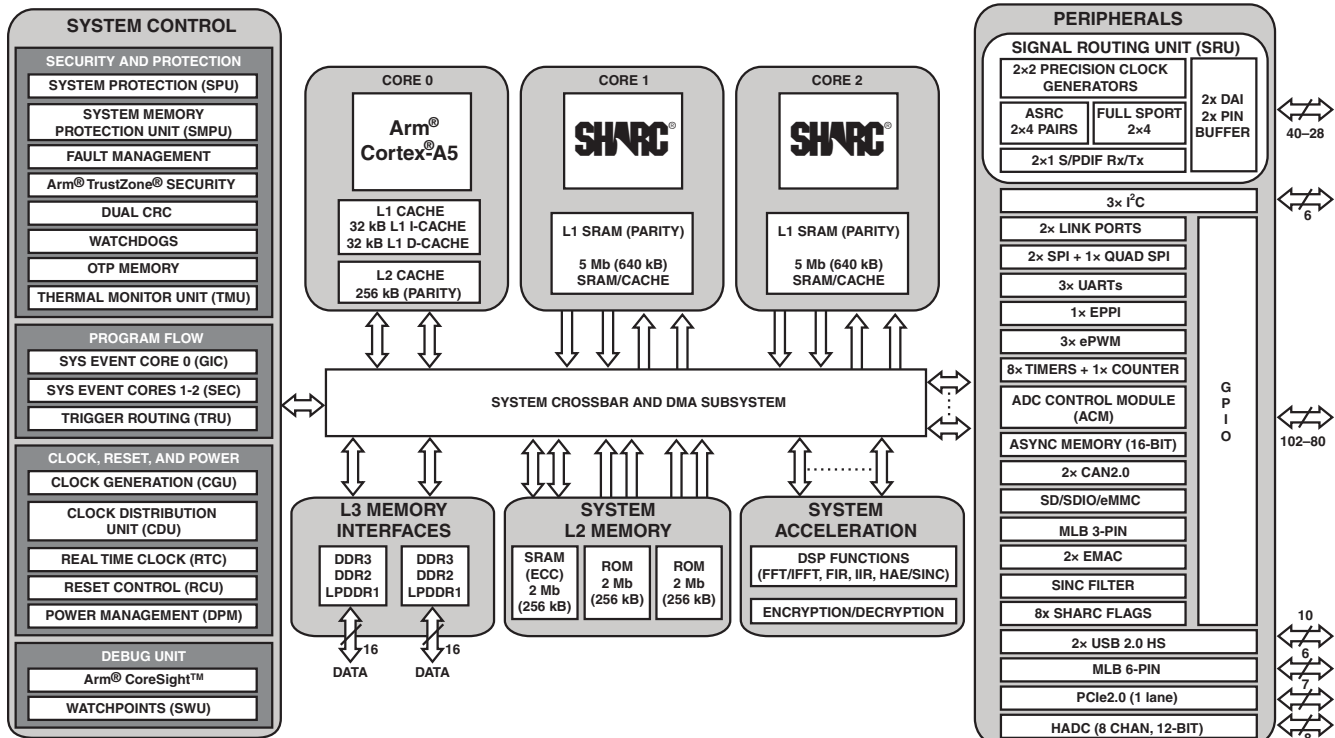

Figure 1. Processor Block Diagram

SHARC, SHARC+, and the SHARC logo are registered trademarks of Analog Devices, Inc.

Rev. B

Document Feedback

Information furnished by Analog Devices is believed to be accurate and reliable. However, no responsibility is assumed by Analog Devices for its use, nor for any infringements of patents or other rights of third parties that may result from its use. Specifications subject to change without notice. No license is granted by implication or otherwise under any patent or patent rights of Analog Devices. Trademarks and registered trademarks are the property of their respective owners.

ADSP-SC582/SC583/SC584/SC587/SC589/ADSP-21583/21584/21587

TABLE OF CONTENTS

System Features	1	GPIO Multiplexing for the 529-Ball CSP_BGA Package ...	55
Memory	1	ADSP-SC58x/ADSP-2158x Designer Quick Reference	58
Additional Features	1	Specifications	79
Table of Contents	2	Operating Conditions	79
Revision History	2	Electrical Characteristics	83
General Description	3	HADC	87
ARM Cortex-A5 Processor	5	TMU	87
SHARC Processor	6	Absolute Maximum Ratings	88
SHARC+ Core Architecture	8	ESD Caution	88
System Infrastructure	10	Timing Specifications	89
System Memory Map	11	Output Drive Currents	153
Security Features	14	Test Conditions	155
Security Features Disclaimer	15	Environmental Conditions	157
Safety Features	15	ADSP-SC58x/ADSP-2158x 349-Ball BGA Ball	
Processor Peripherals	15	Assignments	158
System Acceleration	20	Numerical by Ball Number	158
System Design	21	Alphabetical by Pin Name	160
System Debug	23	Configuration of the 349-Ball CSP_BGA	162
Development Tools	24	ADSP-SC58x/ADSP-2158x 529-Ball BGA Ball	
Additional Information	25	Assignments	163
Related Signal Chains	25	Numerical by Ball Number	163
ADSP-SC58x/ADSP-2158x Detailed Signal		Alphabetical by Pin Name	166
Descriptions	26	Configuration of the 529-Ball CSP_BGA	169
349-Ball CSP_BGA Signal Descriptions	31	Outline Dimensions	170
GPIO Multiplexing for the 349-Ball CSP_BGA Package ..	40	Surface-Mount Design	171
529-Ball CSP_BGA Signal Descriptions	43	Automotive Products	172
		Ordering Guide	173

REVISION HISTORY

12/2018—Rev. A to Rev. B

Changes to Additional Features	1	Changes to ADSP-SC58x/ADSP-2158x Designer Quick Reference	58
Changes to Table 3, General Description	3	Deleted Package Information from Specifications	79
Changes to One Time Programmable Memory (OTP)	10	Changes to Operating Conditions	79
Changes to Table 7 and Table 8, System Memory Map	11	Changes to Table 28, Operating Conditions	79
Changes to Housekeeping Analog-to-Digital Converter (HADC)	19	Changes to Table 29, Clock Related Operating Conditions	81
Changes to Media Local Bus (Media LB)	19	Changes to Total Internal Power Dissipation	85
Changes to ADSP-SC58x/ADSP-2158x Detailed Signal Descriptions	26	Changes to Universal Serial Bus (USB)	138
Changes to ADSP-SC58x/ADSP-2158x 349-Ball CSP_BGA Signal Descriptions	31	Changes to 10/100 EMAC Timing (ETH0 and ETH1)	139
Changes to ADSP-SC58x/ADSP-2158x 529-Ball CSP_BGA Signal Descriptions	43	Changes to Program Trace Macrocell (PTM) Timing	151
		Changes to Test Conditions	155
		Changes to Automotive Products	172

ADSP-SC582/SC583/SC584/SC587/SC589/ADSP-21583/21584/21587

GENERAL DESCRIPTION

The ADSP-SC58x/ADSP-2158x processors are members of the SHARC® family of products. The ADSP-SC58x processor is based on the SHARC+ dual core and the Arm® Cortex®-A5 core. The ADSP-SC58x/ADSP-2158x SHARC processors are members of the SIMD SHARC family of digital signal processors (DSPs) that feature Analog Devices, Inc., Super Harvard Architecture®. These 32-bit/40-bit/64-bit floating-point processors are optimized for high performance audio/floating-point applications with large, on-chip, static random-access memory (SRAM), multiple internal buses that eliminate input/output (I/O) bottlenecks, and innovative digital audio interfaces (DAI). New additions to the SHARC+ core include cache enhancements and branch prediction, while maintaining instruction set compatibility to previous SHARC products.

By integrating a set of industry leading system peripherals and memory (see [Table 1](#), [Table 2](#), and [Table 3](#)), the Arm Cortex-A5 and SHARC processor is the platform of choice for applications that require programmability similar to reduced instruction set computing (RISC), multimedia support, and leading edge signal processing in one integrated package. These applications span a wide array of markets, including automotive, professional audio, and industrial-based applications that require high floating-point performance.

[Table 2](#) provides comparison information for features that vary across the standard processors. (N/A in the table means not applicable.)

[Table 3](#) provides comparison information for features that vary across the automotive processors. (N/A in the table means not applicable.)

Table 1. Common Product Features

Product Features	ADSP-SC58x/ADSP-2158x
DAI (includes SRU)	2
Full SPORTs	4 per DAI
S/PDIF receive/transmit	1 per DAI
ASRCs	4 pair per DAI
PCGs	2 per DAI
I ² C (TWI)	3
Quad-data bit SPI	1
Dual-data bit SPI	2
CAN2.0	2
UARTs	3
Link ports	2
Enhanced PPI	1
GP timer ¹	8
GP counter	1
Enhanced PWMs ²	3
Watchdog timers	2
ADC control module	Yes
Static memory controller	Yes
Hardware accelerators	
High performance FFT/IFFT	Yes
FIR/IIR	Yes
Harmonic analysis engine	Yes
SINC filter	Yes
Security cryptographic engine	Yes
Multichannel 12-bit ADC	8-channel

¹ Eight timers are available in the 529-BGA package only. The 349-BGA package does not include Timer 6 and Timer 7.

² On the 349-BGA package, the PWM2_AH/AL and PWM2_BH/BL signals are not available. The PWM2_CH/CL and PWM2_DH/DL signals, however, are available and can be used in conjunction with PWM2_TRIP0 and PWM2_SYNC signals.

ADSP-SC582/SC583/SC584/SC587/SC589/ADSP-21583/21584/21587

Table 2. Comparison of ADSP-SC58x/ADSP-2158x Processor Features

Processor Feature	ADSP-SC582	ADSP-SC583	ADSP-SC584	ADSP-SC587	ADSP-SC589	ADSP-21583	ADSP-21584	ADSP-21587
Arm Cortex-A5 (MHz, Max)	500	500	500	500	500	N/A	N/A	N/A
Arm Core L1 Cache (I, D kB)	32, 32	32, 32	32, 32	32, 32	32, 32	N/A	N/A	N/A
Arm Core L2 Cache (kB)	256	256	256	256	256	N/A	N/A	N/A
SHARC+ Core1 (MHz, Max)	500	500	500	500	500	500	500	500
SHARC+ Core2 (MHz, Max)	N/A	500	500	500	500	500	500	500
SHARC L1 SRAM (kB)	640	384	640	640	640	384	640	640
System Memory	L2 SRAM (Shared) (kB)	256	256	256	256	256	256	256
	L2 ROM (Shared) (kB)	512	512	512	512	512	512	512
	DDR3/DDR2/LPDDR1	1	1	1	2	2	1	2
	Controller (16-bit)							
USB 2.0 HS + PHY (Host/Device/OTG)	1	1	1	1	1	N/A	N/A	N/A
USB 2.0 HS + PHY (Host/Device)	N/A	N/A	N/A	1	1	N/A	N/A	N/A
10/100 Std EMAC	N/A	N/A	N/A	1	1	N/A	N/A	N/A
10/100/1000 /AVB EMAC + Timer IEEE 1588	1	1	1	1	1	N/A	N/A	N/A
SDIO/eMMC	N/A	N/A	N/A	1	1	N/A	N/A	N/A
PCIe 2.0 (1 Lane)	N/A	N/A	N/A	N/A	1	N/A	N/A	N/A
RTC	N/A	N/A	N/A	1	1	N/A	N/A	1
GPIO Ports	Port A to E	Port A to E	Port A to E	Port A to G	Port A to G	Port A to E	Port A to E	Port A to G
GPIO + DAI Pins	80 + 28	80 + 28	80 + 28	102 + 40	102 + 40	80 + 28	80 + 28	102 + 40
19 mm × 19 mm Package Options	349-BGA	349-BGA	349-BGA	529-BGA	529-BGA	349-BGA	349-BGA	529-BGA

Table 3. Comparison of ADSP-SC58x/ADSP-2158x Processor Features for Automotive

Processor Feature	ADSP-SC582W	ADSP-SC583W	ADSP-SC584W	ADSP-SC587W	ADSP-21583W	ADSP-21584W
Arm Cortex-A5 (MHz, Max)	450	450	500	500	N/A	N/A
Arm Core L1 Cache (I, D kB)	32, 32	32, 32	32, 32	32, 32	N/A	N/A
Arm Core L2 Cache (kB)	256	256	256	256	N/A	N/A
SHARC+ Core1 (MHz, Max)	450	450	500	500	450	500
SHARC+ Core2 (MHz, Max)	N/A	450	500	500	450	500
SHARC L1 SRAM (kB)	640	384	640	640	384	640
System Memory	L2 SRAM (Shared) (kB)	256	256	256	256	256
	L2 ROM (Shared) (kB)	512	512	512	512	512
	DDR3/DDR2/LPDDR1	1	1	1	2	1
	Controller (16-bit)					
USB 2.0 HS + PHY (Host/Device/OTG)	1	1	1	1	N/A	N/A
USB 2.0 HS + PHY (Host/Device)	N/A	N/A	N/A	1	N/A	N/A
10/100 Std EMAC	N/A	N/A	N/A	1	N/A	N/A
10/100/1000/AVB EMAC + Timer IEEE 1588	1	1	1	1	N/A	N/A
SDIO/eMMC	N/A	N/A	N/A	1	N/A	N/A
PCIe 2.0 (1 Lane)	N/A	N/A	N/A	N/A	N/A	N/A
MLB 3-Pin/6-Pin	1	1	1	1	1	1
RTC	N/A	N/A	N/A	1	N/A	N/A
GPIO Ports	Port A to E	Port A to E	Port A to E	Port A to G	Port A to E	Port A to E
GPIO + DAI Pins	80 + 28	80 + 28	80 + 28	102 + 40	80 + 28	80 + 28
19 mm × 19 mm Package Options	349-BGA	349-BGA	349-BGA	529-BGA	349-BGA	349-BGA

ADSP-SC582/SC583/SC584/SC587/SC589/ADSP-21583/21584/21587

ARM CORTEX-A5 PROCESSOR

The Arm Cortex-A5 processor (see [Figure 2](#)) is a high performance processor with the following features:

- Instruction cache unit (32 kB) and data L1 cache unit (32 Kb)
- In order pipeline with dynamic branch prediction
- Arm, Thumb®, and ThumbEE instruction set support
- Arm TrustZone® security extensions
- Harvard L1 memory system with a memory management unit (MMU)
- Arm7™ debug architecture
- Trace support through an embedded trace macrocell (ETM) interface
- Extension—vector floating-point unit (IEEE 754) with trapless execution
- Extension—media processing engine (MPE) with NEON™ technology
- Extension—Jazelle® hardware acceleration



Figure 2. Arm Cortex-A5 Processor Block Diagram

ADSP-SC582/SC583/SC584/SC587/SC589/ADSP-21583/21584/21587

Generic Interrupt Controller (GIC), PL390 (ADSP-SC58x Only)

The generic interrupt controller (GIC) is a centralized resource for supporting and managing interrupts. The GIC splits into the distributor block (GICPORT0) and the CPU interface block (GICPORT1).

Generic Interrupt Controller Port0 (GICPORT0)

The GICPORT0 distributor block performs interrupt prioritization and distribution to the GICPORT1 blocks that connect to the processors in the system. It centralizes all interrupt sources, determines the priority of each interrupt, and forwards the interrupt with the highest priority to the interface, for priority masking and preemption handling.

Generic Interrupt Controller Port1 (GICPORT1)

The GICPORT1 CPU interface block performs priority masking and preemption handling for a connected processor in the system. GICPORT1 supports 8 software generated interrupts (SGIs) and 254 shared peripheral interrupts (SPIs).

L2 Cache Controller, PL310 (ADSP-SC58x Only)

The L2 cache controller, PL310 (see [Figure 2](#)), works efficiently with the Arm Cortex-A5 processors that implement system fabric. The cache controller directly interfaces on the data and instruction interface. The internal pipelining of the cache controller is optimized to enable the processors to operate at the same clock frequency. The cache controller supports the following:

- Two read/write 64-bit slave ports, one connected to the Arm Cortex-A5 instruction and data interfaces, and one connecting the Arm Cortex-A5 and SHARC+ cores for data coherency.
- Two read/write 64-bit master ports for interfacing with the system fabric.

SHARC PROCESSOR

[Figure 3](#) shows the SHARC processor integrates a SHARC+ SIMD core, L1 memory crossbar, I/D cache controller, L1 memory blocks, and the master/slave ports. [Figure 4](#) shows the SHARC+ SIMD core block diagram.

The SHARC processor supports a modified Harvard architecture in combination with a hierarchical memory structure. L1 memories typically operate at the full processor speed with little or no latency.

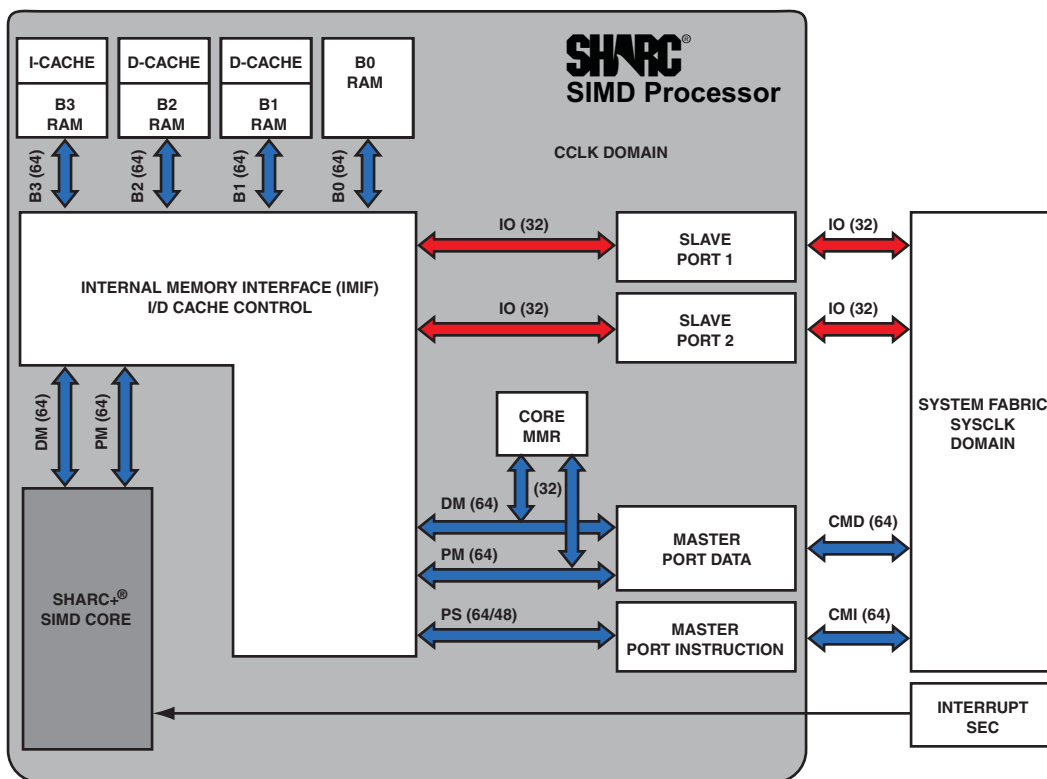

Figure 3. SHARC Processor Block Diagram

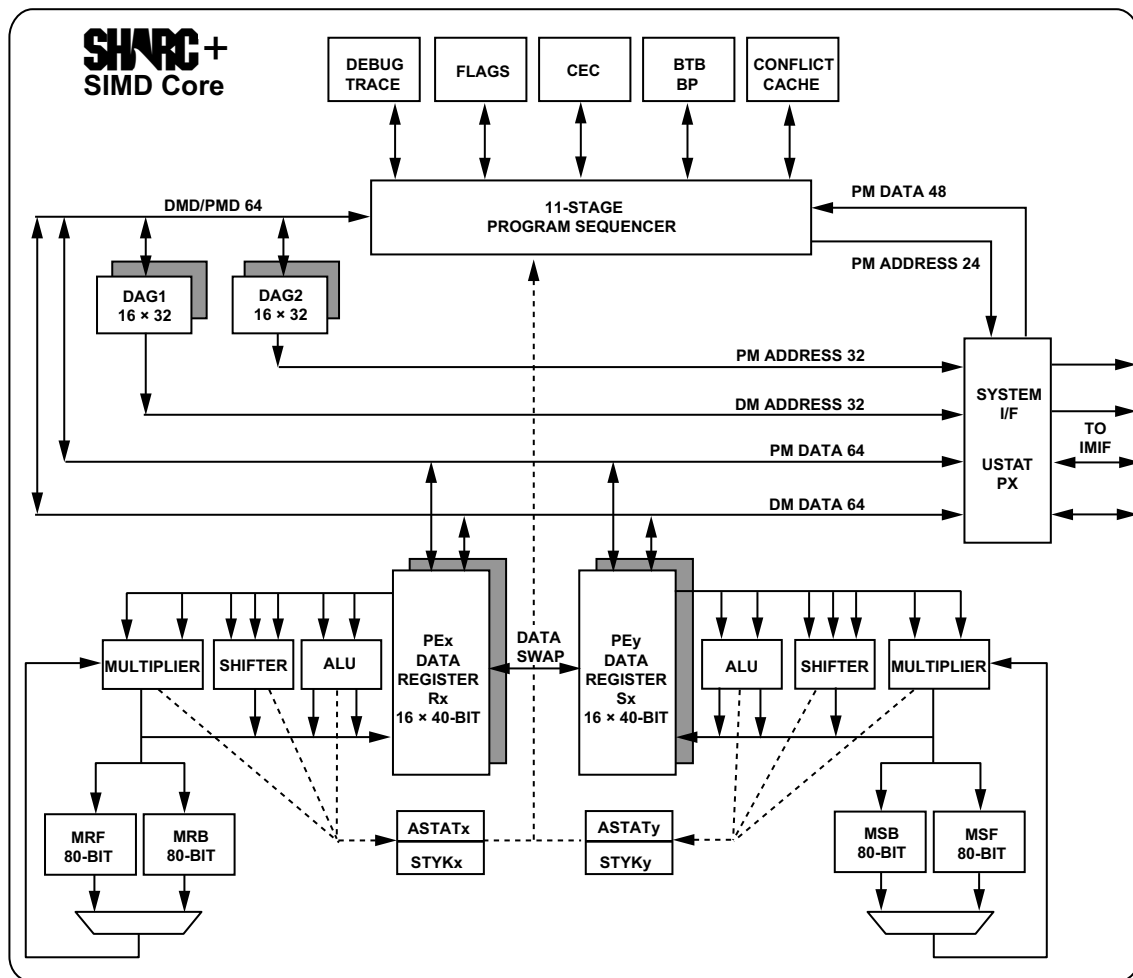

Figure 4. SHARC+ SIMD Core Block Diagram

L1 Memory

Figure 5 shows the ADSP-SC58x/ADSP-2158x memory map. Each SHARC+ core has a tightly coupled L1 SRAM of up to 5 Mb. Each SHARC+ core can access code and data in a single cycle from this memory space. The Arm Cortex-A5 core can also access this memory space with multicycle accesses.

In the SHARC+ core private address space, both cores have L1 memory.

SHARC+ core memory-mapped register (CMMR) address space is 0x 0000 0000 through 0x 0003 FFFF in normal word (32-bit). Each block can be configured for different combinations of code and data storage. Of the 5 Mb SRAM, up to 1024 Kb can be configured for data memory (DM), program memory (PM), and instruction cache. Each memory block supports single-cycle, independent accesses by the core processor and I/O processor. The memory architecture, in combination with its separate on-chip buses, allows two data transfers from the core and one from the DMA engine in a single cycle. The SRAM of the processor can be configured as a maximum of 160k words of 32-bit data, 320k words of 16-bit data,

106.7k words of 48-bit instructions (or 40-bit data), or combinations of different word sizes up to 5 Mb. All of the memory can be accessed as 8-bit, 16-bit, 32-bit, 48-bit, or 64-bit words. Support of a 16-bit floating-point storage format doubles the amount of data that can be stored on chip.

Conversion between the 32-bit floating-point and 16-bit floating-point formats is performed in a single instruction. While each memory block can store combinations of code and data, accesses are most efficient when one block stores data using the DM bus for transfers, and the other block stores instructions and data using the PM bus for transfers.

Using the DM and PM buses, with each bus dedicated to a memory block, assures single-cycle execution with two data transfers. In this case, the instruction must be available in the cache. The system configuration is flexible, but a typical configuration is 512 Kb DM, 128 Kb PM, and 128 Kb of instruction cache, with the remaining L1 memory configured as SRAM. Each addressable memory space outside the L1 memory can be accessed either directly or via cache.

ADSP-SC582/SC583/SC584/SC587/SC589/ADSP-21583/21584/21587

The memory map in Table 4 gives the L1 memory address space and shows multiple L1 memory blocks offering a configurable mix of SRAM and cache.

L1 Master and Slave Ports

Each SHARC+ core has two master and two slave ports to and from the system fabric. One master port fetches instructions. The second master port drives data to the system world. Both slave ports allow conflict free core/direct memory access (DMA) streams to the individual memory blocks. For slave port addresses, refer to the L1 memory address map in Table 4.

L1 On-Chip Memory Bandwidth

The internal memory architecture allows programs to have four accesses at the same time to any of the four blocks, assuming no block conflicts. The total bandwidth is realized using both the DMD and PMD buses.

Instruction and Data Cache

The ADSP-SC58x/ADSP-2158x processors also include a traditional instruction cache (I-cache) and two data caches (D-cache) (PM and DM caches). These caches support one instruction access and two data accesses over the DM and PM buses, per CCLK cycle. The cache controllers automatically manage the configured L1 memory. The system can configure part of the L1 memory for automatic management by the cache controllers. The sizes of these caches are independently configurable from 0 kB to a maximum of 128 kB each. The memory not managed by the cache controllers is directly addressable by the processors. The controllers ensure the data coherence between the two data caches. The caches provide user-controllable features such as full and partial locking, range-bound invalidation, and flushing.

System Event Controller (SEC) Input

The output of the system event controller (SEC) controller is forwarded to the core event controller (CEC) to respond directly to all unmasked system-based interrupts. The SEC also supports nesting including various SEC interrupt channel arbitration options. For all SEC channels, the processor automatically stacks the arithmetic status (ASTATx and ASTATy) registers and mode (MODE1) register in parallel with the interrupt servicing.

Core Memory-Mapped Registers (CMMR)

The core memory-mapped registers control the L1 instruction and data cache, BTB, L2 cache, parity error, system control, debug, and monitor functions.

SHARC+ CORE ARCHITECTURE

The ADSP-SC58x/ADSP-2158x processors are code compatible at the assembly level with the ADSP-2148x, ADSP-2147x, ADSP-2146x, ADSP-2137x, ADSP-2136x, ADSP-2126x, ADSP-2116x, and with the first-generation ADSP-2106x SHARC processors.

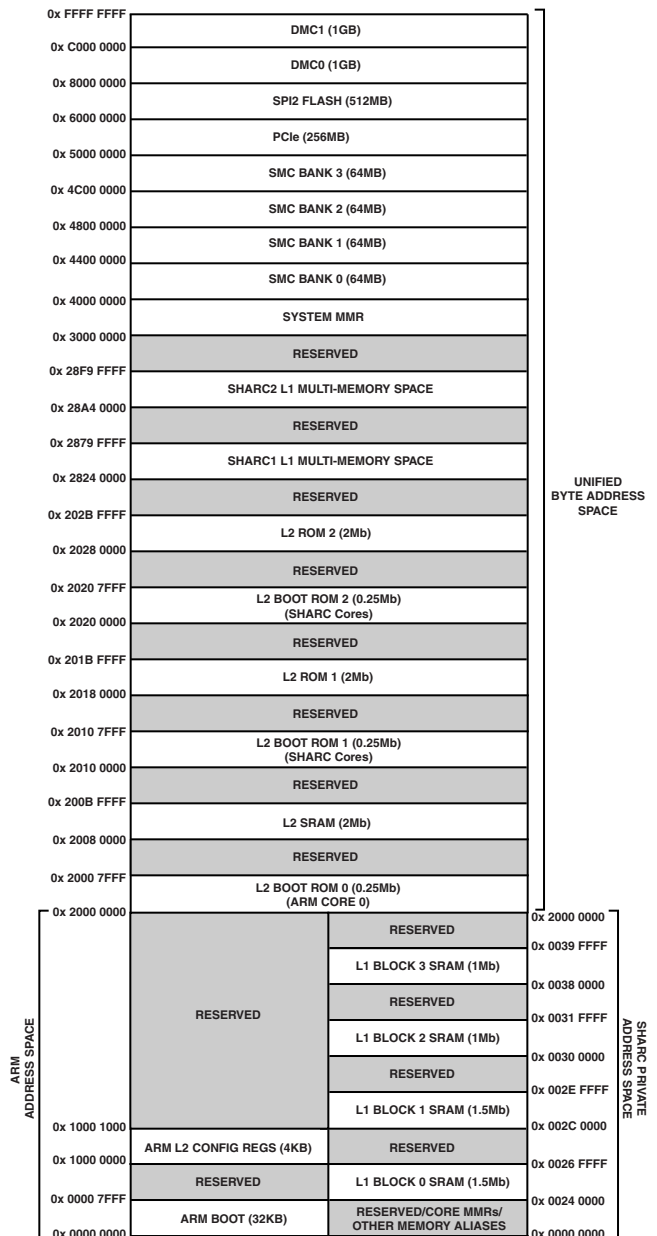

Figure 5. ADSP-SC58x/ADSP-2158x Memory Map

The ADSP-SC58x/ADSP-2158x processors share architectural features with the ADSP-2126x, ADSP-2136x, ADSP-2137x, ADSP-214xx, and ADSP-2116x SIMD SHARC processors, shown in Figure 4 and detailed in the following sections.

SIMD Computational Engine

The SHARC+ core contains two computational processing elements that operate as a single-instruction, multiple data (SIMD) engine.

The processing elements are referred to as PEx and PEy data registers and each contain an arithmetic logic unit (ALU), multiplier, shifter, and register file. PEx is always active and PEy is enabled by setting the PEYEN mode bit in the mode control register (MODE1).

Single instruction multiple data (SIMD) mode allows the processors to execute the same instruction in both processing elements, but each processing element operates on different data. This architecture efficiently executes math intensive DSP algorithms. In addition to all the features of previous generation SHARC cores, the SHARC+ core also provides a new and simpler way to execute an instruction only on the PEy data register.

SIMD mode also affects the way data transfers between memory and processing elements because to sustain computational operation in the processing elements requires twice the data bandwidth. Therefore, entering SIMD mode doubles the bandwidth between memory and the processing elements. When using the DAGs to transfer data in SIMD mode, two data values transfer with each memory or register file access.

Independent, Parallel Computation Units

Within each processing element is a set of pipelined computational units. The computational units consist of a multiplier, arithmetic/logic unit (ALU), and shifter. These units are arranged in parallel, maximizing computational throughput. These computational units support IEEE 32-bit single-precision floating-point, 40-bit extended-precision floating-point, IEEE 64-bit double-precision floating-point, and 32-bit fixed-point data formats.

A multifunction instruction set supports parallel execution of ALU and multiplier operations. In SIMD mode, the parallel ALU and multiplier operations occur in both processing elements per core.

All processing operations take one cycle to complete. For all floating-point operations, the processor takes two cycles to complete in case of data dependency. Double-precision floating-point data take two to six cycles to complete. The processor stalls for the appropriate number of cycles for an interlocked pipeline plus data dependency check.

Core Timer

Each SHARC+ processor core also has a timer. This extra timer is clocked by the internal processor clock and is typically used as a system tick clock for generating periodic operating system interrupts.

Data Register File

Each processing element contains a general-purpose data register file. The register files transfer data between the computation units and the data buses, and store intermediate results. These 10-port, 32-register register files (16 primary, 16 secondary), combined with the enhanced Harvard architecture of the processor, allow unconstrained data flow between computation units and internal memory. The registers in the PEx data register file are referred to as R0–R15 and in the PEy data register file as S0–S15.

Context Switch

Many of the registers of the processor have secondary registers that can activate during interrupt servicing for a fast context switch. The data, DAG, and multiplier result registers have secondary registers. The primary registers are active at reset, while control bits in MODE1 activate the secondary registers.

Universal Registers (USTAT)

General-purpose tasks use the universal registers. The four USTAT registers allow easy bit manipulations (set, clear, toggle, test, XOR) for all control and status peripheral registers.

The data bus exchange register (PX) permits data to pass between the 64-bit PM data bus and the 64-bit DM data bus or between the 40-bit register file and the PM or DM data bus. These registers contain hardware to handle the data width difference.

Data Address Generators With Zero-Overhead Hardware Circular Buffer Support

For indirect addressing and implementing circular data buffers in hardware, the ADSP-SC58x/ADSP-2158x processor uses the two data address generators (DAGs). Circular buffers allow efficient programming of delay lines and other data structures required in digital signal processing, and are commonly used in digital filters and Fourier transforms. The two DAGs of the processors contain sufficient registers to allow the creation of up to 32 circular buffers (16 primary register sets and 16 secondary sets). The DAGs automatically handle address pointer wrap-around, reduce overhead, increase performance, and simplify implementation. Circular buffers can start and end at any memory location.

Flexible Instruction Set Architecture (ISA)

The ISA, a 48-bit instruction word, accommodates various parallel operations for concise programming. For example, the processors can conditionally execute a multiply, an add, and a subtract in both processing elements while branching and fetching up to four 32-bit values from memory—all in a single instruction. Additionally, the double-precision floating-point instruction set is an addition to the SHARC+ core.

Variable Instruction Set Architecture (VISA)

In addition to supporting the standard 48-bit instructions from previous SHARC processors, the SHARC+ core processors support 16-bit and 32-bit opcodes for many instructions, formerly 48-bit in the ISA. This feature, called variable instruction set architecture (VISA), drops redundant or unused bits within the 48-bit instruction to create more efficient and compact code. The program sequencer supports fetching these 16-bit and 32-bit instructions from both internal and external memories. VISA is not an operating mode; it is only address dependent (refer to memory map ISA/VISA address spaces in [Table 7](#)). Furthermore, it allows jumps between ISA and VISA instruction fetches.

ADSP-SC582/SC583/SC584/SC587/SC589/ADSP-21583/21584/21587

Single-Cycle Fetch of Instructional Four Operands

The ADSP-SC58x/ADSP-2158x processors feature an enhanced Harvard architecture in which the DM bus transfers data and PM bus transfers both instructions and data.

With the separate program memory bus, data memory buses, and on-chip instruction conflict-cache, the processor can simultaneously fetch four operands (two over each data bus) and one instruction from the conflict cache, in a single cycle.

Core Event Controller (CEC)

The SHARC+ core generates various core interrupts (including arithmetic and circular buffer instruction flow exceptions) and SEC events (debug/monitor and software). The core only responds to unmasked interrupts (enabled in the IMASK register).

Instruction Conflict-Cache

The processors include a 32-entry instruction cache that enables three-bus operation for fetching an instruction and four data values. The cache is selective—only the instructions that require fetches conflict with the PM bus data accesses cache. This cache allows full speed execution of core, looped operations, such as digital filter multiply accumulates, and fast Fourier transforms (FFT) butterfly processing. The conflict cache serves for on-chip bus conflicts only.

Branch Target Buffer/Branch Predictor

Implementation of a hardware-based branch predictor (BP) and branch target buffer (BTB) reduce branch delay. The program sequencer supports efficient branching using the BTB for conditional and unconditional instructions.

Addressing Spaces

In addition to traditionally supported long word, normal word, extended precision word and short word addressing aliases, the processors support byte addressing for the data and instruction accesses. The enhanced ISA/VISA provides new instructions for accessing all sizes of data from byte space as well as converting word addresses to byte and byte to word addresses.

Additional Features

The enhanced ISA/VISA of the ADSP-SC58x/ADSP-2158x processors also provides a memory barrier instruction for data synchronization, exclusive data access support for multicore data sharing, and exclusive data access to enable multiprocessor programming. To enhance the reliability of the application, L1 data RAMs support parity error detection logic for every byte. Additionally, the processors detect illegal opcodes. Core interrupts flag both errors. Master ports of the core also detect for failed external accesses.

SYSTEM INFRASTRUCTURE

The following sections describe the system infrastructure of the ADSP-SC58x/ADSP-2158x processors.

System L2 Memory

A system L2 SRAM memory of 2 Mb (256 kB) and two ROM memories, each 2 Mb (256 kB), are available to both SHARC+ cores, the Arm Cortex-A5 core, and the system DMA channels (see [Table 5](#)). All L2 SRAM/ROM blocks are subdivided into eight banks to support concurrent access to the L2 memory ports. Memory accesses to the L2 memory space are multicycle accesses by both the Arm Cortex-A5 and SHARC+ cores.

The memory space is used for various cases including

- Arm Cortex-A5 to SHARC+ core data sharing and inter-core communications
- Accelerator and peripheral sources and destination memory to avoid accessing data in the external memory
- A location for DMA descriptors
- Storage for additional data for either the Arm Cortex-A5 or SHARC+ cores to avoid external memory latencies and reduce external memory bandwidth
- Storage for incoming Ethernet traffic to improve performance
- Storage for data coefficient tables cached by the SHARC+ core

See the [System Memory Protection Unit \(SMPU\)](#) section for options in limiting access by specific cores and DMA masters.

The Arm Cortex-A5 core has an L1 instruction and data cache, each of which is 32 kB in size. The core also has an L2 cache controller of 256 kB. When enabling the caches, accesses to all other memory spaces (internal and external) go through the cache.

SHARC+ Core L1 Memory in Multiprocessor Space

The Arm Cortex-A5 core can access the L1 memory of the SHARC+ core. See [Table 6](#) for the L1 memory address in multiprocessor space. The SHARC+ core can access the L1 memory of the other SHARC+ core in the multiprocessor space.

One Time Programmable Memory (OTP)

The processors feature 7 kB of one time programmable (OTP) memory which is memory-map accessible. This memory contains space for programmable unique keys and supports secure boot and secure operation.

I/O Memory Space

The static memory controller (SMC) is programmed to control up to two blocks of external memories or memory-mapped devices, with flexible timing parameters. Each block occupies an 8 Kb segment regardless of the size of the device used. Mapped I/Os also include PCIe data and SPI2 memory address space (see [Table 7](#)).

ADSP-SC582/SC583/SC584/SC587/SC589/ADSP-21583/21584/21587

SYSTEM MEMORY MAP

Table 4. L1 Block 0, Block 1, Block 2, and Block 3 SHARC+ Addressing Memory Map (Private Address Space)

Memory	Long Word (64 Bits)	Extended Precision/ ISA Code (48 Bits)	Normal Word (32 Bits)	Short Word/ VISA Code (16 Bits)	Byte Access (8 Bits)
L1 Block 0 SRAM (1.5 Mb)	0x00048000– 0x0004DFFF	0x00090000– 0x00097FFF	0x00090000– 0x0009BFFF	0x00120000– 0x00137FFF	0x00240000– 0x0026FFFF
L1 Block 1 SRAM (1.5 Mb)	0x00058000– 0x0005DFFF	0x000B0000– 0x000B7FFF	0x000B0000– 0x000BBFFF	0x00160000– 0x00177FFF	0x002C0000– 0x002EFFFF
L1 Block 2 SRAM (1 Mb)	0x00060000– 0x00063FFF	0x000C0000– 0x000C5554	0x000C0000– 0x000C7FFF	0x00180000– 0x0018FFFF	0x00300000– 0x0031FFFF
L1 Block 3 SRAM (1 Mb)	0x00070000– 0x00073FFF	0x000E0000– 0x000E5554	0x000E0000– 0x000E7FFF	0x001C0000– 0x001CFFFF	0x00380000– 0x0039FFFF

Table 5. L2 Memory Addressing Map

Memory ¹	Byte Address Space Arm Cortex-A5: Data Access and Instruction Fetch; SHARC+: Data Access	Normal Word Address Space for Data Access SHARC+	Instruction Fetch VISA Address Space SHARC+	Instruction Fetch ISA Address Space SHARC+
L2 Boot ROM0 ²	Arm: 0x00000000–0x00007FFF SHARC+/DMA: 0x20000000–0x20007FFF	0x08000000–0x08001FFF	0x00B80000–0x00B83FFF	0x00580000–0x00581555
L2 RAM (2 Mb)	0x20080000–0x200BFFFF	0x08020000–0x0802FFFF	0x00BA0000–0x00BBFFFF	0x005A0000–0x005AAAAF
L2 Boot ROM1	0x20100000–0x20107FFF	0x08040000–0x08041FFF	0x00B00000–0x00B03FFF	0x00500000–0x00501555
L2 ROM1	0x20180000–0x201BFFFF	0x08060000–0x0806FFFF	0x00B20000–0x00B3FFFF	0x00520000–0x0052AAAAF
L2 Boot ROM2 ³	0x20200000–0x20207FFF	0x08080000–0x08081FFF	0x00B40000–0x00B43FFF	0x00540000–0x00541555
L2 ROM2	0x20280000–0x202BFFFF	0x080A0000–0x080AFFFF	0x00B60000–0x00B7FFFF	0x00560000–0x0056AAAAF

¹ All L2 RAM/ROM blocks are subdivided into eight banks.

² For ADSP-SC58x products, the L2 Boot ROM0 byte address space is 0x 0000 0000–0x 0000 7FFF.

³ L2 Boot ROM address for ADSP-2158x products.

Table 6. SHARC+ L1 Memory in Multiprocessor Space

		Memory Block	Byte Address Space for Arm Cortex-A5 and SHARC+	Normal Word Address Space for SHARC+
L1 memory of SHARC1 in multiprocessor space	Address via Slave1 Port	Block 0	0x28240000–0x2826FFFF	0x0A090000–0x0A09BFFF
		Block 1	0x282C0000–0x282EFFFF	0x0A0B0000–0x0A0BBFFF
		Block 2	0x28300000–0x2831FFFF	0x0A0C0000–0x0A0C7FFF
		Block 3	0x28380000–0x2839FFFF	0x0A0E0000–0x0A0E7FFF
	Address via Slave2 Port	Block 0	0x28640000–0x2866FFFF	0x0A190000–0x0A19BFFF
		Block 1	0x286C0000–0x286EFFFF	0x0A1B0000–0x0A1BBFFF
		Block 2	0x28700000–0x2871FFFF	0x0A1C0000–0x0A1C7FFF
L1 memory of SHARC2 in multiprocessor space	Address via Slave1 Port	Block 0	0x28A40000–0x28A6FFFF	0x0A290000–0x0A29BFFF
		Block 1	0x28AC0000–0x28AEFFFF	0x0A2B0000–0x0A2BBFFF
		Block 2	0x28B00000–0x28B1FFFF	0x0A2C0000–0x0A2C7FFF
		Block 3	0x28B80000–0x28B9FFFF	0x0A2E0000–0x0A2E7FFF
	Address via Slave2 Port	Block 0	0x28E40000–0x28E6FFFF	0x0A390000–0x0A39BFFF
		Block 1	0x28EC0000–0x28EEFFFF	0x0A3B0000–0x0A3BBFFF
		Block 2	0x28F00000–0x28F1FFFF	0x0A3C0000–0x0A3C7FFF
		Block 3	0x28F80000–0x28F9FFFF	0x0A3E0000–0x0A3E7FFF

ADSP-SC582/SC583/SC584/SC587/SC589/ADSP-21583/21584/21587

Table 7. Memory Map of Mapped I/Os¹

	Byte Address Space Arm Cortex-A5: Data Access and Instruction Fetch; SHARC+: Data Access	Normal Word Address Space SHARC+ Data Access	VISA Address Space SHARC+ Instruction Fetch	ISA Address Space SHARC+ Instruction Fetch
SMC Bank 0 (64 MB)	0x40000000–0x43FFFFFF	0x01000000–0x01FFFFFF	0x00F00000–0x00F3FFFF	0x00700000–0x0073FFFF
SMC Bank 1 (64 MB)	0x44000000–0x47FFFFFF	Not applicable	Not applicable	Not applicable
SMC Bank 2 (64 MB)	0x48000000–0x4BFFFFFF	Not applicable	Not applicable	Not applicable
SMC Bank 3 (64 MB)	0x4C000000–0x4FFFFFFF	Not applicable	Not applicable	Not applicable
PCIe Data (256 MB)	0x50000000–0x5007FFFF	0x02000000–0x03FFFFFF	0x00F40000–0x00F7FFFF	0x00740000–0x0077FFFF
	0x50080000–0x5017FFFF		Not applicable	
	0x50180000–0x507FFFFFFF	Not applicable	Not applicable	Not applicable
	0x58000000–0x5FFFFFFF			
SPI2 Memory (512 MB)	0x60000000–0x600FFFFFFF	0x04000000–0x07FFFFFFF	0x00F80000–0x00FFFFFFF	0x00780000–0x007FFFFFFF
	0x60100000–0x602FFFFFFF		Not applicable	
	0x60300000–0x6FFFFFFF		Not applicable	
	0x70000000–0x7FFFFFFF	Not applicable	Not applicable	Not applicable

¹The Arm Cortex-A5 can access the entire byte address space. The SHARC+ VISA/ISA address space for instruction fetch and the normal word address space for data access do not cover the entire byte address space.

Table 8. DMC Memory Map¹

	Byte Address Space Arm Cortex-A5: Data Access and Instruction Fetch; SHARC+: Data Access	Normal Word Address Space SHARC+ Data Access	VISA Address Space SHARC+ Instruction Fetch	ISA Address Space SHARC+ Instruction Fetch
DMC0 (1 GB)	0x80000000–0x805FFFFFFF	0x10000000–0x17FFFFFFF	Not applicable	0x00400000–0x004FFFFFFF
	0x80600000–0x809FFFFFFF		Not applicable	Not applicable
	0x80A00000–0x80FFFFFFF		0x00800000–0x00AFFFFFFF	Not applicable
	0x81000000–0x9FFFFFFF		Not applicable	Not applicable
	0xA0000000–0xBFFFFFFF	Not applicable	Not applicable	Not applicable
DMC1 (1 GB)	0xC0000000–0xC05FFFFFFF	0x18000000–0x1FFFFFFF	Not applicable	0x00600000–0x006FFFFFFF
	0xC0600000–0xC09FFFFFFF		Not applicable	Not applicable
	0xC0A00000–0xC0FFFFFFF		0x00C00000–0x00EFFFFFFF	Not applicable
	0xC1000000–0xDFFFFFFF		Not applicable	Not applicable
	0xE0000000–0xFFFFFFFF	Not applicable	Not applicable	Not applicable

¹The Arm Cortex-A5 can access the entire byte address space. The SHARC+ VISA/ISA address space for instruction fetch and the normal word address space for data access do not cover the entire byte address space.

System Crossbars (SCBs)

The system crossbars (SCBs) are the fundamental building blocks of a switch-fabric style for on-chip system bus interconnection. The SCBs connect system bus masters to system bus slaves, providing concurrent data transfer between multiple bus masters and multiple bus slaves. A hierarchical model—built from multiple SCBs—provides a power and area efficient system interconnection.

The SCBs provide the following features:

- Highly efficient, pipelined bus transfer protocol for sustained throughput
- Full-duplex bus operation for flexibility and reduced latency
- Concurrent bus transfer support to allow multiple bus masters to access bus slaves simultaneously
- Protection model (privileged/secure) support for selective bus interconnect protection

Direct Memory Access (DMA)

The processors use direct memory access (DMA) to transfer data within memory spaces or between a memory space and a peripheral. The processors can specify data transfer operations and return to normal processing while the fully integrated DMA controller carries out the data transfers independent of processor activity.

DMA transfers can occur between memory and a peripheral or between one memory and another memory. Each memory to memory DMA stream uses two channels: one channel is the source channel and the second is the destination channel.

All DMA channels can transport data to and from all on-chip and off-chip memories. Programs can use two types of DMA transfers: descriptor-based or register-based.

Register-based DMA allows the processors to program DMA control registers directly to initiate a DMA transfer. On completion, the DMA control registers automatically update with original setup values for continuous transfer. Descriptor-based DMA transfers require a set of parameters stored within memory to initiate a DMA sequence. Descriptor-based DMA transfers allow multiple DMA sequences to be chained together. Program a DMA channel to set up and start another DMA transfer automatically after the current sequence completes.

The DMA engine supports the following DMA operations:

- A single linear buffer that stops on completion
- A linear buffer with negative, positive, or zero stride length
- A circular autorefreshing buffer that interrupts when each buffer becomes full
- A similar circular buffer that interrupts on fractional buffers, such as at the halfway point
- The 1D DMA uses a set of identical ping pong buffers defined by a linked ring of two-word descriptor sets, each containing a link pointer and an address
- The 1D DMA uses a linked list of four-word descriptor sets containing a link pointer, an address, a length, and a configuration
- The 2D DMA uses an array of one-word descriptor sets, specifying only the base DMA address
- The 2D DMA uses a linked list of multiword descriptor sets, specifying all configurable parameters

Memory Direct Memory Access (MDMA)

The processor supports various MDMA operations, including,

- Standard bandwidth MDMA channels with CRC protection (32-bit bus width, run on SCLK0)
- Enhanced bandwidth MDMA channel (32-bit bus width, runs on SYCLK)
- Maximum bandwidth MDMA channels (64-bit bus width, run on SYCLK, one channel can be assigned to the FFT accelerator)

Extended Memory DMA

Extended memory DMA supports various operating modes such as delay line (which allows processor reads and writes to external delay line buffers and to the external memory) with limited core interaction and scatter/gather DMA (writes to and from noncontiguous memory blocks).

Cyclic Redundant Code (CRC) Protection

The cyclic redundant codes (CRC) protection modules allow system software to calculate the signature of code, data, or both in memory, the content of memory-mapped registers, or periodic communication message objects. Dedicated hardware circuitry compares the signature with precalculated values and triggers appropriate fault events.

For example, every 100 ms the system software initiates the signature calculation of the entire memory contents and compares these contents with expected, precalculated values. If a mismatch occurs, a fault condition is generated through the processor core or the trigger routing unit.

The CRC is a hardware module based on a CRC32 engine that computes the CRC value of the 32-bit data-words presented to it. The source channel of the memory to memory DMA (in memory scan mode) provides data. The data can be optionally forwarded to the destination channel (memory transfer mode). The main features of the CRC peripheral are as follows:

- Memory scan mode
- Memory transfer mode
- Data verify mode
- Data fill mode
- User-programmable CRC32 polynomial
- Bit/byte mirroring option (endianness)
- Fault/error interrupt mechanisms
- 1D and 2D fill block to initialize an array with constants
- 32-bit CRC signature of a block of a memory or an MMR block

Event Handling

The processors provide event handling that supports both nesting and prioritization. Nesting allows multiple event service routines to be active simultaneously. Prioritization ensures that servicing a higher priority event takes precedence over servicing a lower priority event.

The processors provide support for five different types of events:

- An emulation event causes the processors to enter emulation mode, allowing command and control of the processors through the JTAG interface.
- A reset event resets the processors.
- An exceptions event occur synchronously to program flow (in other words, the exception is taken before the instruction is allowed to complete). Conditions triggered on the one side by the SHARC+ core, such as data alignment (SIMD/long word) or compute violations (fixed or floating

ADSP-SC582/SC583/SC584/SC587/SC589/ADSP-21583/21584/21587

point), and illegal instructions cause core exceptions. Conditions triggered on the other side by the SEC, such as error correcting codes (ECC)/parity/watchdog/system clock, cause system exceptions.

- An interrupts event occurs asynchronously to program flow. They are caused by input signals, timers, and other peripherals, as well as by an explicit software instruction.

System Event Controller (SEC)

Both SHARC+ cores feature a system event controller. The SEC features include the following:

- Comprehensive system event source management including interrupt enable, fault enable, priority, core mapping, and source grouping
- A distributed programming model where each system event source control and all status fields are independent of each other
- Determinism where all system events have the same propagation delay and provide unique identification of a specific system event source
- A slave control port that provides access to all SEC registers for configuration, status, and interrupt/fault services
- Global locking that supports a register level protection model to prevent writes to locked registers
- Fault management including fault action configuration, time out, external indication, and system reset

Trigger Routing Unit (TRU)

The trigger routing unit (TRU) provides system-level sequence control without core intervention. The TRU maps trigger masters (generators of triggers) to trigger slaves (receivers of triggers). Slave endpoints can be configured to respond to triggers in various ways. Common applications enabled by the TRU include,

- Automatically triggering the start of a DMA sequence after a sequence from another DMA channel completes
- Software triggering
- Synchronization of concurrent activities

SECURITY FEATURES

The following sections describe the security features of the ADSP-SC58x/ADSP-2158x processors.

Arm TrustZone

The ADSP-SC58x processors provide TrustZone technology that is integrated into the Arm Cortex-A5 processors. The TrustZone technology enables a secure state that is extended throughout the system fabric.

Cryptographic Hardware Accelerators

The ADSP-SC58x/ADSP-2158x processors support standards-based hardware accelerated encryption, decryption, authentication, and true random number generation.

Support for the hardware-accelerated cryptographic ciphers includes the following:

- AES in ECB, CBC, ICM, and CTR modes with 128-bit, 192-bit, and 256-bit keys
- DES in ECB and CBC mode with 56-bit key
- 3DES in ECB and CBC mode with 3x 56-bit key
- ARC4 in stateful, stateless mode, up to 128-bit key

Support for the hardware accelerated hash functions includes the following:

- SHA-1
- SHA-2 with 224-bit and 256-bit digests
- HMAC transforms for SHA-1 and SHA-2
- MD5

Public key accelerator (PKA) is available to offload computation intensive public key cryptography operations.

Both a hardware-based nondeterministic random number generator and pseudorandom number generator are available.

Secure boot is also available with 224-bit elliptic curve digital signatures ensuring integrity and authenticity of the boot stream. Optionally, ensuring confidentiality through AES-128 encryption is available.

Employ secure debug to allow only trusted users to access the system with debug tools.



CAUTION

This product includes security features that can be used to protect embedded nonvolatile memory contents and prevent execution of unauthorized code. When security is enabled on this device (either by the ordering party or the subsequent receiving parties), the ability of Analog Devices to conduct failure analysis on returned devices is limited. Contact Analog Devices for details on the failure analysis limitations for this device.

System Protection Unit (SPU)

The system protection unit (SPU) guards against accidental or unwanted access to an MMR space of the peripheral by providing a write protection mechanism. The user can choose and configure the protected peripherals as well as configure which of the four system MMR masters (two SHARC+ cores, memory DMA, and CoreSight debug) the peripherals are guarded against.

The SPU is also part of the security infrastructure. Along with providing write protection functionality, the SPU is employed to define which resources in the system are secure or nonsecure and to block access to secure resources from nonsecure masters.

System Memory Protection Unit (SMPU)

Synonymously, the system memory protection unit (SMPU) provides memory protection against read and/or write transactions to defined regions of memory. There are SMPU units in the ADSP-SC58x/ADSP-2158x processors for each memory space, except for SHARC L1 and SPI direct memory slave.

The SMPU is also part of the security infrastructure. It allows the user to protect against arbitrary read and/or write transactions and allows regions of memory to be defined as secure and prevent nonsecure masters from accessing those memory regions.

SECURITY FEATURES DISCLAIMER

To our knowledge, the Security Features, when used in accordance with the data sheet and hardware reference manual specifications, provide a secure method of implementing code and data safeguards. However, Analog Devices does not guarantee that this technology provides absolute security. ACCORDINGLY, ANALOG DEVICES HEREBY DISCLAIMS ANY AND ALL EXPRESS AND IMPLIED WARRANTIES THAT THE SECURITY FEATURES CANNOT BE BREACHED, COMPROMISED, OR OTHERWISE CIRCUMVENTED AND IN NO EVENT SHALL ANALOG DEVICES BE LIABLE FOR ANY LOSS, DAMAGE, DESTRUCTION, OR RELEASE OF DATA, INFORMATION, PHYSICAL PROPERTY, OR INTELLECTUAL PROPERTY.

SAFETY FEATURES

The ADSP-SC58x/ADSP-2158x processors are designed to support functional safety applications. While the level of safety is mainly dominated by the system concept, the following primitives are provided by the processors to build a robust safety concept.

Multiparity Bit Protected SHARC+ Core L1 Memories

In the SHARC+ core L1 memory space, whether SRAM or cache, multiple parity bits protect each word to detect the single event upsets that occur in all RAMs. Parity does not protect the cache tags.

Error Correcting Codes (ECC) Protected L2 Memories

Error correcting codes (ECC) correct single event upsets. A single error correct-double error detect (SEC-DED) code protects the L2 memory. By default, ECC is enabled, but it can be disabled on a per bank basis. Single-bit errors correct transparently. If enabled, dual-bit errors can issue a system event or fault. ECC protection is fully transparent to the user, even if L2 memory is read or written by 8-bit or 16-bit entities.

Cyclic Redundant Code (CRC) Protected Memories

While parity bit and ECC protection mainly protect against random soft errors in L1 and L2 memory cells, the cyclic redundant code (CRC) engines can protect against systematic errors (pointer errors) and static content (instruction code) of L1, L2, and even L3 memories (DDR2, LPDDR). The processors feature two CRC engines that are embedded in the memory to memory DMA controllers.

CRC checksums can be calculated or compared automatically during memory transfers, or one or multiple memory regions can be continuously scrubbed by a single DMA work unit as per DMA descriptor chain instructions. The CRC engine also protects data loaded during the boot process.

Signal Watchdogs

The eight general-purpose timers feature modes to monitor off-chip signals. The watchdog period mode monitors whether external signals toggle with a period within an expected range. The watchdog width mode monitors whether the pulse widths of external signals are within an expected range. Both modes help to detect undesired toggling or lack of toggling of system level signals.

System Event Controller (SEC)

Besides system events, the system event controller (SEC) further supports fault management including fault action configuration as timeout, internal indication by system interrupt, or external indication through the `SYS_FAULT` pin and system reset.

PROCESSOR PERIPHERALS

The following sections describe the peripherals of the ADSP-SC58x/ADSP-2158x processors.

Dynamic Memory Controller (DMC)

The 16-bit dynamic memory controller (DMC) interfaces to:

- LPDDR1 (JESD209A) maximum frequency 200 MHz, DDRCLK (64 Mb to 2 Gb)
- DDR2 (JESD79-2E) maximum frequency 400 MHz, DDRCLK (256 Mb to 4 Gb)
- DDR3 (JESD79-3E) maximum frequency 450 MHz, DDRCLK (512 Mb to 8 Gb)
- DDR3L (1.5 V compatible only) maximum frequency 450 MHz, DDRCLK (512 Mb to 8 Gb)

See [Table 8](#) for the DMC memory map.

Digital Audio Interface (DAI)

The processors support two mirrored digital audio interface (DAI) units. Each DAI can connect various peripherals to any of the DAI pins (DAI_PIN20–DAI_PIN01).

The application code makes these connections using the signal routing unit (SRU), shown in [Figure 1](#).

The SRU is a matrix routing unit (or group of multiplexers) that enables the peripherals provided by the DAI to interconnect under software control. This functionality allows easy use of the DAI associated peripherals for a wider variety of applications by using a larger set of algorithms than is possible with nonconfigurable signal paths.

The DAI includes the peripherals described in the following sections (SPORTs, ASRC, S/PDIF, and PCG). DAI Pin Buffers 20 and 19 can change the polarity of the input signals. Most signals of the peripherals belonging to different DAIs cannot be interconnected, with few exceptions.

ADSP-SC582/SC583/SC584/SC587/SC589/ADSP-21583/21584/21587

The DAI_PINx pin buffers may also be used as GPIO pins. DAI input signals allow the triggering of interrupts on the rising edge, the falling edge, or both edges.

See the “Digital Audio Interface (DAI)” chapter of the [ADSP-SC58x/ADSP-2158x SHARC+ Processor Hardware Reference](#) for complete information on the use of the DAIs and SRUs.

Serial Ports (SPORTs)

The processors feature eight synchronous full serial ports. These ports provide an inexpensive interface to a wide variety of digital and mixed-signal peripheral devices. These devices include Analog Devices AD19xx and ADAU19xx family of audio codecs, analog-to-digital converters (ADCs) and digital-to-analog converters (DACs). Two data lines, a clock, and frame sync make up the serial ports. The data lines can be programmed to either transmit or receive data and each data line has a dedicated DMA channel.

An individual full SPORT module consists of two independently configurable SPORT halves with identical functionality. Two bidirectional data lines—primary (0) and secondary (1)—are available per SPORT half and are configurable as either transmitters or receivers. Therefore, each SPORT half permits two unidirectional streams into or out of the same SPORT. This bidirectional functionality provides greater flexibility for serial communications. For full-duplex configuration, one half SPORT provides two transmit signals, while the other half SPORT provides the two receive signals. The frame sync and clock are shared.

Serial ports operate in the following six modes:

- Standard DSP serial mode
- Multichannel time division multiplexing (TDM) mode
- I²S mode
- Packed I²S mode
- Left justified mode
- Right justified mode

Asynchronous Sample Rate Converter (ASRC)

The asynchronous sample rate converter (ASRC) contains eight ASRC blocks. It is the same core in the [AD1896](#) 192 kHz stereo asynchronous sample rate converter. The ASRC provides up to 140 dB signal-to-noise ratio (SNR). The ASRC block performs synchronous or asynchronous sample rate conversion across independent stereo channels, without using internal processor resources. The ASRC blocks can also be configured to operate together to convert multichannel audio data without phase mismatches. Finally, the ASRC can clean up audio data from jittery clock sources such as the S/PDIF receiver.

S/PDIF-Compatible Digital Audio Receiver/Transmitter

The Sony/Philips Digital Interface Format (S/PDIF) is a standard audio data transfer format that allows the transfer of digital audio signals from one device to another without converting them to an analog signal. There are two S/PDIF transmit/receive

blocks on the processor. The digital audio interface carries three types of information: audio data, nonaudio data (compressed data), and timing information.

The S/PDIF interface supports one stereo channel or compressed audio streams. The S/PDIF transmitter and receiver are AES3 compliant and support the sample rate from 24 KHz to 192 KHz. The S/PDIF receiver supports professional jitter standards.

The S/PDIF receiver/transmitter has no separate DMA channels. It receives audio data in serial format and converts it into a biphasic encoded signal. The serial data input to the receiver/transmitter can be formatted as left justified, I²S, or right justified with word widths of 16, 18, 20, or 24 bits. The serial data, clock, and frame sync inputs to the S/PDIF receiver/transmitter are routed through the signal routing unit (SRU). They can come from various sources, such as the SPORTs, external pins, and the precision clock generators (PCGs), and are controlled by the SRU control registers.

Precision Clock Generators (PCG)

The precision clock generators (PCG) consist of four units: units A/B located in the DAI0 block, and units C/D located in the DAI1 block. The PCG can generate a pair of signals (clock and frame sync) derived from a clock input signal (CLKIN1-0, SCLK0, or DAI pin buffer). Each unit can also access the opposite DAI unit. All units are identical in functionality and operate independently of each other. The two signals generated by each unit are normally used as a serial bit clock/frame sync pair.

Enhanced Parallel Peripheral Interface (EPPI)

The processors provide an enhanced parallel peripheral interface (EPPI) that supports data widths up to 24 bits. The EPPI supports direct connection to TFT LCD panels, parallel ADCs and DACs, video encoders and decoders, image sensor modules, and other general-purpose peripherals.

The features supported in the EPPI module include the following:

- Programmable data length of 8 bits, 10 bits, 12 bits, 14 bits, 16 bits, 18 bits, and 24 bits per clock.
- Various framed, nonframed, and general-purpose operating modes. Frame syncs can be generated internally or can be supplied by an external device.
- ITU-656 status word error detection and correction for ITU-656 receive modes and ITU-656 preamble and status word decoding.
- Optional packing and unpacking of data to/from 32 bits from/to 8 bits, 16 bits, and 24 bits. If packing/unpacking is enabled, configure endianness to change the order of packing/unpacking of the bytes/words.
- RGB888 can be converted to RGB666 or RGB565 for transmit modes.
- Various deinterleaving/interleaving modes for receiving/transmitting 4:2:2 YCrCb data.
- Configurable LCD data enable output available on Frame Sync 3.

Universal Asynchronous Receiver/Transmitter (UART) Ports

The processors provide three full-duplex universal asynchronous receiver/transmitter (UART) ports, fully compatible with PC standard UARTs. Each UART port provides a simplified UART interface to other peripherals or hosts, supporting full-duplex, DMA supported, asynchronous transfers of serial data. A UART port includes support for five to eight data bits as well as no parity, even parity, or odd parity.

Optionally, an additional address bit can be transferred to interrupt only addressed nodes in multidrop bus (MDB) systems. A frame is terminated by a configurable number of stop bits.

The UART ports support automatic hardware flow control through the clear to send (CTS) input and request to send (RTS) output with programmable assertion first in, first out (FIFO) levels.

To help support the Local Interconnect Network (LIN) protocols, a special command causes the transmitter to queue a break command of programmable bit length into the transmit buffer. Similarly, the number of stop bits can be extended by a programmable interframe space.

Serial Peripheral Interface (SPI) Ports

The processors have three industry-standard SPI-compatible ports that allow the processors to communicate with multiple SPI-compatible devices.

The baseline SPI peripheral is a synchronous, four-wire interface consisting of two data pins, one device select pin, and a gated clock pin. The two data pins allow full-duplex operation to other SPI-compatible devices. An extra two (optional) data pins are provided to support quad SPI operation. Enhanced modes of operation, such as flow control, fast mode, and dual I/O mode (DIOM), are also supported. A direct memory access (DMA) mode allows for transferring several words with minimal central processing unit (CPU) interaction.

With a range of configurable options, the SPI ports provide a glueless hardware interface with other SPI-compatible devices in master mode, slave mode, and multimaster environments. The SPI peripheral includes programmable baud rates, clock phase, and clock polarity. The peripheral can operate in a multimaster environment by interfacing with several other devices, acting as either a master device or a slave device. In a multimaster environment, the SPI peripheral uses open-drain outputs to avoid data bus contention. The flow control features enable slow slave devices to interface with fast master devices by providing an SPI ready pin (SPI_RDY) which flexibly controls the transfers.

The baud rate and clock phase/polarities of the SPI port are programmable. The port has integrated DMA channels for both transmit and receive data streams.

Link Ports (LP)

Two 8-bit wide link ports (LP) can connect to the link ports of other DSPs or peripherals. LP are bidirectional ports that have eight data lines, an acknowledge line, and a clock line.

ADC Control Module (ACM) Interface

The ADC control module (ACM) provides an interface that synchronizes the controls between the processors and an ADC. The analog-to-digital conversions are initiated by the processors, based on external or internal events.

The ACM allows for flexible scheduling of sampling instants and provides precise sampling signals to the ADC.

The ACM synchronizes the ADC conversion process, generating the ADC controls, the ADC conversion start signal, and other signals. The actual data acquisition from the ADC is done by an internal DAI routing of the ACM with the SPORT0 block.

The processors interface directly to many ADCs without any glue logic required.

3-Phase Pulse Width Modulator (PWM) Units

The pulse width modulator (PWM) module is a flexible and programmable waveform generator. With minimal CPU intervention, the PWM generates complex waveforms for motor control, pulse coded modulation (PCM), DAC conversions, power switching, and power conversion. The PWM module has four PWM pairs capable of 3-phase PWM generation for source inverters for ac induction and dc brushless motors.

Each of the three 3-phase PWM generation units features the following:

- 16-bit center-based PWM generation unit
- Programmable PWM pulse width
- Single update mode with an option for asymmetric duty
- Programmable dead time and switching frequency
- Programmable dead time per channel
- Twos complement implementation which permits smooth transition to full on and full off states
- Dedicated asynchronous PWM shutdown signal

Ethernet Media Access Controller (EMAC)

The processor features two ethernet media access controllers (EMACs): 10/100 Ethernet and 10/100/1000/AVB Ethernet with precision time protocol IEEE 1588.

The processors can directly connect to a network through embedded fast EMAC that supports 10-BaseT (10 Mb/sec), 100-BaseT (100 Mb/sec) and 1000-BaseT (1 Gb/sec) operations. The 10/100 EMAC peripheral on the processors is fully compliant to the IEEE 802.3-2002 standard. The peripheral provides programmable features designed to minimize supervision, bus use, or message processing by the rest of the processor system.

Some standard features of the EMAC are as follows:

- Support and RMI/ RGMII protocols for external PHYs
- Full-duplex and half-duplex modes
- Media access management (in half-duplex operation)
- Flow control
- Station management, including the generation of MDC/MDIO frames for read/write access to PHY registers

ADSP-SC582/SC583/SC584/SC587/SC589/ADSP-21583/21584/21587

Some advanced features of the EMAC are as follows:

- Automatic checksum computation of IP header and IP payload fields of receive frames
- Independent 32-bit descriptor driven receive and transmit DMA channels
- Frame status delivery to memory through DMA, including frame completion semaphores for efficient buffer queue management in software
- Transmit DMA support for separate descriptors for MAC header and payload fields to eliminate buffer copy operations
- Convenient frame alignment modes
- 47 MAC management statistics counters with selectable clear on read behavior and programmable interrupts on half maximum value
- Advanced power management
- Magic packet detection and wakeup frame filtering
- Support for 802.3Q tagged VLAN frames
- Programmable MDC clock rate and preamble suppression

Audio Video Bridging (AVB) Support (10/100/1000 EMAC Only)

The 10/100/1000 EMAC supports the following audio video (AVB) features:

- Separate channels or queues for AV data transfer in 100 Mbps and 1000 Mbps modes
- IEEE 802.1-Qav specified credit-based shaper (CBS) algorithm for the additional transmit channels
- Configuring up to two additional channels (Channel 1 and Channel 2) on the transmit and receive paths for AV traffic. Channel 0 is available by default and carries the legacy best effort Ethernet traffic on the transmit side.
- Separate DMA, transmit and receive FIFO for AVB latency class
- Programmable control to route received VLAN tagged non AV packets to channels or queues

Precision Time Protocol (PTP) IEEE 1588 Support

The IEEE 1588 standard is a precision clock synchronization protocol for networked measurement and control systems. The processors include hardware support for IEEE 1588 with an integrated precision time protocol synchronization engine (PTP_TSYNC).

This engine provides hardware assisted time stamping to improve the accuracy of clock synchronization between PTP nodes. The main features of the engine are as follows:

- Support for both IEEE 1588-2002 and IEEE 1588-2008 protocol standards
- Hardware assisted time stamping capable of up to 12.5 ns resolution
- Lock adjustment

- Automatic detection of IPv4 and IPv6 packets, as well as PTP messages
- Multiple input clock sources (SCLK0, RGMII, RMII, RMII clock, and external clock)
- Programmable pulse per second (PPS) output
- Auxiliary snapshot to time stamp external events

Controller Area Network (CAN)

There are two controller area network (CAN) modules. A CAN controller implements the CAN 2.0B (active) protocol. This protocol is an asynchronous communications protocol used in both industrial and automotive control systems. The CAN protocol is well suited for control applications due to the capability to communicate reliably over a network. This is because the protocol incorporates CRC checking, message error tracking, and fault node confinement.

The CAN controller offers the following features:

- 32 mailboxes (8 receive only, 8 transmit only, 16 configurable for receive or transmit)
- Dedicated acceptance masks for each mailbox
- Additional data filtering on the first two bytes
- Support for both the standard (11-bit) and extended (29-bit) identifier (ID) message formats
- Support for remote frames
- Active or passive network support
- Interrupts, including transmit and receive complete, error, and global

An additional crystal is not required to supply the CAN clock because it is derived from a system clock through a programmable divider.

Timers

The processors include several timers that are described in the following sections.

General-Purpose (GP) Timers (TIMER)

There is one general-purpose (GP) timer unit, providing eight general-purpose programmable timers. Each timer has an external pin that can be configured either as PWM or timer output, as an input to clock the timer, or as a mechanism for measuring pulse widths and periods of external events. These timers can be synchronized to an external clock input on the TM_TMR[n] pins, an external TM_CLK input pin, or to the internal SCLK0.

These timer units can be used in conjunction with the UARTs and the CAN controller to measure the width of the pulses in the data stream to provide a software autobaud detect function for the respective serial channels.

The GP timers can generate interrupts to the processor core, providing periodic events for synchronization to either the system clock or to external signals. Timer events can also trigger other peripherals via the TRU (for instance, to signal a fault). Each timer can also be started and/or stopped by any TRU master without core intervention.

ADSP-SC582/SC583/SC584/SC587/SC589/ADSP-21583/21584/21587

Watchdog Timer (WDT)

Two on-chip software watchdog timers (WDT) can be used by the Arm Cortex-A5 and/or SHARC+ cores. A software watchdog can improve system availability by forcing the processors to a known state, via a general-purpose interrupt, or a fault, if the timer expires before being reset by software.

The programmer initializes the count value of the timer, enables the appropriate interrupt, then enables the timer. Thereafter, the software must reload the counter before it counts down to zero from the programmed value, protecting the system from remaining in an unknown state where software that normally resets the timer stops running due to an external noise condition or software error.

General-Purpose Counters (CNT)

A 32-bit counter (CNT) is provided that can operate in general-purpose up/down count modes and can sense 2-bit quadrature or binary codes as typically emitted by industrial drives or manual thumbwheels. Count direction is either controlled by a level-sensitive input pin or by two edge detectors.

A third counter input can provide flexible zero marker support and can input the push button signal of thumbwheel devices. All three CNT0 pins have a programmable debouncing circuit.

Internal signals forwarded to a GP timer enable this timer to measure the intervals between count events. Boundary registers enable auto-zero operation or simple system warning by interrupts when programmed count values are exceeded.

PCI Express (PCIe)

A PCI express interface (PCIe) is available on some product variants (see [Table 2](#) and [Table 3](#)). This single, bidirectional lane can be configured to be either a root complex (RC) or end point (EP) system. The PCIe interface has the following features:

- Designed to be compliant with the *PCI Express Base Specification 3.0*
- Support for transfers at either 2.5 Gbps (Gen 1) or 5.0 Gbps (Gen 2) in each direction
- Support for 8b/10b encode and decode
- Lane reversal and lane polarity inversion
- Flow control of data in both the transmit and receive directions
- Support for removal of corrupted packets for error detection and recovery
- Maximum transaction payload of 256 bytes

Housekeeping Analog-to-Digital Converter (HADAC)

The housekeeping analog-to-digital converter (HADAC) provides a general-purpose, multichannel successive approximation ADC. It supports the following set of features:

- 12-bit ADC core with built in sample-and-hold.
- 8 single-ended input channels that can be extended to 15 channels by adding an external channel multiplexer.
- Throughput rates up to 1 MSPS.

- Single external reference with analog inputs between 0 V and 3.3 V.
- Selectable ADC clock frequency including the ability to program a prescaler.
- Adaptable conversion type; allows single or continuous conversion with option of autoscan.
- Autosequencing capability with up to 15 autoconversions in a single session. Each conversion can be programmed to select 1 to 15 input channels.
- 16 data registers (individually addressable) to store conversion values.

USB 2.0 On the Go (OTG) Dual-Role Device Controller

There are two USB modules + PHY. USB0 supports HS/FS/LS USB 2.0 on the go (OTG) and USB1 supports HS/FS USB 2.0 only and can be programmed to be a host or device.

The USB 2.0 OTG dual-role device controller provides a low cost connectivity solution in industrial applications, as well as consumer mobile devices such as cell phones, digital still cameras, and MP3 players. The USB 2.0 controller allows these devices to transfer data using a point to point USB connection without the need for a PC host. The module can operate in a traditional USB peripheral only mode as well as the host mode presented in the OTG supplement to the USB 2.0 specification.

The USB clock is provided through a dedicated external crystal or crystal oscillator.

The USB OTG dual-role device controller includes a PLL with programmable multipliers to generate the necessary internal clocking frequency for the USB.

Media Local Bus (Media LB)

The automotive model has a Media LB (MLB) slave interface that allows the processors to function as a media local bus device. It includes support for both 3-pin and 6-pin media local bus protocols. The MLB 3-pin configuration supports speeds up to $1024 \times FS$. The MLB 6-pin configuration supports a speed of $2048 \times FS$. The MLB also supports up to 64 logical channels with up to 468 bytes of data per MLB frame.

The MLB interface supports MOST25, MOST50, and MOST150 data rates and operates in slave mode only.

2-Wire Controller Interface (TWI)

The processors include three 2-wire interface (TWI) modules that provide a simple exchange method of control data between multiple devices. The TWI module is compatible with the widely used I²C bus standard. The TWI module offers the capabilities of simultaneous master and slave operation and support for both 7-bit addressing and multimedia data arbitration. The TWI interface utilizes two pins for transferring clock (TWI_SCL) and data (TWI_SDA) and supports the protocol at speeds up to 400 kb/sec. The TWI interface pins are compatible with 5 V logic levels.

Additionally, the TWI module is fully compatible with serial camera control bus (SCCB) functionality for easier control of various CMOS camera sensor devices.

General-Purpose I/O (GPIO)

Each general-purpose port pin can be individually controlled by manipulating the port control, status, and interrupt registers:

- GPIO direction control register specifies the direction of each individual GPIO pin as input or output.
- GPIO control and status registers have a write one to modify mechanism that allows any combination of individual GPIO pins to be modified in a single instruction, without affecting the level of any other GPIO pins.
- GPIO interrupt mask registers allow each individual GPIO pin to function as an interrupt to the processors. GPIO pins defined as inputs can be configured to generate hardware interrupts, while output pins can be triggered by software interrupts.
- GPIO interrupt sensitivity registers specify whether individual pins are level or edge sensitive and specify, if edge sensitive, whether the rising edge or both the rising and falling edges of the signal are significant.

Pin Interrupts

Every port pin on the processors can request interrupts in either an edge sensitive or a level sensitive manner with programmable polarity. Interrupt functionality is decoupled from GPIO operation. Six system-level interrupt channels (PINT0–PINT5) are reserved for this purpose. Each of these interrupt channels can manage up to 32 interrupt pins. The assignment from pin to interrupt is not performed on a pin by pin basis. Rather, groups of eight pins (half ports) can be flexibly assigned to interrupt channels.

Every pin interrupt channel features a special set of 32-bit memory-mapped registers that enable half-port assignment and interrupt management. This includes masking, identification, and clearing of requests. These registers also enable access to the respective pin states and use of the interrupt latches, regardless of whether the interrupt is masked or not. Most control registers feature multiple MMR address entries to write-one-to-set or write-one-to-clear them individually.

Mobile Storage Interface (MSI)

The mobile storage interface (MSI) controller acts as the host interface for multimedia cards (MMC), secure digital memory cards (SD), and secure digital input/output cards (SDIO). The MSI controller has the following features:

- Support for a single MMC, SD memory, and SDIO card
- Support for 1-bit and 4-bit SD modes
- Support for 1-bit, 4-bit, and 8-bit MMC modes
- Support for eMMC 4.3 embedded NAND flash devices
- An eleven-signal external interface with clock, command, optional interrupt, and up to eight data lines
- Integrated DMA controller
- Card interface clock generation in the clock distribution unit (CDU)
- SDIO interrupt and read wait features

SYSTEM ACCELERATION

The following sections describe the system acceleration blocks of the ADSP-SC58x/ADSP-2158x processors.

FFT/IFFT Accelerator

A high performance FFT/IFFT accelerator is available to improve the overall floating-point computation power of the ADSP-SC58x/ADSP-2158x processors.

The following features are available to improve the overall performance of the FFT/IFFT accelerator:

- Support for the IEEE-754/854 single-precision floating-point data format.
- Automatic twiddle factor generation to reduce system bandwidth.
- Support for a vector complex multiply for windowing and frequency domain filtering.
- Ability to pipeline the data flow. This allows the accelerator to bring in a new data set while the current data set is processed and the previous data set is sent out to memory. This can provide a significant system level performance improvement.
- Ability to output the result as the magnitude squared of the complex samples.
- Dedicated, high speed DMA controller with 64-bit buses that can read and write data from any memory space.

The FFT/IFFT accelerator can run concurrently with the other accelerators on the processor.

Finite Impulse Response (FIR) Accelerator

The finite impulse response (FIR) accelerator consists of a 1024 word coefficient memory, a 1024 word deep delay line for the data, and four MAC units. A controller manages the accelerator. The FIR accelerator runs at the peripheral clock frequency. The FIR accelerator can access all memory spaces and can run concurrently with the other accelerators on the processor.

Infinite Impulse Response (IIR) Accelerator

The infinite impulse response (IIR) accelerator consists of a 1440 word coefficient memory for storage of biquad coefficients, a data memory for storing the intermediate data, and one MAC unit. A controller manages the accelerator. The IIR accelerator runs at the peripheral clock frequency. The IIR accelerator can access all memory spaces and run concurrently with the other accelerators on the processor.

Harmonic Analysis Engine (HAE)

The harmonic analysis engine (HAE) block receives 8 kHz input samples from two source signals whose frequencies are between 45 Hz and 65 Hz. The HAE processes the input samples and produces output results. The output results consist of power quality measurements of the fundamental and up to 12 additional harmonics.

Sinus Cardinalis (SINC) Filter

The sinus cardinalis (SINC) filter module processes four bit streams using a pair of configurable SINC filters for each bit stream. The purpose of the primary SINC filter of each pair is to produce the filtered and decimated output for the pair. The output can decimate any integer rate between 8 and 256 times lower than the input rate. Greater decimation allows greater removal of noise, and, therefore, greater effective number of bits (ENOB).

Optional additional filtering outside the SINC module can further increase ENOB. The primary SINC filter output is accessible through transfer to processor memory, or to another peripheral, via DMA.

Each of the four channels is also provided with a low latency secondary filter with programmable positive and negative over-range detection comparators. These limit detection events can interrupt the core, generate a trigger, or signal a system fault.

Digital Transmission Content Protection (DTCP)

Contact Analog Devices for more information on DTCP.

SYSTEM DESIGN

The following sections provide an introduction to system design features and power supply issues.

Clock Management

The processors provide three operating modes, each with a different performance and power profile. Control of clocking to each of the processor peripherals reduces power consumption. The processors do not support any low power operation modes. Control of clocking to each of the processor peripherals can reduce the power consumption.

Reset Control Unit (RCU)

Reset is the initial state of the whole processor, or the core, and is the result of a hardware or software triggered event. In this state, all control registers are set to default values and functional units are idle. Exiting a full system reset starts with the core ready to boot.

The reset control unit (RCU) controls how all the functional units enter and exit reset. Differences in functional requirements and clocking constraints define how reset signals are generated. Programs must guarantee that none of the reset functions put the system into an undefined state or causes resources to stall. This is particularly important when the core resets (programs must ensure that there is no pending system activity involving the core when it is reset).

From a system perspective, reset is defined by both the reset target and the reset source.

The reset target is defined as the following:

- System reset—all functional units except the RCU are set to default states.
- Hardware reset—all functional units are set to default states without exception. History is lost.
- Core only reset— affects the core only. When in reset state, the core is not accessed by any bus master.

The reset source is defined as the following:

- System reset—can be triggered by software (writing to the RCU_CTL register) or by another functional unit such as the dynamic power management (DPM) unit or any of the SEC, TRU, or emulator inputs.
- Hardware reset—the $\overline{\text{SYS_HWRST}}$ input signal asserts active (pulled down).
- Core only reset—affects only the core. The core is not accessed by any bus master when in reset state.
- Trigger request (peripheral).

Real-Time Clock (RTC)

The real-time clock (RTC) provides a robust set of digital watch features, including current time, stopwatch, and alarm. The RTC is clocked by a 32.768 kHz crystal external to the processor. Connect the RTC0_CLKIN and RTC0_XTAL pins with external components as shown in Figure 6.

The RTC peripheral has dedicated power supply pins so it can remain powered up and clocked even when the remainder of the processor is in a low power state. The RTC provides several programmable interrupt options, including interrupt per second, minute, hour, or day clock ticks; interrupt on programmable stopwatch countdown; or interrupt at a programmed alarm time.

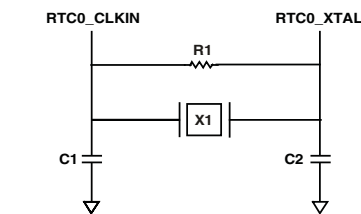

NOTE: C1 AND C2 ARE SPECIFIC TO CRYSTAL SPECIFIED FOR X1. CONTACT CRYSTAL MANUFACTURER FOR DETAILS.

Figure 6. External Components for RTC

The 32.768 kHz input clock frequency is divided down to a 1 Hz signal by a prescaler. The counter function of the timer consists of four counters: a 60 second counter, a 60 minute counter, a 24 hour counter, and a 32,768 day counter. When the alarm interrupt is enabled, the alarm function generates an interrupt when the output of the timer matches the programmed value in the alarm control register (RTC_ALARM). There are two alarms: a time of day and a day and time of that day.

ADSP-SC582/SC583/SC584/SC587/SC589/ADSP-21583/21584/21587

The stopwatch function counts down from a programmed value, with 1 sec resolution. When the stopwatch interrupt is enabled and the counter underflows, an interrupt is generated.

Clock Generation Unit (CGU)

The ADSP-SC58x/ADSP-2158x processors support two independent PLLs. Each PLL is part of a clock generation unit (CGU); see Figure 8. Each CGU can be either driven externally by the same clock source or each can be driven by separate sources. This provides flexibility in determining the internal clocking frequencies for each clock domain.

Frequencies generated by each CGU are derived from a common multiplier with different divider values available for each output.

The CGU generates all on-chip clocks and synchronization signals. Multiplication factors are programmed to define the PLLCLK frequency.

Programmable values divide the PLLCLK frequency to generate the core clock (CCLK), the system clocks, the DDR1/DDR2/DDR3 clock (DCLK), and the output clock (OCLK). For more information on clocking, see the [ADSP-SC58x/ADSP-2158x SHARC+ Processor Hardware Reference](#).

Writing to the CGU control registers does not affect the behavior of the PLL immediately. Registers are first programmed with a new value and the PLL logic executes the changes so it transitions smoothly from the current conditions to the new conditions.

System Crystal Oscillator and USB Crystal Oscillator

The processor can be clocked by an external crystal (see Figure 7), a sine wave input, or a buffered, shaped clock derived from an external clock oscillator. If using an external clock, it should be a TTL-compatible signal and must not be halted, changed, or operated below the specified frequency during normal operation. This signal is connected to the SYS_CLKINx pin and the USB_CLKIN pin of the processor. When using an external clock, the SYS_XTALx pin and the USB_XTAL pin must be left unconnected. Alternatively, because the processor includes an on-chip oscillator circuit, an external crystal can be used.

For fundamental frequency operation, use the circuit shown in Figure 7. A parallel resonant, fundamental frequency, micro-processor grade crystal is connected across the SYS_CLKINx pin and the SYS_XTALx pin. The on-chip resistance between the SYS_CLKINx pin and the SYS_XTALx pin is in the 500 k Ω range. Further parallel resistors are typically not recommended.

The two capacitors and the series resistor, shown in Figure 7, fine tune phase and amplitude of the sine frequency. The capacitor and resistor values shown in Figure 7 are typical values only. The capacitor values are dependent upon the load capacitance recommendations of the crystal manufacturer and the physical layout of the printed circuit board (PCB). The resistor value depends on the drive level specified by the crystal manufacturer. The user must verify the customized values based on careful investigations on multiple devices over the required temperature range.

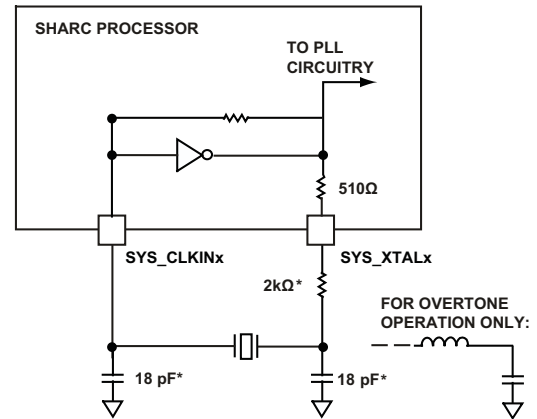

NOTE: VALUES MARKED WITH * MUST BE CUSTOMIZED, DEPENDING ON THE CRYSTAL AND LAYOUT. ANALYZE CAREFULLY. FOR FREQUENCIES ABOVE 33 MHz, THE SUGGESTED CAPACITOR VALUE OF 18 pF MUST BE TREATED AS A MAXIMUM.

Figure 7. External Crystal Connection

A third overtone crystal can be used for frequencies above 25 MHz. The circuit is then modified to ensure crystal operation only at the third overtone by adding a tuned inductor circuit, shown in Figure 7. A design procedure for the third overtone operation is discussed in detail in [Using Third Overtone Crystals with the ADSP-218x DSP \(EE-168\)](#). The same recommendations can be used for the USB crystal oscillator.

Clock Distribution Unit (CDU)

The two CGUs each provide outputs which feed a clock distribution unit (CDU). The clock outputs CLKO0–CLKO9 are connected to various targets. For more information, refer to the [ADSP-SC58x/ADSP-2158x SHARC+ Processor Hardware Reference](#).

Power-Up

SYS_XTALx oscillations (SYS_CLKINx) start when power is applied to the VDD_EXT pins. The rising edge of SYS_HWRST starts on-chip PLL locking (PLL lock counter). The deassertion must apply only if all voltage supplies and SYS_CLKINx oscillations are valid (refer to the [Power-Up Reset Timing](#) section).

Clock Out/External Clock

The SYS_CLKOUT output pin has programmable options to output divided-down versions of the on-chip clocks. By default, the SYS_CLKOUT pin drives a buffered version of the SYS_CLKIN0 input. Refer to the [ADSP-SC58x/ADSP-2158x SHARC+ Processor Hardware Reference](#) to change the default mapping of clocks.

Booting

The processors have several mechanisms for automatically loading internal and external memory after a reset. The boot mode is defined by the SYS_BMODE[n] input pins. There are two

ADSP-SC582/SC583/SC584/SC587/SC589/ADSP-21583/21584/21587

categories of boot modes. In master boot mode, the processors actively load data from serial memories. In slave boot modes, the processors receive data from external host devices.

The boot modes are shown in Table 9. These modes are implemented by the SYS_BMODE[n] bits of the reset configuration register and are sampled during power-on resets and software initiated resets.

In the ADSP-SC58x processors, the Arm Cortex-A5 (Core 0) controls the boot process, including loading all internal and external memory. Likewise, in the ADSP-2158x processors, the SHARC+ (Core 1) controls the boot function. The option for secure boot is available on all models.

Table 9. Boot Modes

SYS_BMODE[n] Setting	Boot Mode
000	No boot
001	SPI2 master
010	SPI2 slave
011	Reserved
100	Reserved
101	Reserved
110	Link0 slave
111	UART0 slave

Thermal Monitoring Unit (TMU)

The thermal monitoring unit (TMU) provides on-chip temperature measurement which is important in applications that require substantial power consumption. The TMU is integrated into the processor die and digital infrastructure using an MMR-based system access to measure the die temperature variations in real-time.

TMU features include the following:

- On-chip temperature sensing
- Programmable over temperature and under temperature limits
- Programmable conversion rate
- Averaging feature available

Power Supplies

The processors have separate power supply connections for:

- Internal (VDD_INT)
- External (VDD_EXT)
- USB (VDD_USB)
- HADC/TMU (VDD_HADC)
- RTC (VDD_RTC)
- DMC (VDD_DMC)
- PCIe (VDD_PCIE, VDD_PCIE_TX and VDD_PCIE_RX)

All power supplies must meet the specifications provided in the [Operating Conditions](#) section. All external supply pins must be connected to the same power supply.

Power Management

As shown in Table 10, the processors support four different power domains, which maximizes flexibility while maintaining compliance with industry standards and conventions. There are no sequencing requirements for the various power domains, but all domains must be powered according to the appropriate specifications (see the [Specifications](#) section for processor operating conditions). If the feature or the peripheral is not used, refer to Table 27.)

Table 10. Power Domains

Power Domain	V _{DD} Range
All internal logic	V _{DD_INT}
DDR3/DDR2/LPDDR	V _{DD_DMC}
USB	V _{DD_USB}
HADC/TMU	V _{DD_HADC}
RTC	V _{DD_RTC}
PCIe_TX	V _{DD_PCIE_TX}
PCIe_RX	V _{DD_PCIE_RX}
PCIe	V _{DD_PCIE}
All other I/O (includes SYS, JTAG, and port pins)	V _{DD_EXT}

The power dissipated by the processors is largely a function of the clock frequency and the square of the operating voltage. For example, reducing the clock frequency by 25% results in a 25% reduction in dynamic power dissipation.

Target Board JTAG Emulator Connector

The Analog Devices DSP tools product line of JTAG emulators uses the IEEE 1149.1 JTAG test access port of the processors to monitor and control the target board processor during emulation. The Analog Devices DSP tools product line of JTAG emulators provides emulation at full processor speed, allowing inspection and modification of memory, registers, and processor stacks. The processor JTAG interface ensures the emulator does not affect target system loading or timing.

For information on JTAG emulator operation, see the appropriate emulator hardware user's guide at [SHARC Processors Software and Tools](#).

SYSTEM DEBUG

The processors include various features that allow easy system debug. These are described in the following sections.

System Watchpoint Unit (SWU)

The system watchpoint unit (SWU) is a single module that connects to a single system bus and provides transaction monitoring. One SWU is attached to the bus going to each system slave. The SWU provides ports for all system bus address channel signals. Each SWU contains four match groups of registers with associated hardware. These four SWU match groups operate independently but share common event (for example, interrupt and trigger) outputs.

Debug Access Port (DAP)

Debug access port (DAP) provides IEEE 1149.1 JTAG interface support through the JTAG debug. The DAP provides an optional instrumentation trace for both the core and system. It provides a trace stream that conforms to *MIPI System Trace Protocol version 2 (STPv2)*.

DEVELOPMENT TOOLS

Analog Devices supports its processors with a complete line of software and hardware development tools, including an integrated development environment (CrossCore[®] Embedded Studio), evaluation products, emulators, and a variety of software add-ins.

Integrated Development Environments (IDEs)

For C/C++ software writing and editing, code generation, and debug support, Analog Devices offers the CrossCore Embedded Studio integrated development environment (IDE).

CrossCore Embedded Studio is based on the Eclipse framework. Supporting most Analog Devices processor families, it is the IDE of choice for processors, including multicore devices. CrossCore Embedded Studio seamlessly integrates available software add-ins to support real-time operating systems, file systems, TCP/IP stacks, USB stacks, algorithmic software modules, and evaluation hardware board support packages. For more information, visit www.analog.com/cces.

EZ-KIT Lite Evaluation Board

For processor evaluation, Analog Devices provides a wide range of EZ-KIT Lite[®] evaluation boards. Including the processor and key peripherals, the evaluation board also supports on-chip emulation capabilities and other evaluation and development features. Various EZ-Extenders[®] are also available, which are daughter cards that deliver additional specialized functionality, including audio and video processing. For more information visit www.analog.com.

EZ-KIT Lite Evaluation Kits

For a cost-effective way to learn more about developing with Analog Devices processors, Analog Devices offer a range of EZ-KIT Lite evaluation kits. Each evaluation kit includes an EZ-KIT Lite evaluation board, directions for downloading an evaluation version of the available IDE(s), a USB cable, and a power supply. The USB controller on the EZ-KIT Lite board connects to the USB port of the user PC, enabling the chosen IDE evaluation suite to emulate the on-board processor in-circuit.

This permits users to download, execute, and debug programs for the EZ-KIT Lite system. It also supports in circuit programming of the on-board Flash device to store user specific boot code, enabling standalone operation. With the full version of CrossCore Embedded Studio installed (sold separately), engineers can develop software for supported EZ-KITs or any custom system utilizing supported Analog Devices processors.

Software Add-Ins for CrossCore Embedded Studio

Analog Devices offers software add-ins which seamlessly integrate with CrossCore Embedded Studio to extend the capabilities and reduce development time. Add-ins include board support packages for evaluation hardware, various middleware packages, and algorithmic modules. Documentation, help, configuration dialogs, and coding examples present in these add-ins are viewable through the CrossCore Embedded Studio IDE once the add-in is installed.

Board Support Packages for Evaluation Hardware

Software support for the EZ-KIT Lite evaluation boards and EZ-Extender daughter cards is provided by software add-ins called board support packages (BSPs). The BSPs contain the required drivers, pertinent release notes, and select example code for the given evaluation hardware. A download link for a specific BSP is located on the web page for the associated EZ-KIT or EZ-Extender product.

Middleware Packages

Analog Devices offers middleware add-ins such as real-time operating systems, file systems, USB stacks, and TCP/IP stacks. For more information, see the following web pages:

- www.analog.com/ucos2
- www.analog.com/ucos3
- www.analog.com/ucfs
- www.analog.com/ucusb
- www.analog.com/ucusbh
- www.analog.com/lwip

Algorithmic Modules

To speed development, Analog Devices offers add-ins that perform popular audio and video processing algorithms. These are available for use with CrossCore Embedded Studio. For more information visit www.analog.com.

Designing an Emulator-Compatible DSP Board (Target)

For embedded system test and debug, Analog Devices provides a family of emulators. On each JTAG DSP, Analog Devices supplies an IEEE 1149.1 JTAG test access port (TAP). In-circuit emulation is facilitated by use of this JTAG interface. The emulator accesses the internal features of the processor via the TAP, allowing the developer to load code, set breakpoints, and view variables, memory, and registers.

The processor must be halted to send data and commands, but once an operation is completed by the emulator, the DSP system is set to run at full speed with no impact on system timing. The emulators require the target board to include a header that supports connection of the JTAG port of the DSP to the emulator.

For details on target board design issues including mechanical layout, single processor connections, signal buffering, signal termination, and emulator pod logic, see [Analog Devices JTAG Emulation Technical Reference \(EE-68\)](#).

ADDITIONAL INFORMATION

This data sheet provides a general overview of the ADSP-SC58x/ADSP-2158x architecture and functionality. For detailed information on the core architecture and instruction set, refer to the [SHARC+ Core Programming Reference](#).

RELATED SIGNAL CHAINS

A signal chain is a series of signal-conditioning electronic components that receive input (data acquired from sampling either real-time phenomena or from stored data) in tandem, with the output of one portion of the chain supplying input to the next. Signal chains are often used in signal processing applications to gather and process data or to apply system controls based on analysis of real-time phenomena.

Analog Devices eases signal processing system development by providing signal processing components that are designed to work together well. A tool for viewing relationships between specific applications and related components is available on the www.analog.com website.

The application signal chains page in the Circuits from the Lab[®] site (www.analog.com/circuits) provides the following:

- Graphical circuit block diagram presentation of signal chains for a variety of circuit types and applications
- Drill down links for components in each chain to selection guides and application information
- Reference designs applying best practice design techniques

ADSP-SC582/SC583/SC584/SC587/SC589/ADSP-21583/21584/21587

ADSP-SC58x/ADSP-2158x DETAILED SIGNAL DESCRIPTIONS

Table 11 provides a detailed description of each pin.

Table 11. ADSP-SC58x/ADSP-2158x Detailed Signal Descriptions

Signal Name	Direction	Description
ACM_A[n]	Output	ADC Control Signals. Function varies by mode.
ACM_T[n]	Input	External Trigger n. Input for external trigger events.
C1_FLG[n]	InOut	SHARC+ Core 1 Flag Pin.
C2_FLG[n]	InOut	SHARC+ Core 2 Flag Pin.
CAN_RX	Input	Receive. Typically an external CAN transceiver RX output.
CAN_TX	Output	Transmit. Typically an external CAN transceiver TX input.
CNT_DG	Input	Count Down and Gate. Depending on the mode of operation, this input acts either as a count down signal or a gate signal. Count down—this input causes the GP counter to decrement. Gate—stops the GP counter from incrementing or decrementing.
CNT_UD	Input	Count Up and Direction. Depending on the mode of operation, this input acts either as a count up signal or a direction signal. Count up—this input causes the GP counter to increment. Direction—selects whether the GP counter is incrementing or decrementing.
CNT_ZM	Input	Count Zero Marker. Input that connects to the zero marker output of a rotary device or detects the pressing of a pushbutton.
DAI_PIN[nn]	InOut	Pin n. The digital applications interfaces (DAI0 and DAI1) connect various peripherals to any of the DAI0_PINnn and DAI1_PINnn pins. Programs make these connections using the signal routing unit (SRU). Both DAI units are symmetric. The shared DAIx__PIN03 and DAIx_PIN04 pins allow routing between both DAI units.
DMC_A[nn]	Output	Address n. Address bus.
DMC_BA[n]	Output	Bank Address n. Defines which internal bank an activate, read, write, or precharge command is applied to on the dynamic memory. Bank Address n also defines which mode registers (MR, EMR, EMR2, and/or EMR3) load during the load mode register command.
$\overline{\text{DMC_CAS}}$	Output	Column Address Strobe. Defines the operation for external dynamic memory to perform in conjunction with other DMC command signals. Connect to the CAS input of dynamic memory.
DMC_CK	Output	Clock. Outputs DCLK to external dynamic memory.
DMC_CKE	Output	Clock Enable. Active high clock enables. Connects to the dynamic memory's CKE input.
$\overline{\text{DMC_CK}}$	Output	Clock (Complement). Complement of DMC_CK.
DMC_CS[n]	Output	Chip Select n. Commands are recognized by the memory only when this signal is asserted.
DMC_DQ[nn]	InOut	Data n. Bidirectional data bus.
DMC_LDM	Output	Data Mask for Lower Byte. Mask for DMC_DQ07:DMC_DQ00 write data when driven high. Sampled on both edges of the data strobe by the dynamic memory.
DMC_LDQS	InOut	Data Strobe for Lower Byte. DMC_DQ07:DMC_DQ00 data strobe. Output with write data. Input with read data. Can be single-ended or differential depending on register settings.
$\overline{\text{DMC_LDQS}}$	InOut	Data Strobe for Lower Byte (Complement). Complement of LDQS. Not used in single-ended mode.
DMC_ODT	Output	On-Die Termination. Enables dynamic memory termination resistances when driven high (assuming the memory is properly configured).
$\overline{\text{DMC_RAS}}$	Output	Row Address Strobe. Defines the operation for external dynamic memory to perform in conjunction with other DMC command signals. Connect to the RAS input of dynamic memory.
$\overline{\text{DMC_RESET}}$	Output	Reset (DDR3 Only).
DMC_RZQ	InOut	External Calibration Resistor Connection.
DMC_UDM	Output	Data Mask for Upper Byte. Mask for DMC_DQ15:DMC_DQ08 write data when driven high. Sampled on both edges of the data strobe by the dynamic memory.
DMC_UDQS	InOut	Data Strobe for Upper Byte. DMC_DQ15:DMC_DQ08 data strobe. Output with write data. Input with read data. Not used in single-ended mode.

ADSP-SC582/SC583/SC584/SC587/SC589/ADSP-21583/21584/21587

Table 11. ADSP-SC58x/ADSP-2158x Detailed Signal Descriptions (Continued)

Signal Name	Direction	Description
$\overline{\text{DMC_UDQS}}$	InOut	Data Strobe for Upper Byte (Complement). Complement of $\overline{\text{UDQS}}$. Not used in single-ended mode.
DMC_VREF	Input	Voltage Reference. Externally driven to $\text{VDD_DMC}/2$. Applies to DMC0_VREF and DMC1_VREF pins.
$\overline{\text{DMC_WE}}$	Output	Write Enable. Defines the operation for external dynamic memory to perform in conjunction with other DMC command signals. Connect to the WE input of dynamic memory.
ETH_CRS	Input	Carrier Sense/RMII Receive Data Valid. Multiplexed on alternate clock cycles. CRS— asserted by the PHY when either the transmit or receive medium is not idle. Deasserted when both are idle. RXDV—asserted by the PHY when the data on RXDn is valid.
ETH_MDC	Output	Management Channel Clock. Clocks the MDC input of the PHY for RMII/RGMII.
ETH_MDIO	InOut	Management Channel Serial Data. Bidirectional data bus for PHY control for RMII/RGMII.
ETH_PTPAUXIN[n]	Input	PTP Auxiliary Trigger Input. Assert this signal to take an auxiliary snapshot of the time and store it in the auxiliary time stamp FIFO.
ETH_PTPCLKIN[n]	Input	PTP Clock Input. Optional external PTP clock input.
ETH_PTPPPS[n]	Output	PTP Pulse Per Second Output. When the advanced time stamp feature enables, this signal is asserted based on the PPS mode selected. Otherwise, PTPPPS is asserted every time the seconds counter is incremented.
ETH_REFCLK	Input	Reference Clock. Externally supplied Ethernet clock.
ETH_RXCLK_REFCLK	Input	RXCLK (10/100/1000) or REFCLK (10/100).
ETH_RXCTL_CRS	Input	RXCTL (10/100/1000) or CRS (10/100).
ETH_RXD[n]	Input	Receive Data n. Receive data bus.
ETH_TXCLK	Output	Transmit Clock.
ETH_TXCTL_TXEN	Output	TXCTL (10/100/1000) or TXEN (10/100).
ETH_TXD[n]	Output	Transmit Data n. Transmits data bus.
ETH_TXEN	Output	Transmit Enable. When asserted, signal indicates the data on TXDn is valid.
HADC_EOC_DOUT	Output	End of Conversion/Serial Data Out. Transitions high for one cycle of the HADC internal clock at the end of every conversion. Alternatively, HADC serial data out can be seen by setting the appropriate bit in HADC_CTL.
HADC_MUX[n]	Input	Controls to External Multiplexer. Allows additional input channels when connected to an external multiplexer.
HADC_VIN[n]	Input	Analog Input at Channel n. Analog voltage inputs for digital conversion.
HADC_VREFN	Input	Ground Reference for ADC. Connect to an external voltage reference that meets data sheet specifications.
HADC_VREFP	Input	External Reference for ADC. Connect to an external voltage reference that meets data sheet specifications.
JTG_TCK	Input	JTAG Clock. JTAG test access port clock.
JTG_TDI	Input	JTAG Serial Data In. JTAG test access port data input.
JTG_TDO	Output	JTAG Serial Data Out. JTAG test access port data output.
JTG_TMS	Input	JTAG Mode Select. JTAG test access port mode select.
$\overline{\text{JTG_TRST}}$	Input	JTAG Reset. JTAG test access port reset.
LP_ACK	InOut	Acknowledge. Provides handshaking. When the link port is configured as a receiver, ACK is an output. When the link port is configured as a transmitter, ACK is an input.
LP_CLK	InOut	Clock. When the link port is configured as a receiver, CLK is an input. When the link port is configured as a transmitter, CLK is an output.
LP_D[n]	InOut	Data n. Data bus. Input when receiving, output when transmitting.
MLB_CLKN	Input	Differential Clock (-).
MLB_CLKP	Input	Differential Clock (+).
MLB_DATN	InOut	Differential Data (-).
MLB_DATP	InOut	Differential Data (+).
MLB_SIGN	InOut	Differential Signal (-).

ADSP-SC582/SC583/SC584/SC587/SC589/ADSP-21583/21584/21587

Table 11. ADSP-SC58x/ADSP-2158x Detailed Signal Descriptions (Continued)

Signal Name	Direction	Description
MLB_SIGP	InOut	Differential Signal (+).
MLB_CLK	Input	Single-Ended Clock.
MLB_DAT	InOut	Single-Ended Data.
MLB_SIG	InOut	Single-Ended Signal.
MLB_CLKOUT	Output	Single-Ended Clock Out.
MSI_CD	Input	Card Detect. Connects to a pull-up resistor and to the card detect output of an SD socket.
MSI_CLK	Output	Clock. The clock signal applied to the connected device from the MSI.
MSI_CMD	InOut	Command. Sends commands to and receives responses from the connected device.
MSI_D[n]	InOut	Data n. Bidirectional data bus.
MSI_INT	Input	eSDIO Interrupt Input. Used only for eSDIO. Connects to an eSDIO card interrupt output. An interrupt may be sampled even when the MSI clock to the card is switched off.
PCIE_CLKM	Input	CLK -.
PCIE_CLKP	Input	CLK +.
PCIE_REF	InOut	Reference Resistor. Attach a 200 Ω, 1%, 100 ppm/C precision resistor to ground on the board.
PCIE_RXM	Input	RX -.
PCIE_RXP	Input	RX +.
PCIE_TXM	Output	TX -.
PCIE_TXP	Output	TX +.
PPI_CLK	InOut	Clock. Input in external clock mode, output in internal clock mode.
PPI_D[nn]	InOut	Data n. Bidirectional data bus.
PPI_FS1	InOut	Frame Sync 1 (HSYNC). Behavior depends on EPPI mode. See the “EPPI” chapter of the ADSP-SC58x/ADSP-2158x SHARC+ Processor Hardware Reference for more details.
PPI_FS2	InOut	Frame Sync 2 (VSYNC). Behavior depends on EPPI mode. See the “EPPI” chapter of the ADSP-SC58x/ADSP-2158x SHARC+ Processor Hardware Reference for more details.
PPI_FS3	InOut	Frame Sync 3 (FIELD). Behavior depends on EPPI mode. See the “EPPI” chapter of the ADSP-SC58x/ADSP-2158x SHARC+ Processor Hardware Reference for more details.
PWM_AH	Output	Channel A High Side. High-side drive signal.
PWM_AL	Output	Channel A Low Side. Low-side drive signal.
PWM_BH	Output	Channel B High Side. High-side drive signal.
PWM_BL	Output	Channel B Low Side. Low-side drive signal.
PWM_CH	Output	Channel C High Side. High-side drive signal.
PWM_CL	Output	Channel C Low Side. Low-side drive signal.
PWM_DH	Output	Channel D High Side. High-side drive signal.
PWM_DL	Output	Channel D Low Side. Low-side drive signal.
PWM_SYNC	Input	PWMTMR Grouped. This input is for an externally generated sync signal. If the sync signal is internally generated, no connection is necessary.
PWM_TRIP[n]	Input	Shutdown Input n. When asserted, the selected PWM channel outputs are shut down immediately.
P_[nn]	InOut	Position n. General-purpose input/output. See the “GP Ports” chapter of the ADSP-SC58x/ADSP-2158x SHARC+ Processor Hardware Reference for more details.
RTC_CLKIN	Input	Crystal Input/External Oscillator Connection. Connect to an external clock source or crystal.
RTC_XTAL	Output	Crystal Output. Drives an external crystal. Must be left unconnected if an external clock is driving RTC_CLKIN.
SINC_CLK0	Output	Clock 0.
SINC_D0	Input	Data 0.
SINC_D1	Input	Data 1.
SINC_D2	Input	Data 2.
SINC_D3	Input	Data 3.

ADSP-SC582/SC583/SC584/SC587/SC589/ADSP-21583/21584/21587

Table 11. ADSP-SC58x/ADSP-2158x Detailed Signal Descriptions (Continued)

Signal Name	Direction	Description
$\overline{\text{SMC_ABE}}[n]$	Output	Byte Enable n. Indicates whether the lower or upper byte of a memory is being accessed. When an asynchronous write is made to the upper byte of a 16-bit memory, $\overline{\text{SMC_ABE}}1 = 0$ and $\overline{\text{SMC_ABE}}0 = 1$. When an asynchronous write is made to the lower byte of a 16-bit memory, $\overline{\text{SMC_ABE}}1 = 1$ and $\overline{\text{SMC_ABE}}0 = 0$.
$\overline{\text{SMC_AMS}}[n]$	Output	Memory Select n. Typically connects to the chip select of a memory device.
$\overline{\text{SMC_AOE}}$	Output	Output Enable. Asserts at the beginning of the setup period of a read access.
SMC_ARDY	Input	Asynchronous Ready. Flow control signal used by memory devices to indicate to the SMC when further transactions may proceed.
$\overline{\text{SMC_ARE}}$	Output	Read Enable. Asserts at the beginning of a read access.
$\overline{\text{SMC_AWE}}$	Output	Write Enable. Asserts for the duration of a write access period.
$\text{SMC_A}[nn]$	Output	Address n. Address bus.
$\text{SMC_D}[nn]$	InOut	Data n. Bidirectional data bus.
SPI_CLK	InOut	Clock. Input in slave mode, output in master mode.
SPI_D2	InOut	Data 2. Transfers serial data in quad mode. Open-drain when ODM mode is enabled.
SPI_D3	InOut	Data 3. Transfers serial data in quad mode. Open-drain when ODM mode is enabled.
SPI_MISO	InOut	Master In, Slave Out. Transfers serial data. Operates in the same direction as SPI_MOSI in dual and quad modes. Open-drain when ODM mode is enabled.
SPI_MOSI	InOut	Master Out, Slave In. Transfers serial data. Operates in the same direction as SPI_MISO in dual and quad modes. Open-drain when ODM mode is enabled.
SPI_RDY	InOut	Ready. Optional flow signal. Output in slave mode, input in master mode.
$\overline{\text{SPI_SEL}}[n]$	Output	Slave Select Output n. Used in master mode to enable the desired slave.
$\overline{\text{SPI_SS}}$	Input	Slave Select Input. Slave mode—acts as the slave select input. Master mode—optionally serves as an error detection input for the SPI when there are multiple masters.
SPT_ACLK	InOut	Channel A Clock. Data and frame sync are driven/sampled with respect to this clock. This signal can be either internally or externally generated.
SPT_AD0	InOut	Channel A Data 0. Primary bidirectional data I/O. This signal can be configured as an output to transmit serial data or as an input to receive serial data.
SPT_AD1	InOut	Channel A Data 1. Secondary bidirectional data I/O. This signal can be configured as an output to transmit serial data or as an input to receive serial data.
SPT_AFS	InOut	Channel A Frame Sync. The frame sync pulse initiates shifting of the serial data. This signal is either generated internally or externally.
SPT_ATDV	Output	Channel A Transmit Data Valid. This signal is optional and only active when SPORT is configured in multichannel transmit mode. It is asserted during enabled slots.
SPT_BCLK	InOut	Channel B Clock. Data and frame sync are driven/sampled with respect to this clock. This signal can be either internally or externally generated.
SPT_BD0	InOut	Channel B Data 0. Primary bidirectional data I/O. This signal can be configured as an output to transmit serial data or as an input to receive serial data.
SPT_BD1	InOut	Channel B Data 1. Secondary bidirectional data I/O. This signal can be configured as an output to transmit serial data or as an input to receive serial data.
SPT_BFS	InOut	Channel B Frame Sync. The frame sync pulse initiates shifting of serial data. This signal is either generated internally or externally.
SPT_BTDV	Output	Channel B Transmit Data Valid. This signal is optional and only active when SPORT is configured in multichannel transmit mode. It is asserted during enabled slots.
$\text{SYS_BMODE}[n]$	Input	Boot Mode Control n. Selects the boot mode of the processor.
SYS_CLKIN0	Input	Clock/Crystal Input.
SYS_CLKIN1	Input	Clock/Crystal Input.
SYS_CLKOUT	Output	Processor Clock Output. Outputs internal clocks. Clocks may be divided down. See the “CGU” chapter of the ADSP-SC58x/ADSP-2158x SHARC+ Processor Hardware Reference for more details.

ADSP-SC582/SC583/SC584/SC587/SC589/ADSP-21583/21584/21587

Table 11. ADSP-SC58x/ADSP-2158x Detailed Signal Descriptions (Continued)

Signal Name	Direction	Description
SYS_FAULT	InOut	Active High Fault Output. Indicates internal faults or senses external faults, depending on the operating mode.
$\overline{\text{SYS_FAULT}}$	InOut	Active Low Fault Output. Indicates internal faults or senses external faults, depending on the operating mode.
$\overline{\text{SYS_HWRST}}$	Input	Processor Hardware Reset Control. Resets the device when asserted.
SYS_RESOUT	Output	Reset Output. Indicates the device is in the reset state.
SYS_XTALO	Output	Crystal Output.
SYS_XTAL1	Output	Crystal Output.
TM_ACI[n]	Input	Alternate Capture Input n. Provides an additional input for WIDCAP, WATCHDOG, and PININT modes.
TM_ACLK[n]	Input	Alternate Clock n. Provides an additional time base for an individual timer.
TM_CLK	Input	Clock. Provides an additional global time base for all GP timers.
TM_TMR[n]	InOut	Timer n. The main input/output signal for each timer.
TRACE_CLK	Output	Trace Clock. Clock output.
TRACE_D[nn]	Output	Trace Data n. Unidirectional data bus.
TWI_SCL	InOut	Serial Clock. Clock output when master, clock input when slave.
TWI_SDA	InOut	Serial Data. Receives or transmits data.
$\overline{\text{UART_CTS}}$	Input	Clear to Send. Flow control signal.
$\overline{\text{UART_RTS}}$	Output	Request to Send. Flow control signal.
$\overline{\text{UART_RX}}$	Input	Receive. Receives input. Typically connects to a transceiver that meets the electrical requirements of the device being communicated with.
$\overline{\text{UART_TX}}$	Output	Transmit. Transmits output. Typically connects to a transceiver that meets the electrical requirements of the device being communicated with.
USB_CLKIN	Input	Clock/Crystal Input. This clock input is multiplied by a PLL to form the USB clock. See data sheet specifications for frequency/tolerance information.
USB_DM	InOut	Data -. Bidirectional differential data line.
USB_DP	InOut	Data +. Bidirectional differential data line.
USB_ID	Input	OTG ID. Senses whether the controller is a host or device. This signal is pulled low when an A-type plug is sensed (signifying that the USB controller is the A device). The input is high when a B-type plug is sensed (signifying that the USB controller is the B device).
USB_VBC	Output	VBUS Control. Controls an external voltage source to supply VBUS when in host mode. Can be configured as open drain. Polarity is configurable as well.
USB_VBUS	InOut	Bus Voltage. Connects to bus voltage in host and device modes.
USB_XTAL	Output	Crystal. Drives an external crystal. Must be left unconnected if an external clock is driving USB_CLKIN.

ADSP-SC582/SC583/SC584/SC587/SC589/ADSP-21583/21584/21587

349-BALL CSP_BGA SIGNAL DESCRIPTIONS

The processor pin definitions are shown in [Table 12](#) for the 349-ball CSP_BGA package. The columns in this table provide the following information:

- The Signal Name column includes the signal name for every pin and the GPIO multiplexed pin function, where applicable.
- The Description column provides a descriptive name for each signal.
- The Port column shows whether or not a signal is multiplexed with other signals on a general-purpose I/O port pin.
- The Pin Name column identifies the name of the package pin (at power on reset) on which the signal is located (if a single function pin) or is multiplexed (if a general-purpose I/O pin).
- The DAI pins and their associated signal routing units (SRUs) connect inputs and outputs of the DAI peripherals (SPORT, ASRC, S/PDIF, and PCG). See the “Digital Audio Interface (DAI)” chapter of the [ADSP-SC58x/ADSP-2158x SHARC+ Processor Hardware Reference](#) for complete information on the use of the DAI and SRUs.

Table 12. ADSP-SC58x/ADSP-2158x 349-Ball CSP_BGA Signal Descriptions

Signal Name	Description	Port	Pin Name
ACM0_A0	ACM0 ADC Control Signals	C	PC_13
ACM0_A1	ACM0 ADC Control Signals	C	PC_14
ACM0_A2	ACM0 ADC Control Signals	C	PC_15
ACM0_A3	ACM0 ADC Control Signals	D	PD_00
ACM0_A4	ACM0 ADC Control Signals	D	PD_01
ACM0_T0	ACM0 External Trigger n	C	PC_12
C1_FLG0	SHARC Core 1 Flag Pin	E	PE_01
C1_FLG1	SHARC Core 1 Flag Pin	E	PE_03
C1_FLG2	SHARC Core 1 Flag Pin	E	PE_05
C1_FLG3	SHARC Core 1 Flag Pin	E	PE_07
C2_FLG0	SHARC Core 2 Flag Pin	E	PE_02
C2_FLG1	SHARC Core 2 Flag Pin	E	PE_04
C2_FLG2	SHARC Core 2 Flag Pin	E	PE_06
C2_FLG3	SHARC Core 2 Flag Pin	E	PE_08
CAN0_RX	CAN0 Receive	C	PC_07
CAN0_TX	CAN0 Transmit	C	PC_08
CAN1_RX	CAN1 Receive	B	PB_10
CAN1_TX	CAN1 Transmit	B	PB_09
CNT0_DG	CNT0 Count Down and Gate	B	PB_14
CNT0_UD	CNT0 Count Up and Direction	B	PB_12
CNT0_ZM	CNT0 Count Zero Marker	B	PB_11
DAIO_PIN01	DAIO Pin 1	Not Muxed	DAIO_PIN01
DAIO_PIN02	DAIO Pin 2	Not Muxed	DAIO_PIN02
DAIO_PIN03	DAIO Pin 3	Not Muxed	DAIO_PIN03
DAIO_PIN04	DAIO Pin 4	Not Muxed	DAIO_PIN04
DAIO_PIN05	DAIO Pin 5	Not Muxed	DAIO_PIN05
DAIO_PIN06	DAIO Pin 6	Not Muxed	DAIO_PIN06
DAIO_PIN07	DAIO Pin 7	Not Muxed	DAIO_PIN07
DAIO_PIN08	DAIO Pin 8	Not Muxed	DAIO_PIN08
DAIO_PIN09	DAIO Pin 9	Not Muxed	DAIO_PIN09
DAIO_PIN10	DAIO Pin 10	Not Muxed	DAIO_PIN10
DAIO_PIN11	DAIO Pin 11	Not Muxed	DAIO_PIN11
DAIO_PIN12	DAIO Pin 12	Not Muxed	DAIO_PIN12
DAIO_PIN19	DAIO Pin 19	Not Muxed	DAIO_PIN19
DAIO_PIN20	DAIO Pin 20	Not Muxed	DAIO_PIN20

ADSP-SC582/SC583/SC584/SC587/SC589/ADSP-21583/21584/21587

Table 12. ADSP-SC58x/ADSP-2158x 349-Ball CSP_BGA Signal Descriptions (Continued)

Signal Name	Description	Port	Pin Name
DAI1_PIN01	DAI1 Pin 1	Not Muxed	DAI1_PIN01
DAI1_PIN02	DAI1 Pin 2	Not Muxed	DAI1_PIN02
DAI1_PIN03	DAI1 Pin 3	Not Muxed	DAI1_PIN03
DAI1_PIN04	DAI1 Pin 4	Not Muxed	DAI1_PIN04
DAI1_PIN05	DAI1 Pin 5	Not Muxed	DAI1_PIN05
DAI1_PIN06	DAI1 Pin 6	Not Muxed	DAI1_PIN06
DAI1_PIN07	DAI1 Pin 7	Not Muxed	DAI1_PIN07
DAI1_PIN08	DAI1 Pin 8	Not Muxed	DAI1_PIN08
DAI1_PIN09	DAI1 Pin 9	Not Muxed	DAI1_PIN09
DAI1_PIN10	DAI1 Pin 10	Not Muxed	DAI1_PIN10
DAI1_PIN11	DAI1 Pin 11	Not Muxed	DAI1_PIN11
DAI1_PIN12	DAI1 Pin 12	Not Muxed	DAI1_PIN12
DAI1_PIN19	DAI1 Pin 19	Not Muxed	DAI1_PIN19
DAI1_PIN20	DAI1 Pin 20	Not Muxed	DAI1_PIN20
DMC0_A00	DMC0 Address 0	Not Muxed	DMC0_A00
DMC0_A01	DMC0 Address 1	Not Muxed	DMC0_A01
DMC0_A02	DMC0 Address 2	Not Muxed	DMC0_A02
DMC0_A03	DMC0 Address 3	Not Muxed	DMC0_A03
DMC0_A04	DMC0 Address 4	Not Muxed	DMC0_A04
DMC0_A05	DMC0 Address 5	Not Muxed	DMC0_A05
DMC0_A06	DMC0 Address 6	Not Muxed	DMC0_A06
DMC0_A07	DMC0 Address 7	Not Muxed	DMC0_A07
DMC0_A08	DMC0 Address 8	Not Muxed	DMC0_A08
DMC0_A09	DMC0 Address 9	Not Muxed	DMC0_A09
DMC0_A10	DMC0 Address 10	Not Muxed	DMC0_A10
DMC0_A11	DMC0 Address 11	Not Muxed	DMC0_A11
DMC0_A12	DMC0 Address 12	Not Muxed	DMC0_A12
DMC0_A13	DMC0 Address 13	Not Muxed	DMC0_A13
DMC0_A14	DMC0 Address 14	Not Muxed	DMC0_A14
DMC0_A15	DMC0 Address 15	Not Muxed	DMC0_A15
DMC0_BA0	DMC0 Bank Address 0	Not Muxed	DMC0_BA0
DMC0_BA1	DMC0 Bank Address 1	Not Muxed	DMC0_BA1
DMC0_BA2	DMC0 Bank Address 2	Not Muxed	DMC0_BA2
$\overline{\text{DMC0_CAS}}$	DMC0 Column Address Strobe	Not Muxed	$\overline{\text{DMC0_CAS}}$
DMC0_CK	DMC0 Clock	Not Muxed	DMC0_CK
DMC0_CKE	DMC0 Clock Enable	Not Muxed	DMC0_CKE
$\overline{\text{DMC0_CK}}$	DMC0 Clock (Complement)	Not Muxed	$\overline{\text{DMC0_CK}}$
$\overline{\text{DMC0_CS0}}$	DMC0 Chip Select 0	Not Muxed	$\overline{\text{DMC0_CS0}}$
DMC0_DQ00	DMC0 Data 0	Not Muxed	DMC0_DQ00
DMC0_DQ01	DMC0 Data 1	Not Muxed	DMC0_DQ01
DMC0_DQ02	DMC0 Data 2	Not Muxed	DMC0_DQ02
DMC0_DQ03	DMC0 Data 3	Not Muxed	DMC0_DQ03
DMC0_DQ04	DMC0 Data 4	Not Muxed	DMC0_DQ04
DMC0_DQ05	DMC0 Data 5	Not Muxed	DMC0_DQ05
DMC0_DQ06	DMC0 Data 6	Not Muxed	DMC0_DQ06
DMC0_DQ07	DMC0 Data 7	Not Muxed	DMC0_DQ07
DMC0_DQ08	DMC0 Data 8	Not Muxed	DMC0_DQ08
DMC0_DQ09	DMC0 Data 9	Not Muxed	DMC0_DQ09

ADSP-SC582/SC583/SC584/SC587/SC589/ADSP-21583/21584/21587

Table 12. ADSP-SC58x/ADSP-2158x 349-Ball CSP_BGA Signal Descriptions (Continued)

Signal Name	Description	Port	Pin Name
DMC0_DQ10	DMC0 Data 10	Not Muxed	DMC0_DQ10
DMC0_DQ11	DMC0 Data 11	Not Muxed	DMC0_DQ11
DMC0_DQ12	DMC0 Data 12	Not Muxed	DMC0_DQ12
DMC0_DQ13	DMC0 Data 13	Not Muxed	DMC0_DQ13
DMC0_DQ14	DMC0 Data 14	Not Muxed	DMC0_DQ14
DMC0_DQ15	DMC0 Data 15	Not Muxed	DMC0_DQ15
DMC0_LDM	DMC0 Data Mask for Lower Byte	Not Muxed	DMC0_LDM
DMC0_LDQS	DMC0 Data Strobe for Lower Byte	Not Muxed	DMC0_LDQS
$\overline{\text{DMC0_LDQS}}$	DMC0 Data Strobe for Lower Byte (Complement)	Not Muxed	$\overline{\text{DMC0_LDQS}}$
DMC0_ODT	DMC0 On-Die Termination	Not Muxed	DMC0_ODT
$\overline{\text{DMC0_RAS}}$	DMC0 Row Address Strobe	Not Muxed	$\overline{\text{DMC0_RAS}}$
$\overline{\text{DMC0_RESET}}$	DMC0 Reset (DDR3 Only)	Not Muxed	$\overline{\text{DMC0_RESET}}$
DMC0_RZQ	DMC0 External Calibration Resistor Connection	Not Muxed	DMC0_RZQ
DMC0_UDM	DMC0 Data Mask for Upper Byte	Not Muxed	DMC0_UDM
DMC0_UDQS	DMC0 Data Strobe for Upper Byte	Not Muxed	DMC0_UDQS
$\overline{\text{DMC0_UDQS}}$	DMC0 Data Strobe for Upper Byte (Complement)	Not Muxed	$\overline{\text{DMC0_UDQS}}$
DMC0_VREF	DMC0 Voltage Reference	Not Muxed	DMC0_VREF
$\overline{\text{DMC0_WE}}$	DMC0 Write Enable	Not Muxed	$\overline{\text{DMC0_WE}}$
ETH0_CRS	ETH0 Carrier Sense/RMII Receive Data Valid	A	PA_07
ETH0_MDC	ETH0 Management Channel Clock	A	PA_02
ETH0_MDIO	ETH0 Management Channel Serial Data	A	PA_03
ETH0_PTPAUXIN0	ETH0 PTP Auxiliary Trigger Input 0	B	PB_03
ETH0_PTPAUXIN1	ETH0 PTP Auxiliary Trigger Input 1	B	PB_04
ETH0_PTPAUXIN2	ETH0 PTP Auxiliary Trigger Input 2	B	PB_05
ETH0_PTPAUXIN3	ETH0 PTP Auxiliary Trigger Input 3	B	PB_06
ETH0_PTPCLKIN0	ETH0 PTP Clock Input 0	B	PB_02
ETH0_PTPPPS0	ETH0 PTP Pulse Per Second Output 0	B	PB_01
ETH0_PTPPPS1	ETH0 PTP Pulse Per Second Output 1	B	PB_00
ETH0_PTPPPS2	ETH0 PTP Pulse Per Second Output 2	A	PA_15
ETH0_PTPPPS3	ETH0 PTP Pulse Per Second Output 3	A	PA_14
ETH0_RXCLK_REFCLK	ETH0 RXCLK (10/100/1000) or REFCLK (10/100)	A	PA_06
ETH0_RXCTL_CRS	ETH0 RXCTL (10/100/1000) or CRS (10/100)	A	PA_07
ETH0_RXD0	ETH0 Receive Data 0	A	PA_04
ETH0_RXD1	ETH0 Receive Data 1	A	PA_05
ETH0_RXD2	ETH0 Receive Data 2	A	PA_08
ETH0_RXD3	ETH0 Receive Data 3	A	PA_09
ETH0_TXCLK	ETH0 Transmit Clock	A	PA_11
ETH0_TXCTL_TXEN	ETH0 TXCTL (10/100/1000) or TXEN (10/100)	A	PA_10
ETH0_TXD0	ETH0 Transmit Data 0	A	PA_00
ETH0_TXD1	ETH0 Transmit Data 1	A	PA_01
ETH0_TXD2	ETH0 Transmit Data 2	A	PA_12
ETH0_TXD3	ETH0 Transmit Data 3	A	PA_13
ETH0_TXEN	ETH0 Transmit Enable	A	PA_10
HADC0_VIN0	HADC0 Analog Input at Channel 0	Not Muxed	HADC0_VIN0
HADC0_VIN1	HADC0 Analog Input at Channel 1	Not Muxed	HADC0_VIN1
HADC0_VIN2	HADC0 Analog Input at Channel 2	Not Muxed	HADC0_VIN2
HADC0_VIN3	HADC0 Analog Input at Channel 3	Not Muxed	HADC0_VIN3
HADC0_VIN4	HADC0 Analog Input at Channel 4	Not Muxed	HADC0_VIN4

ADSP-SC582/SC583/SC584/SC587/SC589/ADSP-21583/21584/21587

Table 12. ADSP-SC58x/ADSP-2158x 349-Ball CSP_BGA Signal Descriptions (Continued)

Signal Name	Description	Port	Pin Name
HADC0_VIN5	HADC0 Analog Input at Channel 5	Not Muxed	HADC0_VIN5
HADC0_VIN6	HADC0 Analog Input at Channel 6	Not Muxed	HADC0_VIN6
HADC0_VIN7	HADC0 Analog Input at Channel 7	Not Muxed	HADC0_VIN7
HADC0_VREFN	HADC0 Ground Reference for ADC	Not Muxed	HADC0_VREFN
HADC0_VREFP	HADC0 External Reference for ADC	Not Muxed	HADC0_VREFP
JTG_TCK	TAPC JTAG Clock	Not Muxed	JTG_TCK
JTG_TDI	TAPC JTAG Serial Data In	Not Muxed	JTG_TDI
JTG_TDO	TAPC JTAG Serial Data Out	Not Muxed	JTG_TDO
JTG_TMS	TAPC JTAG Mode Select	Not Muxed	JTG_TMS
JTG_TRST	TAPC JTAG Reset	Not Muxed	JTG_TRST
LP0_ACK	LP0 Acknowledge	D	PD_11
LP0_CLK	LP0 Clock	D	PD_10
LP0_D0	LP0 Data 0	D	PD_02
LP0_D1	LP0 Data 1	D	PD_03
LP0_D2	LP0 Data 2	D	PD_04
LP0_D3	LP0 Data 3	D	PD_05
LP0_D4	LP0 Data 4	D	PD_06
LP0_D5	LP0 Data 5	D	PD_07
LP0_D6	LP0 Data 6	D	PD_08
LP0_D7	LP0 Data 7	D	PD_09
LP1_ACK	LP1 Acknowledge	B	PB_15
LP1_CLK	LP1 Clock	C	PC_00
LP1_D0	LP1 Data 0	B	PB_07
LP1_D1	LP1 Data 1	B	PB_08
LP1_D2	LP1 Data 2	B	PB_09
LP1_D3	LP1 Data 3	B	PB_10
LP1_D4	LP1 Data 4	B	PB_11
LP1_D5	LP1 Data 5	B	PB_12
LP1_D6	LP1 Data 6	B	PB_13
LP1_D7	LP1 Data 7	B	PB_14
MLB0_CLKN	MLB0 Negative Differential Clock (-)	Not Muxed	MLB0_CLKN
MLB0_CLKP	MLB0 Positive Differential Clock (+)	Not Muxed	MLB0_CLKP
MLB0_DATN	MLB0 Negative Differential Data (-)	Not Muxed	MLB0_DATN
MLB0_DATP	MLB0 Positive Differential Data (+)	Not Muxed	MLB0_DATP
MLB0_SIGN	MLB0 Negative Differential Signal (-)	Not Muxed	MLB0_SIGN
MLB0_SIGP	MLB0 Positive Differential Signal (+)	Not Muxed	MLB0_SIGP
MLB0_CLK	MLB0 Single-Ended Clock	B	PB_04
MLB0_DAT	MLB0 Single-Ended Data	B	PB_06
MLB0_SIG	MLB0 Single-Ended Signal	B	PB_05
MLB0_CLKOUT	MLB0 Single-Ended Clock Out	D	PD_14
PA_00-15	PORTA Position 00 Through Position 15	A	PA_00-15
PB_00-15	PORTB Position 00 Through Position 15	B	PB_00-15
PC_00-15	PORTC Position 00 Through Position 15	C	PC_00-15
PD_00-15	PORTD Position 00 Through Position 15	D	PD_00-15
PE_00-15	PORTE Position 00 Through Position 15	E	PE_00-15
PPIO_CLK	EPPIO Clock	E	PE_03
PPIO_D00	EPPIO Data 0	E	PE_12
PPIO_D01	EPPIO Data 1	E	PE_11

ADSP-SC582/SC583/SC584/SC587/SC589/ADSP-21583/21584/21587

Table 12. ADSP-SC58x/ADSP-2158x 349-Ball CSP_BGA Signal Descriptions (Continued)

Signal Name	Description	Port	Pin Name
PPIO_D02	EPPIO Data 2	E	PE_10
PPIO_D03	EPPIO Data 3	E	PE_09
PPIO_D04	EPPIO Data 4	E	PE_08
PPIO_D05	EPPIO Data 5	E	PE_07
PPIO_D06	EPPIO Data 6	E	PE_06
PPIO_D07	EPPIO Data 7	E	PE_05
PPIO_D08	EPPIO Data 8	E	PE_04
PPIO_D09	EPPIO Data 9	E	PE_00
PPIO_D10	EPPIO Data 10	D	PD_15
PPIO_D11	EPPIO Data 11	D	PD_14
PPIO_D12	EPPIO Data 12	B	PB_04
PPIO_D13	EPPIO Data 13	B	PB_05
PPIO_D14	EPPIO Data 14	B	PB_00
PPIO_D15	EPPIO Data 15	B	PB_01
PPIO_D16	EPPIO Data 16	B	PB_02
PPIO_D17	EPPIO Data 17	B	PB_03
PPIO_D18	EPPIO Data 18	D	PD_13
PPIO_D19	EPPIO Data 19	D	PD_12
PPIO_D20	EPPIO Data 20	E	PE_13
PPIO_D21	EPPIO Data 21	E	PE_14
PPIO_D22	EPPIO Data 22	E	PE_15
PPIO_D23	EPPIO Data 23	D	PD_00
PPIO_FS1	EPPIO Frame Sync 1 (HSYNC)	E	PE_02
PPIO_FS2	EPPIO Frame Sync 2 (VSYNC)	E	PE_01
PPIO_FS3	EPPIO Frame Sync 3 (FIELD)	C	PC_15
PWM0_AH	PWM0 Channel A High Side	B	PB_07
PWM0_AL	PWM0 Channel A Low Side	B	PB_08
PWM0_BH	PWM0 Channel B High Side	B	PB_06
PWM0_BL	PWM0 Channel B Low Side	C	PC_00
PWM0_CH	PWM0 Channel C High Side	B	PB_13
PWM0_CL	PWM0 Channel C Low Side	B	PB_14
PWM0_DH	PWM0 Channel D High Side	B	PB_11
PWM0_DL	PWM0 Channel D Low Side	B	PB_12
PWM0_SYNC	PWM0 PWMTMR Grouped	E	PE_09
PWM0_TRIP0	PWM0 Shutdown Input 0	B	PB_15
PWM1_AH	PWM1 Channel A High Side	D	PD_03
PWM1_AL	PWM1 Channel A Low Side	D	PD_04
PWM1_BH	PWM1 Channel B High Side	D	PD_05
PWM1_BL	PWM1 Channel B Low Side	D	PD_06
PWM1_CH	PWM1 Channel C High Side	D	PD_07
PWM1_CL	PWM1 Channel C Low Side	D	PD_08
PWM1_DH	PWM1 Channel D High Side	D	PD_09
PWM1_DL	PWM1 Channel D Low Side	D	PD_10
PWM1_SYNC	PWM1 PWMTMR Grouped	D	PD_11
PWM1_TRIP0	PWM1 Shutdown Input 0	D	PD_02
PWM2_CH	PWM2 Channel C High Side	D	PD_15
PWM2_CL	PWM2 Channel C Low Side	E	PE_00
PWM2_DH	PWM2 Channel D High Side	E	PE_04

ADSP-SC582/SC583/SC584/SC587/SC589/ADSP-21583/21584/21587

Table 12. ADSP-SC58x/ADSP-2158x 349-Ball CSP_BGA Signal Descriptions (Continued)

Signal Name	Description	Port	Pin Name
PWM2_DL	PWM2 Channel D Low Side	E	PE_10
PWM2_SYNC	PWM2 PWMTMR Grouped	E	PE_05
PWM2_TRIP0	PWM2 Shutdown Input 0	D	PD_14
GND	Ground	Not Muxed	GND
VDD_EXT	External Voltage Domain	Not Muxed	VDD_EXT
VDD_INT	Internal Voltage Domain	Not Muxed	VDD_INT
SINC0_CLK0	SINC0 Clock 0	B	PB_01
SINC0_D0	SINC0 Data 0	A	PA_14
SINC0_D1	SINC0 Data 1	A	PA_15
SINC0_D2	SINC0 Data 2	B	PB_00
SINC0_D3	SINC0 Data 3	B	PB_04
SMC0_A01	SMC0 Address 1	B	PB_05
SMC0_A02	SMC0 Address 2	B	PB_06
SMC0_A03	SMC0 Address 3	B	PB_03
SMC0_A04	SMC0 Address 4	B	PB_02
SMC0_A05	SMC0 Address 5	D	PD_13
SMC0_A06	SMC0 Address 6	D	PD_12
SMC0_A07	SMC0 Address 7	B	PB_01
SMC0_A08	SMC0 Address 8	B	PB_00
SMC0_A09	SMC0 Address 9	A	PA_15
SMC0_A10	SMC0 Address 10	A	PA_14
SMC0_A11	SMC0 Address 11	A	PA_09
SMC0_A12	SMC0 Address 12	A	PA_08
SMC0_A13	SMC0 Address 13	A	PA_13
SMC0_A14	SMC0 Address 14	A	PA_12
SMC0_A15	SMC0 Address 15	A	PA_11
SMC0_A16	SMC0 Address 16	A	PA_07
SMC0_A17	SMC0 Address 17	A	PA_06
SMC0_A18	SMC0 Address 18	A	PA_05
SMC0_A19	SMC0 Address 19	A	PA_04
SMC0_A20	SMC0 Address 20	A	PA_01
SMC0_A21	SMC0 Address 21	A	PA_00
SMC0_A22	SMC0 Address 22	A	PA_10
SMC0_A23	SMC0 Address 23	A	PA_03
SMC0_A24	SMC0 Address 24	A	PA_02
SMC0_A25	SMC0 Address 25	C	PC_12
SMC0_ABE0	SMC0 Byte Enable 0	E	PE_14
SMC0_ABE1	SMC0 Byte Enable 1	E	PE_15
SMC0_AMS0	SMC0 Memory Select 0	C	PC_15
SMC0_AMS1	SMC0 Memory Select 1	E	PE_13
SMC0_AMS2	SMC0 Memory Select 2	C	PC_07
SMC0_AMS3	SMC0 Memory Select 3	C	PC_08
SMC0_AOE	SMC0 Output Enable	D	PD_01
SMC0_ARDY	SMC0 Asynchronous Ready	B	PB_04
SMC0_ARE	SMC0 Read Enable	C	PC_00
SMC0_AWE	SMC0 Write Enable	B	PB_15
SMC0_D00	SMC0 Data 0	E	PE_12
SMC0_D01	SMC0 Data 1	E	PE_11

ADSP-SC582/SC583/SC584/SC587/SC589/ADSP-21583/21584/21587

Table 12. ADSP-SC58x/ADSP-2158x 349-Ball CSP_BGA Signal Descriptions (Continued)

Signal Name	Description	Port	Pin Name
SMC0_D02	SMC0 Data 2	E	PE_10
SMC0_D03	SMC0 Data 3	E	PE_09
SMC0_D04	SMC0 Data 4	E	PE_00
SMC0_D05	SMC0 Data 5	D	PD_15
SMC0_D06	SMC0 Data 6	D	PD_14
SMC0_D07	SMC0 Data 7	D	PD_00
SMC0_D08	SMC0 Data 8	B	PB_14
SMC0_D09	SMC0 Data 9	B	PB_13
SMC0_D10	SMC0 Data 10	B	PB_12
SMC0_D11	SMC0 Data 11	B	PB_11
SMC0_D12	SMC0 Data 12	B	PB_10
SMC0_D13	SMC0 Data 13	B	PB_09
SMC0_D14	SMC0 Data 14	B	PB_08
SMC0_D15	SMC0 Data 15	B	PB_07
SPI0_CLK	SPI0 Clock	C	PC_09
SPI0_MISO	SPI0 Master In, Slave Out	C	PC_10
SPI0_MOSI	SPI0 Master Out, Slave In	C	PC_11
SPI0_RDY	SPI0 Ready	C	PC_12
$\overline{\text{SPI0_SEL1}}$	SPI0 Slave Select Output 1	C	PC_07
$\overline{\text{SPI0_SEL2}}$	SPI0 Slave Select Output 2	D	PD_01
$\overline{\text{SPI0_SEL3}}$	SPI0 Slave Select Output 3	C	PC_12
$\overline{\text{SPI0_SEL4}}$	SPI0 Slave Select Output 4	C	PC_00
$\overline{\text{SPI0_SEL5}}$	SPI0 Slave Select Output 5	E	PE_01
$\overline{\text{SPI0_SEL6}}$	SPI0 Slave Select Output 6	E	PE_02
$\overline{\text{SPI0_SEL7}}$	SPI0 Slave Select Output 7	E	PE_03
$\overline{\text{SPI0_SS}}$	SPI0 Slave Select Input	D	PD_01
SPI1_CLK	SPI1 Clock	E	PE_13
SPI1_MISO	SPI1 Master In, Slave Out	E	PE_14
SPI1_MOSI	SPI1 Master Out, Slave In	E	PE_15
SPI1_RDY	SPI1 Ready	E	PE_08
$\overline{\text{SPI1_SEL1}}$	SPI1 Slave Select Output 1	C	PC_13
$\overline{\text{SPI1_SEL2}}$	SPI1 Slave Select Output 2	E	PE_07
$\overline{\text{SPI1_SEL3}}$	SPI1 Slave Select Output 3	E	PE_11
$\overline{\text{SPI1_SEL4}}$	SPI1 Slave Select Output 4	E	PE_12
$\overline{\text{SPI1_SEL5}}$	SPI1 Slave Select Output 5	E	PE_08
$\overline{\text{SPI1_SS}}$	SPI1 Slave Select Input	E	PE_11
SPI2_CLK	SPI2 Clock	C	PC_01
SPI2_D2	SPI2 Data 2	C	PC_04
SPI2_D3	SPI2 Data 3	C	PC_05
SPI2_MISO	SPI2 Master In, Slave Out	C	PC_02
SPI2_MOSI	SPI2 Master Out, Slave In	C	PC_03
SPI2_RDY	SPI2 Ready	E	PE_12
$\overline{\text{SPI2_SEL1}}$	SPI2 Slave Select Output 1	C	PC_06
$\overline{\text{SPI2_SEL2}}$	SPI2 Slave Select Output 2	E	PE_03
$\overline{\text{SPI2_SEL3}}$	SPI2 Slave Select Output 3	E	PE_04
$\overline{\text{SPI2_SEL4}}$	SPI2 Slave Select Output 4	E	PE_05
$\overline{\text{SPI2_SEL5}}$	SPI2 Slave Select Output 5	E	PE_06
$\overline{\text{SPI2_SS}}$	SPI2 Slave Select Input	C	PC_06

ADSP-SC582/SC583/SC584/SC587/SC589/ADSP-21583/21584/21587

Table 12. ADSP-SC58x/ADSP-2158x 349-Ball CSP_BGA Signal Descriptions (Continued)

Signal Name	Description	Port	Pin Name
SYS_BMODE0	Boot Mode Control n	Not Muxed	SYS_BMODE0
SYS_BMODE1	Boot Mode Control n	Not Muxed	SYS_BMODE1
SYS_BMODE2	Boot Mode Control n	Not Muxed	SYS_BMODE2
SYS_CLKIN0	Clock/Crystal Input	Not Muxed	SYS_CLKIN0
SYS_CLKIN1	Clock/Crystal Input	Not Muxed	SYS_CLKIN1
SYS_CLKOUT	Processor Clock Output	Not Muxed	SYS_CLKOUT
SYS_FAULT	Active High Fault Output	Not Muxed	SYS_FAULT
$\overline{\text{SYS_FAULT}}$	Active Low Fault Output	Not Muxed	$\overline{\text{SYS_FAULT}}$
$\overline{\text{SYS_HWRST}}$	Processor Hardware Reset Control	Not Muxed	$\overline{\text{SYS_HWRST}}$
$\overline{\text{SYS_RESOUT}}$	Reset Output	Not Muxed	$\overline{\text{SYS_RESOUT}}$
SYS_XTAL0	Crystal Output	Not Muxed	SYS_XTAL0
SYS_XTAL1	Crystal Output	Not Muxed	SYS_XTAL1
TM0_ACIO	TIMERO Alternate Capture Input 0	C	PC_14
TM0_AC11	TIMERO Alternate Capture Input 1	B	PB_03
TM0_AC12	TIMERO Alternate Capture Input 2	D	PD_13
TM0_AC13	TIMERO Alternate Capture Input 3	C	PC_07
TM0_AC14	TIMERO Alternate Capture Input 4	B	PB_10
TM0_ACLK1	TIMERO Alternate Clock 1	D	PD_08
TM0_ACLK2	TIMERO Alternate Clock 2	D	PD_09
TM0_ACLK3	TIMERO Alternate Clock 3	B	PB_00
TM0_ACLK4	TIMERO Alternate Clock 4	B	PB_01
TM0_CLK	TIMERO Clock	C	PC_11
TM0_TMR0	TIMERO Timer 0	E	PE_09
TM0_TMR1	TIMERO Timer 1	B	PB_15
TM0_TMR2	TIMERO Timer 2	B	PB_10
TM0_TMR3	TIMERO Timer 3	B	PB_07
TM0_TMR4	TIMERO Timer 4	B	PB_08
TM0_TMR5	TIMERO Timer 5	B	PB_14
TRACE0_CLK	TRACE0 Trace Clock	D	PD_10
TRACE0_D00	TRACE0 Trace Data 0	D	PD_02
TRACE0_D01	TRACE0 Trace Data 1	D	PD_03
TRACE0_D02	TRACE0 Trace Data 2	D	PD_04
TRACE0_D03	TRACE0 Trace Data 3	D	PD_05
TRACE0_D04	TRACE0 Trace Data 4	D	PD_06
TRACE0_D05	TRACE0 Trace Data 5	D	PD_07
TRACE0_D06	TRACE0 Trace Data 6	D	PD_08
TRACE0_D07	TRACE0 Trace Data 7	D	PD_09
TWI0_SCL	TWI0 Serial Clock	Not Muxed	TWI0_SCL
TWI0_SDA	TWI0 Serial Data	Not Muxed	TWI0_SDA
TWI1_SCL	TWI1 Serial Clock	Not Muxed	TWI1_SCL
TWI1_SDA	TWI1 Serial Data	Not Muxed	TWI1_SDA
TWI2_SCL	TWI2 Serial Clock	Not Muxed	TWI2_SCL
TWI2_SDA	TWI2 Serial Data	Not Muxed	TWI2_SDA
$\overline{\text{UART0_CTS}}$	UART0 Clear to Send	D	PD_00
$\overline{\text{UART0_RTS}}$	UART0 Request to Send	C	PC_15
$\overline{\text{UART0_RX}}$	UART0 Receive	C	PC_14
$\overline{\text{UART0_TX}}$	UART0 Transmit	C	PC_13
$\overline{\text{UART1_CTS}}$	UART1 Clear to Send	E	PE_01

ADSP-SC582/SC583/SC584/SC587/SC589/ADSP-21583/21584/21587

Table 12. ADSP-SC58x/ADSP-2158x 349-Ball CSP_BGA Signal Descriptions (Continued)

Signal Name	Description	Port	Pin Name
UART1_RT \bar{S}	UART1 Request to Send	E	PE_02
UART1_RX	UART1 Receive	B	PB_03
UART1_TX	UART1 Transmit	B	PB_02
UART2_CTS	UART2 Clear to Send	E	PE_11
UART2_RT \bar{S}	UART2 Request to Send	E	PE_10
UART2_RX	UART2 Receive	D	PD_13
UART2_TX	UART2 Transmit	D	PD_12
USB0_CLKIN	USB0 Clock/Crystal Input	Not Muxed	USB_CLKIN
USB0_DM	USB0 Negative Data (-)	Not Muxed	USB0_DM
USB0_DP	USB0 Positive Data (+)	Not Muxed	USB0_DP
USB0_ID	USB0 OTG ID	Not Muxed	USB0_ID
USB0_VBC	USB0 VBUS Control	Not Muxed	USB0_VBC
USB0_VBUS	USB0 Bus Voltage	Not Muxed	USB0_VBUS
USB0_XTAL	USB0 Crystal	Not Muxed	USB_XTAL
VDD_DMC	DMC VDD	Not Muxed	VDD_DMC
VDD_HADC	HADC/TMU VDD	Not Muxed	VDD_HADC
VDD_USB	USB VDD	Not Muxed	VDD_USB

ADSP-SC582/SC583/SC584/SC587/SC589/ADSP-21583/21584/21587

GPIO MULTIPLEXING FOR THE 349-BALL CSP_BGA PACKAGE

Table 13 through Table 17 identify the pin functions that are multiplexed on the general-purpose I/O pins of the 349-ball CSP_BGA package.

Table 13. Signal Multiplexing for Port A

Signal Name	Multiplexed Function 0	Multiplexed Function 1	Multiplexed Function 2	Multiplexed Function 3	Multiplexed Function Input Tap
PA_00	ETH0_TXD0			SMC0_A21	
PA_01	ETH0_TXD1			SMC0_A20	
PA_02	ETH0_MDC			SMC0_A24	
PA_03	ETH0_MDIO			SMC0_A23	
PA_04	ETH0_RXD0			SMC0_A19	
PA_05	ETH0_RXD1			SMC0_A18	
PA_06	ETH0_RXCLK_REFCLK			SMC0_A17	
PA_07	ETH0_CRS			SMC0_A16	
PA_08	ETH0_RXD2			SMC0_A12	
PA_09	ETH0_RXD3			SMC0_A11	
PA_10	ETH0_TXEN			SMC0_A22	
PA_11	ETH0_TXCLK			SMC0_A15	
PA_12	ETH0_TXD2			SMC0_A14	
PA_13	ETH0_TXD3			SMC0_A13	
PA_14	ETH0_PTPPPS3	SINC0_D0		SMC0_A10	
PA_15	ETH0_PTPPPS2	SINC0_D1		SMC0_A09	

Table 14. Signal Multiplexing for Port B

Signal Name	Multiplexed Function 0	Multiplexed Function 1	Multiplexed Function 2	Multiplexed Function 3	Multiplexed Function Input Tap
PB_00	ETH0_PTPPPS1	SINC0_D2	PPIO_D14	SMC0_A08	TM0_ACLK3
PB_01	ETH0_PTPPPS0	SINC0_CLK0	PPIO_D15	SMC0_A07	TM0_ACLK4
PB_02	ETH0_PTCLKIN0	UART1_TX	PPIO_D16	SMC0_A04	
PB_03	ETH0_PTPAUXIN0	UART1_RX	PPIO_D17	SMC0_A03	TM0_ACI1
PB_04	MLB0_CLK	SINC0_D3	PPIO_D12	SMC0_ARDY	ETH0_PTPAUXIN1
PB_05	MLB0_SIG		PPIO_D13	SMC0_A01	ETH0_PTPAUXIN2
PB_06	MLB0_DAT		PWM0_BH	SMC0_A02	ETH0_PTPAUXIN3
PB_07	LP1_D0	PWM0_AH	TM0_TMR3	SMC0_D15	
PB_08	LP1_D1	PWM0_AL	TM0_TMR4	SMC0_D14	
PB_09	LP1_D2		CAN1_TX	SMC0_D13	
PB_10	LP1_D3	TM0_TMR2	CAN1_RX	SMC0_D12	TM0_ACI4
PB_11	LP1_D4		PWM0_DH	SMC0_D11	CNT0_ZM
PB_12	LP1_D5		PWM0_DL	SMC0_D10	CNT0_UD
PB_13	LP1_D6		PWM0_CH	SMC0_D09	
PB_14	LP1_D7	TM0_TMR5	PWM0_CL	SMC0_D08	CNT0_DG
PB_15	LP1_ACK	PWM0_TRIP0	TM0_TMR1	SMC0_AWE	

ADSP-SC582/SC583/SC584/SC587/SC589/ADSP-21583/21584/21587

Table 15. Signal Multiplexing for Port C

Signal Name	Multiplexed Function 0	Multiplexed Function 1	Multiplexed Function 2	Multiplexed Function 3	Multiplexed Function Input Tap
PC_00	LP1_CLK	PWM0_BL	SPIO_SEL4	SMC0_ARE	
PC_01	SPI2_CLK				
PC_02	SPI2_MISO				
PC_03	SPI2_MOSI				
PC_04	SPI2_D2				
PC_05	SPI2_D3				
PC_06	SPI2_SEL1				SPI2_SS
PC_07	CAN0_RX	SPIO_SEL1		SMC0_AMS2	TM0_AC13
PC_08	CAN0_TX			SMC0_AMS3	
PC_09	SPIO_CLK				
PC_10	SPIO_MISO				
PC_11	SPIO_MOSI				TM0_CLK
PC_12	SPIO_SEL3	SPIO_RDY	ACM0_T0	SMC0_A25	
PC_13	UART0_TX	SPI1_SEL1	ACM0_A0		
PC_14	UART0_RX		ACM0_A1		TM0_AC10
PC_15	UART0_RTS	PPIO_FS3	ACM0_A2	SMC0_AMS0	

Table 16. Signal Multiplexing for Port D

Signal Name	Multiplexed Function 0	Multiplexed Function 1	Multiplexed Function 2	Multiplexed Function 3	Multiplexed Function Input Tap
PD_00	UART0_CTS	PPIO_D23	ACM0_A3	SMC0_D07	
PD_01	SPIO_SEL2		ACM0_A4	SMC0_AOE	SPI0_SS
PD_02	LP0_D0	PWM1_TRIP0	TRACE0_D00		
PD_03	LP0_D1	PWM1_AH	TRACE0_D01		
PD_04	LP0_D2	PWM1_AL	TRACE0_D02		
PD_05	LP0_D3	PWM1_BH	TRACE0_D03		
PD_06	LP0_D4	PWM1_BL	TRACE0_D04		
PD_07	LP0_D5	PWM1_CH	TRACE0_D05		
PD_08	LP0_D6	PWM1_CL	TRACE0_D06		TM0_ACLK1
PD_09	LP0_D7	PWM1_DH	TRACE0_D07		TM0_ACLK2
PD_10	LP0_CLK	PWM1_DL	TRACE0_CLK		
PD_11	LP0_ACK	PWM1_SYNC			
PD_12	UART2_TX		PPIO_D19	SMC0_A06	
PD_13	UART2_RX		PPIO_D18	SMC0_A05	TM0_AC12
PD_14	PPIO_D11	PWM2_TRIP0	MLB0_CLKOUT	SMC0_D06	
PD_15	PPIO_D10	PWM2_CH		SMC0_D05	

ADSP-SC582/SC583/SC584/SC587/SC589/ADSP-21583/21584/21587

Table 17. Signal Multiplexing for Port E

Signal Name	Multiplexed Function 0	Multiplexed Function 1	Multiplexed Function 2	Multiplexed Function 3	Multiplexed Function Input Tap
PE_00	PPIO_D09	PWM2_CL		SMC0_D04	
PE_01	PPIO_FS2	$\overline{\text{SPI0_SEL5}}$	$\overline{\text{UART1_CTS}}$	C1_FLG0	
PE_02	PPIO_FS1	$\overline{\text{SPI0_SEL6}}$	$\overline{\text{UART1_RTS}}$	C2_FLG0	
PE_03	PPIO_CLK	$\overline{\text{SPI0_SEL7}}$	$\overline{\text{SPI2_SEL2}}$	C1_FLG1	
PE_04	PPIO_D08	PWM2_DH	$\overline{\text{SPI2_SEL3}}$	C2_FLG1	
PE_05	PPIO_D07	PWM2_SYNC	$\overline{\text{SPI2_SEL4}}$	C1_FLG2	
PE_06	PPIO_D06		$\overline{\text{SPI2_SEL5}}$	C2_FLG2	
PE_07	PPIO_D05		$\overline{\text{SPI1_SEL2}}$	C1_FLG3	
PE_08	PPIO_D04	$\overline{\text{SPI1_SEL5}}$	SPI1_RDY	C2_FLG3	
PE_09	PPIO_D03	PWM0_SYNC	TM0_TMR0	SMC0_D03	
PE_10	PPIO_D02	PWM2_DL	$\overline{\text{UART2_RTS}}$	SMC0_D02	
PE_11	PPIO_D01	$\overline{\text{SPI1_SEL3}}$	$\overline{\text{UART2_CTS}}$	SMC0_D01	$\overline{\text{SPI1_SS}}$
PE_12	PPIO_D00	$\overline{\text{SPI1_SEL4}}$	SPI2_RDY	SMC0_D00	
PE_13	SPI1_CLK		PPIO_D20	$\overline{\text{SMC0_AMST}}$	
PE_14	SPI1_MISO		PPIO_D21	$\overline{\text{SMC0_ABE0}}$	
PE_15	SPI1_MOSI		PPIO_D22	$\overline{\text{SMC0_ABE1}}$	

Table 18 shows the internal timer signal routing. This table applies to both the 349-ball and 529-ball CSP_BGA packages.

Table 18. Internal Timer Signal Routing

Timer Input Signal	Internal Source
TM0_ACLK0	SYS_CLKIN1
TM0_AC15	DAI0_CRS_PB04_O
TM0_ACLK5	DAI0_CRS_PB03_O
TM0_AC16	DAI1_CRS_PB04_O
TM0_ACLK6	DAI1_CRS_PB03_O
TM0_AC17	CNT0_TO
TM0_ACLK7	SYS_CLKIN0

ADSP-SC582/SC583/SC584/SC587/SC589/ADSP-21583/21584/21587

529-BALL CSP_BGA SIGNAL DESCRIPTIONS

The processor pin definitions are shown [Table 19](#) for the 529-ball CSP_BGA package. The columns in this table provide the following information:

- The Signal Name column includes the signal name for every pin and the GPIO multiplexed pin function, where applicable.
- The Description column provides a descriptive name for each signal.
- The Port column shows whether or not a signal is multiplexed with other signals on a general-purpose I/O port pin.
- The Pin Name column identifies the name of the package pin (at power on reset) on which the signal is located (if a single function pin) or is multiplexed (if a general-purpose I/O pin).
- The DAI pins and their associated signal routing units (SRUs) connect inputs and outputs of the DAI peripherals (SPORT, ASRC, S/PDIF, and PCG). See the “Digital Audio Interface (DAI)” chapter of the [ADSP-SC58x/ADSP-2158x SHARC+ Processor Hardware Reference](#) for complete information on the use of the DAIs and SRUs.

Table 19. ADSP-SC58x/ADSP-2158x 529-Ball CSP_BGA Signal Descriptions

Signal Name	Description	Port	Pin Name
ACM0_A0	ACM0 ADC Control Signals	C	PC_13
ACM0_A1	ACM0 ADC Control Signals	C	PC_14
ACM0_A2	ACM0 ADC Control Signals	C	PC_15
ACM0_A3	ACM0 ADC Control Signals	D	PD_00
ACM0_A4	ACM0 ADC Control Signals	D	PD_01
ACM0_T0	ACM0 External Trigger n	C	PC_12
C1_FLG0	SHARC Core 1 Flag Pin	E	PE_01
C1_FLG1	SHARC Core 1 Flag Pin	E	PE_03
C1_FLG2	SHARC Core 1 Flag Pin	E	PE_05
C1_FLG3	SHARC Core 1 Flag Pin	E	PE_07
C2_FLG0	SHARC Core 2 Flag Pin	E	PE_02
C2_FLG1	SHARC Core 2 Flag Pin	E	PE_04
C2_FLG2	SHARC Core 2 Flag Pin	E	PE_06
C2_FLG3	SHARC Core 2 Flag Pin	E	PE_08
CAN0_RX	CAN0 Receive	C	PC_07
CAN0_TX	CAN0 Transmit	C	PC_08
CAN1_RX	CAN1 Receive	B	PB_10
CAN1_TX	CAN1 Transmit	B	PB_09
CNT0_DG	CNT0 Count Down and Gate	B	PB_14
CNT0_UD	CNT0 Count Up and Direction	B	PB_12
CNT0_ZM	CNT0 Count Zero Marker	B	PB_11
DAIO_PIN01	DAIO Pin 1	Not Muxed	DAIO_PIN01
DAIO_PIN02	DAIO Pin 2	Not Muxed	DAIO_PIN02
DAIO_PIN03	DAIO Pin 3	Not Muxed	DAIO_PIN03
DAIO_PIN04	DAIO Pin 4	Not Muxed	DAIO_PIN04
DAIO_PIN05	DAIO Pin 5	Not Muxed	DAIO_PIN05
DAIO_PIN06	DAIO Pin 6	Not Muxed	DAIO_PIN06
DAIO_PIN07	DAIO Pin 7	Not Muxed	DAIO_PIN07
DAIO_PIN08	DAIO Pin 8	Not Muxed	DAIO_PIN08
DAIO_PIN09	DAIO Pin 9	Not Muxed	DAIO_PIN09
DAIO_PIN10	DAIO Pin 10	Not Muxed	DAIO_PIN10
DAIO_PIN11	DAIO Pin 11	Not Muxed	DAIO_PIN11
DAIO_PIN12	DAIO Pin 12	Not Muxed	DAIO_PIN12
DAIO_PIN13	DAIO Pin 13	Not Muxed	DAIO_PIN13
DAIO_PIN14	DAIO Pin 14	Not Muxed	DAIO_PIN14

ADSP-SC582/SC583/SC584/SC587/SC589/ADSP-21583/21584/21587

Table 19. ADSP-SC58x/ADSP-2158x 529-Ball CSP_BGA Signal Descriptions (Continued)

Signal Name	Description	Port	Pin Name
DAI0_PIN15	DAI0 Pin 15	Not Muxed	DAI0_PIN15
DAI0_PIN16	DAI0 Pin 16	Not Muxed	DAI0_PIN16
DAI0_PIN17	DAI0 Pin 17	Not Muxed	DAI0_PIN17
DAI0_PIN18	DAI0 Pin 18	Not Muxed	DAI0_PIN18
DAI0_PIN19	DAI0 Pin 19	Not Muxed	DAI0_PIN19
DAI0_PIN20	DAI0 Pin 20	Not Muxed	DAI0_PIN20
DAI1_PIN01	DAI1 Pin 1	Not Muxed	DAI1_PIN01
DAI1_PIN02	DAI1 Pin 2	Not Muxed	DAI1_PIN02
DAI1_PIN03	DAI1 Pin 3	Not Muxed	DAI1_PIN03
DAI1_PIN04	DAI1 Pin 4	Not Muxed	DAI1_PIN04
DAI1_PIN05	DAI1 Pin 5	Not Muxed	DAI1_PIN05
DAI1_PIN06	DAI1 Pin 6	Not Muxed	DAI1_PIN06
DAI1_PIN07	DAI1 Pin 7	Not Muxed	DAI1_PIN07
DAI1_PIN08	DAI1 Pin 8	Not Muxed	DAI1_PIN08
DAI1_PIN09	DAI1 Pin 9	Not Muxed	DAI1_PIN09
DAI1_PIN10	DAI1 Pin 10	Not Muxed	DAI1_PIN10
DAI1_PIN11	DAI1 Pin 11	Not Muxed	DAI1_PIN11
DAI1_PIN12	DAI1 Pin 12	Not Muxed	DAI1_PIN12
DAI1_PIN13	DAI1 Pin 13	Not Muxed	DAI1_PIN13
DAI1_PIN14	DAI1 Pin 14	Not Muxed	DAI1_PIN14
DAI1_PIN15	DAI1 Pin 15	Not Muxed	DAI1_PIN15
DAI1_PIN16	DAI1 Pin 16	Not Muxed	DAI1_PIN16
DAI1_PIN17	DAI1 Pin 17	Not Muxed	DAI1_PIN17
DAI1_PIN18	DAI1 Pin 18	Not Muxed	DAI1_PIN18
DAI1_PIN19	DAI1 Pin 19	Not Muxed	DAI1_PIN19
DAI1_PIN20	DAI1 Pin 20	Not Muxed	DAI1_PIN20
DMC0_A00	DMC0 Address 0	Not Muxed	DMC0_A00
DMC0_A01	DMC0 Address 1	Not Muxed	DMC0_A01
DMC0_A02	DMC0 Address 2	Not Muxed	DMC0_A02
DMC0_A03	DMC0 Address 3	Not Muxed	DMC0_A03
DMC0_A04	DMC0 Address 4	Not Muxed	DMC0_A04
DMC0_A05	DMC0 Address 5	Not Muxed	DMC0_A05
DMC0_A06	DMC0 Address 6	Not Muxed	DMC0_A06
DMC0_A07	DMC0 Address 7	Not Muxed	DMC0_A07
DMC0_A08	DMC0 Address 8	Not Muxed	DMC0_A08
DMC0_A09	DMC0 Address 9	Not Muxed	DMC0_A09
DMC0_A10	DMC0 Address 10	Not Muxed	DMC0_A10
DMC0_A11	DMC0 Address 11	Not Muxed	DMC0_A11
DMC0_A12	DMC0 Address 12	Not Muxed	DMC0_A12
DMC0_A13	DMC0 Address 13	Not Muxed	DMC0_A13
DMC0_A14	DMC0 Address 14	Not Muxed	DMC0_A14
DMC0_A15	DMC0 Address 15	Not Muxed	DMC0_A15
DMC0_BA0	DMC0 Bank Address 0	Not Muxed	DMC0_BA0
DMC0_BA1	DMC0 Bank Address 1	Not Muxed	DMC0_BA1
DMC0_BA2	DMC0 Bank Address 2	Not Muxed	DMC0_BA2
DMC0_CAS	DMC0 Column Address Strobe	Not Muxed	DMC0_CAS
DMC0_CK	DMC0 Clock	Not Muxed	DMC0_CK
DMC0_CKE	DMC0 Clock Enable	Not Muxed	DMC0_CKE

ADSP-SC582/SC583/SC584/SC587/SC589/ADSP-21583/21584/21587

Table 19. ADSP-SC58x/ADSP-2158x 529-Ball CSP_BGA Signal Descriptions (Continued)

Signal Name	Description	Port	Pin Name
DMC0_CK	DMC0 Clock (Complement)	Not Muxed	DMC0_CK
DMC0_CS0	DMC0 Chip Select 0	Not Muxed	DMC0_CS0
DMC0_DQ00	DMC0 Data 0	Not Muxed	DMC0_DQ00
DMC0_DQ01	DMC0 Data 1	Not Muxed	DMC0_DQ01
DMC0_DQ02	DMC0 Data 2	Not Muxed	DMC0_DQ02
DMC0_DQ03	DMC0 Data 3	Not Muxed	DMC0_DQ03
DMC0_DQ04	DMC0 Data 4	Not Muxed	DMC0_DQ04
DMC0_DQ05	DMC0 Data 5	Not Muxed	DMC0_DQ05
DMC0_DQ06	DMC0 Data 6	Not Muxed	DMC0_DQ06
DMC0_DQ07	DMC0 Data 7	Not Muxed	DMC0_DQ07
DMC0_DQ08	DMC0 Data 8	Not Muxed	DMC0_DQ08
DMC0_DQ09	DMC0 Data 9	Not Muxed	DMC0_DQ09
DMC0_DQ10	DMC0 Data 10	Not Muxed	DMC0_DQ10
DMC0_DQ11	DMC0 Data 11	Not Muxed	DMC0_DQ11
DMC0_DQ12	DMC0 Data 12	Not Muxed	DMC0_DQ12
DMC0_DQ13	DMC0 Data 13	Not Muxed	DMC0_DQ13
DMC0_DQ14	DMC0 Data 14	Not Muxed	DMC0_DQ14
DMC0_DQ15	DMC0 Data 15	Not Muxed	DMC0_DQ15
DMC0_LDM	DMC0 Data Mask for Lower Byte	Not Muxed	DMC0_LDM
DMC0_LDQS	DMC0 Data Strobe for Lower Byte	Not Muxed	DMC0_LDQS
DMC0_LDQS	DMC0 Data Strobe for Lower Byte (Complement)	Not Muxed	DMC0_LDQS
DMC0_ODT	DMC0 On-Die Termination	Not Muxed	DMC0_ODT
DMC0_RAS	DMC0 Row Address Strobe	Not Muxed	DMC0_RAS
DMC0_RESET	DMC0 Reset (DDR3 Only)	Not Muxed	DMC0_RESET
DMC0_RZQ	DMC0 External Calibration Resistor Connection	Not Muxed	DMC0_RZQ
DMC0_UDM	DMC0 Data Mask for Upper Byte	Not Muxed	DMC0_UDM
DMC0_UDQS	DMC0 Data Strobe for Upper Byte	Not Muxed	DMC0_UDQS
DMC0_UDQS	DMC0 Data Strobe for Upper Byte (Complement)	Not Muxed	DMC0_UDQS
DMC0_VREF	DMC0 Voltage Reference	Not Muxed	DMC0_VREF
DMC0_WE	DMC0 Write Enable	Not Muxed	DMC0_WE
DMC1_A00	DMC1 Address 0	Not Muxed	DMC1_A00
DMC1_A01	DMC1 Address 1	Not Muxed	DMC1_A01
DMC1_A02	DMC1 Address 2	Not Muxed	DMC1_A02
DMC1_A03	DMC1 Address 3	Not Muxed	DMC1_A03
DMC1_A04	DMC1 Address 4	Not Muxed	DMC1_A04
DMC1_A05	DMC1 Address 5	Not Muxed	DMC1_A05
DMC1_A06	DMC1 Address 6	Not Muxed	DMC1_A06
DMC1_A07	DMC1 Address 7	Not Muxed	DMC1_A07
DMC1_A08	DMC1 Address 8	Not Muxed	DMC1_A08
DMC1_A09	DMC1 Address 9	Not Muxed	DMC1_A09
DMC1_A10	DMC1 Address 10	Not Muxed	DMC1_A10
DMC1_A11	DMC1 Address 11	Not Muxed	DMC1_A11
DMC1_A12	DMC1 Address 12	Not Muxed	DMC1_A12
DMC1_A13	DMC1 Address 13	Not Muxed	DMC1_A13
DMC1_A14	DMC1 Address 14	Not Muxed	DMC1_A14
DMC1_A15	DMC1 Address 15	Not Muxed	DMC1_A15
DMC1_BA0	DMC1 Bank Address 0	Not Muxed	DMC1_BA0
DMC1_BA1	DMC1 Bank Address 1	Not Muxed	DMC1_BA1

ADSP-SC582/SC583/SC584/SC587/SC589/ADSP-21583/21584/21587

Table 19. ADSP-SC58x/ADSP-2158x 529-Ball CSP_BGA Signal Descriptions (Continued)

Signal Name	Description	Port	Pin Name
DMC1_BA2	DMC1 Bank Address 2	Not Muxed	DMC1_BA2
$\overline{\text{DMC1_CAS}}$	DMC1 Column Address Strobe	Not Muxed	$\overline{\text{DMC1_CAS}}$
DMC1_CK	DMC1 Clock	Not Muxed	DMC1_CK
DMC1_CKE	DMC1 Clock Enable	Not Muxed	DMC1_CKE
$\overline{\text{DMC1_CK}}$	DMC1 Clock (Complement)	Not Muxed	$\overline{\text{DMC1_CK}}$
$\overline{\text{DMC1_CS0}}$	DMC1 Chip Select 0	Not Muxed	$\overline{\text{DMC1_CS0}}$
DMC1_DQ00	DMC1 Data 0	Not Muxed	DMC1_DQ00
DMC1_DQ01	DMC1 Data 1	Not Muxed	DMC1_DQ01
DMC1_DQ02	DMC1 Data 2	Not Muxed	DMC1_DQ02
DMC1_DQ03	DMC1 Data 3	Not Muxed	DMC1_DQ03
DMC1_DQ04	DMC1 Data 4	Not Muxed	DMC1_DQ04
DMC1_DQ05	DMC1 Data 5	Not Muxed	DMC1_DQ05
DMC1_DQ06	DMC1 Data 6	Not Muxed	DMC1_DQ06
DMC1_DQ07	DMC1 Data 7	Not Muxed	DMC1_DQ07
DMC1_DQ08	DMC1 Data 8	Not Muxed	DMC1_DQ08
DMC1_DQ09	DMC1 Data 9	Not Muxed	DMC1_DQ09
DMC1_DQ10	DMC1 Data 10	Not Muxed	DMC1_DQ10
DMC1_DQ11	DMC1 Data 11	Not Muxed	DMC1_DQ11
DMC1_DQ12	DMC1 Data 12	Not Muxed	DMC1_DQ12
DMC1_DQ13	DMC1 Data 13	Not Muxed	DMC1_DQ13
DMC1_DQ14	DMC1 Data 14	Not Muxed	DMC1_DQ14
DMC1_DQ15	DMC1 Data 15	Not Muxed	DMC1_DQ15
DMC1_LDM	DMC1 Data Mask for Lower Byte	Not Muxed	DMC1_LDM
DMC1_LDQS	DMC1 Data Strobe for Lower Byte	Not Muxed	DMC1_LDQS
$\overline{\text{DMC1_LDQS}}$	DMC1 Data Strobe for Lower Byte (Complement)	Not Muxed	$\overline{\text{DMC1_LDQS}}$
DMC1_ODT	DMC1 On-Die Termination	Not Muxed	DMC1_ODT
$\overline{\text{DMC1_RAS}}$	DMC1 Row Address Strobe	Not Muxed	$\overline{\text{DMC1_RAS}}$
$\overline{\text{DMC1_RESET}}$	DMC1 Reset (DDR3 Only)	Not Muxed	$\overline{\text{DMC1_RESET}}$
DMC1_RZQ	DMC1 External Calibration Resistor Connection	Not Muxed	DMC1_RZQ
DMC1_UDM	DMC1 Data Mask for Upper Byte	Not Muxed	DMC1_UDM
DMC1_UDQS	DMC1 Data Strobe for Upper Byte	Not Muxed	DMC1_UDQS
$\overline{\text{DMC1_UDQS}}$	DMC1 Data Strobe for Upper Byte (Complement)	Not Muxed	$\overline{\text{DMC1_UDQS}}$
DMC1_VREF	DMC1 Voltage Reference	Not Muxed	DMC1_VREF
$\overline{\text{DMC1_WE}}$	DMC1 Write Enable	Not Muxed	$\overline{\text{DMC1_WE}}$
ETH0_CRS	ETH0 Carrier Sense/RMII Receive Data Valid	A	PA_07
ETH0_MDC	ETH0 Management Channel Clock	A	PA_02
ETH0_MDIO	ETH0 Management Channel Serial Data	A	PA_03
ETH0_PTPAUXIN0	ETH0 PTP Auxiliary Trigger Input 0	B	PB_03
ETH0_PTPAUXIN1	ETH0 PTP Auxiliary Trigger Input 1	B	PB_04
ETH0_PTPAUXIN2	ETH0 PTP Auxiliary Trigger Input 2	B	PB_05
ETH0_PTPAUXIN3	ETH0 PTP Auxiliary Trigger Input 3	B	PB_06
ETH0_PTPCLKIN0	ETH0 PTP Clock Input 0	B	PB_02
ETH0_PTPPPS0	ETH0 PTP Pulse-Per-Second Output 0	B	PB_01
ETH0_PTPPPS1	ETH0 PTP Pulse-Per-Second Output 1	B	PB_00
ETH0_PTPPPS2	ETH0 PTP Pulse-Per-Second Output 2	A	PA_15
ETH0_PTPPPS3	ETH0 PTP Pulse-Per-Second Output 3	A	PA_14
ETH0_RXCLK_REFCLK	ETH0 RXCLK (10/100/1000) or REFCLK (10/100)	A	PA_06
ETH0_RXCTL_CRS	ETH0 RXCTL (10/100/1000) or CRS (10/100)	A	PA_07

ADSP-SC582/SC583/SC584/SC587/SC589/ADSP-21583/21584/21587

Table 19. ADSP-SC58x/ADSP-2158x 529-Ball CSP_BGA Signal Descriptions (Continued)

Signal Name	Description	Port	Pin Name
ETH0_RXD0	ETH0 Receive Data 0	A	PA_04
ETH0_RXD1	ETH0 Receive Data 1	A	PA_05
ETH0_RXD2	ETH0 Receive Data 2	A	PA_08
ETH0_RXD3	ETH0 Receive Data 3	A	PA_09
ETH0_TXCLK	ETH0 Transmit Clock	A	PA_11
ETH0_TXCTL_TXEN	ETH0 TXCTL (10/100/1000) or TXEN (10/100)	A	PA_10
ETH0_TXD0	ETH0 Transmit Data 0	A	PA_00
ETH0_TXD1	ETH0 Transmit Data 1	A	PA_01
ETH0_TXD2	ETH0 Transmit Data 2	A	PA_12
ETH0_TXD3	ETH0 Transmit Data 3	A	PA_13
ETH0_TXEN	ETH0 Transmit Enable	A	PA_10
ETH1_CRS	ETH1 Carrier Sense/RMII Receive Data Valid	F	PF_13
ETH1_MDC	ETH1 Management Channel Clock	F	PF_14
ETH1_MDIO	ETH1 Management Channel Serial Data	F	PF_15
ETH1_REFCLK	ETH1 Reference Clock	G	PG_00
ETH1_RXD0	ETH1 Receive Data 0	G	PG_04
ETH1_RXD1	ETH1 Receive Data 1	G	PG_05
ETH1_TXD0	ETH1 Transmit Data 0	G	PG_02
ETH1_TXD1	ETH1 Transmit Data 1	G	PG_03
ETH1_TXEN	ETH1 Transmit Enable	G	PG_01
HADC0_EOC_DOUT	HADC0 End of Conversion/Serial Data Out	F	PF_02
HADC0_MUX0	HADC0 Controls to External Multiplexer	F	PF_05
HADC0_MUX1	HADC0 Controls to External Multiplexer	F	PF_04
HADC0_MUX2	HADC0 Controls to External Multiplexer	F	PF_03
HADC0_VIN0	HADC0 Analog Input at Channel 0	Not Muxed	HADC0_VIN0
HADC0_VIN1	HADC0 Analog Input at Channel 1	Not Muxed	HADC0_VIN1
HADC0_VIN2	HADC0 Analog Input at Channel 2	Not Muxed	HADC0_VIN2
HADC0_VIN3	HADC0 Analog Input at Channel 3	Not Muxed	HADC0_VIN3
HADC0_VIN4	HADC0 Analog Input at Channel 4	Not Muxed	HADC0_VIN4
HADC0_VIN5	HADC0 Analog Input at Channel 5	Not Muxed	HADC0_VIN5
HADC0_VIN6	HADC0 Analog Input at Channel 6	Not Muxed	HADC0_VIN6
HADC0_VIN7	HADC0 Analog Input at Channel 7	Not Muxed	HADC0_VIN7
HADC0_VREFN	HADC0 Ground Reference for ADC	Not Muxed	HADC0_VREFN
HADC0_VREFP	HADC0 External Reference for ADC	Not Muxed	HADC0_VREFP
JTG_TCK	TAPC JTAG Clock	Not Muxed	JTG_TCK
JTG_TDI	TAPC JTAG Serial Data In	Not Muxed	JTG_TDI
JTG_TDO	TAPC JTAG Serial Data Out	Not Muxed	JTG_TDO
JTG_TMS	TAPC JTAG Mode Select	Not Muxed	JTG_TMS
JTG_TRST	TAPC JTAG Reset	Not Muxed	JTG_TRST
LP0_ACK	LP0 Acknowledge	D	PD_11
LP0_CLK	LP0 Clock	D	PD_10
LP0_D0	LP0 Data 0	D	PD_02
LP0_D1	LP0 Data 1	D	PD_03
LP0_D2	LP0 Data 2	D	PD_04
LP0_D3	LP0 Data 3	D	PD_05
LP0_D4	LP0 Data 4	D	PD_06
LP0_D5	LP0 Data 5	D	PD_07
LP0_D6	LP0 Data 6	D	PD_08

ADSP-SC582/SC583/SC584/SC587/SC589/ADSP-21583/21584/21587

Table 19. ADSP-SC58x/ADSP-2158x 529-Ball CSP_BGA Signal Descriptions (Continued)

Signal Name	Description	Port	Pin Name
LP0_D7	LP0 Data 7	D	PD_09
LP1_ACK	LP1 Acknowledge	B	PB_15
LP1_CLK	LP1 Clock	C	PC_00
LP1_D0	LP1 Data 0	B	PB_07
LP1_D1	LP1 Data 1	B	PB_08
LP1_D2	LP1 Data 2	B	PB_09
LP1_D3	LP1 Data 3	B	PB_10
LP1_D4	LP1 Data 4	B	PB_11
LP1_D5	LP1 Data 5	B	PB_12
LP1_D6	LP1 Data 6	B	PB_13
LP1_D7	LP1 Data 7	B	PB_14
MLB0_CLKN	MLB0 Differential Clock (-)	Not Muxed	MLB0_CLKN
MLB0_CLKP	MLB0 Differential Clock (+)	Not Muxed	MLB0_CLKP
MLB0_DATN	MLB0 Differential Data (-)	Not Muxed	MLB0_DATN
MLB0_DATP	MLB0 Differential Data (+)	Not Muxed	MLB0_DATP
MLB0_SIGN	MLB0 Differential Signal (-)	Not Muxed	MLB0_SIGN
MLB0_SIGP	MLB0 Differential Signal (+)	Not Muxed	MLB0_SIGP
MLB0_CLK	MLB0 Single-Ended Clock	B	PB_04
MLB0_DAT	MLB0 Single-Ended Data	B	PB_06
MLB0_SIG	MLB0 Single-Ended Signal	B	PB_05
MLB0_CLKOUT	MLB0 Single-Ended Clock Out	D	PD_14
MSIO_CD	MSIO Card Detect	F	PF_12
MSIO_CLK	MSIO Clock	F	PF_11
MSIO_CMD	MSIO Command	F	PF_10
MSIO_D0	MSIO Data 0	F	PF_02
MSIO_D1	MSIO Data 1	F	PF_03
MSIO_D2	MSIO Data 2	F	PF_04
MSIO_D3	MSIO Data 3	F	PF_05
MSIO_D4	MSIO Data 4	F	PF_06
MSIO_D5	MSIO Data 5	F	PF_07
MSIO_D6	MSIO Data 6	F	PF_08
MSIO_D7	MSIO Data 7	F	PF_09
MSIO_INT	MSIO eSDIO Interrupt Input	F	PF_13
PA_00-15	PORTA Position 00 Through Position 15	A	PA_00-15
PB_00-15	PORTB Position 00 Through Position 15	B	PB_00-15
PCIE0_CLKM	PCIE0 CLK -	Not Muxed	PCIE0_CLKM
PCIE0_CLKP	PCIE0 CLK +	Not Muxed	PCIE0_CLKP
PCIE0_REF	PCIE0 Reference	Not Muxed	PCIE0_REF
PCIE0_RXM	PCIE0 RX -	Not Muxed	PCIE0_RXM
PCIE0_RXP	PCIE0 RX +	Not Muxed	PCIE0_RXP
PCIE0_TXM	PCIE0 TX -	Not Muxed	PCIE0_TXM
PCIE0_TXP	PCIE0 TX +	Not Muxed	PCIE0_TXP
PC_00-15	PORTC Position 00 Through Position 15	C	PC_00-15
PD_00-15	PORTD Position 00 Through Position 15	D	PD_00-15
PE_00-15	PORTE Position 00 Through Position 15	E	PE_00-15
PF_00-15	PORTF Position 00 Through Position 15	F	PF_00-15
PG_00-5	PORTG Position 00 Through Position 5	G	PG_00-5
PPIO_CLK	EPPIO Clock	E	PE_03

ADSP-SC582/SC583/SC584/SC587/SC589/ADSP-21583/21584/21587

Table 19. ADSP-SC58x/ADSP-2158x 529-Ball CSP_BGA Signal Descriptions (Continued)

Signal Name	Description	Port	Pin Name
PPIO_D00	EPPIO Data 0	E	PE_12
PPIO_D01	EPPIO Data 1	E	PE_11
PPIO_D02	EPPIO Data 2	E	PE_10
PPIO_D03	EPPIO Data 3	E	PE_09
PPIO_D04	EPPIO Data 4	E	PE_08
PPIO_D05	EPPIO Data 5	E	PE_07
PPIO_D06	EPPIO Data 6	E	PE_06
PPIO_D07	EPPIO Data 7	E	PE_05
PPIO_D08	EPPIO Data 8	E	PE_04
PPIO_D09	EPPIO Data 9	E	PE_00
PPIO_D10	EPPIO Data 10	D	PD_15
PPIO_D11	EPPIO Data 11	D	PD_14
PPIO_D12	EPPIO Data 12	B	PB_04
PPIO_D13	EPPIO Data 13	B	PB_05
PPIO_D14	EPPIO Data 14	B	PB_00
PPIO_D15	EPPIO Data 15	B	PB_01
PPIO_D16	EPPIO Data 16	B	PB_02
PPIO_D17	EPPIO Data 17	B	PB_03
PPIO_D18	EPPIO Data 18	D	PD_13
PPIO_D19	EPPIO Data 19	D	PD_12
PPIO_D20	EPPIO Data 20	E	PE_13
PPIO_D21	EPPIO Data 21	E	PE_14
PPIO_D22	EPPIO Data 22	E	PE_15
PPIO_D23	EPPIO Data 23	D	PD_00
PPIO_FS1	EPPIO Frame Sync 1 (HSYNC)	E	PE_02
PPIO_FS2	EPPIO Frame Sync 2 (VSYNC)	E	PE_01
PPIO_FS3	EPPIO Frame Sync 3 (FIELD)	C	PC_15
PWM0_AH	PWM0 Channel A High Side	B	PB_07
PWM0_AL	PWM0 Channel A Low Side	B	PB_08
PWM0_BH	PWM0 Channel B High Side	B	PB_06
PWM0_BL	PWM0 Channel B Low Side	C	PC_00
PWM0_CH	PWM0 Channel C High Side	B	PB_13
PWM0_CL	PWM0 Channel C Low Side	B	PB_14
PWM0_DH	PWM0 Channel D High Side	B	PB_11
PWM0_DL	PWM0 Channel D Low Side	B	PB_12
PWM0_SYNC	PWM0 PWMTMR Grouped	E	PE_09
PWM0_TRIP0	PWM0 Shutdown Input 0	B	PB_15
PWM1_AH	PWM1 Channel A High Side	D	PD_03
PWM1_AL	PWM1 Channel A Low Side	D	PD_04
PWM1_BH	PWM1 Channel B High Side	D	PD_05
PWM1_BL	PWM1 Channel B Low Side	D	PD_06
PWM1_CH	PWM1 Channel C High Side	D	PD_07
PWM1_CL	PWM1 Channel C Low Side	D	PD_08
PWM1_DH	PWM1 Channel D High Side	D	PD_09
PWM1_DL	PWM1 Channel D Low Side	D	PD_10
PWM1_SYNC	PWM1 PWMTMR Grouped	D	PD_11
PWM1_TRIP0	PWM1 Shutdown Input 0	D	PD_02
PWM2_AH	PWM2 Channel A High Side	F	PF_07

ADSP-SC582/SC583/SC584/SC587/SC589/ADSP-21583/21584/21587

Table 19. ADSP-SC58x/ADSP-2158x 529-Ball CSP_BGA Signal Descriptions (Continued)

Signal Name	Description	Port	Pin Name
PWM2_AL	PWM2 Channel A Low Side	F	PF_06
PWM2_BH	PWM2 Channel B High Side	F	PF_09
PWM2_BL	PWM2 Channel B Low Side	F	PF_08
PWM2_CH	PWM2 Channel C High Side	D	PD_15
PWM2_CL	PWM2 Channel C Low Side	E	PE_00
PWM2_DH	PWM2 Channel D High Side	E	PE_04
PWM2_DL	PWM2 Channel D Low Side	E	PE_10
PWM2_SYNC	PWM2 PWMTMR Grouped	E	PE_05
PWM2_TRIP0	PWM2 Shutdown Input 0	D	PD_14
GND	Ground	Not Muxed	GND
VDD_EXT	External Voltage Domain	Not Muxed	VDD_EXT
VDD_INT	Internal Voltage Domain	Not Muxed	VDD_INT
RTC0_CLKIN	RTC0 Crystal Input/External Oscillator Connection	Not Muxed	RTC0_CLKIN
RTC0_XTAL	RTC0 Crystal Output	Not Muxed	RTC0_XTAL
SINC0_CLK0	SINC0 Clock 0	B	PB_01
SINC0_D0	SINC0 Data 0	A	PA_14
SINC0_D1	SINC0 Data 1	A	PA_15
SINC0_D2	SINC0 Data 2	B	PB_00
SINC0_D3	SINC0 Data 3	B	PB_04
SMC0_A01	SMC0 Address 1	B	PB_05
SMC0_A02	SMC0 Address 2	B	PB_06
SMC0_A03	SMC0 Address 3	B	PB_03
SMC0_A04	SMC0 Address 4	B	PB_02
SMC0_A05	SMC0 Address 5	D	PD_13
SMC0_A06	SMC0 Address 6	D	PD_12
SMC0_A07	SMC0 Address 7	B	PB_01
SMC0_A08	SMC0 Address 8	B	PB_00
SMC0_A09	SMC0 Address 9	A	PA_15
SMC0_A10	SMC0 Address 10	A	PA_14
SMC0_A11	SMC0 Address 11	A	PA_09
SMC0_A12	SMC0 Address 12	A	PA_08
SMC0_A13	SMC0 Address 13	A	PA_13
SMC0_A14	SMC0 Address 14	A	PA_12
SMC0_A15	SMC0 Address 15	A	PA_11
SMC0_A16	SMC0 Address 16	A	PA_07
SMC0_A17	SMC0 Address 17	A	PA_06
SMC0_A18	SMC0 Address 18	A	PA_05
SMC0_A19	SMC0 Address 19	A	PA_04
SMC0_A20	SMC0 Address 20	A	PA_01
SMC0_A21	SMC0 Address 21	A	PA_00
SMC0_A22	SMC0 Address 22	A	PA_10
SMC0_A23	SMC0 Address 23	A	PA_03
SMC0_A24	SMC0 Address 24	A	PA_02
SMC0_A25	SMC0 Address 25	C	PC_12
SMC0_ABE0	SMC0 Byte Enable 0	E	PE_14
SMC0_ABE1	SMC0 Byte Enable 1	E	PE_15
SMC0_AMS0	SMC0 Memory Select 0	C	PC_15
SMC0_AMS1	SMC0 Memory Select 1	E	PE_13

ADSP-SC582/SC583/SC584/SC587/SC589/ADSP-21583/21584/21587

Table 19. ADSP-SC58x/ADSP-2158x 529-Ball CSP_BGA Signal Descriptions (Continued)

Signal Name	Description	Port	Pin Name
$\overline{\text{SMC0_AMS2}}$	SMC0 Memory Select 2	C	PC_07
$\overline{\text{SMC0_AMS3}}$	SMC0 Memory Select 3	C	PC_08
$\overline{\text{SMC0_AOE}}$	SMC0 Output Enable	D	PD_01
SMC0_ARDY	SMC0 Asynchronous Ready	B	PB_04
$\overline{\text{SMC0_ARE}}$	SMC0 Read Enable	C	PC_00
$\overline{\text{SMC0_AWE}}$	SMC0 Write Enable	B	PB_15
SMC0_D00	SMC0 Data 0	E	PE_12
SMC0_D01	SMC0 Data 1	E	PE_11
SMC0_D02	SMC0 Data 2	E	PE_10
SMC0_D03	SMC0 Data 3	E	PE_09
SMC0_D04	SMC0 Data 4	E	PE_00
SMC0_D05	SMC0 Data 5	D	PD_15
SMC0_D06	SMC0 Data 6	D	PD_14
SMC0_D07	SMC0 Data 7	D	PD_00
SMC0_D08	SMC0 Data 8	B	PB_14
SMC0_D09	SMC0 Data 9	B	PB_13
SMC0_D10	SMC0 Data 10	B	PB_12
SMC0_D11	SMC0 Data 11	B	PB_11
SMC0_D12	SMC0 Data 12	B	PB_10
SMC0_D13	SMC0 Data 13	B	PB_09
SMC0_D14	SMC0 Data 14	B	PB_08
SMC0_D15	SMC0 Data 15	B	PB_07
SPI0_CLK	SPI0 Clock	C	PC_09
SPI0_MISO	SPI0 Master In, Slave Out	C	PC_10
SPI0_MOSI	SPI0 Master Out, Slave In	C	PC_11
SPI0_RDY	SPI0 Ready	C	PC_12
$\overline{\text{SPI0_SEL1}}$	SPI0 Slave Select Output 1	C	PC_07
$\overline{\text{SPI0_SEL2}}$	SPI0 Slave Select Output 2	D	PD_01
$\overline{\text{SPI0_SEL3}}$	SPI0 Slave Select Output 3	C	PC_12
$\overline{\text{SPI0_SEL4}}$	SPI0 Slave Select Output 4	C	PC_00
$\overline{\text{SPI0_SEL5}}$	SPI0 Slave Select Output 5	E	PE_01
$\overline{\text{SPI0_SEL6}}$	SPI0 Slave Select Output 6	E	PE_02
$\overline{\text{SPI0_SEL7}}$	SPI0 Slave Select Output 7	E	PE_03
$\overline{\text{SPI0_SS}}$	SPI0 Slave Select Input	D	PD_01
SPI1_CLK	SPI1 Clock	E	PE_13
SPI1_MISO	SPI1 Master In, Slave Out	E	PE_14
SPI1_MOSI	SPI1 Master Out, Slave In	E	PE_15
SPI1_RDY	SPI1 Ready	E	PE_08
$\overline{\text{SPI1_SEL1}}$	SPI1 Slave Select Output 1	C	PC_13
$\overline{\text{SPI1_SEL2}}$	SPI1 Slave Select Output 2	E	PE_07
$\overline{\text{SPI1_SEL3}}$	SPI1 Slave Select Output 3	E	PE_11
$\overline{\text{SPI1_SEL4}}$	SPI1 Slave Select Output 4	E	PE_12
$\overline{\text{SPI1_SEL5}}$	SPI1 Slave Select Output 5	E	PE_08
$\overline{\text{SPI1_SEL6}}$	SPI1 Slave Select Output 6	F	PF_00
$\overline{\text{SPI1_SEL7}}$	SPI1 Slave Select Output 7	F	PF_01
$\overline{\text{SPI1_SS}}$	SPI1 Slave Select Input	E	PE_11
SPI2_CLK	SPI2 Clock	C	PC_01
SPI2_D2	SPI2 Data 2	C	PC_04

ADSP-SC582/SC583/SC584/SC587/SC589/ADSP-21583/21584/21587

Table 19. ADSP-SC58x/ADSP-2158x 529-Ball CSP_BGA Signal Descriptions (Continued)

Signal Name	Description	Port	Pin Name
SPI2_D3	SPI2 Data 3	C	PC_05
SPI2_MISO	SPI2 Master In, Slave Out	C	PC_02
SPI2_MOSI	SPI2 Master Out, Slave In	C	PC_03
SPI2_RDY	SPI2 Ready	E	PE_12
$\overline{\text{SPI2_SEL1}}$	SPI2 Slave Select Output 1	C	PC_06
$\overline{\text{SPI2_SEL2}}$	SPI2 Slave Select Output 2	E	PE_03
$\overline{\text{SPI2_SEL3}}$	SPI2 Slave Select Output 3	E	PE_04
$\overline{\text{SPI2_SEL4}}$	SPI2 Slave Select Output 4	E	PE_05
$\overline{\text{SPI2_SEL5}}$	SPI2 Slave Select Output 5	E	PE_06
$\overline{\text{SPI2_SS}}$	SPI2 Slave Select Input	C	PC_06
SYS_BMODE0	Boot Mode Control 0	Not Muxed	SYS_BMODE0
SYS_BMODE1	Boot Mode Control 1	Not Muxed	SYS_BMODE1
SYS_BMODE2	Boot Mode Control 2	Not Muxed	SYS_BMODE2
SYS_CLKIN0	Clock/Crystal Input	Not Muxed	SYS_CLKIN0
SYS_CLKIN1	Clock/Crystal Input	Not Muxed	SYS_CLKIN1
SYS_CLKOUT	Processor Clock Output	Not Muxed	SYS_CLKOUT
SYS_FAULT	Active High Fault Output	Not Muxed	SYS_FAULT
$\overline{\text{SYS_FAULT}}$	Active Low Fault Output	Not Muxed	$\overline{\text{SYS_FAULT}}$
SYS_HWRST	Processor Hardware Reset Control	Not Muxed	SYS_HWRST
$\overline{\text{SYS_RESOUT}}$	Reset Output	Not Muxed	$\overline{\text{SYS_RESOUT}}$
SYS_XTAL0	Crystal Output	Not Muxed	SYS_XTAL0
SYS_XTAL1	Crystal Output	Not Muxed	SYS_XTAL1
TM0_ACIO	TIMER0 Alternate Capture Input 0	C	PC_14
TM0_AC11	TIMER0 Alternate Capture Input 1	B	PB_03
TM0_AC12	TIMER0 Alternate Capture Input 2	D	PD_13
TM0_AC13	TIMER0 Alternate Capture Input 3	C	PC_07
TM0_AC14	TIMER0 Alternate Capture Input 4	B	PB_10
TM0_ACLK1	TIMER0 Alternate Clock 1	D	PD_08
TM0_ACLK2	TIMER0 Alternate Clock 2	D	PD_09
TM0_ACLK3	TIMER0 Alternate Clock 3	B	PB_00
TM0_ACLK4	TIMER0 Alternate Clock 4	B	PB_01
TM0_CLK	TIMER0 Clock	C	PC_11
TM0_TMR0	TIMER0 Timer 0	E	PE_09
TM0_TMR1	TIMER0 Timer 1	B	PB_15
TM0_TMR2	TIMER0 Timer 2	B	PB_10
TM0_TMR3	TIMER0 Timer 3	B	PB_07
TM0_TMR4	TIMER0 Timer 4	B	PB_08
TM0_TMR5	TIMER0 Timer 5	B	PB_14
TM0_TMR6	TIMER0 Timer 6	F	PF_00
TM0_TMR7	TIMER0 Timer 7	F	PF_01
TRACE0_CLK	TRACE0 Trace Clock (First Instance)	G	PG_00
$\overline{\text{TRACE0_CLK}}$	TRACE0 Trace Clock (Second Instance)	D	PD_10
TRACE0_D00	TRACE0 Trace Data (First Instance)	F	PF_13
$\overline{\text{TRACE0_D00}}$	TRACE0 Trace Data 0 (Second Instance)	D	PD_02
TRACE0_D01	TRACE0 Trace Data 1 (First Instance)	D	PD_03
$\overline{\text{TRACE0_D01}}$	TRACE0 Trace Data (Second Instance)	F	PF_14
TRACE0_D02	TRACE0 Trace Data (First Instance)	F	PF_15
$\overline{\text{TRACE0_D02}}$	TRACE0 Trace Data 2 (Second Instance)	D	PD_04

ADSP-SC582/SC583/SC584/SC587/SC589/ADSP-21583/21584/21587

Table 19. ADSP-SC58x/ADSP-2158x 529-Ball CSP_BGA Signal Descriptions (Continued)

Signal Name	Description	Port	Pin Name
TRACE0_D03	TRACE0 Trace Data (First Instance)	G	PG_01
TRACE0_D03	TRACE0 Trace Data 3 (Second Instance)	D	PD_05
TRACE0_D04	TRACE0 Trace Data (First Instance)	G	PG_02
TRACE0_D04	TRACE0 Trace Data 4 (Second Instance)	D	PD_06
TRACE0_D05	TRACE0 Trace Data 5 (First Instance)	D	PD_07
TRACE0_D05	TRACE0 Trace Data (Second Instance)	G	PG_03
TRACE0_D06	TRACE0 Trace Data (First Instance)	G	PG_04
TRACE0_D06	TRACE0 Trace Data 6 (Second Instance)	D	PD_08
TRACE0_D07	TRACE0 Trace Data (First Instance)	G	PG_05
TRACE0_D07	TRACE0 Trace Data 7 (Second Instance)	D	PD_09
TRACE0_D08	TRACE0 Trace Data 8	F	PF_13
TRACE0_D09	TRACE0 Trace Data 9	F	PF_14
TRACE0_D10	TRACE0 Trace Data 10	F	PF_15
TRACE0_D11	TRACE0 Trace Data 11	G	PG_01
TRACE0_D12	TRACE0 Trace Data 12	G	PG_02
TRACE0_D13	TRACE0 Trace Data 13	G	PG_03
TRACE0_D14	TRACE0 Trace Data 14	G	PG_04
TRACE0_D15	TRACE0 Trace Data 15	G	PG_05
TWI0_SCL	TWI0 Serial Clock	Not Muxed	TWI0_SCL
TWI0_SDA	TWI0 Serial Data	Not Muxed	TWI0_SDA
TWI1_SCL	TWI1 Serial Clock	Not Muxed	TWI1_SCL
TWI1_SDA	TWI1 Serial Data	Not Muxed	TWI1_SDA
TWI2_SCL	TWI2 Serial Clock	Not Muxed	TWI2_SCL
TWI2_SDA	TWI2 Serial Data	Not Muxed	TWI2_SDA
<u>UART0_CTS</u>	UART0 Clear to Send	D	PD_00
<u>UART0_RTS</u>	UART0 Request to Send	C	PC_15
<u>UART0_RX</u>	UART0 Receive	C	PC_14
<u>UART0_TX</u>	UART0 Transmit	C	PC_13
<u>UART1_CTS</u>	UART1 Clear to Send	E	PE_01
<u>UART1_RTS</u>	UART1 Request to Send	E	PE_02
<u>UART1_RX</u>	UART1 Receive	B	PB_03
<u>UART1_TX</u>	UART1 Transmit	B	PB_02
<u>UART2_CTS</u>	UART2 Clear to Send	E	PE_11
<u>UART2_RTS</u>	UART2 Request to Send	E	PE_10
<u>UART2_RX</u>	UART2 Receive	D	PD_13
<u>UART2_TX</u>	UART2 Transmit	D	PD_12
USB0_CLKIN	USB0 Clock/Crystal Input	Not Muxed	USB_CLKIN
USB0_DM	USB0 Data –	Not Muxed	USB0_DM
USB0_DP	USB0 Data +	Not Muxed	USB0_DP
USB0_ID	USB0 OTG ID	Not Muxed	USB0_ID
USB0_VBC	USB0 VBUS Control	Not Muxed	USB0_VBC
USB0_VBUS	USB0 Bus Voltage	Not Muxed	USB0_VBUS
USB0_XTAL	USB0 Crystal	Not Muxed	USB_XTAL
USB1_DM	USB1 Data –	Not Muxed	USB1_DM
USB1_DP	USB1 Data +	Not Muxed	USB1_DP
USB1_VBUS	USB1 Bus Voltage	Not Muxed	USB1_VBUS
VDD_DMC	DMC VDD	Not Muxed	VDD_DMC
VDD_HADC	HADC/TMU VDD	Not Muxed	VDD_HADC

ADSP-SC582/SC583/SC584/SC587/SC589/ADSP-21583/21584/21587

Table 19. ADSP-SC58x/ADSP-2158x 529-Ball CSP_BGA Signal Descriptions (Continued)

Signal Name	Description	Port	Pin Name
VDD_PCIE	PCIE Supply Voltage	Not Muxed	VDD_PCIE
VDD_PCIE_RX	PCIE RX Supply Voltage	Not Muxed	VDD_PCIE_RX
VDD_PCIE_TX	PCIE TX Supply Voltage	Not Muxed	VDD_PCIE_TX
VDD_RTC	RTC VDD	Not Muxed	VDD_RTC
VDD_USB	USB VDD	Not Muxed	VDD_USB

ADSP-SC582/SC583/SC584/SC587/SC589/ADSP-21583/21584/21587

GPIO MULTIPLEXING FOR THE 529-BALL CSP_BGA PACKAGE

Table 20 through Table 26 identify the pin functions that are multiplexed on the general-purpose I/O pins of the 529-ball CSP_BGA package.

Table 20. Signal Multiplexing for Port A

Signal Name	Multiplexed Function 0	Multiplexed Function 1	Multiplexed Function 2	Multiplexed Function 3	Multiplexed Function Input Tap
PA_00	ETH0_TXD0			SMC0_A21	
PA_01	ETH0_TXD1			SMC0_A20	
PA_02	ETH0_MDC			SMC0_A24	
PA_03	ETH0_MDIO			SMC0_A23	
PA_04	ETH0_RXD0			SMC0_A19	
PA_05	ETH0_RXD1			SMC0_A18	
PA_06	ETH0_RXCLK_REFCLK			SMC0_A17	
PA_07	ETH0_CRS			SMC0_A16	
PA_08	ETH0_RXD2			SMC0_A12	
PA_09	ETH0_RXD3			SMC0_A11	
PA_10	ETH0_TXEN			SMC0_A22	
PA_11	ETH0_TXCLK			SMC0_A15	
PA_12	ETH0_TXD2			SMC0_A14	
PA_13	ETH0_TXD3			SMC0_A13	
PA_14	ETH0_PTPPPS3	SINC0_D0		SMC0_A10	
PA_15	ETH0_PTPPPS2	SINC0_D1		SMC0_A09	

Table 21. Signal Multiplexing for Port B

Signal Name	Multiplexed Function 0	Multiplexed Function 1	Multiplexed Function 2	Multiplexed Function 3	Multiplexed Function Input Tap
PB_00	ETH0_PTPPPS1	SINC0_D2	PPIO_D14	SMC0_A08	TM0_ACLK3
PB_01	ETH0_PTPPPS0	SINC0_CLK0	PPIO_D15	SMC0_A07	TM0_ACLK4
PB_02	ETH0_PTPCLKINO	UART1_TX	PPIO_D16	SMC0_A04	
PB_03	ETH0_PTPAUXINO	UART1_RX	PPIO_D17	SMC0_A03	TM0_ACI1
PB_04	MLB0_CLK	SINC0_D3	PPIO_D12	SMC0_ARDY	ETH0_PTPAUXIN1
PB_05	MLB0_SIG		PPIO_D13	SMC0_A01	ETH0_PTPAUXIN2
PB_06	MLB0_DAT		PWM0_BH	SMC0_A02	ETH0_PTPAUXIN3
PB_07	LP1_D0	PWM0_AH	TM0_TMR3	SMC0_D15	
PB_08	LP1_D1	PWM0_AL	TM0_TMR4	SMC0_D14	
PB_09	LP1_D2		CAN1_TX	SMC0_D13	
PB_10	LP1_D3	TM0_TMR2	CAN1_RX	SMC0_D12	TM0_ACI4
PB_11	LP1_D4		PWM0_DH	SMC0_D11	CNT0_ZM
PB_12	LP1_D5		PWM0_DL	SMC0_D10	CNT0_UD
PB_13	LP1_D6		PWM0_CH	SMC0_D09	
PB_14	LP1_D7	TM0_TMR5	PWM0_CL	SMC0_D08	CNT0_DG
PB_15	LP1_ACK	PWM0_TRIP0	TM0_TMR1	SMC0_AWE	

ADSP-SC582/SC583/SC584/SC587/SC589/ADSP-21583/21584/21587

Table 22. Signal Multiplexing for Port C

Signal Name	Multiplexed Function 0	Multiplexed Function 1	Multiplexed Function 2	Multiplexed Function 3	Multiplexed Function Input Tap
PC_00	LP1_CLK	PWM0_BL	SPIO_SEL4	SMC0_ARE	
PC_01	SPI2_CLK				
PC_02	SPI2_MISO				
PC_03	SPI2_MOSI				
PC_04	SPI2_D2				
PC_05	SPI2_D3				
PC_06	SPI2_SEL1				SPI2_SS
PC_07	CAN0_RX	SPIO_SEL1		SMC0_AMS2	TM0_AC13
PC_08	CAN0_TX			SMC0_AMS3	
PC_09	SPIO_CLK				
PC_10	SPIO_MISO				
PC_11	SPIO_MOSI				TM0_CLK
PC_12	SPIO_SEL3	SPIO_RDY	ACM0_T0	SMC0_A25	
PC_13	UART0_TX	SPI1_SEL1	ACM0_A0		
PC_14	UART0_RX		ACM0_A1		TM0_AC10
PC_15	UART0_RTS	PPIO_FS3	ACM0_A2	SMC0_AMS0	

Table 23. Signal Multiplexing for Port D

Signal Name	Multiplexed Function 0	Multiplexed Function 1	Multiplexed Function 2	Multiplexed Function 3	Multiplexed Function Input Tap
PD_00	UART0_CTS	PPIO_D23	ACM0_A3	SMC0_D07	
PD_01	SPIO_SEL2		ACM0_A4	SMC0_AOE	SPIO_SS
PD_02	LP0_D0	PWM1_TRIP0	TRACE0_D00		
PD_03	LP0_D1	PWM1_AH	TRACE0_D01		
PD_04	LP0_D2	PWM1_AL	TRACE0_D02		
PD_05	LP0_D3	PWM1_BH	TRACE0_D03		
PD_06	LP0_D4	PWM1_BL	TRACE0_D04		
PD_07	LP0_D5	PWM1_CH	TRACE0_D05		
PD_08	LP0_D6	PWM1_CL	TRACE0_D06		TM0_ACLK1
PD_09	LP0_D7	PWM1_DH	TRACE0_D07		TM0_ACLK2
PD_10	LP0_CLK	PWM1_DL	TRACE0_CLK		
PD_11	LP0_ACK	PWM1_SYNC			
PD_12	UART2_TX		PPIO_D19	SMC0_A06	
PD_13	UART2_RX		PPIO_D18	SMC0_A05	TM0_AC12
PD_14	PPIO_D11	PWM2_TRIP0	MLB0_CLKOUT	SMC0_D06	
PD_15	PPIO_D10	PWM2_CH		SMC0_D05	

Table 24. Signal Multiplexing for Port E

Signal Name	Multiplexed Function 0	Multiplexed Function 1	Multiplexed Function 2	Multiplexed Function 3	Multiplexed Function Input Tap
PE_00	PPIO_D09	PWM2_CL		SMC0_D04	
PE_01	PPIO_FS2	SPIO_SEL5	UART1_CTS	C1_FLG0	
PE_02	PPIO_FS1	SPIO_SEL6	UART1_RTS	C2_FLG0	

ADSP-SC582/SC583/SC584/SC587/SC589/ADSP-21583/21584/21587

Table 24. Signal Multiplexing for Port E (Continued)

Signal Name	Multiplexed Function 0	Multiplexed Function 1	Multiplexed Function 2	Multiplexed Function 3	Multiplexed Function Input Tap
PE_03	PPIO_CLK	SPI0_SEL7	SPI2_SEL2	C1_FLG1	
PE_04	PPIO_D08	PWM2_DH	SPI2_SEL3	C2_FLG1	
PE_05	PPIO_D07	PWM2_SYNC	SPI2_SEL4	C1_FLG2	
PE_06	PPIO_D06		SPI2_SEL5	C2_FLG2	
PE_07	PPIO_D05		SPI1_SEL2	C1_FLG3	
PE_08	PPIO_D04	SPI1_SEL5	SPI1_RDY	C2_FLG3	
PE_09	PPIO_D03	PWM0_SYNC	TM0_TMR0	SMC0_D03	
PE_10	PPIO_D02	PWM2_DL	UART2_RTS	SMC0_D02	
PE_11	PPIO_D01	SPI1_SEL3	UART2_CTS	SMC0_D01	SPI1_SS
PE_12	PPIO_D00	SPI1_SEL4	SPI2_RDY	SMC0_D00	
PE_13	SPI1_CLK		PPIO_D20	SMC0_AMS1	
PE_14	SPI1_MISO		PPIO_D21	SMC0_ABE0	
PE_15	SPI1_MOSI		PPIO_D22	SMC0_ABE1	

Table 25. Signal Multiplexing for Port F

Signal Name	Multiplexed Function 0	Multiplexed Function 1	Multiplexed Function 2	Multiplexed Function 3	Multiplexed Function Input Tap
PF_00	TM0_TMR6	SPI1_SEL6			
PF_01	TM0_TMR7	SPI1_SEL7			
PF_02	MSIO_D0	HADC0_EOC_DOUT			
PF_03	MSIO_D1	HADC0_MUX2			
PF_04	MSIO_D2	HADC0_MUX1			
PF_05	MSIO_D3	HADC0_MUX0			
PF_06	MSIO_D4	PWM2_AL			
PF_07	MSIO_D5	PWM2_AH			
PF_08	MSIO_D6	PWM2_BL			
PF_09	MSIO_D7	PWM2_BH			
PF_10	MSIO_CMD				
PF_11	MSIO_CLK				
PF_12	MSIO_CD				
PF_13	ETH1_CRS	TRACE0_D08	TRACE0_D00	MSIO_INT	
PF_14	ETH1_MDC	TRACE0_D09	TRACE0_D01		
PF_15	ETH1_MDIO	TRACE0_D10	TRACE0_D02		

Table 26. Signal Multiplexing for Port G

Signal Name	Multiplexed Function 0	Multiplexed Function 1	Multiplexed Function 2	Multiplexed Function 3	Multiplexed Function Input Tap
PG_00	ETH1_REFCLK	TRACE0_CLK			
PG_01	ETH1_TXEN	TRACE0_D11	TRACE0_D03		
PG_02	ETH1_TXD0	TRACE0_D12	TRACE0_D04		
PG_03	ETH1_TXD1	TRACE0_D13	TRACE0_D05		
PG_04	ETH1_RXD0	TRACE0_D14	TRACE0_D06		
PG_05	ETH1_RXD1	TRACE0_D15	TRACE0_D07		

ADSP-SC582/SC583/SC584/SC587/SC589/ADSP-21583/21584/21587

ADSP-SC58X/ADSP-2158X DESIGNER QUICK REFERENCE

Table 27 provides a quick reference summary of pin related information for circuit board design. The columns in this table provide the following information:

- The Signal Name column includes the signal name for every pin and the GPIO multiplexed pin function, where applicable.
- The Type column identifies the I/O type or supply type of the pin. The abbreviations used in this column are a (analog), s (supply), g (ground) and Input, Output, and InOut.
- The Driver Type column identifies the driver type used by the corresponding pin. The driver types are defined in the [Output Drive Currents](#) section of this data sheet.
- The Internal Term column specifies the termination present when the processor is not in the reset state.
- The Reset Term column specifies the termination present when the processor is in the reset state.
- The Reset Drive column specifies the active drive on the signal when the processor is in the reset state.
- The Power Domain column specifies the power supply domain in which the signal resides.
- The Description and Notes column identifies any special requirements or characteristics for a signal. These recommendations apply whether or not the hardware block associated with the signal is featured on the product. If no special requirements are listed, the signal can be left unconnected if it is not used. For multiplexed general-purpose I/O pins, this column identifies the functions available on the pin.

Table 27. ADSP-SC58x/ADSP-2158x Designer Quick Reference

Signal Name	Type	Driver Type	Internal Term	Reset Term	Reset Drive	Power Domain	Description and Notes
DAI0_PIN01	InOut	A	PullDown	none	none	VDD_EXT	Desc: DAI0 Pin 1 Notes: No notes
DAI0_PIN02	InOut	A	PullDown	none	none	VDD_EXT	Desc: DAI0 Pin 2 Notes: No notes
DAI0_PIN03	InOut	A	PullDown	none	none	VDD_EXT	Desc: DAI0 Pin 3 Notes: No notes
DAI0_PIN04	InOut	A	PullDown	none	none	VDD_EXT	Desc: DAI0 Pin 4 Notes: No notes
DAI0_PIN05	InOut	A	PullDown	none	none	VDD_EXT	Desc: DAI0 Pin 5 Notes: No notes
DAI0_PIN06	InOut	A	PullDown	none	none	VDD_EXT	Desc: DAI0 Pin 6 Notes: No notes
DAI0_PIN07	InOut	A	PullDown	none	none	VDD_EXT	Desc: DAI0 Pin 7 Notes: No notes
DAI0_PIN08	InOut	A	PullDown	none	none	VDD_EXT	Desc: DAI0 Pin 8 Notes: No notes
DAI0_PIN09	InOut	A	PullDown	none	none	VDD_EXT	Desc: DAI0 Pin 9 Notes: No notes
DAI0_PIN10	InOut	A	PullDown	none	none	VDD_EXT	Desc: DAI0 Pin 10 Notes: No notes
DAI0_PIN11	InOut	A	PullDown	none	none	VDD_EXT	Desc: DAI0 Pin 11 Notes: No notes
DAI0_PIN12	InOut	A	PullDown	none	none	VDD_EXT	Desc: DAI0 Pin 12 Notes: No notes
DAI0_PIN13	InOut	A	PullDown	none	none	VDD_EXT	Desc: DAI0 Pin 13 Notes: No notes
DAI0_PIN14	InOut	A	PullDown	none	none	VDD_EXT	Desc: DAI0 Pin 14 Notes: No notes
DAI0_PIN15	InOut	A	PullDown	none	none	VDD_EXT	Desc: DAI0 Pin 15 Notes: No notes

ADSP-SC582/SC583/SC584/SC587/SC589/ADSP-21583/21584/21587

Table 27. ADSP-SC58x/ADSP-2158x Designer Quick Reference (Continued)

Signal Name	Type	Driver Type	Internal Term	Reset Term	Reset Drive	Power Domain	Description and Notes
DAI0_PIN16	InOut	A	PullDown	none	none	VDD_EXT	Desc: DAI0 Pin 16 Notes: No notes
DAI0_PIN17	InOut	A	PullDown	none	none	VDD_EXT	Desc: DAI0 Pin 17 Notes: No notes
DAI0_PIN18	InOut	A	PullDown	none	none	VDD_EXT	Desc: DAI0 Pin 18 Notes: No notes
DAI0_PIN19	InOut	A	PullDown	none	none	VDD_EXT	Desc: DAI0 Pin 19 Notes: No notes
DAI0_PIN20	InOut	A	PullDown	none	none	VDD_EXT	Desc: DAI0 Pin 20 Notes: No notes
DAI1_PIN01	InOut	A	PullDown	none	none	VDD_EXT	Desc: DAI1 Pin 1 Notes: No notes
DAI1_PIN02	InOut	A	PullDown	none	none	VDD_EXT	Desc: DAI1 Pin 2 Notes: No notes
DAI1_PIN03	InOut	A	PullDown	none	none	VDD_EXT	Desc: DAI1 Pin 3 Notes: No notes
DAI1_PIN04	InOut	A	PullDown	none	none	VDD_EXT	Desc: DAI1 Pin 4 Notes: No notes
DAI1_PIN05	InOut	A	PullDown	none	none	VDD_EXT	Desc: DAI1 Pin 5 Notes: No notes
DAI1_PIN06	InOut	A	PullDown	none	none	VDD_EXT	Desc: DAI1 Pin 6 Notes: No notes
DAI1_PIN07	InOut	A	PullDown	none	none	VDD_EXT	Desc: DAI1 Pin 7 Notes: No notes
DAI1_PIN08	InOut	A	PullDown	none	none	VDD_EXT	Desc: DAI1 Pin 8 Notes: No notes
DAI1_PIN09	InOut	A	PullDown	none	none	VDD_EXT	Desc: DAI1 Pin 9 Notes: No notes
DAI1_PIN10	InOut	A	PullDown	none	none	VDD_EXT	Desc: DAI1 Pin 10 Notes: No notes
DAI1_PIN11	InOut	A	PullDown	none	none	VDD_EXT	Desc: DAI1 Pin 11 Notes: No notes
DAI1_PIN12	InOut	A	PullDown	none	none	VDD_EXT	Desc: DAI1 Pin 12 Notes: No notes
DAI1_PIN13	InOut	A	PullDown	none	none	VDD_EXT	Desc: DAI1 Pin 13 Notes: No notes
DAI1_PIN14	InOut	A	PullDown	none	none	VDD_EXT	Desc: DAI1 Pin 14 Notes: No notes
DAI1_PIN15	InOut	A	PullDown	none	none	VDD_EXT	Desc: DAI1 Pin 15 Notes: No notes
DAI1_PIN16	InOut	A	PullDown	none	none	VDD_EXT	Desc: DAI1 Pin 16 Notes: No notes
DAI1_PIN17	InOut	A	PullDown	none	none	VDD_EXT	Desc: DAI1 Pin 17 Notes: No notes
DAI1_PIN18	InOut	A	PullDown	none	none	VDD_EXT	Desc: DAI1 Pin 18 Notes: No notes
DAI1_PIN19	InOut	A	PullDown	none	none	VDD_EXT	Desc: DAI1 Pin 19 Notes: No notes

ADSP-SC582/SC583/SC584/SC587/SC589/ADSP-21583/21584/21587

Table 27. ADSP-SC58x/ADSP-2158x Designer Quick Reference (Continued)

Signal Name	Type	Driver Type	Internal Term	Reset Term	Reset Drive	Power Domain	Description and Notes
DAI1_PIN20	InOut	A	PullDown	none	none	VDD_EXT	Desc: DAI1 Pin 20 Notes: No notes
DMC0_A00	Output	B	none	none	none	VDD_DMC	Desc: DMC0 Address 0 Notes: No notes
DMC0_A01	Output	B	none	none	none	VDD_DMC	Desc: DMC0 Address 1 Notes: No notes
DMC0_A02	Output	B	none	none	none	VDD_DMC	Desc: DMC0 Address 2 Notes: No notes
DMC0_A03	Output	B	none	none	none	VDD_DMC	Desc: DMC0 Address 3 Notes: No notes
DMC0_A04	Output	B	none	none	none	VDD_DMC	Desc: DMC0 Address 4 Notes: No notes
DMC0_A05	Output	B	none	none	none	VDD_DMC	Desc: DMC0 Address 5 Notes: No notes
DMC0_A06	Output	B	none	none	none	VDD_DMC	Desc: DMC0 Address 6 Notes: No notes
DMC0_A07	Output	B	none	none	none	VDD_DMC	Desc: DMC0 Address 7 Notes: No notes
DMC0_A08	Output	B	none	none	none	VDD_DMC	Desc: DMC0 Address 8 Notes: No notes
DMC0_A09	Output	B	none	none	none	VDD_DMC	Desc: DMC0 Address 9 Notes: No notes
DMC0_A10	Output	B	none	none	none	VDD_DMC	Desc: DMC0 Address 10 Notes: No notes
DMC0_A11	Output	B	none	none	none	VDD_DMC	Desc: DMC0 Address 11 Notes: No notes
DMC0_A12	Output	B	none	none	none	VDD_DMC	Desc: DMC0 Address 12 Notes: No notes
DMC0_A13	Output	B	none	none	none	VDD_DMC	Desc: DMC0 Address 13 Notes: No notes
DMC0_A14	Output	B	none	none	none	VDD_DMC	Desc: DMC0 Address 14 Notes: No notes
DMC0_A15	Output	B	none	none	none	VDD_DMC	Desc: DMC0 Address 15 Notes: No notes
DMC0_BA0	Output	B	none	none	none	VDD_DMC	Desc: DMC0 Bank Address Input 0 Notes: No notes
DMC0_BA1	Output	B	none	none	none	VDD_DMC	Desc: DMC0 Bank Address Input 1 Notes: No notes
DMC0_BA2	Output	B	none	none	none	VDD_DMC	Desc: DMC0 Bank Address Input 2 Notes: No notes
$\overline{\text{DMC0_CAS}}$	Output	B	none	none	none	VDD_DMC	Desc: DMC0 Column Address Strobe Notes: No notes
DMC0_CK	Output	C	none	none	L	VDD_DMC	Desc: DMC0 Clock Notes: No notes
DMC0_CKE	Output	B	none	none	L	VDD_DMC	Desc: DMC0 Clock Enable Notes: No notes
$\overline{\text{DMC0_CK}}$	Output	C	none	none	L	VDD_DMC	Desc: DMC0 Clock (Complement) Notes: No notes

ADSP-SC582/SC583/SC584/SC587/SC589/ADSP-21583/21584/21587

Table 27. ADSP-SC58x/ADSP-2158x Designer Quick Reference (Continued)

Signal Name	Type	Driver Type	Internal Term	Reset Term	Reset Drive	Power Domain	Description and Notes
DMC0_CS0	Output	B	none	none	none	VDD_DMC	Desc: DMC0 Chip Select 0 Notes: No notes
DMC0_DQ00	InOut	B	Internal logic ensures that input signal does not float	none	none	VDD_DMC	Desc: DMC0 Data 0 Notes: No notes
DMC0_DQ01	InOut	B	Internal logic ensures that input signal does not float	none	none	VDD_DMC	Desc: DMC0 Data 1 Notes: No notes
DMC0_DQ02	InOut	B	Internal logic ensures that input signal does not float	none	none	VDD_DMC	Desc: DMC0 Data 2 Notes: No notes
DMC0_DQ03	InOut	B	Internal logic ensures that input signal does not float	none	none	VDD_DMC	Desc: DMC0 Data 3 Notes: No notes
DMC0_DQ04	InOut	B	Internal logic ensures that input signal does not float	none	none	VDD_DMC	Desc: DMC0 Data 4 Notes: No notes
DMC0_DQ05	InOut	B	Internal logic ensures that input signal does not float	none	none	VDD_DMC	Desc: DMC0 Data 5 Notes: No notes
DMC0_DQ06	InOut	B	Internal logic ensures that input signal does not float	none	none	VDD_DMC	Desc: DMC0 Data 6 Notes: No notes
DMC0_DQ07	InOut	B	Internal logic ensures that input signal does not float	none	none	VDD_DMC	Desc: DMC0 Data 7 Notes: No notes
DMC0_DQ08	InOut	B	Internal logic ensures that input signal does not float	none	none	VDD_DMC	Desc: DMC0 Data 8 Notes: No notes
DMC0_DQ09	InOut	B	Internal logic ensures that input signal does not float	none	none	VDD_DMC	Desc: DMC0 Data 9 Notes: No notes
DMC0_DQ10	InOut	B	Internal logic ensures that input signal does not float	none	none	VDD_DMC	Desc: DMC0 Data 10 Notes: No notes
DMC0_DQ11	InOut	B	Internal logic ensures that input signal does not float	none	none	VDD_DMC	Desc: DMC0 Data 11 Notes: No notes

ADSP-SC582/SC583/SC584/SC587/SC589/ADSP-21583/21584/21587

Table 27. ADSP-SC58x/ADSP-2158x Designer Quick Reference (Continued)

Signal Name	Type	Driver Type	Internal Term	Reset Term	Reset Drive	Power Domain	Description and Notes
DMC0_DQ12	InOut	B	Internal logic ensures that input signal does not float	none	none	VDD_DMC	Desc: DMC0 Data 12 Notes: No notes
DMC0_DQ13	InOut	B	Internal logic ensures that input signal does not float	none	none	VDD_DMC	Desc: DMC0 Data 13 Notes: No notes
DMC0_DQ14	InOut	B	Internal logic ensures that input signal does not float	none	none	VDD_DMC	Desc: DMC0 Data 14 Notes: No notes
DMC0_DQ15	InOut	B	Internal logic ensures that input signal does not float	none	none	VDD_DMC	Desc: DMC0 Data 15 Notes: No notes
DMC0_LDM	Output	B	none	none	none	VDD_DMC	Desc: DMC0 Data Mask for Lower Byte Notes: No notes
$\overline{\text{DMC0_LDQS}}$	InOut	C	Internal logic ensures that input signal does not float	none	none	VDD_DMC	Desc: DMC0 Data Strobe for Lower Byte (Complement) Notes: No notes
DMC0_LDQS	InOut	C	Internal logic ensures that input signal does not float	none	none	VDD_DMC	Desc: DMC0 Data Strobe for Lower Byte Notes: External weak pull-down required in LPDDR mode
DMC0_ODT	Output	B	none	none	none	VDD_DMC	Desc: DMC0 On-Die Termination Notes: No notes
$\overline{\text{DMC0_RAS}}$	Output	B	none	none	none	VDD_DMC	Desc: DMC0 Row Address Strobe Notes: No notes
$\overline{\text{DMC0_RESET}}$	Output	B	none	none	none	VDD_DMC	Desc: DMC0 Reset (DDR3 Only) Notes: No notes
DMC0_RZQ	a	B	none	none	none	VDD_DMC	Desc: DMC0 External Calibration Resistor Connection Notes: Applicable for DDR2 and DDR3 only. External pull-down of 34 Ω need to be added.
DMC0_UDM	Output	B	none	none	none	VDD_DMC	Desc: DMC0 Data Mask for Upper Byte Notes: No notes
DMC0_UDQS	InOut	C	Internal logic ensures that input signal does not float	none	none	VDD_DMC	Desc: DMC0 Data Strobe for Upper Byte Notes: External weak pull-down required in LPDDR mode
$\overline{\text{DMC0_UDQS}}$	InOut	C	Internal logic ensures that input signal does not float	none	none	VDD_DMC	Desc: DMC0 Data Strobe for Upper Byte (Complement) Notes: No notes
DMC0_VREF	a		none	none	none	VDD_DMC	Desc: DMC0 Voltage Reference Notes: No notes

ADSP-SC582/SC583/SC584/SC587/SC589/ADSP-21583/21584/21587

Table 27. ADSP-SC58x/ADSP-2158x Designer Quick Reference (Continued)

Signal Name	Type	Driver Type	Internal Term	Reset Term	Reset Drive	Power Domain	Description and Notes
$\overline{\text{DMC0_WE}}$	Output	B	none	none	none	VDD_DMC	Desc: DMC0 Write Enable Notes: No notes
DMC1_A00	Output	B	none	none	none	VDD_DMC	Desc: DMC1 Address 0 Notes: No notes
DMC1_A01	Output	B	none	none	none	VDD_DMC	Desc: DMC1 Address 1 Notes: No notes
DMC1_A02	Output	B	none	none	none	VDD_DMC	Desc: DMC1 Address 2 Notes: No notes
DMC1_A03	Output	B	none	none	none	VDD_DMC	Desc: DMC1 Address 3 Notes: No notes
DMC1_A04	Output	B	none	none	none	VDD_DMC	Desc: DMC1 Address 4 Notes: No notes
DMC1_A05	Output	B	none	none	none	VDD_DMC	Desc: DMC1 Address 5 Notes: No notes
DMC1_A06	Output	B	none	none	none	VDD_DMC	Desc: DMC1 Address 6 Notes: No notes
DMC1_A07	Output	B	none	none	none	VDD_DMC	Desc: DMC1 Address 7 Notes: No notes
DMC1_A08	Output	B	none	none	none	VDD_DMC	Desc: DMC1 Address 8 Notes: No notes
DMC1_A09	Output	B	none	none	none	VDD_DMC	Desc: DMC1 Address 9 Notes: No notes
DMC1_A10	Output	B	none	none	none	VDD_DMC	Desc: DMC1 Address 10 Notes: No notes
DMC1_A11	Output	B	none	none	none	VDD_DMC	Desc: DMC1 Address 11 Notes: No notes
DMC1_A12	Output	B	none	none	none	VDD_DMC	Desc: DMC1 Address 12 Notes: No notes
DMC1_A13	Output	B	none	none	none	VDD_DMC	Desc: DMC1 Address 13 Notes: No notes
DMC1_A14	Output	B	none	none	none	VDD_DMC	Desc: DMC1 Address 14 Notes: No notes
DMC1_A15	Output	B	none	none	none	VDD_DMC	Desc: DMC1 Address 15 Notes: No notes
DMC1_BA0	Output	B	none	none	none	VDD_DMC	Desc: DMC1 Bank Address Input 0 Notes: No notes
DMC1_BA1	Output	B	none	none	none	VDD_DMC	Desc: DMC1 Bank Address Input 1 Notes: No notes
DMC1_BA2	Output	B	none	none	none	VDD_DMC	Desc: DMC1 Bank Address Input 2 Notes: No notes
$\overline{\text{DMC1_CAS}}$	Output	B	none	none	none	VDD_DMC	Desc: DMC1 Column Address Strobe Notes: No notes
DMC1_CK	Output	C	none	none	L	VDD_DMC	Desc: DMC1 Clock Notes: No notes
DMC1_CKE	Output	B	none	none	L	VDD_DMC	Desc: DMC1 Clock Enable Notes: No notes
$\overline{\text{DMC1_CK}}$	Output	C	none	none	L	VDD_DMC	Desc: DMC1 Clock (Complement) Notes: No notes

ADSP-SC582/SC583/SC584/SC587/SC589/ADSP-21583/21584/21587

Table 27. ADSP-SC58x/ADSP-2158x Designer Quick Reference (Continued)

Signal Name	Type	Driver Type	Internal Term	Reset Term	Reset Drive	Power Domain	Description and Notes
DMC1_CS0	Output	B	none	none	none	VDD_DMC	Desc: DMC1 Chip Select 0 Notes: No notes
DMC1_DQ00	InOut	B	Internal logic ensures that input signal does not float	none	none	VDD_DMC	Desc: DMC1 Data 0 Notes: No notes
DMC1_DQ01	InOut	B	Internal logic ensures that input signal does not float	none	none	VDD_DMC	Desc: DMC1 Data 1 Notes: No notes
DMC1_DQ02	InOut	B	Internal logic ensures that input signal does not float	none	none	VDD_DMC	Desc: DMC1 Data 2 Notes: No notes
DMC1_DQ03	InOut	B	Internal logic ensures that input signal does not float	none	none	VDD_DMC	Desc: DMC1 Data 3 Notes: No notes
DMC1_DQ04	InOut	B	Internal logic ensures that input signal does not float	none	none	VDD_DMC	Desc: DMC1 Data 4 Notes: No notes
DMC1_DQ05	InOut	B	Internal logic ensures that input signal does not float	none	none	VDD_DMC	Desc: DMC1 Data 5 Notes: No notes
DMC1_DQ06	InOut	B	Internal logic ensures that input signal does not float	none	none	VDD_DMC	Desc: DMC1 Data 6 Notes: No notes
DMC1_DQ07	InOut	B	Internal logic ensures that input signal does not float	none	none	VDD_DMC	Desc: DMC1 Data 7 Notes: No notes
DMC1_DQ08	InOut	B	Internal logic ensures that input signal does not float	none	none	VDD_DMC	Desc: DMC1 Data 8 Notes: No notes
DMC1_DQ09	InOut	B	Internal logic ensures that input signal does not float	none	none	VDD_DMC	Desc: DMC1 Data 9 Notes: No notes
DMC1_DQ10	InOut	B	Internal logic ensures that input signal does not float	none	none	VDD_DMC	Desc: DMC1 Data 10 Notes: No notes
DMC1_DQ11	InOut	B	Internal logic ensures that input signal does not float	none	none	VDD_DMC	Desc: DMC1 Data 11 Notes: No notes

ADSP-SC582/SC583/SC584/SC587/SC589/ADSP-21583/21584/21587

Table 27. ADSP-SC58x/ADSP-2158x Designer Quick Reference (Continued)

Signal Name	Type	Driver Type	Internal Term	Reset Term	Reset Drive	Power Domain	Description and Notes
DMC1_DQ12	InOut	B	Internal logic ensures that input signal does not float	none	none	VDD_DMC	Desc: DMC1 Data 12 Notes: No notes
DMC1_DQ13	InOut	B	Internal logic ensures that input signal does not float	none	none	VDD_DMC	Desc: DMC1 Data 13 Notes: No notes
DMC1_DQ14	InOut	B	Internal logic ensures that input signal does not float	none	none	VDD_DMC	Desc: DMC1 Data 14 Notes: No notes
DMC1_DQ15	InOut	B	Internal logic ensures that input signal does not float	none	none	VDD_DMC	Desc: DMC1 Data 15 Notes: No notes
DMC1_LDM	Output	B	none	none	none	VDD_DMC	Desc: DMC1 Data Mask for Lower Byte Notes: No notes
DMC1_LDQS	InOut	C	Internal logic ensures that input signal does not float	none	none	VDD_DMC	Desc: DMC1 Data Strobe for Lower Byte Notes: External weak pull-down required in LPDDR mode
$\overline{\text{DMC1_LDQS}}$	InOut	C	Internal logic ensures that input signal does not float	none	none	VDD_DMC	Desc: DMC1 Data Strobe for Lower Byte (Complement) Notes: No notes
DMC1_ODT	Output	B	none	none	none	VDD_DMC	Desc: DMC1 On-Die Termination Notes: No notes
$\overline{\text{DMC1_RAS}}$	Output	B	none	none	none	VDD_DMC	Desc: DMC1 Row Address Strobe Notes: No notes
$\overline{\text{DMC1_RESET}}$	InOut	B	none	none	none	VDD_DMC	Desc: DMC1 Reset (DDR3 Only) Notes: No notes
DMC1_RZQ	a	B	none	none	none	VDD_DMC	Desc: DMC1 External Calibration Resistor Connection Notes: Applicable for DDR2 and DDR3 only. External pull-down of 34 Ω need to be added.
DMC1_UDM	Output	B	none	none	none	VDD_DMC	Desc: DMC1 Data Mask for Upper Byte Notes: No notes
DMC1_UDQS	InOut	C	Internal logic ensures that input signal does not float	none	none	VDD_DMC	Desc: DMC1 Data Strobe for Upper Byte Notes: External weak pull-down required in LPDDR mode
$\overline{\text{DMC1_UDQS}}$	InOut	C	Internal logic ensures that input signal does not float	none	none	VDD_DMC	Desc: DMC1 Data Strobe for Upper Byte (Complement) Notes: No notes
DMC1_VREF	a		none	none	none	VDD_DMC	Desc: DMC1 Voltage Reference Notes: No notes

ADSP-SC582/SC583/SC584/SC587/SC589/ADSP-21583/21584/21587

Table 27. ADSP-SC58x/ADSP-2158x Designer Quick Reference (Continued)

Signal Name	Type	Driver Type	Internal Term	Reset Term	Reset Drive	Power Domain	Description and Notes
DMC1_WE	Output	B	none	none	none		Desc: DMC1 Write Enable Notes: No notes
GND	g	NA	none	none	none		Desc: Ground Notes: No notes
HADC0_VIN0	a	NA	none	none	none	VDD_HADC	Desc: HADC0 Analog Input at Channel 0 Notes: If Input not used connect to GND
HADC0_VIN1	a	NA	none	none	none	VDD_HADC	Desc: HADC0 Analog Input at Channel 1 Notes: If Input not used connect to GND
HADC0_VIN2	a	NA	none	none	none	VDD_HADC	Desc: HADC0 Analog Input at Channel 2 Notes: If Input not used connect to GND
HADC0_VIN3	a	NA	none	none	none	VDD_HADC	Desc: HADC0 Analog Input at Channel 3 Notes: If Input not used connect to GND
HADC0_VIN4	a	NA	none	none	none	VDD_HADC	Desc: HADC0 Analog Input at Channel 4 Notes: If Input not used connect to GND
HADC0_VIN5	a	NA	none	none	none	VDD_HADC	Desc: HADC0 Analog Input at Channel 5 Notes: If Input not used connect to GND
HADC0_VIN6	a	NA	none	none	none	VDD_HADC	Desc: HADC0 Analog Input at Channel 6 Notes: If Input not used connect to GND
HADC0_VIN7	a	NA	none	none	none	VDD_HADC	Desc: HADC0 Analog Input at Channel 7 Notes: If Input not used connect to GND
HADC0_VREFN	s	NA	none	none	none	VDD_HADC	Desc: HADC0 Ground Reference for ADC Notes: Can be left floating if HADC and TMU are not used
HADC0_VREFP	s	NA	none	none	none	VDD_HADC	Desc: HADC0 External Reference for ADC Notes: Can be left floating if HADC and TMU are not used
JTG_TCK	Input		PullUp	none	none	VDD_EXT	Desc: JTAG Clock Notes: No notes
JTG_TDI	Input		PullUp	none	none	VDD_EXT	Desc: JTAG Serial Data In Notes: No notes
JTG_TDO	Output	A	none	none	none	VDD_EXT	Desc: JTAG Serial Data Out Notes: No notes

ADSP-SC582/SC583/SC584/SC587/SC589/ADSP-21583/21584/21587

Table 27. ADSP-SC58x/ADSP-2158x Designer Quick Reference (Continued)

Signal Name	Type	Driver Type	Internal Term	Reset Term	Reset Drive	Power Domain	Description and Notes
JTG_TMS	InOut	A	PullUp	none	none	VDD_EXT	Desc: JTAG Mode Select Notes: No notes
$\overline{\text{JTG_TRST}}$	Input		PullDown	none	none	VDD_EXT	Desc: JTAG Reset Notes: No notes
MLB0_CLKN	Input	NA	Internal logic ensures that input signal does not float	none	none	VDD_EXT	Desc: MLB0 Differential Clock (-) Notes: No notes
MLB0_CLKP	Input	NA	Internal logic ensures that input signal does not float	none	none	VDD_EXT	Desc: MLB0 Differential Clock (+) Notes: No notes
MLB0_DATN	InOut	I	Internal logic ensures that input signal does not float	none	none	VDD_EXT	Desc: MLB0 Differential Data (-) Notes: No notes
MLB0_DATP	InOut	I	Internal logic ensures that input signal does not float	none	none	VDD_EXT	Desc: MLB0 Differential Data (+) Notes: No notes
MLB0_SIGN	InOut	I	Internal logic ensures that input signal does not float	none	none	VDD_EXT	Desc: MLB0 Differential Signal (-) Notes: No notes
MLB0_SIGP	InOut	I	Internal logic ensures that input signal does not float	none	none	VDD_EXT	Desc: MLB0 Differential Signal (+) Notes: No notes
PA_00	InOut	A	PullDown	none	none	VDD_EXT	Desc: PORTA Position 0 EMAC0 Transmit Data 0 SMC0 Address 21 Notes: No notes
PA_01	InOut	A	PullDown	none	none	VDD_EXT	Desc: PORTA Position 1 EMAC0 Transmit Data 1 SMC0 Address 20 Notes: No notes
PA_02	InOut	A	PullDown	none	none	VDD_EXT	Desc: PORTA Position 2 EMAC0 Management Channel Clock SMC0 Address 24 Notes: No notes
PA_03	InOut	A	PullDown	none	none	VDD_EXT	Desc: PORTA Position 3 EMAC0 Management Channel Serial Data SMC0 Address 23 Notes: No notes
PA_04	InOut	A	PullDown	none	none	VDD_EXT	Desc: PORTA Position 4 EMAC0 Receive Data 0 SMC0 Address 19 Notes: No notes
PA_05	InOut	A	PullDown	none	none	VDD_EXT	Desc: PORTA Position 5 EMAC0 Receive Data 1 SMC0 Address 18 Notes: No notes

ADSP-SC582/SC583/SC584/SC587/SC589/ADSP-21583/21584/21587

Table 27. ADSP-SC58x/ADSP-2158x Designer Quick Reference (Continued)

Signal Name	Type	Driver Type	Internal Term	Reset Term	Reset Drive	Power Domain	Description and Notes
PA_06	InOut	A	PullDown	none	none	VDD_EXT	Desc: PORTA Position 6 EMAC0 RXCLK (10/100/1000) or REFCLK (10/100) SMC0 Address 17 Notes: No notes
PA_07	InOut	A	PullDown	none	none	VDD_EXT	Desc: EMAC0 RXCTL (10/100/1000) or CRS (10/100) PORTA Position 7 EMAC0 Carrier Sense/RMII Receive Data Valid SMC0 Address 16 Notes: No notes
PA_08	InOut	A	PullDown	none	none	VDD_EXT	Desc: PORTA Position 8 EMAC0 Receive Data 2 SMC0 Address 12 Notes: No notes
PA_09	InOut	A	PullDown	none	none	VDD_EXT	Desc: PORTA Position 9 EMAC0 Receive Data 3 SMC0 Address 11 Notes: No notes
PA_10	InOut	A	PullDown	none	none	VDD_EXT	Desc: EMAC0 TXCTL (10/100/1000) or TXEN (10/100) PORTA Position 10 EMAC0 Transmit Enable SMC0 Address 22 Notes: No notes
PA_11	InOut	A	PullDown	none	none	VDD_EXT	Desc: PORTA Position 11 EMAC0 Transmit Clock SMC0 Address 15 Notes: No notes
PA_12	InOut	A	PullDown	none	none	VDD_EXT	Desc: PORTA Position 12 EMAC0 Transmit Data 2 SMC0 Address 14 Notes: No notes
PA_13	InOut	A	PullDown	none	none	VDD_EXT	Desc: PORTA Position 13 EMAC0 Transmit Data 3 SMC0 Address 13 Notes: No notes
PA_14	InOut	A	PullDown	none	none	VDD_EXT	Desc: PORTA Position 14 EMAC0 PTP Pulse-Per-Second Output 3 SINC0 Data 0 SMC0 Address 10 Notes: No notes
PA_15	InOut	A	PullDown	none	none	VDD_EXT	Desc: PORTA Position 15 EMAC0 PTP Pulse-Per-Second Output 2 SINC0 Data 1 SMC0 Address 9 Notes: No notes
PB_00	InOut	A	PullDown	none	none	VDD_EXT	Desc: PORTB Position 0 EMAC0 PTP Pulse-Per-Second Output 1 EPPIO Data 14 SINC0 Data 2 SMC0 Address 8 TIMER0 Alternate Clock 3 Notes: No notes
PB_01	InOut	A	PullDown	none	none	VDD_EXT	Desc: PORTB Position 1 EMAC0 PTP Pulse-Per-Second Output 0 EPPIO Data 15 SINC0 Clock 0 SMC0 Address 7 TIMER0 Alternate Clock 4 Notes: No notes
PB_02	InOut	A	PullDown	none	none	VDD_EXT	Desc: PORTB Position 2 EMAC0 PTP Clock Input 0 EPPIO Data 16 SMC0 Address 4 UART1 Transmit Notes: No notes

ADSP-SC582/SC583/SC584/SC587/SC589/ADSP-21583/21584/21587

Table 27. ADSP-SC58x/ADSP-2158x Designer Quick Reference (Continued)

Signal Name	Type	Driver Type	Internal Term	Reset Term	Reset Drive	Power Domain	Description and Notes
PB_03	InOut	A	PullDown	none	none	VDD_EXT	Desc: PORTB Position 3 EMAC0 PTP Auxiliary Trigger Input 0 EPPIO Data 17 SMC0 Address 3 UART1 Receive TIMER0 Alternate Capture Input 1 Notes: No notes
PB_04	InOut	A	PullDown	none	none	VDD_EXT	Desc: PORTB Position 4 EPPIO Data 12 MLB0 Single-Ended Clock SINC0 Data 3 SMC0 Asynchronous Ready EMAC0 PTP Auxiliary Trigger Input 1 Notes: No notes
PB_05	InOut	A	PullDown	none	none	VDD_EXT	Desc: PORTB Position 5 EPPIO Data 13 MLB0 Single-Ended Signal SMC0 Address 1 EMAC0 PTP Auxiliary Trigger Input 2 Notes: No notes
PB_06	InOut	A	PullDown	none	none	VDD_EXT	Desc: PORTB Position 6 MLB0 Single-Ended Data PWM0 Channel B High Side SMC0 Address 2 EMAC0 PTP Auxiliary Trigger Input 3 Notes: No notes
PB_07	InOut	A	PullDown	none	none	VDD_EXT	Desc: PORTB Position 7 LP1 Data 0 PWM0 Channel A High Side SMC0 Data 15 TIMER0 Timer 3 Notes: No notes
PB_08	InOut	A	PullDown	none	none	VDD_EXT	Desc: PORTB Position 8 LP1 Data 1 PWM0 Channel A Low Side SMC0 Data 14 TIMER0 Timer 4 Notes: No notes
PB_09	InOut	A	PullDown	none	none	VDD_EXT	Desc: PORTB Position 9 CAN1 Transmit LP1 Data 2 SMC0 Data 13 Notes: No notes
PB_10	InOut	A	PullDown	none	none	VDD_EXT	Desc: PORTB Position 10 CAN1 Receive LP1 Data 3 SMC0 Data 12 TIMER0 Timer 2 TIMER0 Alternate Capture Input 4 Notes: No notes
PB_11	InOut	A	PullDown	none	none	VDD_EXT	Desc: PORTB Position 11 LP1 Data 4 PWM0 Channel D High Side SMC0 Data 11 CNT0 Count Zero Marker Notes: No notes
PB_12	InOut	A	PullDown	none	none	VDD_EXT	Desc: PORTB Position 12 LP1 Data 5 PWM0 Channel D Low Side SMC0 Data 10 CNT0 Count Up and Direction Notes: No notes
PB_13	InOut	A	PullDown	none	none	VDD_EXT	Desc: PORTB Position 13 LP1 Data 6 PWM0 Channel C High Side SMC0 Data 9 Notes: No notes

ADSP-SC582/SC583/SC584/SC587/SC589/ADSP-21583/21584/21587

Table 27. ADSP-SC58x/ADSP-2158x Designer Quick Reference (Continued)

Signal Name	Type	Driver Type	Internal Term	Reset Term	Reset Drive	Power Domain	Description and Notes
PB_14	InOut	A	PullDown	none	none	VDD_EXT	Desc: PORTB Position 14 LP1 Data 7 PWM0 Channel C Low Side SMC0 Data 8 TIMERO Timer 5 CNT0 Count Down and Gate Notes: No notes
PB_15	InOut	A	PullDown	none	none	VDD_EXT	Desc: PORTB Position 15 LP1 Acknowledge PWM0 Shutdown Input 0 SMC0 Write Enable TIMERO Timer 1 Notes: No notes
PCIE0_CLKM	Input	NA	PullDown	none	none	VDD_PCIE	Desc: PCIE0 CLK – Notes: No notes
PCIE0_CLKP	Input	NA	PullDown	none	none	VDD_PCIE	Desc: PCIE0 CLK + Notes: No notes
PCIE0_REF	a	NA	PullDown	none	none	VDD_PCIE	Desc: PCIE0 Reference Notes: No notes
PCIE0_RXM	Input	NA	PullDown	none	none	VDD_PCIE_RX	Desc: PCIE0 RX – Notes: No notes
PCIE0_RXP	Input	NA	PullDown	none	none	VDD_PCIE_RX	Desc: PCIE0 RX + Notes: No notes
PCIE0_TXM	InOut	J	PullDown	none	none	VDD_PCIE_TX	Desc: PCIE0 TX – Notes: No notes
PCIE0_TXP	InOut	J	PullDown	none	none	VDD_PCIE_TX	Desc: PCIE0 TX + Notes: No notes
PC_00	InOut	H	PullDown	none	none	VDD_EXT	Desc: PORTC Position 0 LP1 Clock PWM0 Channel B Low Side SMC0 Read Enable SPI0 Slave Select Output 4 Notes: No notes
PC_01	InOut	A	PullDown	none	none	VDD_EXT	Desc: PORTC Position 1 SPI2 Clock Notes: No notes
PC_02	InOut	A	PullDown	none	none	VDD_EXT	Desc: PORTC Position 2 SPI2 Master In, Slave Out Notes: No notes
PC_03	InOut	A	PullDown	none	none	VDD_EXT	Desc: PORTC Position 3 SPI2 Master Out, Slave In Notes: No notes
PC_04	InOut	A	PullDown	none	none	VDD_EXT	Desc: PORTC Position 4 SPI2 Data 2 Notes: No notes
PC_05	InOut	A	PullDown	none	none	VDD_EXT	Desc: PORTC Position 5 SPI2 Data 3 Notes: No notes
PC_06	InOut	A	PullDown	none	none	VDD_EXT	Desc: PORTC Position 6 SPI2 Slave Select Output 1 SPI2 Slave Select Input Notes: No notes
PC_07	InOut	A	PullDown	none	none	VDD_EXT	Desc: PORTC Position 7 CAN0 Receive SMC0 Memory Select 2 SPI0 Slave Select Output 1 TIMERO Alternate Capture Input 3 Notes: No notes

ADSP-SC582/SC583/SC584/SC587/SC589/ADSP-21583/21584/21587

Table 27. ADSP-SC58x/ADSP-2158x Designer Quick Reference (Continued)

Signal Name	Type	Driver Type	Internal Term	Reset Term	Reset Drive	Power Domain	Description and Notes
PC_08	InOut	A	PullDown	none	none	VDD_EXT	Desc: PORTC Position 8 CAN0 Transmit SMC0 Memory Select 3 Notes: No notes
PC_09	InOut	A	PullDown	none	none	VDD_EXT	Desc: PORTC Position 9 SPI0 Clock Notes: No notes
PC_10	InOut	A	PullDown	none	none	VDD_EXT	Desc: PORTC Position 10 SPI0 Master In, Slave Out Notes: No notes
PC_11	InOut	A	PullDown	none	none	VDD_EXT	Desc: PORTC Position 11 SPI0 Master Out, Slave In TIMER0 Clock Notes: No notes
PC_12	InOut	A	PullDown	none	none	VDD_EXT	Desc: PORTC Position 12 ACM0 External Trigger n SMC0 Address 25 SPI0 Ready SPI0 Slave Select Output 3 Notes: No notes
PC_13	InOut	A	PullDown	none	none	VDD_EXT	Desc: PORTC Position 13 ACM0 ADC Control Signals SPI1 Slave Select Output 1 UART0 Transmit Notes: No notes
PC_14	InOut	A	PullDown	none	none	VDD_EXT	Desc: PORTC Position 14 ACM0 ADC Control Signals UART0 Receive TIMER0 Alternate Capture Input 0 Notes: No notes
PC_15	InOut	A	PullDown	none	none	VDD_EXT	Desc: PORTC Position 15 ACM0 ADC Control Signals EPPI0 Frame Sync 3 (FIELD) SMC0 Memory Select 0 UART0 Request to Send Notes: No notes
PD_00	InOut	A	PullDown	none	none	VDD_EXT	Desc: PORTD Position 0 ACM0 ADC Control Signals EPPI0 Data 23 SMC0 Data 7 UART0 Clear to Send Notes: No notes
PD_01	InOut	A	PullDown	none	none	VDD_EXT	Desc: PORTD Position 1 ACM0 ADC Control Signals SMC0 Output Enable SPI0 Slave Select Output 2 SPI0 Slave Select Input Notes: No notes
PD_02	InOut	A	PullDown	none	none	VDD_EXT	Desc: PORTD Position 2 LP0 Data 0 PWM1 Shutdown Input 0 TRACE0 Trace Data 0 Notes: No notes
PD_03	InOut	A	PullDown	none	none	VDD_EXT	Desc: PORTD Position 3 LP0 Data 1 PWM1 Channel A High Side TRACE0 Trace Data 1 Notes: No notes
PD_04	InOut	A	PullDown	none	none	VDD_EXT	Desc: PORTD Position 4 LP0 Data 2 PWM1 Channel A Low Side TRACE0 Trace Data 2 Notes: No notes

ADSP-SC582/SC583/SC584/SC587/SC589/ADSP-21583/21584/21587

Table 27. ADSP-SC58x/ADSP-2158x Designer Quick Reference (Continued)

Signal Name	Type	Driver Type	Internal Term	Reset Term	Reset Drive	Power Domain	Description and Notes
PD_05	InOut	A	PullDown	none	none	VDD_EXT	Desc: PORTD Position 5 LP0 Data 3 PWM1 Channel B High Side TRACE0 Trace Data 3 Notes: No notes
PD_06	InOut	A	PullDown	none	none	VDD_EXT	Desc: PORTD Position 6 LP0 Data 4 PWM1 Channel B Low Side TRACE0 Trace Data 4 Notes: No notes
PD_07	InOut	A	PullDown	none	none	VDD_EXT	Desc: PORTD Position 7 LP0 Data 5 PWM1 Channel C High Side TRACE0 Trace Data 5 Notes: No notes
PD_08	InOut	A	PullDown	none	none	VDD_EXT	Desc: PORTD Position 8 LP0 Data 6 PWM1 Channel C Low Side TRACE0 Trace Data 6 TIMER0 Alternate Clock 1 Notes: No notes
PD_09	InOut	A	PullDown	none	none	VDD_EXT	Desc: PORTD Position 9 LP0 Data 7 PWM1 Channel D High Side TRACE0 Trace Data 7 TIMER0 Alternate Clock 2 Notes: No notes
PD_10	InOut	H	PullDown	none	none	VDD_EXT	Desc: PORTD Position 10 LP0 Clock PWM1 Channel D Low Side TRACE0 Trace Clock Notes: No notes
PD_11	InOut	A	PullDown	none	none	VDD_EXT	Desc: PORTD Position 11 LP0 Acknowledge PWM1 PWMTMR Grouped Notes: No notes
PD_12	InOut	A	PullDown	none	none	VDD_EXT	Desc: PORTD Position 12 EPPI0 Data 19 SMC0 Address 6 UART2 Transmit Notes: No notes
PD_13	InOut	A	PullDown	none	none	VDD_EXT	Desc: PORTD Position 13 EPPI0 Data 18 SMC0 Address 5 UART2 Receive TIMER0 Alternate Capture Input 2 Notes: No notes
PD_14	InOut	A	PullDown	none	none	VDD_EXT	Desc: PORTD Position 14 EPPI0 Data 11 MLB0 Single-Ended Clock Out PWM2 Shutdown Input 0 SMC0 Data 6 Notes: No notes
PD_15	InOut	A	PullDown	none	none	VDD_EXT	Desc: PORTD Position 15 EPPI0 Data 10 PWM2 Channel C High Side SMC0 Data 5 Notes: No notes

ADSP-SC582/SC583/SC584/SC587/SC589/ADSP-21583/21584/21587

Table 27. ADSP-SC58x/ADSP-2158x Designer Quick Reference (Continued)

Signal Name	Type	Driver Type	Internal Term	Reset Term	Reset Drive	Power Domain	Description and Notes
PE_00	InOut	A	PullDown	none	none	VDD_EXT	Desc: PORTE Position 0 EPPI0 Data 9 PWM2 Channel C Low Side SMC0 Data 4 Notes: No notes
PE_01	InOut	A	PullDown	none	none	VDD_EXT	Desc: PORTE Position 1 EPPI0 Frame Sync 2 (VSYNC) SPI0 Slave Select Output 5 SHARC Core 1 Flag Pin UART1 Clear to Send Notes: No notes
PE_02	InOut	A	PullDown	none	none	VDD_EXT	Desc: PORTE Position 2 EPPI0 Frame Sync 1 (HSYNC) SPI0 Slave Select Output 6 SHARC Core 2 Flag Pin UART1 Request to Send Notes: No notes
PE_03	InOut	A	PullDown	none	none	VDD_EXT	Desc: PORTE Position 3 EPPI0 Clock SPI0 Slave Select Output 7 SPI2 Slave Select Output 2 SHARC Core 1 Flag Pin Notes: No notes
PE_04	InOut	A	PullDown	none	none	VDD_EXT	Desc: PORTE Position 4 EPPI0 Data 8 PWM2 Channel D High Side SPI2 Slave Select Output 3 SHARC Core 2 Flag Pin Notes: No notes
PE_05	InOut	A	PullDown	none	none	VDD_EXT	Desc: PORTE Position 5 EPPI0 Data 7 PWM2 PWMTMR Grouped SPI2 Slave Select Output 4 SHARC Core 1 Flag Pin Notes: No notes
PE_06	InOut	A	PullDown	none	none	VDD_EXT	Desc: PORTE Position 6 EPPI0 Data 6 SPI2 Slave Select Output 5 SHARC Core 2 Flag Pin Notes: No notes
PE_07	InOut	A	PullDown	none	none	VDD_EXT	Desc: PORTE Position 7 EPPI0 Data 5 SPI1 Slave Select Output 2 SHARC Core 1 Flag Pin Notes: No notes
PE_08	InOut	A	PullDown	none	none	VDD_EXT	Desc: PORTE Position 8 EPPI0 Data 4 SPI1 Ready SPI1 Slave Select Output 5 SHARC Core 2 Flag Pin Notes: No notes
PE_09	InOut	A	PullDown	none	none	VDD_EXT	Desc: PORTE Position 9 EPPI0 Data 3 PWM0 PWMTMR Grouped SMC0 Data 3 TIMER0 Timer 0 Notes: No notes
PE_10	InOut	A	PullDown	none	none	VDD_EXT	Desc: PORTE Position 10 EPPI0 Data 2 PWM2 Channel D Low Side SMC0 Data 2 UART2 Request to Send Notes: No notes

ADSP-SC582/SC583/SC584/SC587/SC589/ADSP-21583/21584/21587

Table 27. ADSP-SC58x/ADSP-2158x Designer Quick Reference (Continued)

Signal Name	Type	Driver Type	Internal Term	Reset Term	Reset Drive	Power Domain	Description and Notes
PE_11	InOut	A	PullDown	none	none	VDD_EXT	Desc: PORTE Position 11 EPPI0 Data 1 SMC0 Data 1 SPI1 Slave Select Output 3 UART2 Clear to Send SPI1 Slave Select Input Notes: No notes
PE_12	InOut	A	PullDown	none	none	VDD_EXT	Desc: PORTE Position 12 EPPI0 Data 0 SMC0 Data 0 SPI1 Slave Select Output 4 SPI2 Ready Notes: No notes
PE_13	InOut	A	PullDown	none	none	VDD_EXT	Desc: PORTE Position 13 EPPI0 Data 20 SMC0 Memory Select 1 SPI1 Clock Notes: No notes
PE_14	InOut	A	PullDown	none	none	VDD_EXT	Desc: PORTE Position 14 EPPI0 Data 21 SMC0 Byte Enable 0 SPI1 Master In, Slave Out Notes: No notes
PE_15	InOut	A	PullDown	none	none	VDD_EXT	Desc: PORTE Position 15 EPPI0 Data 22 SMC0 Byte Enable 1 SPI1 Master Out, Slave In Notes: No notes
PF_00	InOut	A	PullDown	none	none	VDD_EXT	Desc: PORTF Position 0 SPI1 Slave Select Output 6 TIMER0 Timer 6 Notes: No notes
PF_01	InOut	A	PullDown	none	none	VDD_EXT	Desc: PORTF Position 1 SPI1 Slave Select Output 7 TIMER0 Timer 7 Notes: No notes
PF_02	InOut	A	PullDown/ Programmable PullUp	none	none	VDD_EXT	Desc: PORTF Position 2 HADC0 End of Conversion/Serial Data Out MSIO Data 0 Notes: No notes
PF_03	InOut	A	PullDown/ Programmable PullUp	none	none	VDD_EXT	Desc: PORTF Position 3 HADC0 Controls to External Multiplexer MSIO Data 1 Notes: No notes
PF_04	InOut	A	PullDown/ Programmable PullUp	none	none	VDD_EXT	Desc: PORTF Position 4 HADC0 Controls to External Multiplexer MSIO Data 2 Notes: No notes
PF_05	InOut	A	PullDown/ Programmable PullUp	none	none	VDD_EXT	Desc: PORTF Position 5 HADC0 Controls to External Multiplexer MSIO Data 3 Notes: No notes
PF_06	InOut	A	PullDown/ Programmable PullUp	none	none	VDD_EXT	Desc: PORTF Position 6 MSIO Data 4 PWM2 Channel A Low Side Notes: No notes
PF_07	InOut	A	PullDown/ Programmable PullUp	none	none	VDD_EXT	Desc: PORTF Position 7 MSIO Data 5 PWM2 Channel A High Side Notes: No notes

ADSP-SC582/SC583/SC584/SC587/SC589/ADSP-21583/21584/21587

Table 27. ADSP-SC58x/ADSP-2158x Designer Quick Reference (Continued)

Signal Name	Type	Driver Type	Internal Term	Reset Term	Reset Drive	Power Domain	Description and Notes
PF_08	InOut	A	PullDown/ Programmable PullUp	none	none	VDD_EXT	Desc: PORTF Position 8 MSIO Data 6 PWM2 Channel B Low Side Notes: No notes
PF_09	InOut	A	PullDown/ Programmable PullUp	none	none	VDD_EXT	Desc: PORTF Position 9 MSIO Data 7 PWM2 Channel B High Side Notes: No notes
PF_10	InOut	A	PullDown/ Programmable PullUp	none	none	VDD_EXT	Desc: PORTF Position 10 MSIO Command Notes: No notes
PF_11	InOut	A	PullDown	none	none	VDD_EXT	Desc: PORTF Position 11 MSIO Clock Notes: No notes
PF_12	InOut	A	PullDown	none	none	VDD_EXT	Desc: PORTF Position 12 MSIO Card Detect Notes: No notes
PF_13	InOut	A	PullDown	none	none	VDD_EXT	Desc: PORTF Position 13 EMAC1 Carrier Sense/RMII Receive Data Valid MSIO eSDIO Interrupt Input TRACE0 Trace Data TRACE0 Trace Data 8 Notes: No notes
PF_14	InOut	A	PullDown	none	none	VDD_EXT	Desc: PORTF Position 14 EMAC1 Management Channel Clock TRACE0 Trace Data TRACE0 Trace Data 9 Notes: No notes
PF_15	InOut	A	PullDown	none	none	VDD_EXT	Desc: PORTF Position 15 EMAC1 Management Channel Serial Data TRACE0 Trace Data TRACE0 Trace Data 10 Notes: No notes
PG_00	InOut	A	PullDown	none	none	VDD_EXT	Desc: PORTG Position 0 EMAC1 Reference Clock TRACE0 Trace Clock Notes: No notes
PG_01	InOut	A	PullDown	none	none	VDD_EXT	Desc: PORTG Position 1 EMAC1 Transmit Enable TRACE0 Trace Data TRACE0 Trace Data 11 Notes: No notes
PG_02	InOut	A	PullDown	none	none	VDD_EXT	Desc: PORTG Position 2 EMAC1 Transmit Data 0 TRACE0 Trace Data TRACE0 Trace Data 12 Notes: No notes
PG_03	InOut	A	PullDown	none	none	VDD_EXT	Desc: PORTG Position 3 EMAC1 Transmit Data 1 TRACE0 Trace Data TRACE0 Trace Data 13 Notes: No notes
PG_04	InOut	A	PullDown	none	none	VDD_EXT	Desc: PORTG Position 4 EMAC1 Receive Data 0 TRACE0 Trace Data TRACE0 Trace Data 14 Notes: No notes

ADSP-SC582/SC583/SC584/SC587/SC589/ADSP-21583/21584/21587

Table 27. ADSP-SC58x/ADSP-2158x Designer Quick Reference (Continued)

Signal Name	Type	Driver Type	Internal Term	Reset Term	Reset Drive	Power Domain	Description and Notes
PG_05	InOut	A	PullDown	none	none	VDD_EXT	Desc: PORTG Position 5 EMAC1 Receive Data 1 TRACE0 Trace Data TRACE0 Trace Data 15 Notes: No notes
RTC0_CLKIN	a	NA	none	none	none	VDD_RTC	Desc: RTC0 Crystal Input/External Oscillator Connection Notes: Connect to GND if not used
RTC0_XTAL	a	NA	none	none	none	VDD_RTC	Desc: RTC0 Crystal output Notes: No notes
SYS_BMODE0	Input	NA	PullDown	none	none	VDD_EXT	Desc: Boot Mode Control n Notes: No notes
SYS_BMODE1	Input	NA	PullDown	none	none	VDD_EXT	Desc: Boot Mode Control n Notes: No notes
SYS_BMODE2	Input	NA	PullDown	none	none	VDD_EXT	Desc: Boot Mode Control n Notes: No notes
SYS_CLKIN0	a	NA	none	none	none	VDD_EXT	Desc: Clock/Crystal Input Notes: No notes
SYS_CLKIN1	a	NA	none	none	none	VDD_EXT	Desc: Clock/Crystal Input Notes: Connect to GND if not used
SYS_CLKOUT	a	A	none	none	none		Desc: Processor Clock Output Notes: No notes
SYS_FAULT	InOut	A	none	none	none		Desc: Active-High Fault Output Notes: External pull-down required to keep signal in de-asserted state
<u>SYS_FAULT</u>	InOut	A	none	none	none		Desc: Active-Low Fault Output Notes: External pull-up required to keep signal in de-asserted state
<u>SYS_HWRST</u>	Input	NA	none	none	none	VDD_EXT	Desc: Processor Hardware Reset Control Notes: No notes
<u>SYS_RESOUT</u>	Output	A	none	none	L	VDD_EXT	Desc: Reset Output Notes: No notes
SYS_XTAL0	a	NA	none	none	none	VDD_EXT	Desc: Crystal Output Notes: No notes
SYS_XTAL1	a	NA	none	none	none	VDD_EXT	Desc: Crystal Output Notes: No notes
TWI0_SCL	InOut	D	none	none	none	VDD_EXT	Desc: TWI0 Serial Clock Notes: Add external pull-up if used. Can be pulled low when not used.
TWI0_SDA	InOut	D	none	none	none	VDD_EXT	Desc: TWI0 Serial Data Notes: Add external pull-up if used. Can be pulled low when not used.
TWI1_SCL	InOut	D	none	none	none	VDD_EXT	Desc: TWI1 Serial Clock Notes: Add external pull-up if used. Can be pulled low when not used.
TWI1_SDA	InOut	D	none	none	none	VDD_EXT	Desc: TWI1 Serial Data Notes: Add external pull-up if used. Can be pulled low when not used.

ADSP-SC582/SC583/SC584/SC587/SC589/ADSP-21583/21584/21587

Table 27. ADSP-SC58x/ADSP-2158x Designer Quick Reference (Continued)

Signal Name	Type	Driver Type	Internal Term	Reset Term	Reset Drive	Power Domain	Description and Notes
TWI2_SCL	InOut	D	none	none	none	VDD_EXT	Desc: TWI2 Serial Clock Notes: Add external pull-up if used. Can be pulled low when not used.
TWI2_SDA	InOut	D	none	none	none	VDD_EXT	Desc: TWI2 Serial Data Notes: Add external pull-up if used. Can be pulled low when not used.
USB0_DM	InOut	F	none	none	none	VDD_USB	Desc: USB0 Data – Notes: Add external pull-down if not used ¹
USB0_DP	InOut	F	none	none	none	VDD_USB	Desc: USB0 Data + Notes: Add external pull-down if not used ¹
USB0_ID	InOut		none	none	none	VDD_USB	Desc: USB0 OTG ID Notes: Connect to GND when USB is not used ¹
USB0_VBC	InOut	E	none	none	none	VDD_USB	Desc: USB0 VBUS Control Notes: Add external pull-down if not used ¹
USB0_VBUS	InOut	G	none	none	none	VDD_USB	Desc: USB0 Bus Voltage Notes: Connect to GND if not used ¹
USB1_DM	InOut	F	none	none	none	VDD_USB	Desc: USB1 Data – Notes: Add external pull-down if not used ¹
USB1_DP	InOut	F	none	none	none	VDD_USB	Desc: USB1 Data + Notes: Add external pull-down if not used ¹
USB1_VBUS	InOut	G	none	none	none	VDD_USB	Desc: USB1 Bus Voltage Notes: Connect to GND if not used ¹
USB_CLKIN	a		none	none	none		Desc: USB0/USB1 Clock/Crystal Input Notes: Services both USB0 and USB1. Connect to GND if not used. ¹
USB_XTAL	a		none	none	none		Desc: USB0/USB1 Crystal Notes: Services both USB0 and USB1
VDD_DMC	s	NA	none	none	none		Desc: DMC VDD Notes: No notes
VDD_EXT	s	NA	none	none	none		Desc: External Voltage Domain Notes: No notes
VDD_HADC	s	NA	none	none	none		Desc: HADC/TMU VDD Notes: Can be left floating if HADC and TMU are not used
VDD_INT	s	NA	none	none	none		Desc: Internal Voltage Domain Notes: No notes
VDD_PCIE	s	NA	none	none	none		Desc: PCIE Supply Voltage Notes: Connect to GND if not used ^{1,2}
VDD_PCIE_RX	s	NA	none	none	none		Desc: PCIE RX Supply Voltage Notes: Connect to GND if not used ^{1,2}
VDD_PCIE_TX	s	NA	none	none	none		Desc: PCIE TX Supply Voltage Notes: Connect to GND if not used ^{1,2}

ADSP-SC582/SC583/SC584/SC587/SC589/ADSP-21583/21584/21587

Table 27. ADSP-SC58x/ADSP-2158x Designer Quick Reference (Continued)

Signal Name	Type	Driver Type	Internal Term	Reset Term	Reset Drive	Power Domain	Description and Notes
VDD_RTC	s	NA	none	none	none		Desc: RTC VDD Notes: No notes
VDD_USB	s	NA	none	none	none		Desc: USB VDD Notes: Connect to VDD_EXT when USB is not used

¹Guidance also applies to models that do not feature the associated hardware block. See [Table 2](#) or [Table 3](#) for further information.

²For boundary scan to work, PCIE power supplies must be connected as per [Specifications](#).

ADSP-SC582/SC583/SC584/SC587/SC589/ADSP-21583/21584/21587

SPECIFICATIONS

Specifications are subject to change without notice. For information about product specifications, contact your Analog Devices, Inc., representative.

OPERATING CONDITIONS

Parameter	Conditions	Min	Nominal	Max	Unit	
V _{DD_INT}	Internal (Core) Supply Voltage	CCLK ≤ 450 MHz	1.05	1.10	1.15	V
		CCLK ≤ 500 MHz	1.10	1.15	1.20	V
V _{DD_EXT}	External (I/O) Supply Voltage	3.13	3.3	3.47	V	
V _{DD_HADC}	Analog Power Supply Voltage	3.13	3.3	3.47	V	
V _{DD_DMC} ¹	DDR2/LPDDR Controller Supply Voltage		1.7	1.8	1.9	V
		DDR3 Controller Supply Voltage	1.425	1.5	1.575	V
V _{DD_USB} ²	USB Supply Voltage	3.13	3.3	3.47	V	
V _{DD_RTC}	RTC Voltage	2.0	3.3	3.60	V	
V _{DD_PCIE_TX}	PCIe Core Transmit Voltage	1.05	1.1	1.15	V	
V _{DD_PCIE_RX}	PCIe Core Receive Voltage	1.05	1.1	1.15	V	
V _{DD_PCIE}	PCIe Voltage	3.13	3.3	3.47	V	
V _{DDR_VREF} ³	DDR2/DDR3 Reference Voltage	0.49 × V _{DD_DMC}	0.50 × V _{DD_DMC}	0.51 × V _{DD_DMC}	V	
V _{HADC_REF} ⁴	HADC Reference Voltage	2.5	3.30	V _{DD_HADC}	V	
V _{HADC0_VINx}	HADC Input Voltage	0		V _{HADC_REF} + 0.2	V	
V _{IH} ⁵	High Level Input Voltage	V _{DD_EXT} = 3.47 V			V	
V _{IHTWI} ^{6,7}	High Level Input Voltage	V _{DD_EXT} = 3.47 V	0.7 × V _{BUSTWI}	V _{BUSTWI}	V	
V _{IL} ⁵	Low Level Input Voltage	V _{DD_EXT} = 3.13 V		0.8	V	
V _{ILTWI} ^{6,7}	Low Level Input Voltage	V _{DD_EXT} = 3.13 V		0.3 × V _{BUSTWI}	V	
V _{IL_DDR2} ⁸	Low Level Input Voltage	V _{DD_DMC} = 1.7 V		V _{DDR_VREF} - 0.25	V	
V _{IL_DDR3} ⁸	Low Level Input Voltage	V _{DD_DMC} = 1.425 V		V _{DDR_VREF} - 0.175	V	
V _{IH_DDR2} ⁸	High Level Input Voltage	V _{DD_DMC} = 1.9 V	V _{DDR_VREF} + 0.25		V	
V _{IH_DDR3} ⁸	High Level Input Voltage	V _{DD_DMC} = 1.575 V	V _{DDR_VREF} + 0.175		V	
V _{IL_LPDDR} ⁹	Low Level Input Voltage	V _{DD_DMC} = 1.7 V		0.2 × V _{DD_DMC}	V	
V _{IH_LPDDR} ⁹	High Level Input Voltage	V _{DD_DMC} = 1.9 V	0.8 × V _{DD_DMC}		V	
T _J	Junction Temperature 349-Lead CSP_BGA	T _{AMBIENT} = 0°C to 70°C CCLK ≤ 450 MHz	0	100	°C	
T _J	Junction Temperature 349-Lead CSP_BGA	T _{AMBIENT} = -40°C to +85°C CCLK ≤ 450 MHz	-40	+110	°C	
T _J	Junction Temperature 349-Lead CSP_BGA	T _{AMBIENT} = -40°C to +95°C CCLK ≤ 450 MHz	-40	+125	°C	
T _J	Junction Temperature 529-Lead CSP_BGA	T _{AMBIENT} = 0°C to 70°C CCLK ≤ 450 MHz	0	110	°C	
T _J	Junction Temperature 529-Lead CSP_BGA	T _{AMBIENT} = -40°C to +85°C CCLK ≤ 450 MHz	-40	+125	°C	
T _J	Junction Temperature 349-Lead CSP_BGA	T _{AMBIENT} = 0°C to 70°C CCLK ≤ 500 MHz	0	105	°C	
T _J	Junction Temperature 349-Lead CSP_BGA	T _{AMBIENT} = -40°C to +85°C CCLK ≤ 500 MHz	-40	+120	°C	
T _J	Junction Temperature 349-Lead CSP_BGA	T _{AMBIENT} = -40°C to +90°C CCLK ≤ 500 MHz	-40	+125	°C	
T _J	Junction Temperature 529-Lead CSP_BGA	T _{AMBIENT} = 0°C to 70°C CCLK ≤ 500 MHz	0	115	°C	
T _J	Junction Temperature 529-Lead CSP_BGA	T _{AMBIENT} = -40°C to +80°C CCLK ≤ 500 MHz	-40	+125	°C	

ADSP-SC582/SC583/SC584/SC587/SC589/ADSP-21583/21584/21587

Parameter	Conditions	Min	Nominal	Max	Unit
AUTOMOTIVE USE ONLY					
T _J	Junction Temperature 349-Lead CSP_BGA (Automotive Grade) ¹⁰	T _{AMBIENT} = -40°C to +105°C CCLK ≤ 450 MHz		+133	°C
T _J	Junction Temperature 529-Lead CSP_BGA (Automotive Grade) ¹⁰	T _{AMBIENT} = -40°C to +90°C CCLK ≤ 450 MHz		+133	°C
T _J	Junction Temperature 349-Lead CSP_BGA (Automotive Grade) ¹⁰	T _{AMBIENT} = -40°C to +100°C CCLK ≤ 500 MHz		+133	°C
T _J	Junction Temperature 529-Lead CSP_BGA (Automotive Grade) ¹⁰	T _{AMBIENT} = -40°C to +85°C CCLK ≤ 500 MHz		+133	°C

¹Applies to DDR2/DDR3/LPDDR signals.

²If not used, V_{DD_USB} must be connected to 3.3 V.

³Applies to DMC0_VREF and DMC1_VREF pins.

⁴V_{HADC_VREF} must always be less than V_{DD_HADC}.

⁵Parameter value applies to all input and bidirectional pins except the TWI, DMC, USB, PCIe, and MLB pins.

⁶Parameter applies to TWI signals.

⁷TWI signals are pulled up to V_{BUSTWI}. See [Table 28](#).

⁸This parameter applies to all DMC0/1 signals in DDR2/DDR3 mode.

⁹This parameter applies to DMC0/1 signals in LPDDR mode.

¹⁰Automotive application use profile only. Not supported for nonautomotive use. Contact Analog Devices for more information.

Table 28. TWIxVSEL¹ Settings and V_{DD_EXT}/V_{BUSTWI}

TWIxVSEL	V _{DD_EXT} Nominal	V _{BUSTWI}			Unit
		Min	Nominal	Max	
0 ²	3.30	3.13	3.30	3.47	V
1	3.30	4.75	5.00	5.25	V

¹TWIxVSEL are the TWI voltage select bits in the PADS_PCFG0 register. See the [ADSP-SC58x/ADSP-2158x SHARC+ Processor Hardware Reference](#).

²Designs must comply with the V_{DD_EXT} and V_{BUSTWI} voltages specified for the default TWIxVSEL setting for correct JTAG boundary scan operation during reset.

ADSP-SC582/SC583/SC584/SC587/SC589/ADSP-21583/21584/21587

Clock Related Operating Conditions

Table 29 describes the core clock, system clock, and peripheral clock timing requirements. The data presented in the table applies to all speed grades except where noted.

Table 29. Clock Operating Conditions

Parameter	Restriction	Min	Typ	Max	Unit
f _{CCLK} Core Clock Frequency	f _{CCLK} ≥ f _{SYCLK}	100		500	MHz
f _{SYCLK} SYCLK Frequency ¹				250	MHz
f _{SCLK0} SCLK0 Frequency ²	f _{SYCLK} ≥ f _{SCLK0}	30		125	MHz
f _{SCLK1} SCLK1 Frequency	f _{SYCLK} ≥ f _{SCLK1}			125	MHz
f _{DCLK} LPDDR Clock Frequency				200	MHz
f _{DCLK} DDR2 Clock Frequency				400	MHz
f _{DCLK} DDR3 Clock Frequency				450	MHz
f _{OCLK} Output Clock Frequency ³				250	MHz
f _{SYS_CLKOUTJ} SYS_CLKOUT Period Jitter ^{4, 5}			±2		%
f _{PCLKPROG} Programmed PPI Clock When Transmitting Data and Frame Sync				75	MHz
f _{PCLKPROG} Programmed PPI Clock When Receiving Data or Frame Sync				45	MHz
f _{PCLKEXT} External PPI Clock When Receiving Data and Frame Sync ^{6, 7}	f _{PCLKEXT} ≤ f _{SCLK1}			75	MHz
f _{PCLKEXT} External PPI Clock Transmitting Data or Frame Sync ^{6, 7}	f _{PCLKEXT} ≤ f _{SCLK1}			45	MHz
f _{LCLKTPROG} Programmed Link Port Transmit Clock				150	MHz
f _{LCLKREXT} External Link Port Receive Clock ^{6, 7}	f _{LCLKEXT} ≤ f _{CLK08}			150	MHz
f _{SPTCLKPROG} Programmed SPT Clock When Transmitting Data and Frame Sync				62.5	MHz
f _{SPTCLKPROG} Programmed SPT Clock When Receiving Data or Frame Sync				31.25	MHz
f _{SPTCLKEXT} External SPT Clock When Receiving Data and Frame Sync ^{6, 7}	f _{SPTCLKEXT} ≤ f _{SCLK0}			62.5	MHz
f _{SPTCLKEXT} External SPT Clock Transmitting Data or Frame Sync ^{6, 7}	f _{SPTCLKEXT} ≤ f _{SCLK0}			31.25	MHz
f _{SPICLKPROG} Programmed SPI Clock When Transmitting Data				75	MHz
f _{SPICLKPROG} Programmed SPI Clock When Receiving Data				75	MHz
f _{SPICLKEXT} External SPI Clock When Receiving Data ^{6, 7}	f _{SPICLKEXT} ≤ f _{SCLK1}			75	MHz
f _{SPICLKEXT} External SPI Clock When Transmitting Data ^{6, 7}	f _{SPICLKEXT} ≤ f _{SCLK1}			45	MHz
f _{ACLKPROG} Programmed ACM Clock				62.5	MHz

¹When using MLB, there is a requirement that the f_{SYCLK} value must be a minimum of 100 MHz for both 3-pin and 6-pin modes and for all supported speeds.

²The minimum frequency for SCLK0 applies only when using the USB.

³f_{OCLK} must not exceed f_{SCLK0} when selected as SYS_CLKOUT.

⁴SYS_CLKOUT jitter is dependent on the application system design including pin switching activity, board layout, and the jitter characteristics of the SYS_CLKIN source. Due to the dependency on these factors, the measured jitter may be higher or lower than this typical specification for each end application.

⁵The value in the Typ field is the percentage of the SYS_CLKOUT period.

⁶The maximum achievable frequency for any peripheral in external clock mode is dependent on the ability to meet the setup and hold times in the ac timing specifications section for that peripheral.

⁷The peripheral external clock frequency must also be less than or equal to the f_{SCLK} (f_{SCLK0} or f_{SCLK1}) that clocks the peripheral.

ADSP-SC582/SC583/SC584/SC587/SC589/ADSP-21583/21584/21587

Table 30. Phase-Locked Loop (PLL) Operating Conditions

Parameter		Min	Max	Unit
f_{PLLCLK}	PLL Clock Frequency	200	1000	MHz

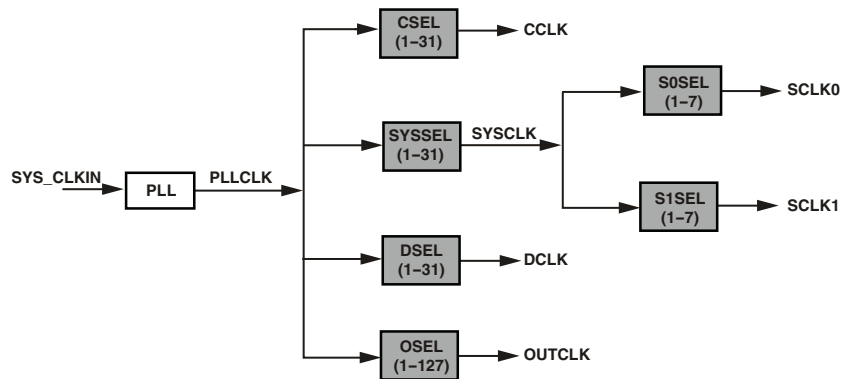

Figure 8. Clock Relationships and Divider Values

ADSP-SC582/SC583/SC584/SC587/SC589/ADSP-21583/21584/21587

ELECTRICAL CHARACTERISTICS

Parameter	Conditions	Min	Typ	Max	Unit
V_{OH}^1	High Level Output Voltage	At V_{DD_EXT} = minimum, $I_{OH} = -1.0 \text{ mA}^2$	2.4		V
V_{OL}^1	Low Level Output Voltage	At V_{DD_EXT} = minimum, $I_{OL} = 1.0 \text{ mA}^2$		0.4	V
$V_{OH_DDR2}^3$	High Level Output Voltage for DDR2 DS = 40 Ω	At V_{DD_DDR} = minimum, $I_{OH} = -5.8 \text{ mA}$	1.38		V
$V_{OL_DDR2}^3$	Low Level Output Voltage for DDR2 DS = 40 Ω	At V_{DD_DDR} = minimum, $I_{OL} = 5.8 \text{ mA}$		0.32	V
$V_{OH_DDR2}^3$	High Level Output Voltage for DDR2 DS = 60 Ω	At V_{DD_DDR} = minimum, $I_{OH} = -3.4 \text{ mA}$	1.38		V
$V_{OL_DDR2}^3$	Low Level Output Voltage for DDR2 DS = 60 Ω	At V_{DD_DDR} = minimum, $I_{OL} = 3.4 \text{ mA}$		0.32	V
$V_{OH_DDR3}^4$	High Level Output Voltage for DDR3 DS = 40 Ω	At V_{DD_DDR} = minimum, $I_{OH} = -5.8 \text{ mA}$	1.105		V
$V_{OL_DDR3}^4$	Low Level Output Voltage for DDR3 DS = 40 Ω	At V_{DD_DDR} = minimum, $I_{OL} = 5.8 \text{ mA}$		0.32	V
$V_{OH_DDR3}^4$	High Level Output Voltage for DDR3 DS = 60 Ω	At V_{DD_DDR} = minimum, $I_{OH} = -3.4 \text{ mA}$	1.105		V
$V_{OL_DDR3}^4$	Low Level Output Voltage for DDR3 DS = 60 Ω	At V_{DD_DDR} = minimum, $I_{OL} = 3.4 \text{ mA}$		0.32	V
$V_{OH_LPDDR}^5$	High Level Output Voltage for LPDDR	At V_{DD_DDR} = minimum, $I_{OH} = -6.0 \text{ mA}$	1.38		V
$V_{OL_LPDDR}^5$	Low Level Output Voltage for LPDDR	At V_{DD_DDR} = minimum, $I_{OL} = 6.0 \text{ mA}$		0.32	V
$I_{IH}^{6,7}$	High Level Input Current	At V_{DD_EXT} = maximum, $V_{IN} = V_{DD_EXT}$ maximum		10	μA
I_{IL}^6	Low Level Input Current	At V_{DD_EXT} = maximum, $V_{IN} = 0 \text{ V}$		10	μA
$I_{IL_PU}^7$	Low Level Input Current Pull-Up	At V_{DD_EXT} = maximum, $V_{IN} = 0 \text{ V}$		200	μA
$I_{IH_PD}^8$	High Level Input Current Pull-Down	At V_{DD_EXT} = maximum, $V_{IN} = V_{DD_EXT}$ maximum		200	μA
I_{OZH}^9	Three-State Leakage Current	At V_{DD_EXT}/V_{DD_DDR} = maximum, $V_{IN} = V_{DD_EXT}/V_{DD_DDR}$ maximum		10	μA
I_{OZL}^9	Three-State Leakage Current	at V_{DD_EXT}/V_{DD_DDR} = maximum, $V_{IN} = 0 \text{ V}$		10	μA
C_{IN}^{10}	Input Capacitance	$T_{CASE} = 25^\circ\text{C}$		5	pF
I_{DD_IDLE}	V_{DD_INT} Current in Idle	$f_{CCLK} = 450 \text{ MHz}$ $ASF_{SHARC1} = 0.31$ $ASF_{SHARC2} = 0.31$ $ASF_{A5} = 0.29$ $f_{SYSCLK} = 225 \text{ MHz}$ $f_{SCLK0/1} = 112.5 \text{ MHz}$ (Other clocks are disabled) No peripheral or DMA activity $T_J = 25^\circ\text{C}$ $V_{DD_INT} = 1.1 \text{ V}$	495		mA

ADSP-SC582/SC583/SC584/SC587/SC589/ADSP-21583/21584/21587

Parameter	Conditions	Min	Typ	Max	Unit
I _{DD_IDLE} V _{DD_INT} Current in Idle	f _{CCLK} = 500 MHz ASF _{SHARC1} = 0.31 ASF _{SHARC2} = 0.31 ASF _{A5} = 0.29 f _{SYSCLK} = 250 MHz f _{SCLK0/1} = 125 MHz (Other clocks are disabled) No peripheral or DMA activity T _J = 25°C V _{DD_INT} = 1.15 V		575		mA
I _{DD_TYP} V _{DD_INT} Current	f _{CCLK} = 450 MHz ASF _{SHARC1} = 1.0 ASF _{SHARC2} = 1.0 ASF _{A5} = 0.73 f _{SYSCLK} = 225 MHz f _{SCLK0/1} = 112.5 MHz (Other clocks are disabled) FFT accelerator operating at f _{SYSCLK/4} DMA data rate = 600 Mbps T _J = 25°C V _{DD_INT} = 1.1 V		1112		mA
I _{DD_TYP} V _{DD_INT} Current	f _{CCLK} = 500 MHz ASF _{SHARC1} = 1.0 ASF _{SHARC2} = 1.0 ASF _{A5} = 0.73 f _{SYSCLK} = 250 MHz f _{SCLK0/1} = 125 MHz (Other clocks are disabled) FFT accelerator operating at f _{SYSCLK/4} DMA data rate = 600 Mbps T _J = 25°C V _{DD_INT} = 1.15 V		1185		mA
I _{DD_INT} ¹¹ V _{DD_INT} Current	f _{CCLK} > 0 MHz f _{SCLK0/1} ≥ 0 MHz			See I _{DD_INT_TOT} equation in the Total Internal Power Dissipation section	mA

¹ Applies to all output and bidirectional pins except TWI, DMC, USB, PCIe, and MLB.

² See the [Output Drive Currents](#) section for typical drive current capabilities.

³ Applies to all DMC output and bidirectional signals in DDR2 mode.

⁴ Applies to all DMC output and bidirectional signals in DDR3 mode.

⁵ Applies to all DMC output and bidirectional signals in LPDDR mode.

⁶ Applies to input pins SYS_BMODE0-2, SYS_CLKIN0, SYS_CLKIN1, SYS_HWRST, JTG_TDI, JTG_TMS, and USB0_CLKIN.

⁷ Applies to input pins with internal pull-ups including JTG_TDI, JTG_TMS, and JTG_TCK.

⁸ Applies to signals JTAG_TRST, USB0_VBUS, USB1_VBUS.

⁹ Applies to signals PA0-15, PB0-15, PC0-15, PD0-15, PE0-15, PF0-15, PG0-5, DAI0_PINx, DAI1_PINx, DMC0_DQx, DMC0_LDQs, DMC0_UDQs, DMC0_LDQs, DMC0_UDQs, SYS_FAULT, SYS_FAULT, JTG_TDO, USB0_ID, USBx_DM, USBx_DP, and USBx_VBC.

¹⁰ Applies to all signal pins.

¹¹ See [Estimating Power for ADSP-SC58x/2158x SHARC+ Processors \(EE-392\)](#) for further information.

ADSP-SC582/SC583/SC584/SC587/SC589/ADSP-21583/21584/21587

Total Internal Power Dissipation

Total power dissipation has two components:

- Static, including leakage current
- Dynamic, due to transistor switching characteristics for each clock domain

Many operating conditions can affect power dissipation, including temperature, voltage, operating frequency, and processor activity. The following equation describes the internal current consumption.

$$I_{DD_INT_TOT} = I_{DD_INT_STATIC} + I_{DD_INT_CCLK_SHARC1_DYN} + I_{DD_INT_CCLK_SHARC2_DYN} + I_{DD_INT_CCLK_A5_DYN} + I_{DD_INT_DCLK_DYN} + I_{DD_INT_SYSCLK_DYN} + I_{DD_INT_SCLK0_DYN} + I_{DD_INT_SCLK1_DYN} + I_{DD_INT_OCLK_DYN} + I_{DD_INT_ACCL_DYN} + I_{DD_INT_USB_DYN} + I_{DD_INT_MLB_DYN} + I_{DD_INT_EMAC_DYN} + I_{DD_INT_DMA_DR_DYN} + I_{DD_INT_PCIE_DYN}$$

$I_{DD_INT_STATIC}$ is the sole contributor to the static power dissipation component and is specified as a function of voltage (V_{DD_INT}) and junction temperature (T_J) in Table 31.

Table 31. Static Current— $I_{DD_INT_STATIC}$ (mA)

T_J (°C)	Voltage (V_{DD_INT})			
	1.05	1.10	1.15	1.20
-40	7	8	10	12
-20	12	14	17	21
-10	16	19	23	27
+0	21	25	30	35
+10	28	33	39	46
+25	42	49	58	67
+40	63	73	84	98
+55	92	106	122	141
+70	133	152	175	200
+85	190	216	247	282
+100	269	305	346	393
+105	302	342	387	439
+115	376	425	480	544
+125	466	525	592	669
+133	552	621	700	789

The other 14 addends in the $I_{DD_INT_TOT}$ equation comprise the dynamic power dissipation component and fall into four broad categories: application-dependent currents, clock currents, currents from high speed peripheral operation, and data transmission currents.

Application Dependent Current

The application dependent currents include the dynamic current in the core clock domain of the two SHARC+ cores and the Arm Cortex-A5 core, as well as the dynamic current in the accelerator block.

Dynamic current consumed by the core is subject to an activity scaling factor (ASF) that represents application code running on the processor cores (see Table 32 and Table 33). The ASF is combined with the CCLK frequency and V_{DD_INT} dependent dynamic current data in Table 34 and Table 35, respectively, to calculate this portion of the total dynamic power dissipation component.

$$I_{DD_INT_CCLK_SHARC1_DYN} = \text{Table 34} \times ASF_{SHARC1}$$

$$I_{DD_INT_CCLK_SHARC2_DYN} = \text{Table 34} \times ASF_{SHARC2}$$

$$I_{DD_INT_CCLK_A5_DYN} = \text{Table 35} \times ASF_{A5}$$

Table 32. Activity Scaling Factors for the SHARC+ Core1 and Core2 (ASF_{SHARC1} and ASF_{SHARC2})

I_{DD_INT} Power Vector	ASF
I_{DD_IDLE}	0.31
I_{DD_NOP}	0.53
$I_{DD_TYP_3070}$	0.74
$I_{DD_TYP_5050}$	0.87
$I_{DD_TYP_7030}$	1.00
$I_{DD_PEAK_100}$	1.14

Table 33. Activity Scaling Factors for the Arm Cortex-A5 Core (ASF_{A5})

I_{DD_INT} Power Vector	ASF
I_{DD_IDLE}	0.29
$I_{DD_DHRYSTONE}$	0.73
$I_{DD_TYP_2575}$	0.57
$I_{DD_TYP_5050}$	0.80
$I_{DD_TYP_7525}$	1.00
$I_{DD_PEAK_100}$	1.21

ADSP-SC582/SC583/SC584/SC587/SC589/ADSP-21583/21584/21587

Table 34. Dynamic Current for Each SHARC+ Core (mA, with ASF = 1.00)¹

f _{CCLK} (MHz)	Voltage (V _{DD_INT})			
	1.05	1.10	1.15	1.20
500	N/A	374	391	408
450	321	337	352	367
400	286	299	313	326
350	250	262	274	286
300	214	224	235	245
250	179	187	196	204
200	143	150	156	163
150	107	112	117	122
100	71	75	78	82

¹N/A means not applicable.

Table 35. Dynamic Current for the Arm Cortex-A5 Core (mA, with ASF = 1.00)¹

f _{CCLK} (MHz)	Voltage (V _{DD_INT})			
	1.05	1.10	1.15	1.20
500	N/A	83	86	90
450	71	74	78	81
400	63	66	69	72
350	55	58	60	63
300	47	50	52	54
250	39	41	43	45
200	32	33	35	36
150	24	25	26	27
100	16	17	18	19

¹N/A means not applicable.

The following equation is used to compute the power dissipation when the FFT accelerator is used:

$$I_{DD_INT_ACCL_DYN} \text{ (mA)} = ASF_{ACCL} \times f_{SYSCLK} \text{ (MHz)} \times V_{DD_INT} \text{ (V)}$$

Table 36. Activity Scaling Factors for the FFT Accelerator (ASF_{ACCL})

I _{DD_INT} Power Vector	ASF _{ACCL}
Unused	0.0
I _{DD-TYP}	0.32

Clock Current

The dynamic clock currents provide the total power dissipated by all transistors switching in the clock paths. The power dissipated by each clock domain is dependent on voltage (V_{DD_INT}), operating frequency, and a unique scaling factor.

$$I_{DD_INT_SYSCLK_DYN} \text{ (mA)} = 0.78 \times f_{SYSCLK} \text{ (MHz)} \times V_{DD_INT} \text{ (V)}$$

$$I_{DD_INT_SCLK0_DYN} \text{ (mA)} = 0.44 \times f_{SCLK0} \text{ (MHz)} \times V_{DD_INT} \text{ (V)}$$

$$I_{DD_INT_SCLK1_DYN} \text{ (mA)} = 0.06 \times f_{SCLK1} \text{ (MHz)} \times V_{DD_INT} \text{ (V)}$$

$$I_{DD_INT_DCLK_DYN} \text{ (mA)} = 0.14 \times f_{DCLK} \text{ (MHz)} \times V_{DD_INT} \text{ (V)}$$

$$I_{DD_INT_OCLK_DYN} \text{ (mA)} = 0.02 \times f_{OCLK} \text{ (MHz)} \times V_{DD_INT} \text{ (V)}$$

Current from High Speed Peripheral Operation

The following modules contribute significantly to power dissipation, and a single term is added when the modules are used.

$$I_{DD_INT_USB_DYN} = 20 \text{ mA (if both USBs are enabled in HS mode)}$$

$$I_{DD_INT_MLB_DYN} = 10 \text{ mA (if MLB 6-pin interface is enabled)}$$

$$I_{DD_INT_EMAC_DYN} = 10 \text{ mA (if EMAC is enabled)}$$

$$I_{DD_INT_PCIE_DYN} = 240 \text{ mA (if PCIe is enabled in 5 Gbps mode)}$$

Data Transmission Current

The data transmission current represents the power dissipated when moving data throughout the system via direct memory access (DMA). This current is proportional to the data rate. Refer to the power calculator available with [Estimating Power for ADSP-SC58x/2158x SHARC+ Processors \(EE-392\)](#) to estimate I_{DD_INT_DMA_DR_DYN} based on the bandwidth of the data transfer.

ADSP-SC582/SC583/SC584/SC587/SC589/ADSP-21583/21584/21587

HADC

HADC Electrical Characteristics

Table 37. HADC Electrical Characteristics

Parameter	Conditions	Typ	Unit
I _{DD_HADC_IDLE}	Current consumption on V _{DD_HADC} . HADC is powered on, but not converting.	2.0	mA
I _{DD_HADC_ACTIVE}	Current consumption on V _{DD_HADC} during a conversion.	2.5	mA
I _{DD_HADC_POWERDOWN}	Current consumption on V _{DD_HADC} . Analog circuitry of the HADC is powered down.	10	μA

HADC DC Accuracy

Table 38. HADC DC Accuracy¹

Parameter	Typ	Unit ²
Resolution	12	Bits
No Missing Codes (NMC)	10	Bits
Integral Nonlinearity (INL)	±2	LSB
Differential Nonlinearity (DNL)	±2	LSB
Offset Error	±8	LSB
Offset Error Matching	±10	LSB
Gain Error	±4	LSB
Gain Error Matching	±4	LSB

¹ See the [Operating Conditions](#) section for the HADC0_VINx specification.

² LSB = HADC0_VREFP ÷ 4096.

HADC Timing Specifications

Table 39. HADC Timing Specifications

Parameter	Typ	Max	Unit
Conversion Time	20 × T _{SAMPLE}		μs
Throughput Range		1	MSPS
T _{WAKEUP}		100	μs

TMU

TMU Characteristics

Table 40. TMU Characteristics

Parameter	Typ	Unit
Resolution	1	°C
Accuracy	±6	°C

Table 41. TMU Gain and Offset

Junction Temperature Range	TMU_GAIN	TMU_OFFSET
-40°C to +40°C	Contact Analog Devices, Inc.	
40°C to 85°C	Contact Analog Devices, Inc.	
85°C to 133°C	Contact Analog Devices, Inc.	

ADSP-SC582/SC583/SC584/SC587/SC589/ADSP-21583/21584/21587

ABSOLUTE MAXIMUM RATINGS

Stresses at or above those listed in [Table 42](#) may cause permanent damage to the product. This is a stress rating only; functional operation of the product at these or any other conditions above those indicated in the operational section of this specification is not implied. Operation beyond the maximum operating conditions for extended periods may affect product reliability.

Table 42. Absolute Maximum Ratings

Parameter	Rating
Internal (Core) Supply Voltage (V_{DD_INT})	-0.33 V to +1.26 V
External (I/O) Supply Voltage (V_{DD_EXT})	-0.33 V to +3.60 V
DDR2/LPDDR Controller Supply Voltage (V_{DD_DMC})	-0.33 V to +1.90 V
DDR3 Controller Supply Voltage (V_{DD_DMC})	-0.33 V to +1.60 V
USB PHY Supply Voltage (V_{DD_USB})	-0.33 V to +3.60 V
Real-Time Clock Supply Voltage (V_{DD_RTC})	-0.33 V to +3.60 V
PCIe Transmit Supply Voltage ($V_{DD_PCIE_TX}$)	-0.33 V to +1.20 V
PCIe Receive Supply Voltage ($V_{DD_PCIE_RX}$)	-0.33 V to +1.20 V
PCIe Supply Voltage (V_{DD_PCIE})	-0.33 V to +3.60 V
HADC Supply Voltage (V_{DD_HADC})	-0.33 V to +3.60 V
HADC Reference Voltage (V_{HADC_REF})	-0.33 V to +3.60 V
DDR2/LPDDR Input Voltage ¹	-0.33 V to +1.90 V
DDR2 Reference Voltage (V_{DDR_VREF})	-0.33 V to +1.90 V
DDR3 Input Voltage ¹	-0.33 V to +1.60 V
Digital Input Voltage ^{1, 2}	-0.33 V to +3.60 V
TWI Input Voltage ^{1, 3}	-0.33 V to +5.50 V
USB0_Dx Input Voltage ^{1, 4}	-0.33 V to +5.25 V
USB0_VBUS Input Voltage ^{1, 4}	-0.33 V to +6 V
Output Voltage Swing	-0.33 V to $V_{DD_EXT} + 0.5$ V
Analog Input Voltage ⁵	-0.2 V to $V_{DD_HADC} + 0.2$ V
I_{OH}/I_{OL} Current per Signal ²	6 mA (maximum)
Storage Temperature Range	-65°C to +150°C
Junction Temperature While Biased	133°C

¹ Applies only when the related power supply (V_{DD_DMC} , V_{DD_EXT} , or V_{DD_USB}) is within specification. When the power supply is below specification, the range is the voltage being applied to that power domain ± 0.2 V.

² Applies to 100% transient duty cycle.

³ Applies to TWI_SCL and TWI_SDA.

⁴ If the USB is not used, connect these pins according to [Table 27](#).

⁵ Applies only when V_{DD_HADC} is within specifications and ≤ 3.4 V. When V_{DD_HADC} is within specifications and > 3.4 V, the maximum rating is 3.6 V. When V_{DD_HADC} is below specifications, the range is $V_{DD_HADC} \pm 0.2$ V.

ESD CAUTION



ESD (electrostatic discharge) sensitive device.

Charged devices and circuit boards can discharge without detection. Although this product features patented or proprietary protection circuitry, damage may occur on devices subjected to high energy ESD. Therefore, proper ESD precautions should be taken to avoid performance degradation or loss of functionality.

ADSP-SC582/SC583/SC584/SC587/SC589/ADSP-21583/21584/21587

TIMING SPECIFICATIONS

Power-Up Reset Timing

Table 43 and Figure 9 show the relationship between power supply startup and processor reset timing, related to the clock generation unit (CGU) and reset control unit (RCU).

In Figure 9, $V_{DD_SUPPLIES}$ are V_{DD_INT} , V_{DD_EXT} , V_{DD_DMC} , V_{DD_USB} , V_{DD_HADC} , V_{DD_RTC} , $V_{DD_PCI_TX}$, $V_{DD_PCI_RX}$, and $V_{DD_PCI_CORE}$.

Table 43. Power-Up Reset Timing

Parameter	Min	Max	Unit
<i>Timing Requirement</i>			
$t_{RST_IN_PWR}$	$\overline{SYS_HWRST}$ Deasserted after $V_{DD_SUPPLIES}$ (V_{DD_INT} , V_{DD_EXT} , V_{DD_DMC} , V_{DD_USB} , V_{DD_HADC} , V_{DD_RTC} , $V_{DD_PCI_TX}$, $V_{DD_PCI_RX}$, $V_{DD_PCI_CORE}$) and SYS_CLKINx are Stable and Within Specification $11 \times t_{CKIN}$		ns

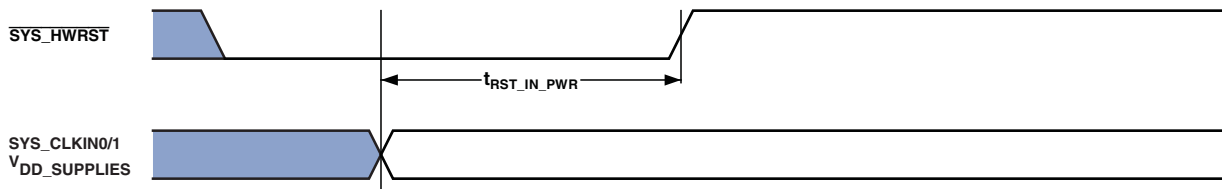

NOTE: $V_{DD_SUPPLIES}$ REFER TO V_{DD_INT} , V_{DD_EXT} , V_{DD_DMC} , V_{DD_USB} , V_{DD_HADC} , V_{DD_RTC} , $V_{DD_PCI_TX}$, $V_{DD_PCI_RX}$ AND $V_{DD_PCI_CORE}$

Figure 9. Power-Up Reset Timing

ADSP-SC582/SC583/SC584/SC587/SC589/ADSP-21583/21584/21587

Clock and Reset Timing

Table 44 and Figure 10 describe clock and reset operations related to the CGU and RCU. Per the CCLK, SYSCLK, SCLK, DCLK, and OCLK timing specifications in Table 29, combinations of SYS_CLKIN and clock multipliers must not select clock rates in excess of the maximum instruction rate of the processor.

Table 44. Clock and Reset Timing

Parameter		Min	Max	Unit
<i>Timing Requirements</i>				
f_{CKIN}	SYS_CLKINx Frequency (Crystal) ^{1, 2, 3}	20	50	MHz
	SYS_CLKINx Frequency (External CLKIN) ^{1, 2, 3}	20	50	MHz
t_{CKINL}	CLKIN Low Pulse ¹	10		ns
t_{CKINH}	CLKIN High Pulse ¹	10		ns
t_{WRST}	\overline{RESET} Asserted Pulse Width Low ⁴	$11 \times t_{CKIN}$		ns

¹ Applies to PLL bypass mode and PLL nonbypass mode.

² The t_{CKIN} period (see Figure 10) equals $1/f_{CKIN}$.

³ If the CGU_CTL.DF bit is set, the minimum f_{CKIN} specification is 40 MHz.

⁴ Applies after power-up sequence is complete. See Table 43 and Figure 9 for power-up reset timing.

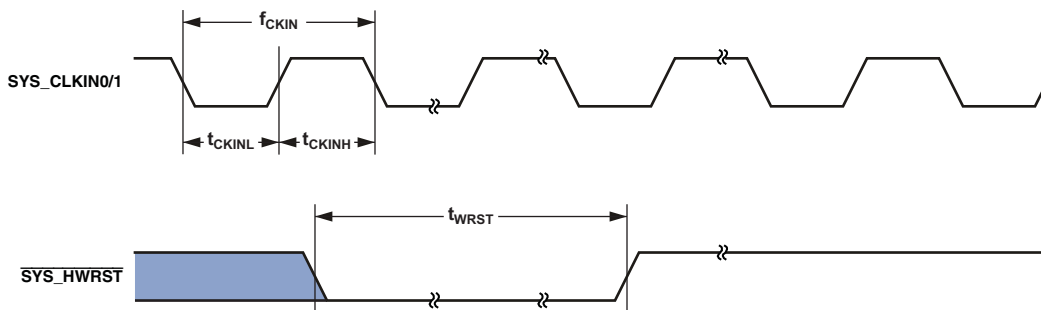

Figure 10. Clock and Reset Timing

ADSP-SC582/SC583/SC584/SC587/SC589/ADSP-21583/21584/21587

Asynchronous Read

Table 45 and Figure 11 show asynchronous memory read timing, related to the SMC.

Table 45. Asynchronous Read

Parameter	Min	Max	Unit
<i>Timing Requirements</i>			
$t_{SDATARE}$ DATA in Setup Before $\overline{SMC0_ARE}$ High	5.1		ns
$t_{HDATARE}$ DATA in Hold After $\overline{SMC0_ARE}$ High	0.7		ns
$t_{DARDYARE}$ $\overline{SMC0_ARDY}$ Valid After $\overline{SMC0_ARE}$ Low ^{1, 2}		$(RAT - 2.5) \times t_{SCLK0} - 17.5$	ns
<i>Switching Characteristics</i>			
t_{AMSARE} $\overline{SMC0_AMSx}$ Assertion Before $\overline{SMC0_ARE}$ Low ³	$(PREST + RST + PREAT) \times t_{SCLK0} - 2$		ns
t_{AOEARE} $\overline{SMC0_AOE}$ Assertion Before $\overline{SMC0_ARE}$ Low	$(RST + PREAT) \times t_{SCLK0} - 2$		ns
t_{HARE} Output ⁴ Hold After $\overline{SMC0_ARE}$ High ⁵	$RHT \times t_{SCLK0} - 2$		ns
t_{WARE} $\overline{SMC0_ARE}$ Active Low Width ⁶	$RAT \times t_{SCLK0} - 2$		ns
$t_{DAREARDY}$ $\overline{SMC0_ARE}$ High Delay After $\overline{SMC0_ARDY}$ Assertion ¹	$2.5 \times t_{SCLK0}$	$3.5 \times t_{SCLK0} + 17.5$	ns

¹ $\overline{SMC0_BxCTL.ARDYEN}$ bit = 1.

² RAT value set using the $\overline{SMC_BxTIM.RAT}$ bits.

³ PREST, RST, and PREAT values set using the $\overline{SMC_BxETIM.PREST}$ bits, $\overline{SMC_BxTIM.RST}$ bits, and the $\overline{SMC_BxETIM.PREAT}$ bits.

⁴ Output signals are $\overline{SMC0_Ax}$, $\overline{SMC0_AMS}$, $\overline{SMC0_AOE}$, $\overline{SMC0_ABEX}$.

⁵ RHT value set using the $\overline{SMC_BxTIM.RHT}$ bits.

⁶ $\overline{SMC0_BxCTL.ARDYEN}$ bit = 0.

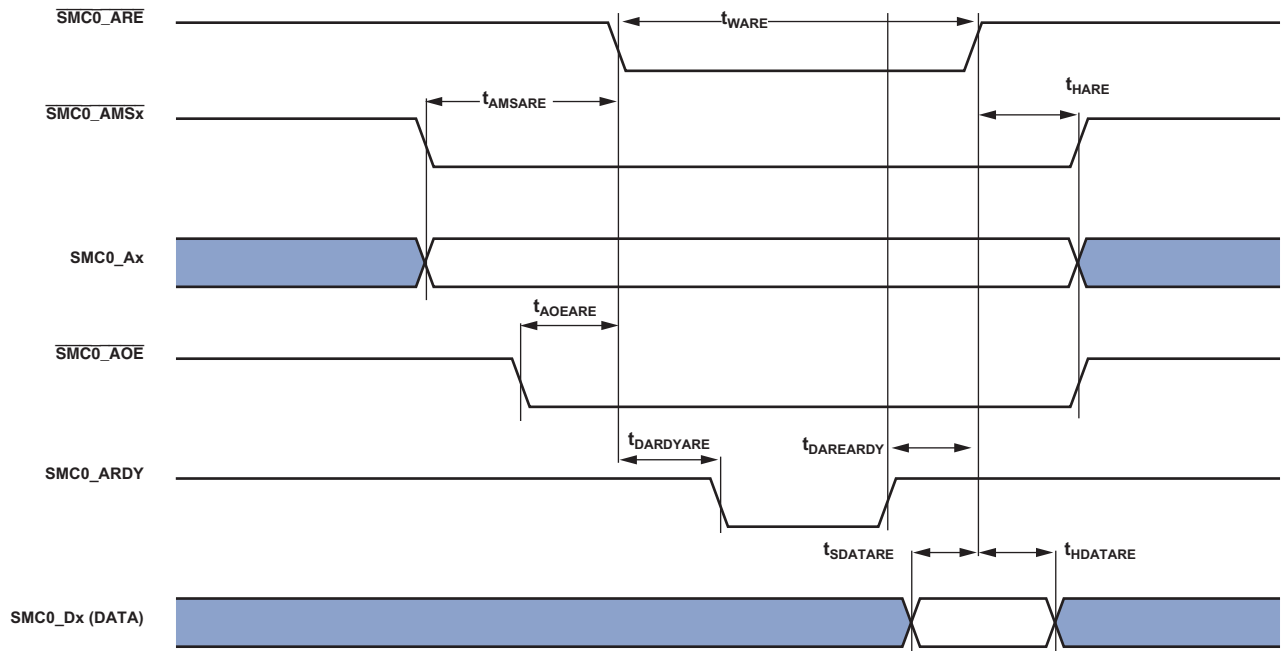

Figure 11. Asynchronous Read

ADSP-SC582/SC583/SC584/SC587/SC589/ADSP-21583/21584/21587

SMC Read Cycle Timing With Reference to SYS_CLKOUT

The following SMC specifications (Table 46 and Figure 12) with respect to SYS_CLKOUT are given to accommodate the connection of the SMC to programmable logic devices. These specifications assume that SYS_CLKOUT is outputting a buffered version of SCLK0 by setting CGU_CLKOUTSEL.CLKOUTSEL = 0x3.

Table 46. SMC Read Cycle Timing With Reference to SYS_CLKOUT (BxMODE = b#00)

Parameter	Min	Max	Unit
<i>Timing Requirements</i>			
t_{SDAT} SMC0_Dx Setup Before SYS_CLKOUT	4.3		ns
t_{HDAT} SMC0_Dx Hold After SYS_CLKOUT	5		ns
t_{SARDY} SMC0_ARDY Setup Before SYS_CLKOUT	14.4		ns
t_{HARDY} SMC0_ARDY Hold After SYS_CLKOUT	0.7		ns
<i>Switching Characteristics</i>			
t_{DO} Output Delay After SYS_CLKOUT ¹		7	ns
t_{HO} Output Hold After SYS_CLKOUT ¹	-2.5		ns

¹Output signals are SMC0_Ax, SMC0_AMSx, SMC0_AOE, and SMC0_ABEx.

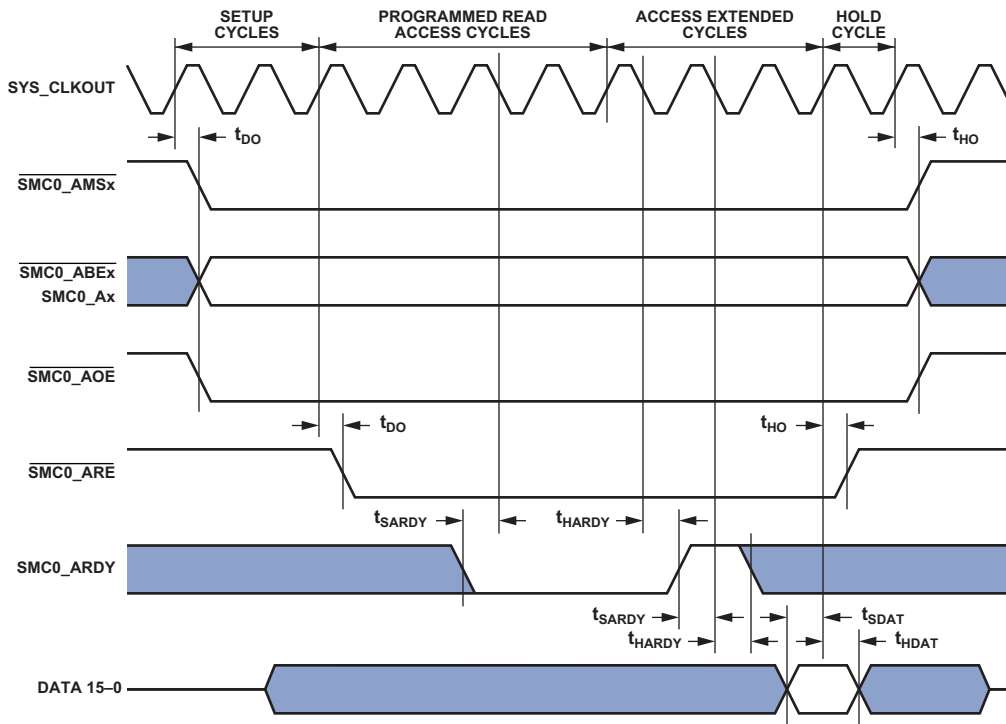

Figure 12. Asynchronous Memory Read Cycle Timing

ADSP-SC582/SC583/SC584/SC587/SC589/ADSP-21583/21584/21587

Asynchronous Flash Read

Table 47 and Figure 13 show asynchronous flash memory read timing, related to the SMC.

Table 47. Asynchronous Flash Read

Parameter		Min	Max	Unit
<i>Switching Characteristics</i>				
t_{AMSADV}	SMC0_Ax (Address)/ $\overline{SMC0_AMSx}$ Assertion Before SMC0_NORDV Low ¹	$PREST \times t_{SCLK0} - 2$		ns
t_{WADV}	SMC0_NORDV Active Low Width ²	$RST \times t_{SCLK0} - 2$		ns
$t_{DADVARE}$	$\overline{SMC0_ARE}$ Low Delay From SMC0_NORDV High ³	$PREAT \times t_{SCLK0} - 2$		ns
t_{HARE}	Output ⁴ Hold After $\overline{SMC0_ARE}$ High ⁵	$RHT \times t_{SCLK0} - 2$		ns
t_{WARE} ⁶	$\overline{SMC0_ARE}$ Active Low Width ⁷	$RAT \times t_{SCLK0} - 2$		ns

¹PREST value set using the SMC_BxETIM.PREST bits.

²RST value set using the SMC_BxTIM.RST bits.

³PREAT value set using the SMC_BxETIM.PREAT bits.

⁴Output signals are SMC0_Ax, SMC0_AMS, SMC0_AOE.

⁵RHT value set using the SMC_BxTIM.RHT bits.

⁶SMC0_BxCTL.ARDYEN bit = 0.

⁷RAT value set using the SMC_BxTIM.RAT bits.

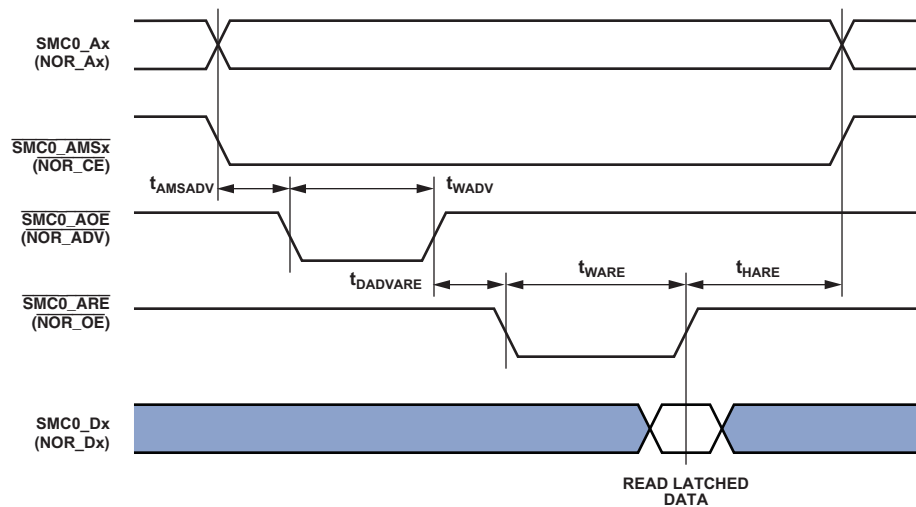

Figure 13. Asynchronous Flash Read

ADSP-SC582/SC583/SC584/SC587/SC589/ADSP-21583/21584/21587

Asynchronous Page Mode Read

Table 48 and Figure 14 show asynchronous memory page mode read timing, related to the SMC.

Table 48. Asynchronous Page Mode Read

Parameter	Min	Max	Unit
<i>Switching Characteristics</i>			
t_{AV} SMC0_Axx (Address) Valid for First Address Minimum Width ¹	$(PREST + RST + PREAT + RAT) \times t_{SCLK0} - 2$		ns
t_{AV1} SMC0_Axx (Address) Valid for Subsequent SMC0_Ax (Address) Minimum Width	$PGWS \times t_{SCLK0} - 2$		ns
t_{WADV} SMC0_NORDV Active Low Width ²	$RST \times t_{SCLK0} - 2$		ns
t_{HARE} Output ³ Hold After $\overline{SMC0_ARE}$ High ⁴	$RHT \times t_{SCLK0} - 2$		ns
t_{WARE} ⁵ $\overline{SMC0_ARE}$ Active Low Width ^{6, 7}	$(RAT + (Nw - 1) \times PGWS) \times t_{SCLK0} - 2$		ns

¹PREST, RST, PREAT and RAT values set using the SMC_BxETIM.PREST bits, SMC_BxTIM.RST bits, SMC_BxETIM.PREAT bits, and the SMC_BxTIM.RAT bits.

²RST value set using the SMC_BxTIM.RST bits.

³Output signals are SMC0_Ax, SMC0_AMSx, SMC0_AOE.

⁴RHT value set using the SMC_BxTIM.RHT bits.

⁵SMC_BxCTL.ARDYEN bit = 0.

⁶RAT value set using the SMC_BxTIM.RAT bits.

⁷Nw = Number of 16-bit data words read.

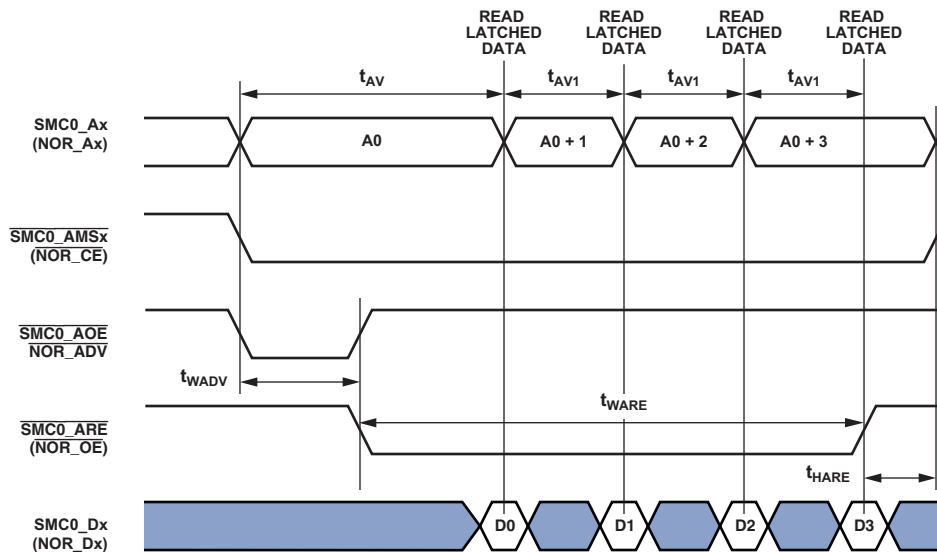

Figure 14. Asynchronous Page Mode Read

ADSP-SC582/SC583/SC584/SC587/SC589/ADSP-21583/21584/21587

Asynchronous Write

Table 49 and Figure 15 show asynchronous memory write timing, related to the SMC.

Table 49. Asynchronous Memory Write

Parameter	Min	Max	Unit
<i>Timing Requirement</i>			
$t_{DARDYAWE}^1$ SMC0_ARDY Valid After $\overline{SMC0_AWE}$ Low ²		$(WAT - 2.5) \times t_{SCLK0} - 17.5$	ns
<i>Switching Characteristics</i>			
t_{ENDAT} DATA Enable After $\overline{SMC0_AMSx}$ Assertion	-3.5		ns
t_{DDAT} DATA Disable After $\overline{SMC0_AMSx}$ Deassertion		2.5	ns
t_{AMSAWE} ADDR/ $\overline{SMC0_AMSx}$ Assertion Before $\overline{SMC0_AWE}$ Low ³	$(PREST + WST + PREAT) \times t_{SCLK0} - 2$		ns
t_{HAWE} Output ⁴ Hold After $\overline{SMC0_AWE}$ High ⁵	$WHT \times t_{SCLK0} - 3.5$		ns
t_{WAVE}^6 $\overline{SMC0_AWE}$ Active Low Width ²	$WAT \times t_{SCLK0} - 2$		ns
$t_{DAWEARDY}^1$ $\overline{SMC0_AWE}$ High Delay After SMC0_ARDY Assertion	$2.5 \times t_{SCLK0}$	$3.5 \times t_{SCLK0} + 17.5$	ns

¹SMC_BxCTL.ARDYEN bit = 1.

²WAT value set using the SMC_BxTIM.WAT bits.

³PREST, WST, PREAT values set using the SMC_BxETIM.PREST bits, SMC_BxTIM.WST bits, SMC_BxETIM.PREAT bits, and the SMC_BxTIM.RAT bits.

⁴Output signals are DATA, SMC0_Ax, $\overline{SMC0_AMSx}$, SMC0_ABE_x.

⁵WHT value set using the SMC_BxTIM.WHT bits.

⁶SMC_BxCTL.ARDYEN bit = 0.

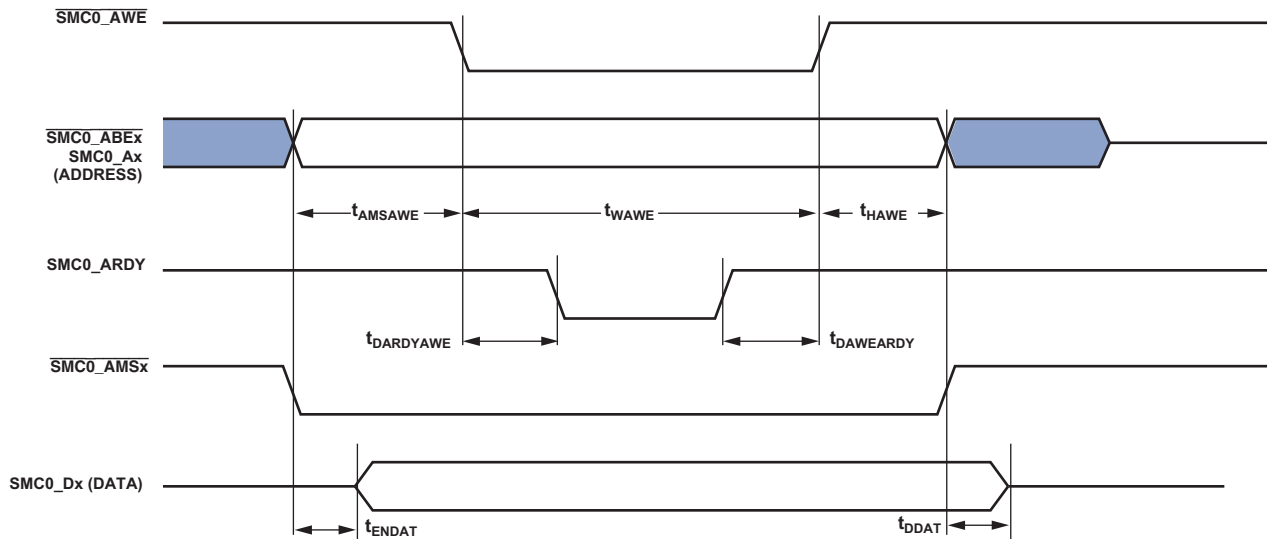

Figure 15. Asynchronous Write

ADSP-SC582/SC583/SC584/SC587/SC589/ADSP-21583/21584/21587

SMC Write Cycle Timing With Reference to SYS_CLKOUT

The following SMC specifications (Table 50 and Figure 16) with respect to SYS_CLKOUT are given to accommodate the connection of the SMC to programmable logic devices. These specifications assume that SYS_CLKOUT is outputting a buffered version of SCLK0 by setting CGU_CLKOUTSEL.CLKOUTSEL = 0x3.

Table 50. SMC Write Cycle Timing With Reference to SYS_CLKOUT (BxMODE = b#00)

Parameter		Min	Max	Unit
<i>Timing Requirements</i>				
t_{SARDY}	SMC0_ARDY Setup Before SYS_CLKOUT	14.4		ns
t_{HARDY}	SMC0_ARDY Hold After SYS_CLKOUT	0.7		ns
<i>Switching Characteristics</i>				
t_{DDAT}	SMC0_Dx Disable After SYS_CLKOUT		7	ns
t_{ENDAT}	SMC0_Dx Enable After SYS_CLKOUT	-2.5		ns
t_{DO}	Output Delay After SYS_CLKOUT ¹		7	ns
t_{HO}	Output Hold After SYS_CLKOUT ¹	-2.5		ns

¹Output pins/balls include SMC0_AMSx, SMC0_ABEx, SMC0_Ax, SMC0_Dx, SMC0_AOE, and SMC0_AWE.

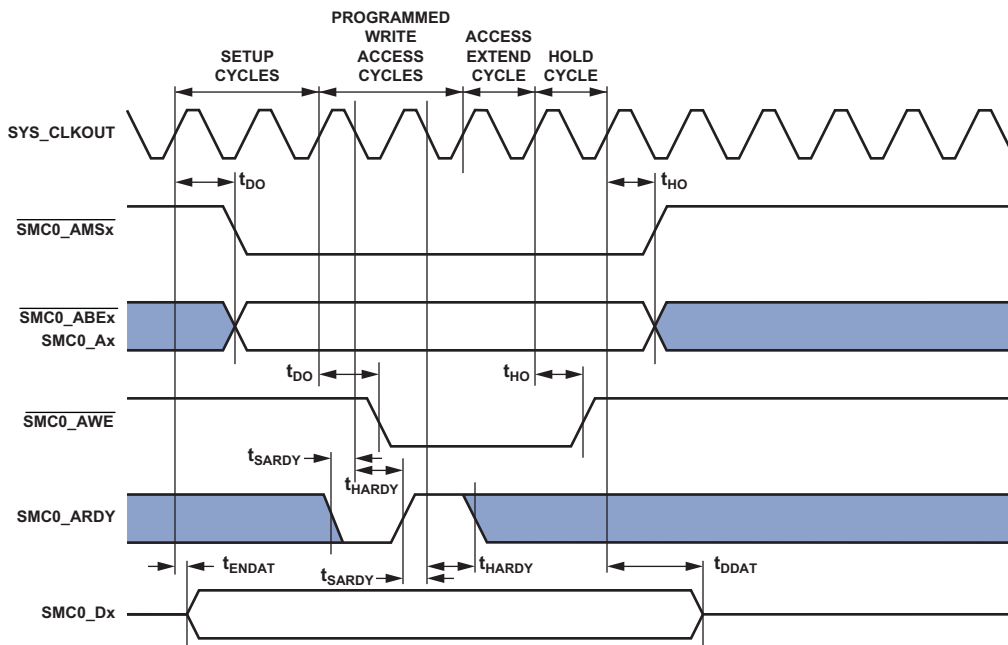

Figure 16. SMC Write Cycle Timing With Reference to SYS_CLKOUT Timing

ADSP-SC582/SC583/SC584/SC587/SC589/ADSP-21583/21584/21587

Asynchronous Flash Write

Table 51 and Figure 17 show asynchronous flash memory write timing, related to the SMC.

Table 51. Asynchronous Flash Write

Parameter		Min	Max	Unit
<i>Switching Characteristics</i>				
t_{AMSADV}	$\overline{SMC0_Ax}/\overline{SMC0_AMSx}$ Assertion Before ADV Low ¹		$PREST \times t_{SCLK0} - 2$	ns
$t_{DADVAWE}$	$\overline{SMC0_AWE}$ Low Delay From ADV High ²		$PREAT \times t_{SCLK0} - 2$	ns
t_{WADV}	$\overline{NR_ADV}$ Active Low Width ³		$WST \times t_{SCLK0} - 2$	ns
t_{HAWE}	Output ⁴ Hold After $\overline{SMC0_AWE}$ High ⁵		$WHT \times t_{SCLK0} - 3.5$	ns
t_{WAVE} ⁶	$\overline{SMC0_AWE}$ Active Low Width ⁷		$WAT \times t_{SCLK0} - 2$	ns

¹PREST value set using the SMC_BxETIM.PREST bits.

²PREAT value set using the SMC_BxETIM.PREAT bits.

³WST value set using the SMC_BxTIM.WST bits.

⁴Output signals are DATA, SMC0_Ax, SMC0_AMSx, SMC0_ABEx.

⁵WHT value set using the SMC_BxTIM.WHT bits.

⁶SMC_BxCTL.ARDYEN bit = 0.

⁷WAT value set using the SMC_BxTIM.WAT bits.

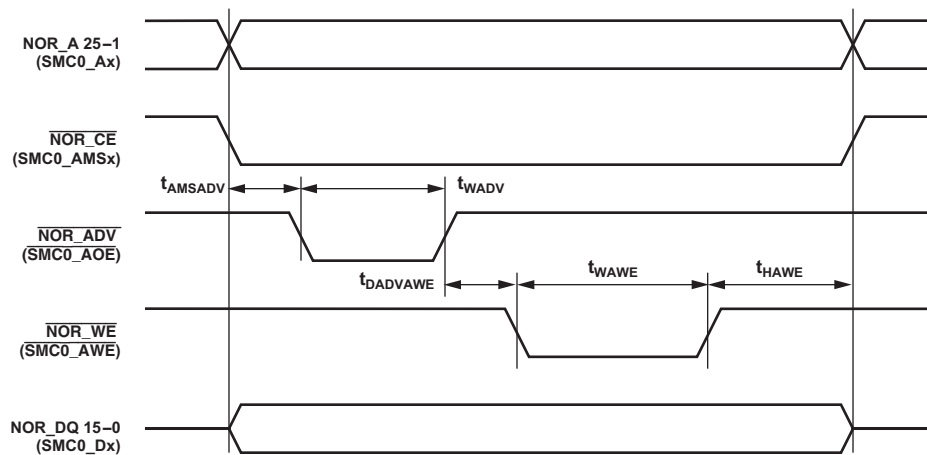

Figure 17. Asynchronous Flash Write

All Accesses

Table 52 describes timing that applies to all memory accesses, related to the SMC.

Table 52. All Accesses

Parameter		Min	Max	Unit
<i>Switching Characteristic</i>				
t_{TURN}	$\overline{SMC0_AMSx}$ Inactive Width		$(IT + TT) \times t_{SCLK0} - 2$	ns

ADSP-SC582/SC583/SC584/SC587/SC589/ADSP-21583/21584/21587

DDR2 SDRAM Clock and Control Cycle Timing

Table 53 and Figure 18 show DDR2 SDRAM clock and control cycle timing, related to the DMC.

Table 53. DDR2 SDRAM Clock and Control Cycle Timing, V_{DD_DMC} , Nominal 1.8 V¹

Parameter	400 MHz ²		Unit
	Min	Max	
<i>Switching Characteristics</i>			
t_{CK}	Clock Cycle Time (CL = 2 Not Supported)		ns
$t_{CH(ABS)}^3$	Minimum Clock Pulse Width		t_{CK}
$t_{CL(ABS)}^3$	Maximum Clock Pulse Width		t_{CK}
t_{IS}	Control/Address Setup Relative to DMCx_CK Rise		ps
t_{IH}	Control/Address Hold Relative to DMCx_CK Rise		ps

¹Specifications apply to both DMC0 and DMC1.

²In order to ensure proper operation of the DDR2, all the DDR2 requirements must be strictly followed. See [Interfacing DDR3/DDR2/LPDDR Memory to ADSP-SC5xx/215xx Processors \(EE-387\)](#).

³As per JESD79-2E definition.

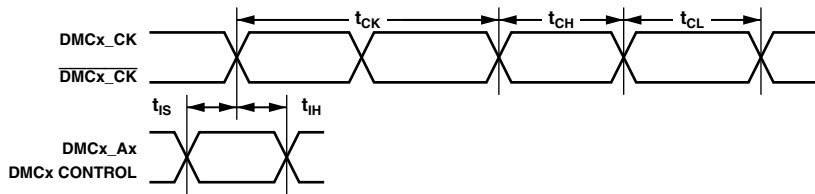

NOTE: CONTROL = DMCx_CS0, DMCx_CKE, DMCx_RAS, DMCx_CAS, AND DMCx_WE.
ADDRESS = DMCx_A0-A15 AND DMCx_BA0-BA2.

Figure 18. DDR2 SDRAM Clock and Control Cycle Timing

ADSP-SC582/SC583/SC584/SC587/SC589/ADSP-21583/21584/21587

DDR2 SDRAM Read Cycle Timing

Table 54 and Figure 19 show DDR2 SDRAM read cycle timing, related to the DMC.

Table 54. DDR2 SDRAM Read Cycle Timing, V_{DD_DMC} , Nominal 1.8 V¹

Parameter		400 MHz ²		Unit
		Min	Max	
<i>Timing Requirements</i>				
t_{DQSQ}	DMCx_DQS to DMCx_DQ Skew for DMCx_DQS and Associated DMCx_DQxx Signals		0.2	ns
t_{QH}	DMCx_DQxx, DMCx_DQS Output Hold Time From DMCx_DQS	0.8		ns
t_{RPRE}	Read Preamble	0.9		t_{CK}
t_{RPST}	Read Postamble	0.4		t_{CK}

¹Specifications apply to both DMC0 and DMC1.

²In order to ensure proper operation of the DDR2, all the DDR2 requirements must be strictly followed. See [Interfacing DDR3/DDR2/LPDDR Memory to ADSP-SC5xx/215xx Processors \(EE-387\)](#).

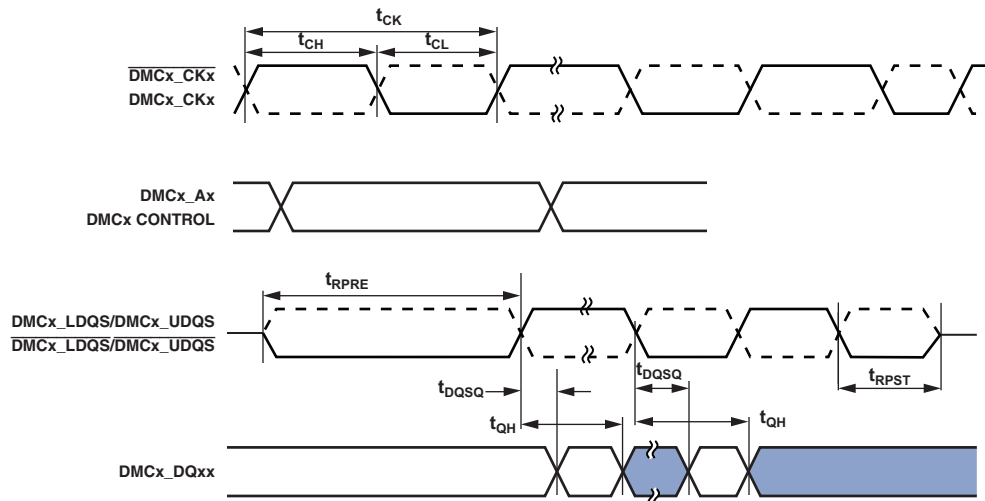

NOTE: CONTROL = DMCx_CS0, DMCx_CKE, DMCx_RAS, DMCx_CAS, AND DMCx_WE.
ADDRESS = DMCx_A00-13 AND DMCx_BA0-1.

Figure 19. DDR2 SDRAM Controller Input AC Timing

ADSP-SC582/SC583/SC584/SC587/SC589/ADSP-21583/21584/21587

DDR2 SDRAM Write Cycle Timing

Table 55 and Figure 20 show DDR2 SDRAM write cycle timing, related to the DMC.

Table 55. DDR2 SDRAM Write Cycle Timing, V_{DD_DMC} , Nominal 1.8 V¹

Parameter	400 MHz ²		Unit
	Min	Max	
<i>Switching Characteristics</i>			
t _{DQSS}	DMCx_DQS Latching Rising Transitions to Associated Clock Edges ³		t _{CK}
t _{DS}	Last Data Valid to DMCx_DQS Delay		ns
t _{DH}	DMCx_DQS to First Data Invalid Delay		ns
t _{DSS}	DMCx_DQS Falling Edge to Clock Setup Time		t _{CK}
t _{DSH}	DMCx_DQS Falling Edge Hold Time From DMCx_CK		t _{CK}
t _{DQSH}	DMCx_DQS Input High Pulse Width		t _{CK}
t _{DQSL}	DMCx_DQS Input Low Pulse Width		t _{CK}
t _{WPRE}	Write Preamble		t _{CK}
t _{WPST}	Write Postamble		t _{CK}
t _{IPW}	Address and Control Output Pulse Width		t _{CK}
t _{DIPW}	DMCx_DQ and DMCx_DM Output Pulse Width		t _{CK}

¹Specifications apply to both DMC0 and DMC1.

²To ensure proper operation of the DDR2, all the DDR2 requirements must be strictly followed. See [Interfacing DDR3/DDR2/LPDDR Memory to ADSP-SC5xx/215xx Processors \(EE-387\)](#).

³Write command to first DMCx_DQS delay = $WL \times t_{CK} + t_{DQSS}$.

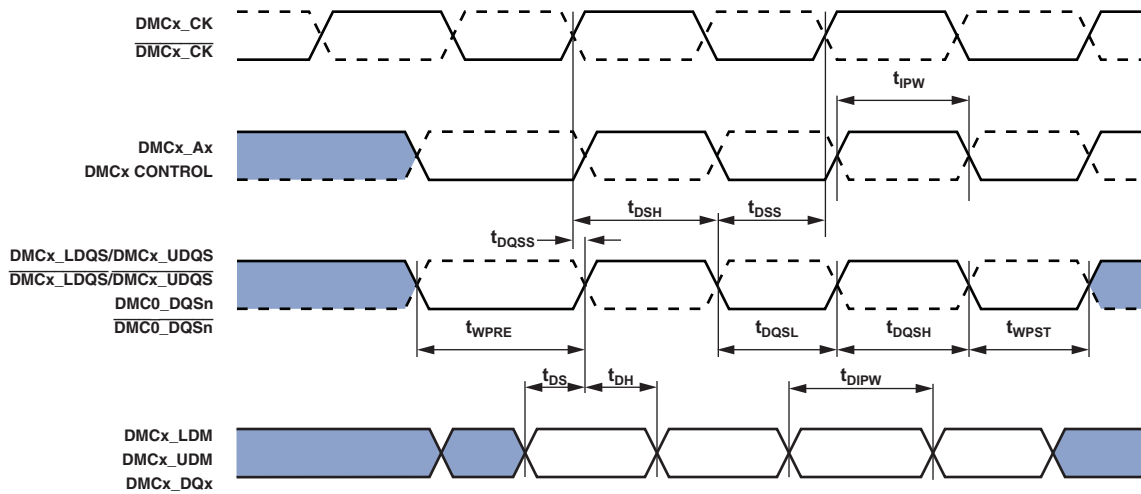

NOTE: CONTROL = DMCx_CS0, DMCx_CKE, DMCx_RAS, DMCx_CAS, AND DMCx_WE.
ADDRESS = DMCx_A00-13 AND DMCx_BA0-1.

Figure 20. DDR2 SDRAM Controller Output AC Timing

ADSP-SC582/SC583/SC584/SC587/SC589/ADSP-21583/21584/21587

Mobile DDR (LPDDR) SDRAM Clock and Control Cycle Timing

Table 56 and Figure 21 show mobile DDR SDRAM clock and control cycle timing, related to the DMC.

Table 56. Mobile DDR SDRAM Clock and Control Cycle Timing, V_{DD_DMC} Nominal 1.8 V¹

Parameter	200 MHz ²		Unit
	Min	Max	
<i>Switching Characteristics</i>			
t_{CK}	Clock Cycle Time (CL = 2 Not Supported)		ns
t_{CH}	Minimum Clock Pulse Width		t_{CK}
t_{CL}	Maximum Clock Pulse Width		t_{CK}
t_{IS}	Control/Address Setup Relative to DMCx_CK Rise		ns
t_{IH}	Control/Address Hold Relative to DMCx_CK Rise		ns

¹Specifications apply to both DMC0 and DMC1.

²To ensure proper operation of LPDDR, all the LPDDR requirements must be strictly followed. See [Interfacing DDR3/DDR2/LPDDR Memory to ADSP-SC5xx/215xx Processors \(EE-387\)](#).

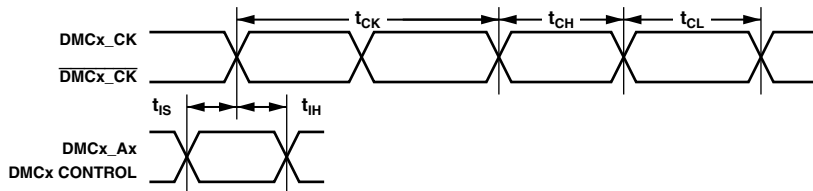

NOTE: CONTROL = DMCx_CS0, DMCx_CKE, DMCx_RAS, DMCx_CAS, AND DMCx_WE.
ADDRESS = DMCx_A0-A15 AND DMCx_BA0-BA2.

Figure 21. Mobile DDR SDRAM Clock and Control Cycle Timing

ADSP-SC582/SC583/SC584/SC587/SC589/ADSP-21583/21584/21587

Mobile DDR SDRAM Read Cycle Timing

Table 57 and Figure 22 show mobile DDR SDRAM read cycle timing, related to the DMC.

Table 57. Mobile DDR SDRAM Read Cycle Timing, V_{DD_DMC} Nominal 1.8 V¹

Parameter		200 MHz ²		Unit
		Min	Max	
<i>Timing Requirements</i>				
t_{QH}	DMCx_DQ, DMCx_DQS Output Hold Time From DMCx_DQS	1.75		ns
t_{DQSQ}	DMCx_DQS to DMCx_DQ Skew for DMCx_DQS and Associated DMCx_DQ Signals		0.4	ns
t_{RPRE}	Read Preamble	0.9	1.1	t_{CK}
t_{RPST}	Read Postamble	0.4	0.6	t_{CK}

¹Specifications apply to both DMC0 and DMC1.

²To ensure proper operation of LPDDR, all the LPDDR requirements must be strictly followed. See [Interfacing DDR3/DDR2/LPDDR Memory to ADSP-SC5xx/215xx Processors \(EE-387\)](#).

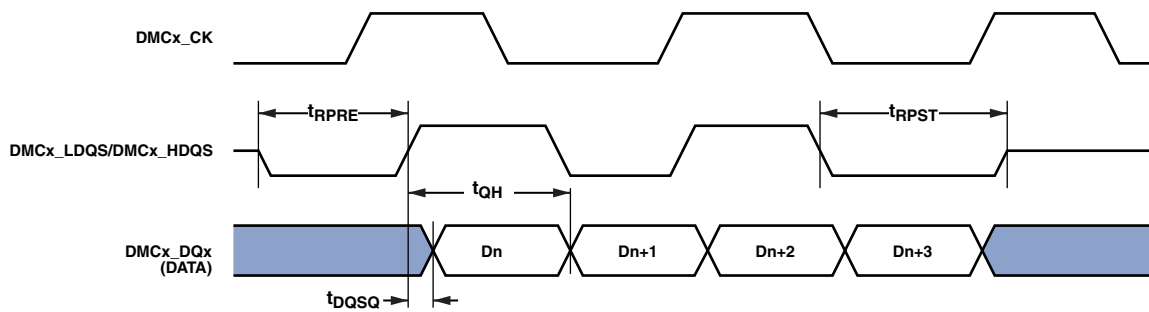

Figure 22. Mobile DDR SDRAM Controller Input AC Timing

ADSP-SC582/SC583/SC584/SC587/SC589/ADSP-21583/21584/21587

Mobile DDR SDRAM Write Cycle Timing

Table 58 and Figure 23 show mobile DDR SDRAM write cycle timing, related to the DMC.

Table 58. Mobile DDR SDRAM Write Cycle Timing, V_{DD_DMC} , Nominal 1.8 V¹

Parameter		200 MHz ²		Unit
		Min	Max	
<i>Switching Characteristics</i>				
t_{DQSS} ³	DMCx_DQS Latching Rising Transitions to Associated Clock Edges	0.75	1.25	t_{CK}
t_{DS}	Last Data Valid to DMCx_DQS Delay (Slew > 1 V/ns)	0.48		ns
t_{DH}	DMCx_DQS to First Data Invalid Delay (Slew > 1 V/ns)	0.48		ns
t_{DSS}	DMCx_DQS Falling Edge to Clock Setup Time	0.2		t_{CK}
t_{DSH}	DMCx_DQS Falling Edge Hold Time From DMCx_CK	0.2		t_{CK}
t_{DQSH}	DMCx_DQS Input High Pulse Width	0.4		t_{CK}
t_{DQSL}	DMCx_DQS Input Low Pulse Width	0.4		t_{CK}
t_{WPRE}	Write Preamble	0.25		t_{CK}
t_{WPST}	Write Postamble	0.4		t_{CK}
t_{IPW}	Address and Control Output Pulse Width	2.3		ns
t_{DIPW}	DMCx_DQ and DMCx_DM Output Pulse Width	1.8		ns

¹Specifications apply to both DMC0 and DMC1.

²To ensure proper operation of LPDDR, all the LPDDR requirements must be strictly followed. See [Interfacing DDR3/DDR2/LPDDR Memory to ADSP-SC5xx/215xx Processors \(EE-387\)](#).

³Write command to first DMCx_DQS delay = $WL \times t_{CK} + t_{DQSS}$.

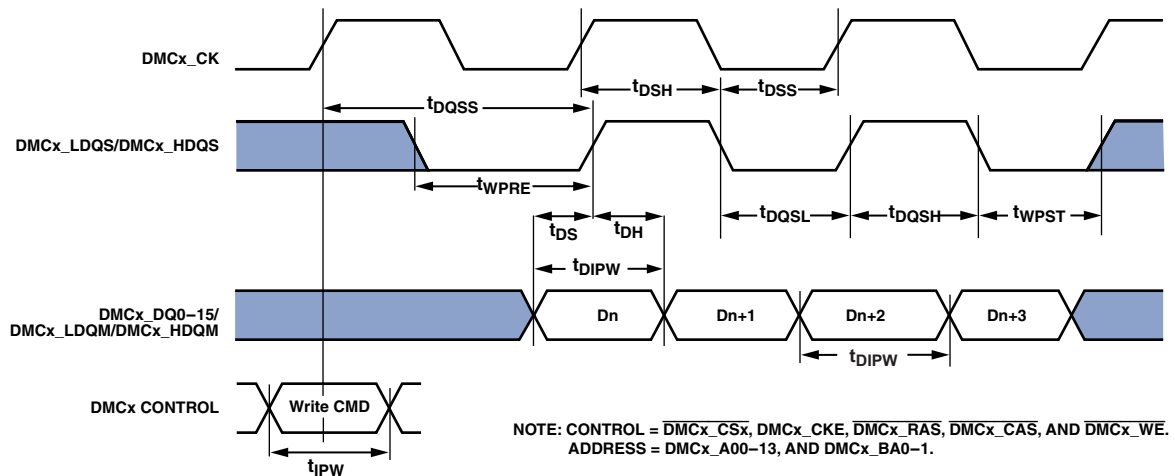

Figure 23. Mobile DDR SDRAM Controller Output AC Timing

ADSP-SC582/SC583/SC584/SC587/SC589/ADSP-21583/21584/21587

DDR3 SDRAM Clock and Control Cycle Timing

Table 59 and Figure 24 show mobile DDR3 SDRAM clock and control cycle timing, related to the DMC.

Table 59. DDR3 SDRAM Clock and Control Cycle Timing, V_{DD_DMC} , Nominal 1.5 V¹

Parameter	450 MHz ²		Unit
	Min	Max	
<i>Switching Characteristics</i>			
t_{CK}	Clock Cycle Time (CL = 2 Not Supported)		ns
$t_{CH(abs)}^3$	Minimum Clock Pulse Width		t_{CK}
$t_{CL(abs)}^3$	Maximum Clock Pulse Width		t_{CK}
t_{IS}	Control/Address Setup Relative to DMCx_CK Rise		ns
t_{IH}	Control/Address Hold Relative to DMCx_CK Rise		ns

¹Specifications apply to both DMC0 and DMC1.

²To ensure proper operation of the DDR3, all the DDR3 requirements must be strictly followed. See [Interfacing DDR3/DDR2/LPDDR Memory to ADSP-SC5xx/215xx Processors \(EE-387\)](#).

³As per JESD79-3F definition.

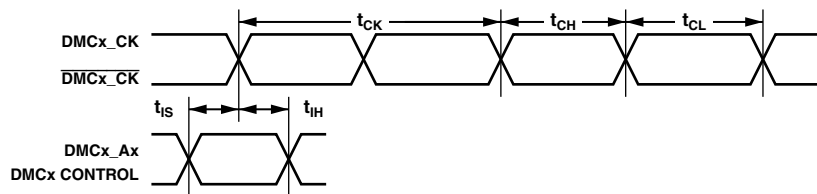

NOTE: CONTROL = DMCx_CS0, DMCx_CKE, DMCx_RAS, DMCx_CAS, AND DMCx_WE.
ADDRESS = DMCx_A0-A15 AND DMCx_BA0-BA2.

Figure 24. DDR3 SDRAM Clock and Control Cycle Timing

ADSP-SC582/SC583/SC584/SC587/SC589/ADSP-21583/21584/21587

DDR3 SDRAM Read Cycle Timing

Table 60 and Figure 25 show mobile DDR3 SDRAM read cycle timing, related to the DMC.

Table 60. DDR3 SDRAM Read Cycle Timing, V_{DD_DMC} , Nominal 1.5 V¹

Parameter	450 MHz ²		Unit
	Min	Max	
<i>Timing Requirements</i>			
t_{DQSQ}	0.15		ns
t_{QH}	0.38		t_{CK}
t_{RPRE}	0.9		t_{CK}
t_{RPST}	0.3		t_{CK}

¹Specifications apply to both DMC0 and DMC1.

²To ensure proper operation of the DDR3, all the DDR3 requirements must be strictly followed. See [Interfacing DDR3/DDR2/LPDDR Memory to ADSP-SC5xx/215xx Processors \(EE-387\)](#).

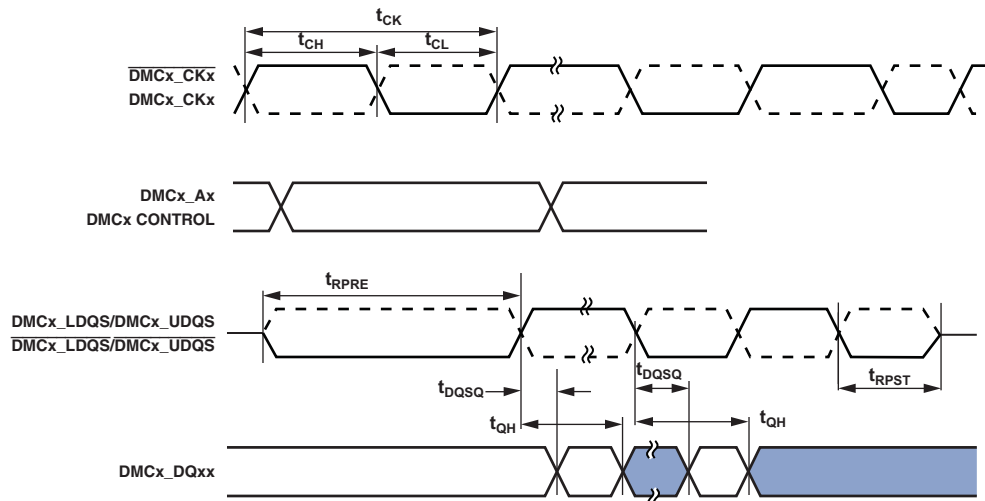

NOTE: CONTROL = DMCx_CS0, DMCx_CKE, DMCx_RAS, DMCx_CAS, AND DMCx_WE.
ADDRESS = DMCx_A00-13 AND DMCx_BA0-1.

Figure 25. DDR3 SDRAM Controller Input AC Timing

ADSP-SC582/SC583/SC584/SC587/SC589/ADSP-21583/21584/21587

DDR3 SDRAM Write Cycle Timing

Table 61 and Figure 26 show mobile DDR3 SDRAM output ac timing, related to the DMC.

Table 61. DDR3 SDRAM Write Cycle Timing, V_{DD_DMC} , Nominal 1.5 V¹

Parameter		450 MHz ²		Unit
		Min	Max	
<i>Switching Characteristics</i>				
t _{DQSS}	DMCx_DQS Latching Rising Transitions to Associated Clock Edges ³	-0.25	0.25	t _{CK}
t _{DS}	Last Data Valid to DMCx_DQS Delay (Slew > 1 V/ns)	0.125		ns
t _{DH}	DMCx_DQS to First Data Invalid Delay (Slew > 1 V/ns)	0.150		ns
t _{DSS}	DMCx_DQS Falling Edge to Clock Setup Time	0.2		t _{CK}
t _{DSH}	DMCx_DQS Falling Edge Hold Time From DMCx_CK	0.2		t _{CK}
t _{DQSH}	DMCx_DQS Input High Pulse Width	0.45	0.55	t _{CK}
t _{DQSL}	DMCx_DQS Input Low Pulse Width	0.45	0.55	t _{CK}
t _{WPRE}	Write Preamble	0.9		t _{CK}
t _{WPST}	Write Postamble	0.3		t _{CK}
t _{IPW}	Address and Control Output Pulse Width	0.840		ns
t _{DIPW}	DMCx_DQ and DMCx_DM Output Pulse Width	0.550		ns

¹Specifications apply to both DMC0 and DMC1.

²To ensure proper operation of the DDR3, all the DDR3 requirements must be strictly followed. See [Interfacing DDR3/DDR2/LPDDR Memory to ADSP-SC5xx/215xx Processors \(EE-387\)](#).

³Write command to first DMCx_DQS delay = $WL \times t_{CK} + t_{DQSS}$.

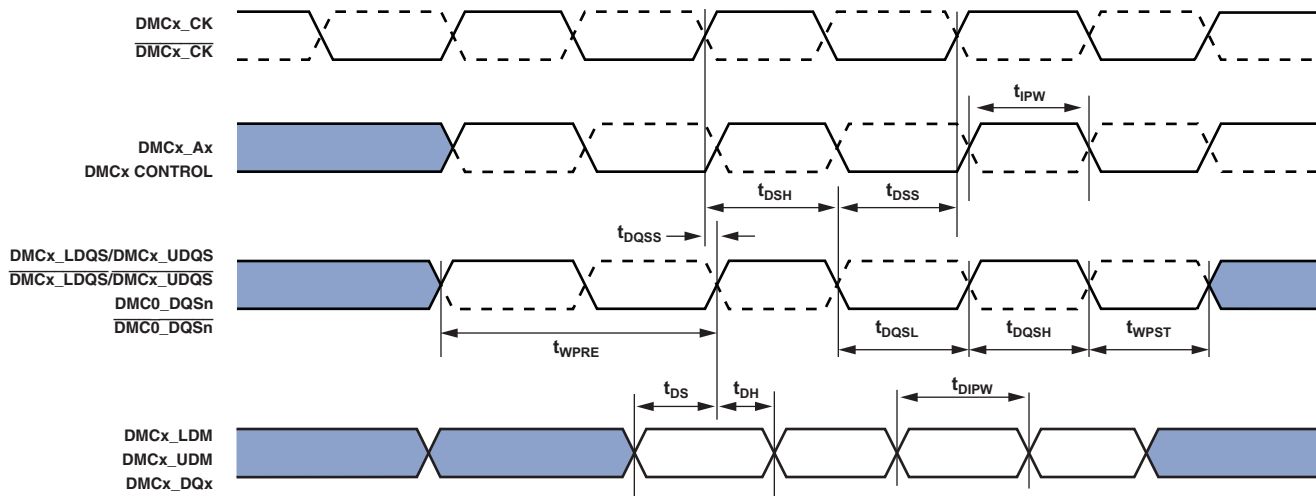

NOTE: CONTROL = $\overline{DMCx_CS0}$, $\overline{DMCx_CKE}$, $\overline{DMCx_RAS}$, $\overline{DMCx_CAS}$, AND $\overline{DMCx_WE}$.
ADDRESS = $\overline{DMCx_A00-13}$, AND $\overline{DMCx_BA0-1}$.

Figure 26. DDR3 SDRAM Controller Output AC Timing

ADSP-SC582/SC583/SC584/SC587/SC589/ADSP-21583/21584/21587

Enhanced Parallel Peripheral Interface (EPPI) Timing

Table 62 and Table 63 and Figure 27 through Figure 35 describe enhanced parallel peripheral interface (EPPI) timing operations. In Figure 27 through Figure 35, POLC[1:0] represents the setting of the EPPI_CTL register, which sets the sampling/driving edges of the EPPI clock.

When internally generated, the programmed PPI clock ($f_{PCLKPROG}$) frequency in MHz is set by the following equation where VALUE is a field in the EPPI_CLKDIV register that can be set from 0 to 65,535:

$$f_{PCLKPROG} = \frac{f_{SCLK0}}{(VALUE + 1)}$$

$$t_{PCLKPROG} = \frac{1}{f_{PCLKPROG}}$$

When externally generated, the EPPI_CLK is called $f_{PCLKEXT}$:

$$t_{PCLKEXT} = \frac{1}{f_{PCLKEXT}}$$

Table 62. Enhanced Parallel Peripheral Interface (EPPI)—Internal Clock

Parameter		Min	Max	Unit
<i>Timing Requirements</i>				
t_{SFSPi}	External FS Setup Before EPPI_CLK	6.5		ns
t_{HFSPi}	External FS Hold After EPPI_CLK	0		ns
t_{SDRPI}	Receive Data Setup Before EPPI_CLK	6.5		ns
t_{HDRPI}	Receive Data Hold After EPPI_CLK	0		ns
t_{SFS3GI}	External FS3 Input Setup Before EPPI_CLK Fall Edge in Clock Gating Mode	14		ns
t_{HFS3GI}	External FS3 Input Hold Before EPPI_CLK Fall Edge in Clock Gating Mode	0		ns
<i>Switching Characteristics</i>				
t_{PCLKW}	EPPI_CLK Width ¹	$0.5 \times t_{PCLKPROG} - 1.5$		ns
t_{PCLK}	EPPI_CLK Period ¹	$t_{PCLKPROG} - 1.5$		ns
t_{DFSPi}	Internal FS Delay After EPPI_CLK		3.5	ns
t_{HOFSPi}	Internal FS Hold After EPPI_CLK	-0.5		ns
t_{DDTPI}	Transmit Data Delay After EPPI_CLK		3.5	ns
t_{HDTPI}	Transmit Data Hold After EPPI_CLK	-0.5		ns

¹ See Table 29 for details on the minimum period that can be programmed for $t_{PCLKPROG}$.

ADSP-SC582/SC583/SC584/SC587/SC589/ADSP-21583/21584/21587

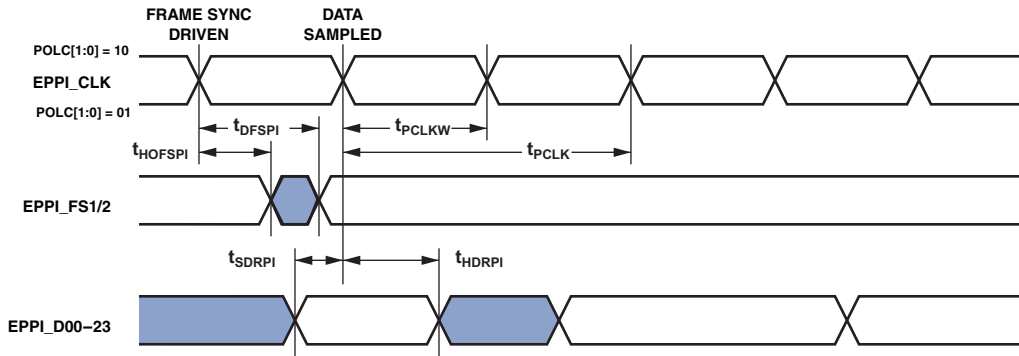

Figure 27. EPPI Internal Clock GP Receive Mode with Internal Frame Sync Timing

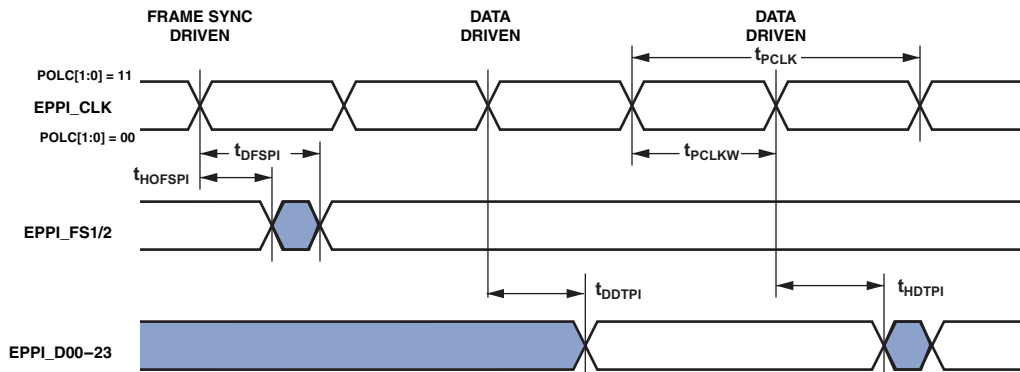

Figure 28. EPPI Internal Clock GP Transmit Mode with Internal Frame Sync Timing

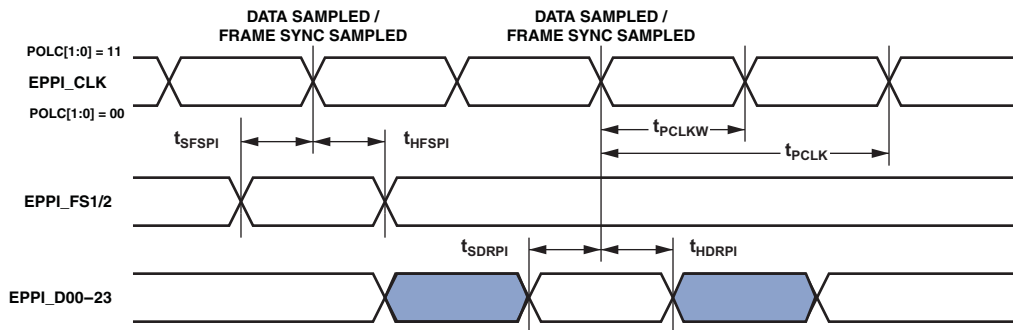

Figure 29. EPPI Internal Clock GP Receive Mode with External Frame Sync Timing

ADSP-SC582/SC583/SC584/SC587/SC589/ADSP-21583/21584/21587

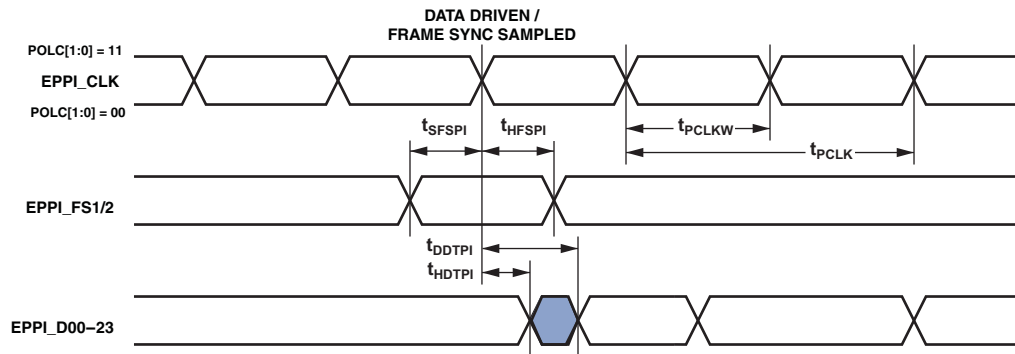

Figure 30. EPPI Internal Clock GP Transmit Mode with External Frame Sync Timing

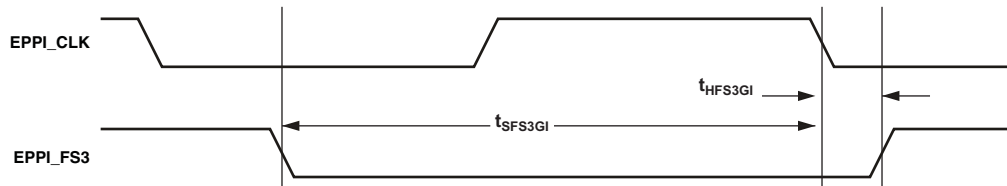

Figure 31. Clock Gating Mode with Internal Clock and External Frame Sync Timing

Table 63. Enhanced Parallel Peripheral Interface (EPPI)—External Clock

Parameter	Min	Max	Unit
<i>Timing Requirements</i>			
t_{PCLKW} EPPI_CLK Width ¹	$0.5 \times t_{PCLKEXT} - 0.5$		ns
t_{PCLK} EPPI_CLK Period ¹	$t_{PCLKEXT} - 1$		ns
t_{SFSPe} External FS Setup Before EPPI_CLK	2		ns
t_{HFSPe} External FS Hold After EPPI_CLK	3.7		ns
t_{SDRPe} Receive Data Setup Before EPPI_CLK	2		ns
t_{HDRPe} Receive Data Hold After EPPI_CLK	3.7		ns
<i>Switching Characteristics</i>			
t_{DFSPe} Internal FS Delay After EPPI_CLK		15.3	ns
t_{HOFSPe} Internal FS Hold After EPPI_CLK	2.4		ns
t_{DDTPe} Transmit Data Delay After EPPI_CLK		15.3	ns
t_{HDTPe} Transmit Data Hold After EPPI_CLK	2.4		ns

¹This specification indicates the minimum instantaneous width or period that can be tolerated due to duty cycle variation or jitter on the external EPPI_CLK. For the external EPPI_CLK ideal maximum frequency see the $f_{PCLKEXT}$ specification in Table 29.

ADSP-SC582/SC583/SC584/SC587/SC589/ADSP-21583/21584/21587

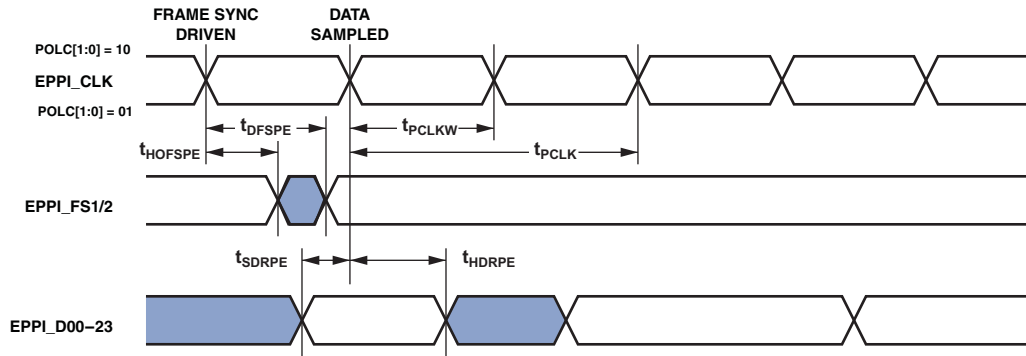

Figure 32. EPPI External Clock GP Receive Mode with Internal Frame Sync Timing

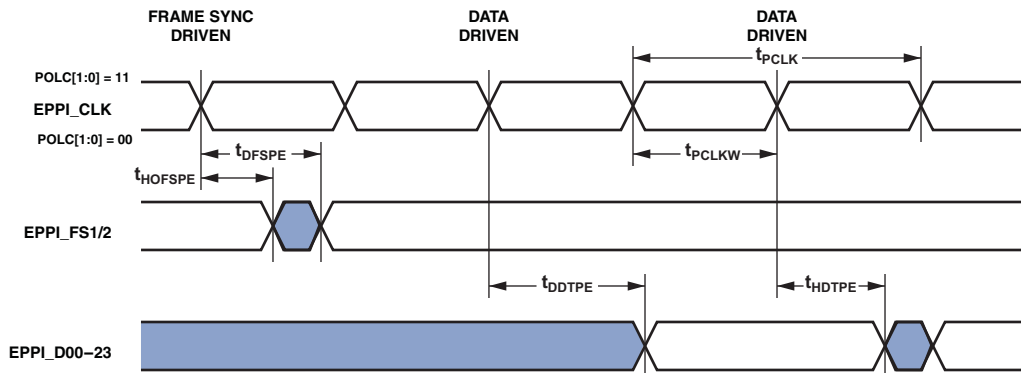

Figure 33. EPPI External Clock GP Transmit Mode with Internal Frame Sync Timing

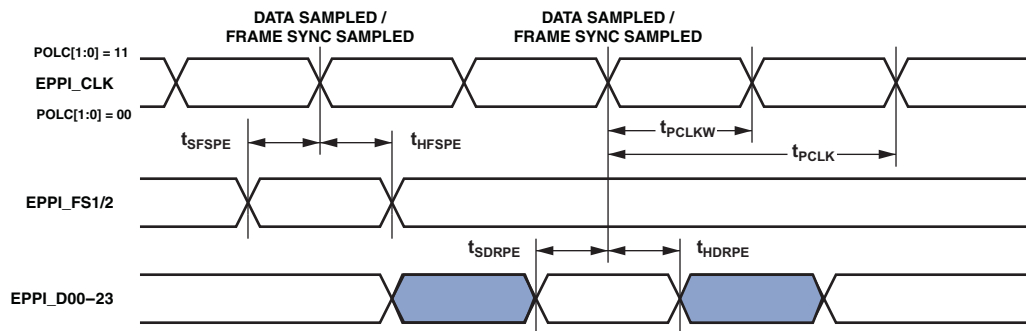

Figure 34. EPPI External Clock GP Receive Mode with External Frame Sync Timing

ADSP-SC582/SC583/SC584/SC587/SC589/ADSP-21583/21584/21587

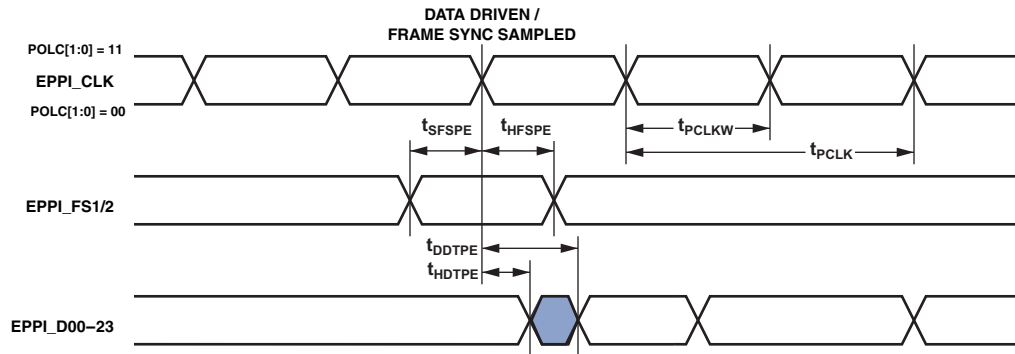

Figure 35. EPPI External Clock GP Transmit Mode with External Frame Sync Timing

ADSP-SC582/SC583/SC584/SC587/SC589/ADSP-21583/21584/21587

Link Ports (LP)

In LP receive mode, the link port clock is supplied externally and is called $f_{LCLKREXT}$, therefore the period can be represented by:

$$t_{LCLKREXT} = \frac{1}{f_{LCLKREXT}}$$

In link port transmit mode, the programmed link port clock ($f_{LCLKTPROG}$) frequency in MHz is set by the following equation where VALUE is a field in the LP_DIV register that can be set from 1 to 255:

$$f_{LCLKTPROG} = \frac{f_{CLK08}}{(VALUE \times 2)}$$

In the case where VALUE = 0, $f_{LCLKTPROG} = f_{CLK08}$. For all settings of VALUE, the following equation is true:

$$t_{LCLKTPROG} = \frac{1}{f_{LCLKTPROG}}$$

Calculation of the link receiver data setup and hold relative to the link clock is required to determine the maximum allowable skew that can be introduced in the transmission path length difference between LPx_Dx and LPx_CLK. Setup skew is the maximum delay that can be introduced in LPx_Dx relative to LPx_CLK (setup skew = $t_{LCLKTWH} \min - t_{DLDC} - t_{SLDCL}$). Hold skew is the maximum delay that can be introduced in LPx_CLK relative to LPx_Dx (hold skew = $t_{LCLKTWH} \min - t_{HLDCH} - t_{HLDCL}$).

Table 64. Link Ports—Receive¹

Parameter	Min	Max	Unit
<i>Timing Requirements</i>			
$f_{LCLKREXT}$ LPx_CLK Frequency		150	MHz
t_{SLDCL} Data Setup Before LPx_CLK Low	0.9		ns
t_{HLDCL} Data Hold After LPx_CLK Low	1.4		ns
t_{LCLKEW} LPx_CLK Period ²	$t_{LCLKREXT} - 0.42$		ns
$t_{LCLKRWL}$ LPx_CLK Width Low ²	$0.5 \times t_{LCLKREXT}$		ns
$t_{LCLKRWH}$ LPx_CLK Width High ²	$0.5 \times t_{LCLKREXT}$		ns
<i>Switching Characteristic</i>			
t_{DLALC} LPx_ACK Low Delay After LPx_CLK Low ³	$1.5 \times t_{CLK08} + 4$	$2.5 \times t_{CLK08} + 12$	ns

¹Specifications apply to LP0 and LP1.

²This specification indicates the minimum instantaneous width or period that can be tolerated due to duty cycle variation or jitter on the external LPx_CLK. For the external LPx_CLK ideal maximum frequency see the $f_{LCLKREXT}$ specification in Table 29.

³LPx_ACK goes low with t_{DLALC} relative to rise of LPx_CLK after first byte, but does not go low if the link buffer of the receiver is not about to fill.

ADSP-SC582/SC583/SC584/SC587/SC589/ADSP-21583/21584/21587

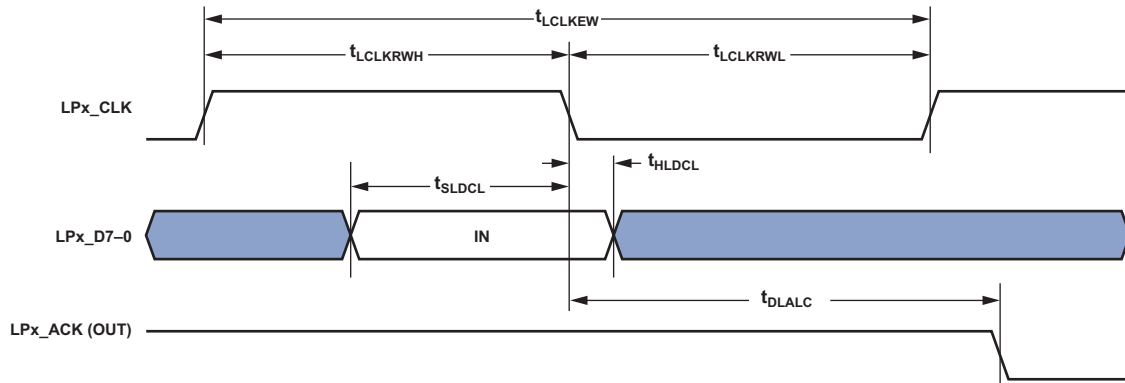

Figure 36. Link Ports—Receive

ADSP-SC582/SC583/SC584/SC587/SC589/ADSP-21583/21584/21587

Table 65. Link Ports—Transmit¹

Parameter		Min	Max	Unit
<i>Timing Requirements</i>				
t_{SLACH}	LPx_ACK Setup Before LPx_CLK Low	$2 \times t_{CLKO8} + 13.5$		ns
t_{HLACH}	LPx_ACK Hold After LPx_CLK Low	-5.5		ns
<i>Switching Characteristics</i>				
t_{DLDCH}	Data Delay After LPx_CLK High		1.6	ns
t_{HLDCH}	Data Hold After LPx_CLK High	-0.8		ns
$t_{LCLKTWL}^2$	LPx_CLK Width Low	$0.33 \times t_{LCLKTPROG}$	$0.6 \times t_{LCLKTPROG}$	ns
$t_{LCLKTWH}^2$	LPx_CLK Width High	$0.45 \times t_{LCLKTPROG}$	$0.66 \times t_{LCLKTPROG}$	ns
t_{LCLKTW}^2	LPx_CLK Period	$N \times t_{LCLKTPROG} - 0.5$		ns
t_{DLACK}	LPx_CLK Low Delay After LPx_ACK High	$t_{CLKO8} + 4$	$2 \times t_{CLKO8} + 1 \times t_{LPCLK} + 10$	ns

¹Specifications apply to LP0 and LP1.

²See Table 29 for details on the minimum period that can be programmed for $t_{LCLKTPROG}$.

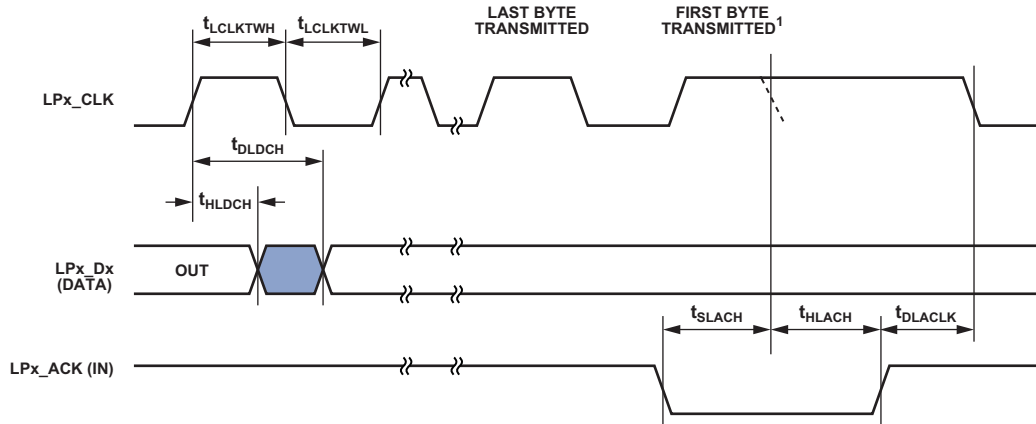

NOTES

The t_{SLACH} and t_{HLACH} specifications apply only to the LPx_CLK falling edge. If these specifications are met, LPx_CLK would extend and the dotted LPx_CLK falling edge would not occur as shown. The position of the dotted falling edge can be calculated using the $t_{LCLKTWH}$ specification. $t_{LCLKTWH}$ Min should be used for t_{SLACH} and $t_{LCLKTWL}$ Max for t_{HLACH} .

Figure 37. Link Ports—Transmit

ADSP-SC582/SC583/SC584/SC587/SC589/ADSP-21583/21584/21587

Serial Ports (SPORT)

To determine whether a device is compatible with the SPORT at clock speed n , the following specifications must be confirmed: frame sync delay and frame sync setup and hold; data delay and data setup and hold; and serial clock (SPTx_CLK) width. In [Figure 38](#), either the rising edge or the falling edge of SPTx_CLK (external or internal) can be used as the active sampling edge.

When externally generated, the SPORT clock is called $f_{SPTCLKEXT}$:

$$t_{SPTCLKEXT} = \frac{1}{f_{SPTCLKEXT}}$$

When internally generated, the programmed SPORT clock ($f_{SPTCLKPROG}$) frequency in MHz is set by the following equation where CLKDIV is a field in the SPORT_DIV register that can be set from 0 to 65,535:

$$f_{SPTCLKPROG} = \frac{f_{SCLK0}}{(CLKDIV + 1)}$$

$$t_{SPTCLKPROG} = \frac{1}{f_{SPTCLKPROG}}$$

Table 66. Serial Ports—External Clock¹

Parameter	Min	Max	Unit
<i>Timing Requirements</i>			
t _{SFSE} Frame Sync Setup Before SPTx_CLK (Externally Generated Frame Sync in either Transmit or Receive Mode) ²	2		ns
t _{HFSE} Frame Sync Hold After SPTx_CLK (Externally Generated Frame Sync in either Transmit or Receive Mode) ²	2.7		ns
t _{SDRE} Receive Data Setup Before Receive SPTx_CLK ²	2		ns
t _{HDRE} Receive Data Hold After SPTx_CLK ²	2.7		ns
t _{SPTCLKW} SPTx_CLK Width ³	$0.5 \times t_{SPTCLKEXT} - 1.5$		ns
t _{SPTCLK} SPTx_CLK Period ³	$t_{SPTCLKEXT} - 1.5$		ns
<i>Switching Characteristics</i>			
t _{DFSE} Frame Sync Delay After SPTx_CLK (Internally Generated Frame Sync in either Transmit or Receive Mode) ⁴		14.5	ns
t _{HOFSE} Frame Sync Hold After SPTx_CLK (Internally Generated Frame Sync in either Transmit or Receive Mode) ⁴	2		ns
t _{DDTE} Transmit Data Delay After Transmit SPTx_CLK ⁴		14	ns
t _{HDTE} Transmit Data Hold After Transmit SPTx_CLK ⁴	2		ns

¹Specifications apply to all eight SPORTs.

²Referenced to sample edge.

³This specification indicates the minimum instantaneous width or period that can be tolerated due to duty cycle variation or jitter on the external SPTx_CLK. For the external SPTx_CLK ideal maximum frequency see the $f_{SPTCLKEXT}$ specification in [Table 29](#).

⁴Referenced to drive edge.

ADSP-SC582/SC583/SC584/SC587/SC589/ADSP-21583/21584/21587

Table 67. Serial Ports—Internal Clock¹

Parameter		Min	Max	Unit
<i>Timing Requirements</i>				
t _{SFSI}	Frame Sync Setup Before SPTx_CLK (Externally Generated Frame Sync in either Transmit or Receive Mode) ²	12		ns
t _{HFSI}	Frame Sync Hold After SPTx_CLK (Externally Generated Frame Sync in either Transmit or Receive Mode) ²	-0.5		ns
t _{SDRI}	Receive Data Setup Before SPTx_CLK ²	3.4		ns
t _{HDRI}	Receive Data Hold After SPTx_CLK ²	1.5		ns
<i>Switching Characteristics</i>				
t _{DFSI}	Frame Sync Delay After SPTx_CLK (Internally Generated Frame Sync in Transmit or Receive Mode) ³		3.5	ns
t _{HOFSI}	Frame Sync Hold After SPTx_CLK (Internally Generated Frame Sync in Transmit or Receive Mode) ³	-2.5		ns
t _{DDTI}	Transmit Data Delay After SPTx_CLK ³		3.5	ns
t _{HDTI}	Transmit Data Hold After SPTx_CLK ³	-2.5		ns
t _{SCLKIW}	SPTx_CLK Width ⁴	0.5 × t _{SPTCLKPROG} - 1.5		ns
t _{SPTCLK}	SPTx_CLK Period ⁴	t _{SPTCLKPROG} - 1.5		ns

¹ Specifications apply to all eight SPORTs.

² Referenced to the sample edge.

³ Referenced to drive edge.

⁴ See Table 29 for details on the minimum period that can be programmed for t_{SPTCLKPROG}.

ADSP-SC582/SC583/SC584/SC587/SC589/ADSP-21583/21584/21587

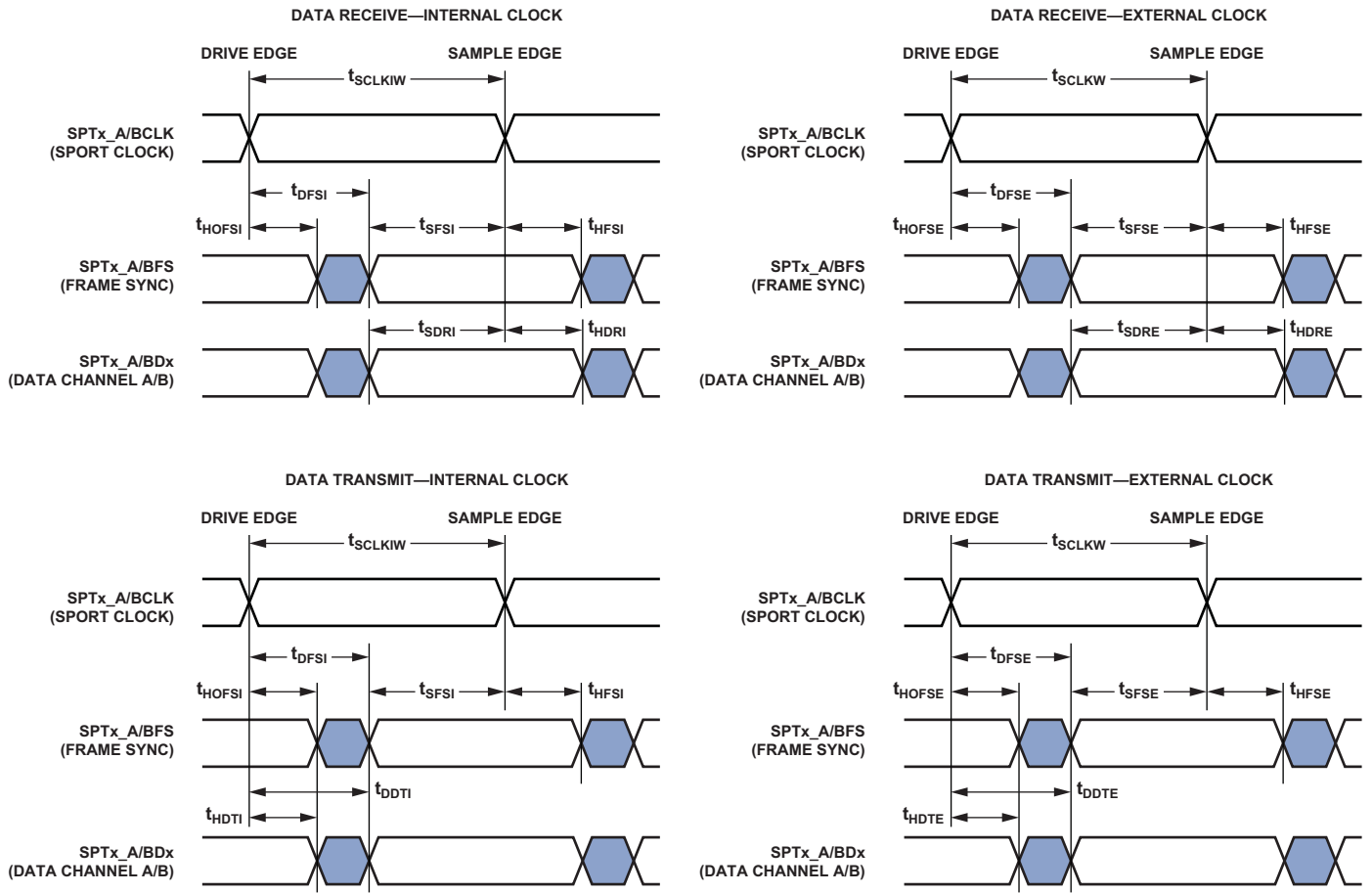

Figure 38. Serial Ports

ADSP-SC582/SC583/SC584/SC587/SC589/ADSP-21583/21584/21587

Table 68. Serial Ports—Enable and Three-State¹

Parameter		Min	Max	Unit
<i>Switching Characteristics</i>				
t _{DDTEN}	Data Enable from External Transmit SPTx_CLK ²	1		ns
t _{DDTTE}	Data Disable from External Transmit SPTx_CLK ²		14	ns
t _{DDTIN}	Data Enable from Internal Transmit SPTx_CLK ²	-2.5		ns
t _{DDTTI}	Data Disable from Internal Transmit SPTx_CLK ²		2.8	ns

¹Specifications apply to all eight SPORTs.

²Referenced to drive edge.

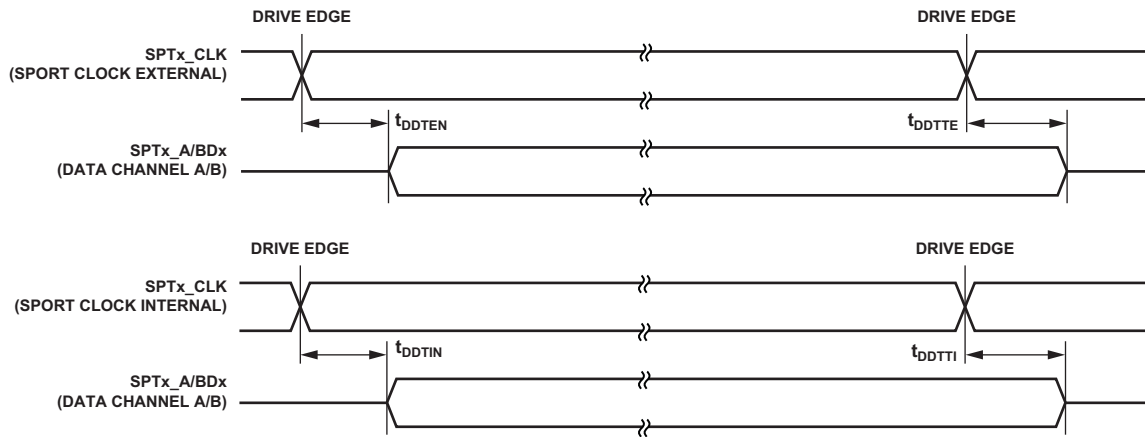

Figure 39. Serial Ports—Enable and Three-State

ADSP-SC582/SC583/SC584/SC587/SC589/ADSP-21583/21584/21587

The SPTx_TDV output signal becomes active in SPORT multichannel mode. During transmit slots (enabled with active channel selection registers) the SPTx_TDV is asserted for communication with external devices.

Table 69. Serial Ports—TDV (Transmit Data Valid)¹

Parameter	Min	Max	Unit
<i>Switching Characteristics</i>			
t_{DRDVEN} Data Valid Enable Delay from Drive Edge of External Clock ²	2		ns
t_{DFDVEN} Data Valid Disable Delay from Drive Edge of External Clock ²		14	ns
t_{DRDVIN} Data Valid Enable Delay from Drive Edge of Internal Clock ²	-2.5		ns
t_{DFDVIN} Data Valid Disable Delay from Drive Edge of Internal Clock ²		3.5	ns

¹ Specifications apply to all eight SPORTs.

² Referenced to drive edge.

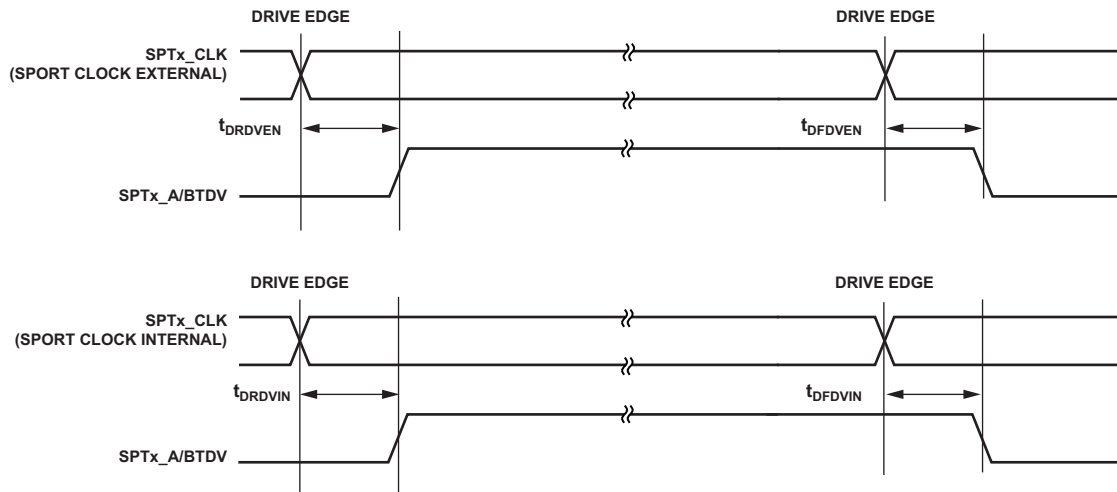

Figure 40. Serial Ports—Transmit Data Valid Internal and External Clock

ADSP-SC582/SC583/SC584/SC587/SC589/ADSP-21583/21584/21587

Table 70. Serial Ports—External Late Frame Sync¹

Parameter	Min	Max	Unit
<i>Switching Characteristics</i>			
t_{DDLSE} Data Delay from Late External Transmit Frame Sync or External Receive Frame Sync with MCE = 1, MFD = 0 ²		14	ns
$t_{DDTENFS}$ Data Enable for MCE = 1, MFD = 0 ²	0.5		ns

¹Specifications apply to all eight SPORTs.

²The t_{DDLSE} and $t_{DDTENFS}$ parameters apply to left justified as well as standard serial mode and MCE = 1, MFD = 0.

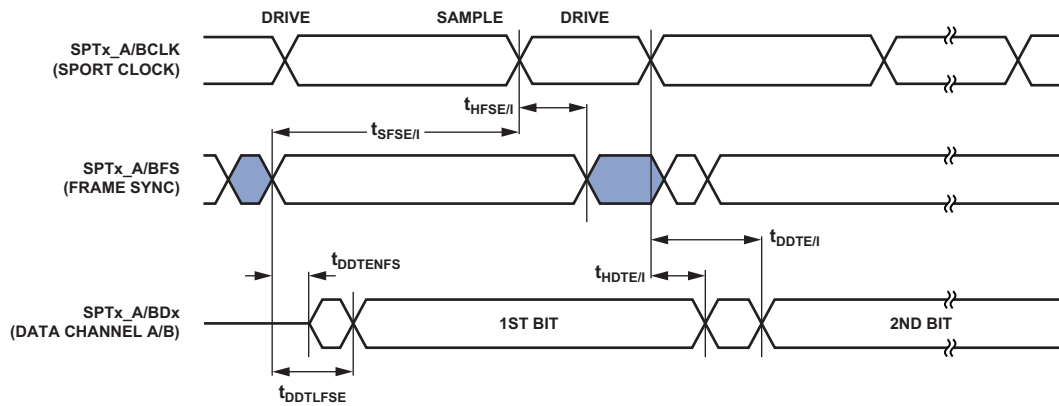

Figure 41. External Late Frame Sync

ADSP-SC582/SC583/SC584/SC587/SC589/ADSP-21583/21584/21587

Sample Rate Converter—Serial Input Port

The ASRC input signals are routed from the DAIx_PINx pins using the SRU. Therefore, the timing specifications provided in [Table 71](#) are valid at the DAIx_PINx pins.

Table 71. ASRC, Serial Input Port

Parameter	Min	Max	Unit
<i>Timing Requirements</i>			
t_{SRCSFS}^1 Frame Sync Setup Before Serial Clock Rising Edge	4		ns
t_{SRCHFS}^1 Frame Sync Hold After Serial Clock Rising Edge	5.5		ns
t_{SRCSD}^1 Data Setup Before Serial Clock Rising Edge	4		ns
t_{SRCHD}^1 Data Hold After Serial Clock Rising Edge	5.5		ns
t_{SRCLKW} Clock Width	$t_{\text{SCLK0}} - 1$		ns
t_{SRCLK} Clock Period	$2 \times t_{\text{SCLK0}}$		ns

¹ The serial clock, data, and frame sync signals can come from any of the DAI pins. The serial clock and frame sync signals can also come via PCG or SPORTs. The input of the PCG can be either CLKIN or any of the DAI pins.

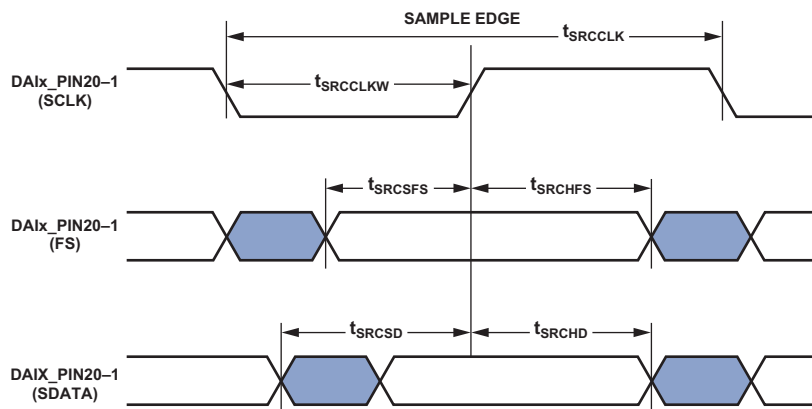

Figure 42. ASRC Serial Input Port Timing

ADSP-SC582/SC583/SC584/SC587/SC589/ADSP-21583/21584/21587

Sample Rate Converter—Serial Output Port

For the serial output port, the frame sync is an input and it must meet setup and hold times with regard to SCLK on the output port. The serial data output has a hold time and delay specification with regard to serial clock. The serial clock rising edge is the sampling edge, and the falling edge is the drive edge.

Table 72. ASRC, Serial Output Port

Parameter	Min	Max	Unit
<i>Timing Requirements</i>			
t_{SRCSFS}^1 Frame Sync Setup Before Serial Clock Rising Edge	4		ns
t_{SRCHFS}^1 Frame Sync Hold After Serial Clock Rising Edge	5.5		ns
t_{SRCLKW} Clock Width	$t_{SCLK0} - 1$		ns
t_{SRCLK} Clock Period	$2 \times t_{SCLK0}$		ns
<i>Switching Characteristics</i>			
t_{SRCTDD}^1 Transmit Data Delay After Serial Clock Falling Edge		13	ns
t_{SRCTDH}^1 Transmit Data Hold After Serial Clock Falling Edge	1		ns

¹The serial clock, data, and frame sync signals can come from any of the DAI pins. The serial clock and frame sync signals can also come via PCG or SPORTs. The input of the PCG can be either CLKIN, SCLK0, or any of the DAI pins.

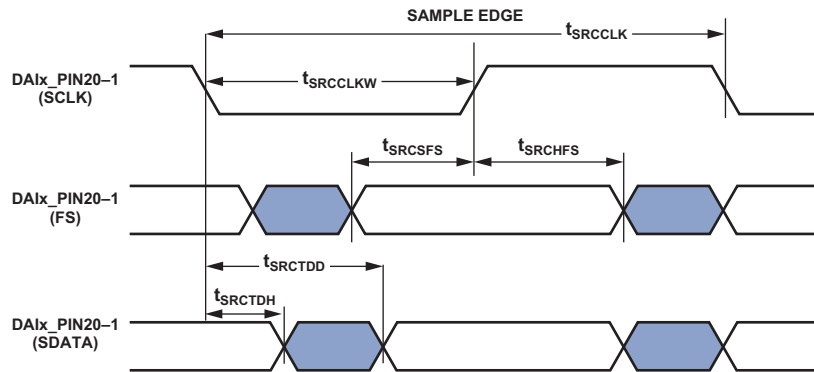

Figure 43. ASRC Serial Output Port Timing

ADSP-SC582/SC583/SC584/SC587/SC589/ADSP-21583/21584/21587

SPI Port—Master Timing

Table 73 and Figure 44 describe SPI port master operations.

When internally generated, the programmed SPI clock ($f_{SPICLKPROG}$) frequency in MHz is set by the following equation where BAUD is a field in the SPIx_CLK register that can be set from 0 to 65,535:

$$f_{SPICLKPROG} = \frac{f_{SCLK1}}{(BAUD + 1)}$$

$$t_{SPICLKPROG} = \frac{1}{f_{SPICLKPROG}}$$

Note that

- In dual-mode data transmit, the SPIx_MISO signal is an output.
- In quad-mode data transmit, the SPIx_MISO, SPIx_D2, and SPIx_D3 signals are outputs.
- In dual-mode data receive, the SPIx_MOSI signal is an input.
- In quad-mode data receive, the SPIx_MOSI, SPIx_D2, and SPIx_D3 signals are inputs.
- Quad-mode is supported by SPI2 only.
- CPHA is a configuration bit in the SPI_CTL register.

Table 73. SPI Port—Master Timing¹

Parameter	Min	Max	Unit
<i>Timing Requirements</i>			
t _{SSPIDM} Data Input Valid to SPIx_CLK Edge (Data Input Setup)	3.2		ns
t _{HSPIDM} SPIx_CLK Sampling Edge to Data Input Invalid	1.2		ns
<i>Switching Characteristics</i>			
t _{SDSCIM} $\overline{SPIx_SEL}$ Low to First SPI_CLK Edge for CPHA = 1	$t_{SCLK1} - 2$		ns
$\overline{SPIx_SEL}$ Low to First SPI_CLK Edge for CPHA = 0	$1.5 \times t_{SCLK1} - 2$		ns
t _{SPICHM} SPIx_CLK High Period ²	$0.5 \times t_{SPICLKPROG} - 1$		ns
t _{SPICLM} SPIx_CLK Low Period ²	$0.5 \times t_{SPICLKPROG} - 1$		ns
t _{SPICLK} SPIx_CLK Period ²	$t_{SPICLKPROG} - 1$		ns
t _{HDSM} Last SPIx_CLK Edge to $\overline{SPIx_SEL}$ High for CPHA = 1	$1.5 \times t_{SCLK1} - 2$		ns
Last SPIx_CLK Edge to $\overline{SPIx_SEL}$ High for CPHA = 0	$t_{SCLK1} - 2$		ns
t _{SPITDM} Sequential Transfer Delay ³	$t_{SCLK1} - 1$		ns
t _{DDSPIDM} SPIx_CLK Edge to Data Out Valid (Data Out Delay)		2.6	ns
t _{HDSPIDM} SPIx_CLK Edge to Data Out Invalid (Data Out Hold)	-1.5		ns

¹ All specifications apply to all three SPIs.

² See Table 29 for details on the minimum period that can be programmed for $t_{SPICLKPROG}$.

³ Applies to sequential mode with STOP ≥ 1.

ADSP-SC582/SC583/SC584/SC587/SC589/ADSP-21583/21584/21587

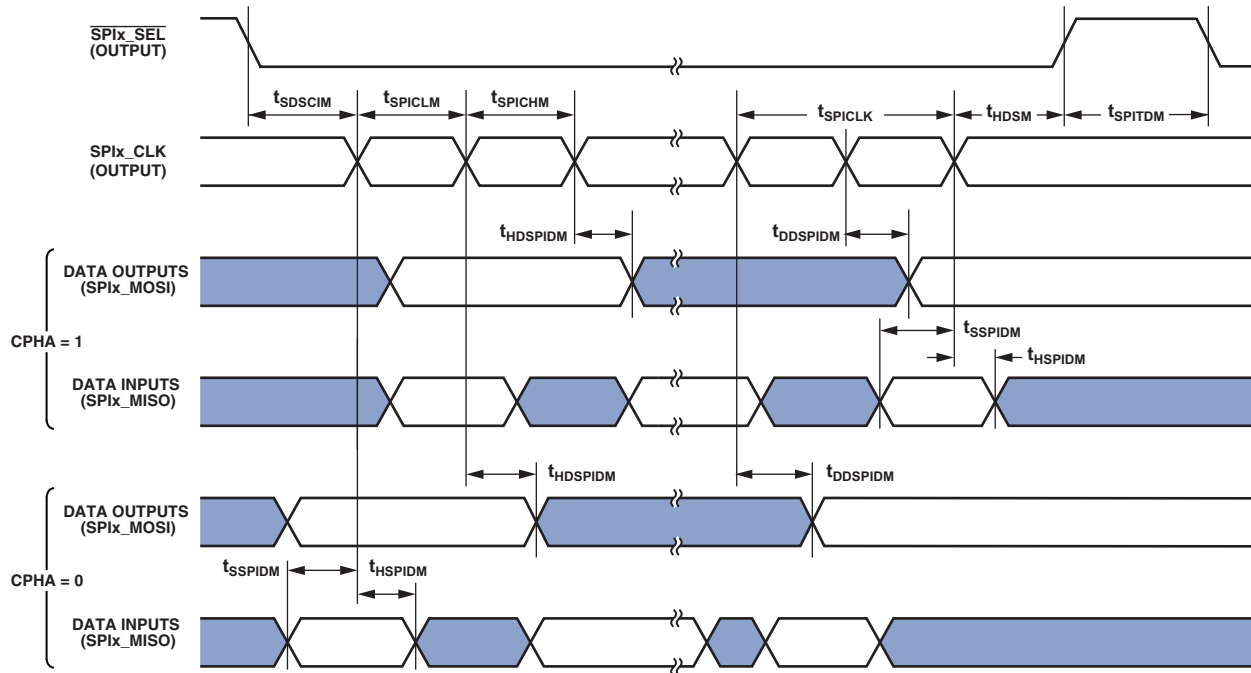

Figure 44. SPI Port—Master Timing

ADSP-SC582/SC583/SC584/SC587/SC589/ADSP-21583/21584/21587

SPI Port—Slave Timing

Table 74 and Figure 45 describe SPI port slave operations. Note that

- In dual-mode data transmit, the SPIx_MOSI signal is an output.
- In quad-mode data transmit, the SPIx_MOSI, SPIx_D2, and SPIx_D3 signals are outputs.
- In dual-mode data receive, the SPIx_MISO signal is an input.
- In quad-mode data receive, the SPIx_MISO, SPIx_D2, and SPIx_D3 signals are inputs.
- In SPI slave mode, the SPI clock is supplied externally and is called $f_{SPICLKEXT}$, as follows:

$$t_{SPICLKEXT} = \frac{1}{f_{SPICLKEXT}}$$

- Quad mode is supported by SPI2 only.
- CPHA is a configuration bit in the SPI_CTL register.

Table 74. SPI Port—Slave Timing¹

Parameter	Min	Max	Unit	
<i>Timing Requirements</i>				
tSPICH _S	SPIx_CLK High Period ²	0.5 × tSPICLKEXT – 1	ns	
tSPICL _S	SPIx_CLK Low Period ²	0.5 × tSPICLKEXT – 1	ns	
tSPICL _K	SPIx_CLK Period ²	tSPICLKEXT – 1	ns	
tHDS	Last SPIx_CLK Edge to $\overline{\text{SPIx_SS}}$ Not Asserted	5	ns	
tSPITDS	Sequential Transfer Delay	tSPICLK – 1	ns	
tSDSCI	$\overline{\text{SPIx_SS}}$ Assertion to First SPIx_CLK Edge	10.5	ns	
tSSPID	Data Input Valid to SPIx_CLK Edge (Data Input Setup)	2	ns	
tHSPID	SPIx_CLK Sampling Edge to Data Input Invalid	1.6	ns	
<i>Switching Characteristics</i>				
tDSOE	$\overline{\text{SPIx_SS}}$ Assertion to Data Out Active	0	14	ns
tDSDHI	$\overline{\text{SPIx_SS}}$ Deassertion to Data High Impedance	0	12.5	ns
tDDSPID	SPIx_CLK Edge to Data Out Valid (Data Out Delay)		14	ns
tHDSPID	SPIx_CLK Edge to Data Out Invalid (Data Out Hold)	0		ns

¹ All specifications apply to all three SPIs.

² This specification indicates the minimum instantaneous width or period that can be tolerated due to duty cycle variation or jitter on the external SPIx_CLK. For the external SPIx_CLK ideal maximum frequency, see the $f_{SPICLKTEXT}$ specification in Table 29.

ADSP-SC582/SC583/SC584/SC587/SC589/ADSP-21583/21584/21587

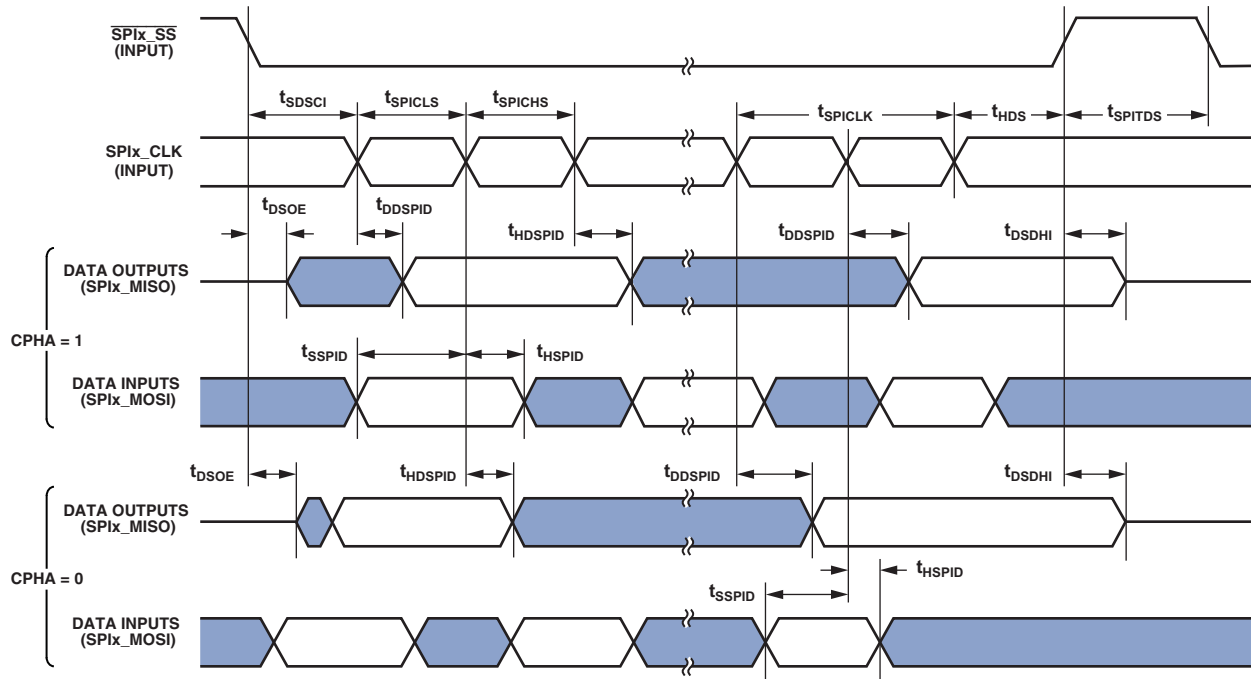

Figure 45. SPI Port—Slave Timing

ADSP-SC582/SC583/SC584/SC587/SC589/ADSP-21583/21584/21587

SPI Port—SPI Ready (SPIx_RDY) Slave Timing

SPIx_RDY is used to provide flow control. CPOL, CPHA, and FCCH are configuration bits in the SPIx_CTL register.

Table 75. SPI Port—SPIx_RDY Slave Timing¹

Parameter	Conditions	Min	Max	Unit
<i>Switching Characteristic</i>				
t _{DSPISCKRDYS} SPIx_RDY Deassertion from Last Valid Input SPIx_CLK Edge	FCCH = 0	3 × t _{SCLK1}	4 × t _{SCLK1} + 10	ns
	FCCH = 1	4 × t _{SCLK1}	5 × t _{SCLK1} + 10	ns

¹All specifications apply to all three SPIs.

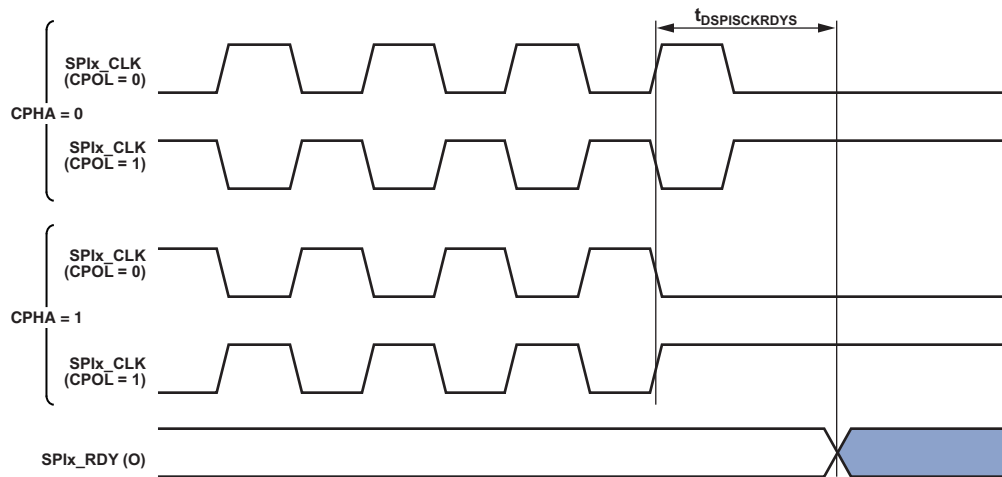

Figure 46. SPIx_RDY Deassertion from Valid Input SPIx_CLK Edge in Slave Mode

ADSP-SC582/SC583/SC584/SC587/SC589/ADSP-21583/21584/21587

SPI Port—Open Drain Mode (ODM) Timing

In Figure 47 and Figure 48 and Table 77 and Table 78, the outputs can be SPIx_MOSI, SPIx_MISO, SPIx_D2, and/or SPIx_D3, depending on the mode of operation. CPOL and CPHA are configuration bits in the SPI_CTL register.

Table 76. SPI Port—ODM Master Mode¹

Parameter	Min	Max	Unit
<i>Switching Characteristics</i>			
t_{HDSPIDMM} SPIx_CLK Edge to High Impedance from Data Out Valid	-1		ns
t_{DDSPIDMM} SPIx_CLK Edge to Data Out Valid from High Impedance	-1	+6	ns

¹All specifications apply to all three SPIs.

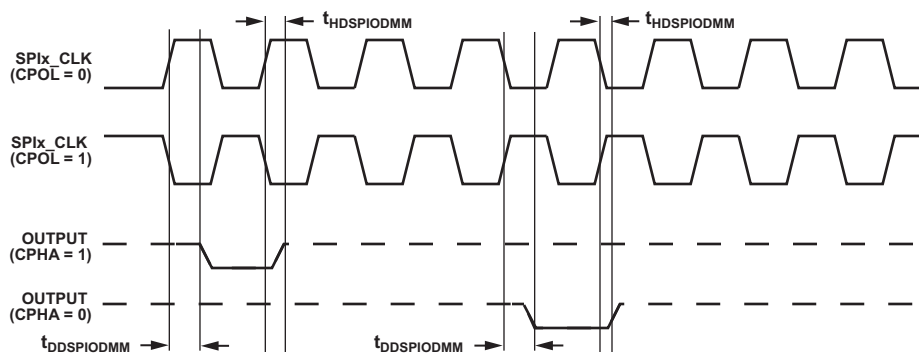

Figure 47. ODM Master Mode

Table 77. SPI Port—ODM Slave Mode¹

Parameter	Min	Max	Unit
<i>Timing Requirements</i>			
t_{HDSPIDMS} SPIx_CLK Edge to High Impedance from Data Out Valid	0		ns
t_{DDSPIDMS} SPIx_CLK Edge to Data Out Valid from High Impedance		11	ns

¹All specifications apply to all three SPIs.

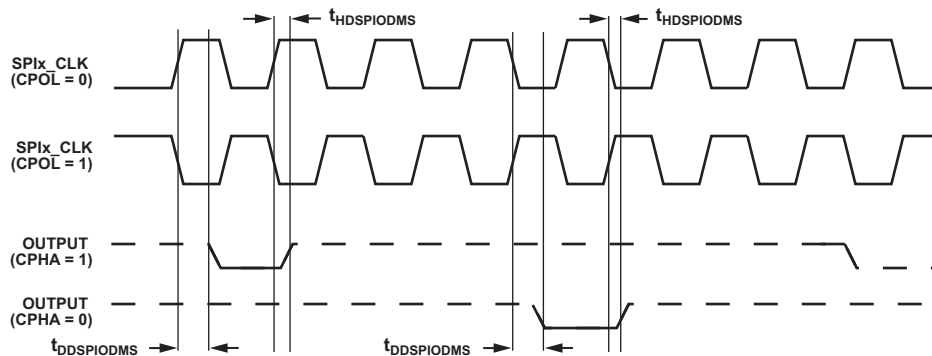

Figure 48. ODM Slave Mode

ADSP-SC582/SC583/SC584/SC587/SC589/ADSP-21583/21584/21587

SPI Port—SPI_x_RDY Master Timing

SPI_x_RDY provides flow control. CPOL and CPHA are configuration bits in the SPI_x_CTL register, whereas LEADX, LAGX, and STOP are configuration bits in the SPI_x_DLY register.

Table 78. SPI Port—SPI_x_RDY Master Timing¹

Parameter	Conditions	Min	Max	Unit
<i>Timing Requirement</i>				
t _{SRDYSCKM} Setup Time for SPI _x _RDY Deassertion Before Last Valid Data SPI _x _CLK Edge		$(2 + 2 \times \text{BAUD}^2) \times t_{\text{SCLK1}} + 10$		ns
<i>Switching Characteristic</i>				
t _{DRDYSCKM} ³ Assertion of SPI _x _RDY to First SPI _x _CLK Edge of Next Transfer	Baud = 0, CPHA = 0	$4.5 \times t_{\text{SCLK1}}$	$5.5 \times t_{\text{SCLK1}} + 10$	ns
	Baud = 0, CPHA = 1	$4 \times t_{\text{SCLK1}}$	$5 \times t_{\text{SCLK1}} + 10$	ns
	Baud > 0, CPHA = 0	$(1 + 1.5 \times \text{BAUD}^2) \times t_{\text{SCLK1}}$	$(2 + 2.5 \times \text{BAUD}^2) \times t_{\text{SCLK1}} + 10$	ns
	Baud > 0, CPHA = 1	$(1 + 1 \times \text{BAUD}^2) \times t_{\text{SCLK1}}$	$(2 + 2 \times \text{BAUD}^2) \times t_{\text{SCLK1}} + 10$	ns

¹ All specifications apply to all three SPIs.

² BAUD value is set using the SPI_x_CLK.BAUD bits. BAUD value = SPI_x_CLK.BAUD bits + 1.

³ Specification assumes the LEADX, LAGX, and STOP bits in the SPI_x_DLY register are zero.

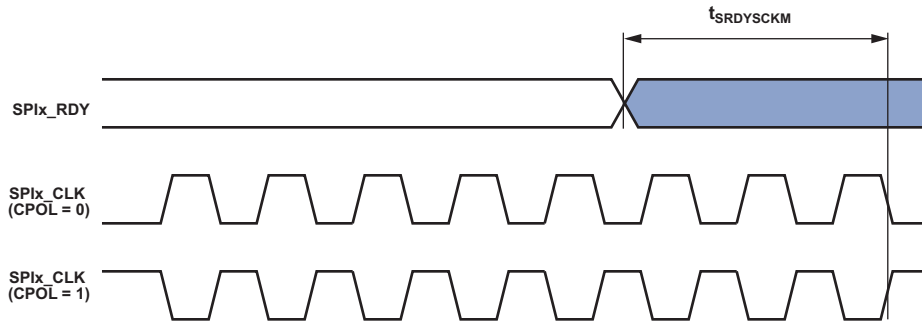

Figure 49. SPI_x_RDY Setup Before SPI_x_CLK

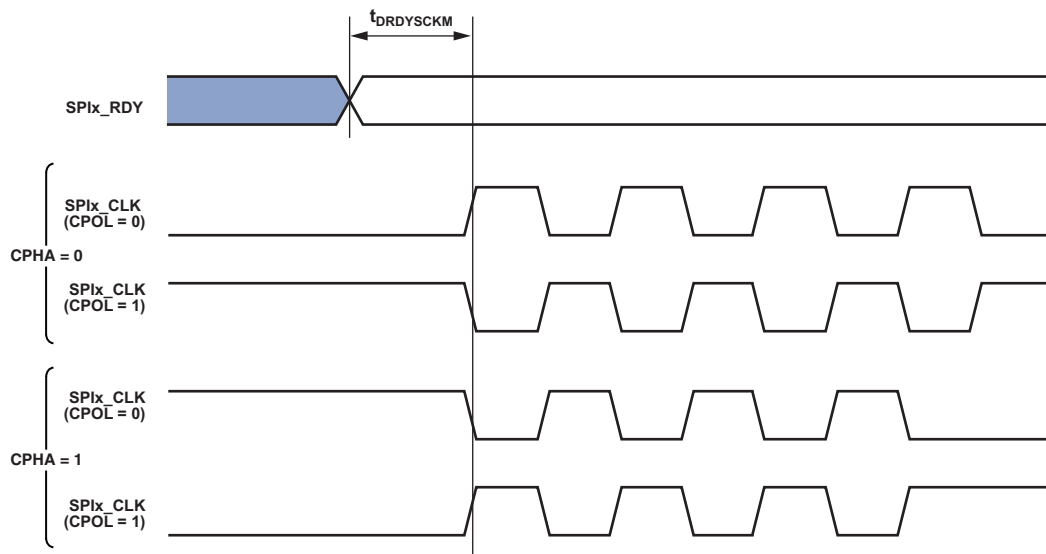

Figure 50. SPIx_CLK Switching Diagram After SPIx_RDY Assertion

ADSP-SC582/SC583/SC584/SC587/SC589/ADSP-21583/21584/21587

Precision Clock Generator (PCG) (Direct Pin Routing)

This timing is only valid when the SRU is configured such that the precision clock generator (PCG) takes inputs directly from the DAI pins (via pin buffers) and sends outputs directly to the DAI pins. For the other cases, where the PCG inputs and outputs are not directly routed to/from DAI pins (via pin buffers), there is no timing data available. All timing parameters and switching characteristics apply to external DAI pins (DAIx_PINx).

Table 79. Precision Clock Generator (Direct Pin Routing)

Parameter	Min	Max	Unit
<i>Timing Requirements</i>			
t_{PCGIP} Input Clock Period	$t_{SCLK} \times 2$		ns
t_{STRIG} PCG Trigger Setup Before Falling Edge of PCG Input Clock	4.5		ns
t_{HTRIG} PCG Trigger Hold After Falling Edge of PCG Input Clock	3		ns
<i>Switching Characteristics</i>			
t_{DPCGIO} PCG Output Clock and Frame Sync Active Edge Delay After PCG Input Clock	2.5	13.5	ns
$t_{DTRIGCLK}$ PCG Output Clock Delay After PCG Trigger	$2.5 + (2.5 \times t_{PCGIP})$	$13.5 + (2.5 \times t_{PCGIP})$	ns
$t_{DTRIGFS}^1$ PCG Frame Sync Delay After PCG Trigger	$2.5 + ((2.5 + D - PH) \times t_{PCGIP})$	$13.5 + ((2.5 + D - PH) \times t_{PCGIP})$	ns
t_{PCGOW}^2 Output Clock Period	$2 \times t_{PCGIP} - 1$		ns

¹D = FSxDIV, PH = FSxPHASE. For more information, see the [ADSP-SC58x/ADSP-2158x SHARC+ Processor Hardware Reference](#).

²Normal mode of operation.

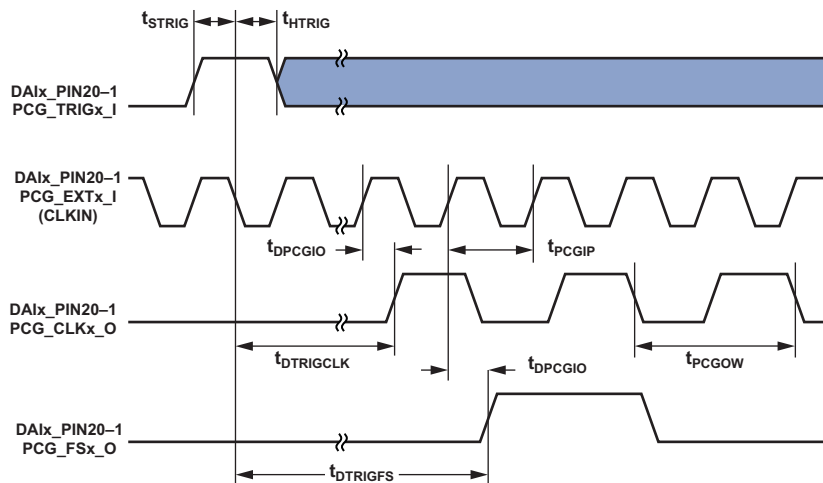

Figure 51. PCG (Direct Pin Routing)

ADSP-SC582/SC583/SC584/SC587/SC589/ADSP-21583/21584/21587

General-Purpose I/O Port Timing

Table 80 and Figure 52 describe I/O timing, related to the general-purpose I/O port.

Table 80. General-Purpose Port Timing

Parameter	Min	Max	Unit
<i>Timing Requirement</i>			
t_{WFI} General-Purpose Port Pin Input Pulse Width	$2 \times t_{SCLK0} - 1.5$		ns

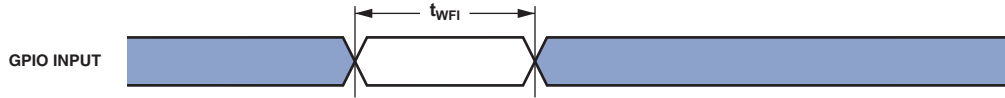

Figure 52. General-Purpose Port Pin Timing

General-Purpose I/O Timer Cycle Timing

Table 81, Table 82, and Figure 53 describe timer expired operations related to the general-purpose timer. The input signal is asynchronous in Width Capture Mode and External Clock Mode and has an absolute maximum input frequency of $f_{SCLK}/4$ MHz. The Width Value value is the timer period assigned in the TMx_TMRn_WIDTH register and can range from 1 to $2^{32} - 1$. When externally generated, the TMx_CLK clock is called $f_{TMRCLKEXT}$, as follows:

$$t_{TMRCLKEXT} = \frac{1}{f_{TMRCLKEXT}}$$

Table 81. Timer Cycle Timing (Internal Mode)

Parameter	Min	Max	Unit
<i>Timing Requirements</i>			
t_{WL} Timer Pulse Width Input Low (Measured In SCLK Cycles) ¹	$2 \times t_{SCLK}$		ns
t_{WH} Timer Pulse Width Input High (Measured In SCLK Cycles) ¹	$2 \times t_{SCLK}$		ns
<i>Switching Characteristic</i>			
t_{HTO} Timer Pulse Width Output (Measured In SCLK Cycles) ²	$t_{SCLK} \times WIDTH - 1.5$	$t_{SCLK} \times WIDTH + 1.5$	ns

¹The minimum pulse width applies for TMRx signals in width capture and external clock modes.

²WIDTH refers to the value in the TMx_WIDTH register (it can vary from 1 to $2^{32} - 1$).

Table 82. Timer Cycle Timing (External Mode)

Parameter	Min	Max	Unit
<i>Timing Requirements</i>			
t_{WL} Timer Pulse Width Input Low (Measured In EXT_CLK Cycles) ¹	$2 \times t_{EXT_CLK}$		ns
t_{WH} Timer Pulse Width Input High (Measured In EXT_CLK Cycles) ¹	$2 \times t_{EXT_CLK}$		ns
t_{EXT_CLK} Timer External Clock Period ²	$t_{TMRCLKEXT}$		ns
<i>Switching Characteristic</i>			
t_{HTO} Timer Pulse Width Output (Measured In EXT_CLK Cycles) ³	$t_{EXT_CLK} \times WIDTH - 1.5$	$t_{EXT_CLK} \times WIDTH + 1.5$	ns

¹The minimum pulse width applies for TMRx signals in width capture and external clock modes.

²This specification indicates the minimum instantaneous width or period that can be tolerated due to duty cycle variation or jitter on the external TMx_CLK . For the external TMx_CLK maximum frequency see the $f_{TMRCLKEXT}$ specification in Table 29.

³WIDTH refers to the value in the TMx_WIDTH register (it can vary from 1 to $2^{32} - 1$).

ADSP-SC582/SC583/SC584/SC587/SC589/ADSP-21583/21584/21587



Figure 53. Timer Cycle Timing

DAIx Pin to DAIx Pin Direct Routing (DAI0 Block and DAI1 Block)

Table 83 and Figure 54 describe I/O timing related to the digital audio interface (DAI) for direct pin connections only (for example, DAIx_PB01_I to DAIx_PB02_O).

Table 83. DAI Pin to DAI Pin Routing

Parameter	Min	Max	Unit
<i>Switching Characteristic</i>			
t_{DPIO} Delay DAI Pin Input Valid to DAI Output Valid	1.5	12	ns

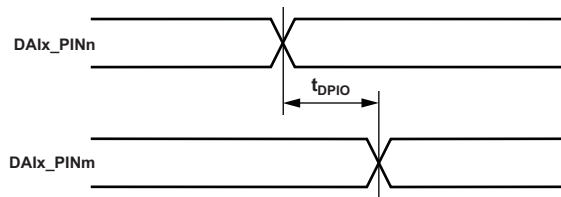

Figure 54. DAI Pin to DAI Pin Direct Routing

Up/Down Counter/Rotary Encoder Timing

Table 84 and Figure 55 describe timing related to the general-purpose counter (CNT).

Table 84. Up/Down Counter/Rotary Encoder Timing

Parameter	Min	Max	Unit
<i>Timing Requirement</i>			
t_{WCOUNT} Up/Down Counter/Rotary Encoder Input Pulse Width	$2 \times t_{SCLK0}$		ns



Figure 55. Up/Down Counter/Rotary Encoder Timing

ADSP-SC582/SC583/SC584/SC587/SC589/ADSP-21583/21584/21587

Pulse Width Modulator (PWM) Timing

Table 85 and Figure 56 describe timing, related to the PWM.

Table 85. PWM Timing¹

Parameter	Min	Max	Unit
<i>Timing Requirement</i>			
t_{ES} External Sync Pulse Width	$2 \times t_{SCLK0}$		ns
<i>Switching Characteristics</i>			
t_{DODIS} Output Inactive (off) After Trip Input ²		15	ns
t_{DOE} Output Delay After External Sync ^{2, 3}	$2 \times t_{SCLK0} + 5.5$	$5 \times t_{SCLK0} + 14$	ns

¹ All specifications apply to all three PWMs.

² PWM outputs are PWMx_AH, PWMx_AL, PWMx_BH, PWMx_BL, PWMx_CH, and PWMx_CL.

³ When the external sync signal is synchronous to the peripheral clock, it takes fewer clock cycles for the output to appear compared to when the external sync signal is asynchronous to the peripheral clock.

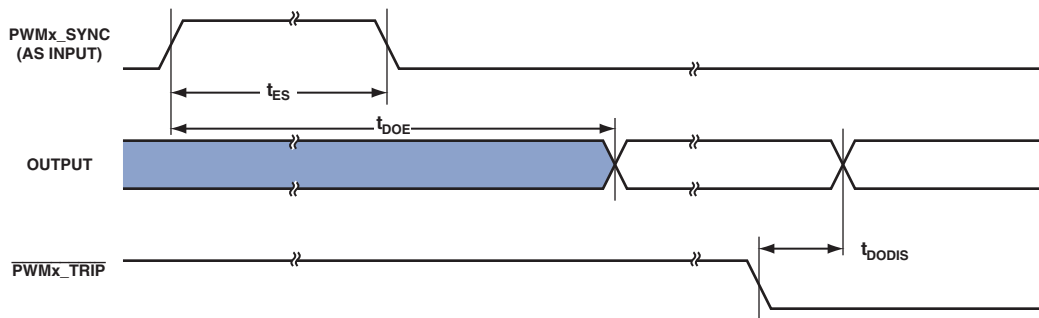

Figure 56. PWM Timing

ADSP-SC582/SC583/SC584/SC587/SC589/ADSP-21583/21584/21587

PWM — Medium Precision (MP) Mode Timing

Table 86 and Figure 57 describe medium precision (MP) PWM operations.

Table 86. PWM—MP Mode, Output Pulse

Parameter	Min	Max	Unit
<i>Switching Characteristic</i>			
t_{MPWMW} MP PWM Output Pulse Width ^{1, 2}	$(N + m \times 0.25) \times t_{SCLK} - 1.0$	$(N + m \times 0.25) \times t_{SCLK} + 1.0$	ns

¹N is the DUTY bit field (coarse duty) from the duty register. m is the ENHDIV (Enhanced Precision Divider bits) value from the HP duty register.

²Applies to individual PWM channel with 50% duty cycle. Other PWM channels within the same unit are toggling at the same time. No other GPIO pins toggle.

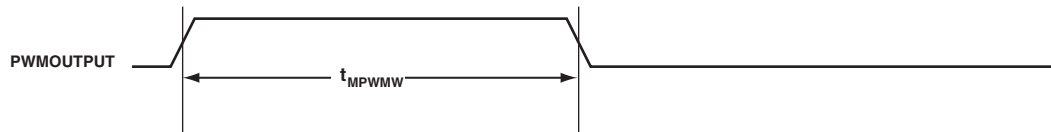

Figure 57. PWM MP Mode Timing, Output Pulse

PWM — Heightened Precision (HP) Mode Timing

Table 87, Table 88, and Figure 58 through Figure 61 describe heightened precision (HP) PWM operations.

Table 87. PWM—HP Mode (HPPWM), Output Pulse Width Accuracy

Parameter	Conditions	Min	Typ	Max	Unit
HPPWM Pulse Width Accuracy Resolution ^{1, 2}	Maximum allowed heightened precision divider bits for fractional duty cycles within system clock period			4	Bits
Differential Nonlinearity (DNL) ^{1, 3}	Guaranteed monotonic	-0.99		+1.0	LSB
Integral Nonlinearity (INL) ^{1, 4}		-1.0		+1.0	LSB
RMS Jitter ¹	RMS jitter of any given pulse width code step		200		ps

¹This specification applies when the system clock SCLK0 is running at 112.5 and 125 MHz.

²See Figure 58 for an example of 4-bit resolution of fractional duty cycle edge placement.

³DNL definition. See Figure 59 for an example of DNL calculation. For each heightened precision duty register value (n) is as follows:

$$DNL(n) = \frac{PW(n) - PW(n-1)}{IdealLSBStepWidth} - 1$$

⁴INL definition. See Figure 60 for an example of INL calculation. For each heightened precision duty register value (n) is as follows:

$$INL(n) = \left| \frac{PW(n) - PW(0)}{IdealLSBPulseWidth} - n \right|$$

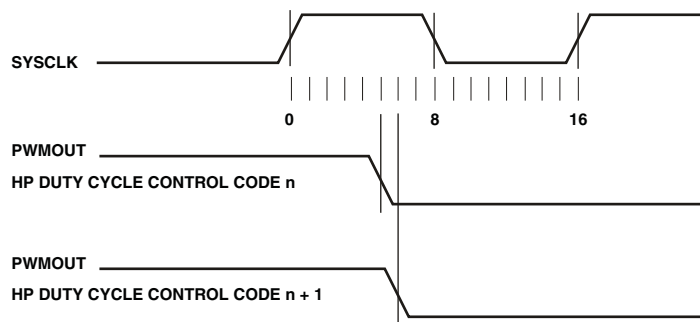

Figure 58. Fractional Duty Cycle Edge Placement (4-Bit Resolution)

ADSP-SC582/SC583/SC584/SC587/SC589/ADSP-21583/21584/21587

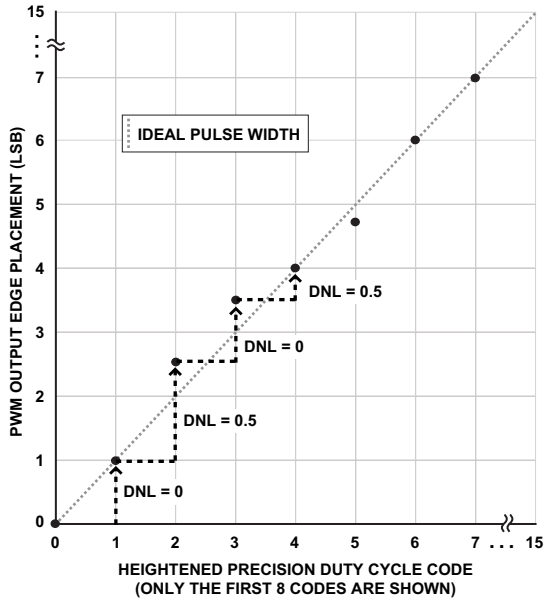

Figure 59. HPPWM Pulse Width Accuracy: DNL Calculation

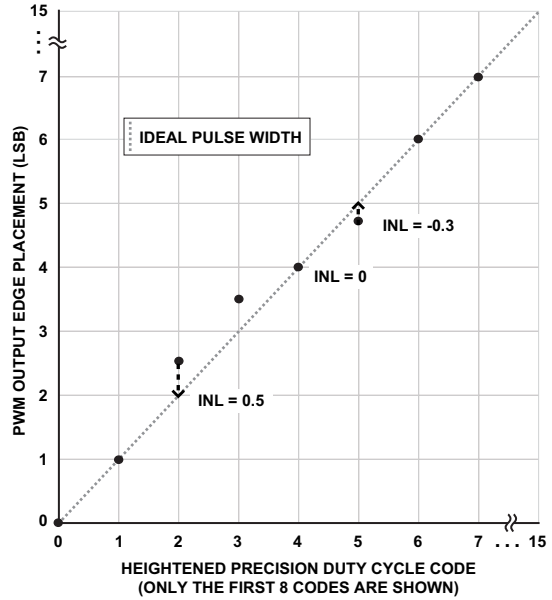

Figure 60. HPPWM Pulse Width Accuracy: INL Calculation

Note that Figure 59 and Figure 60 show sample data for calculating DNL and INL, respectively. They do not reflect actual measured performance.

Table 88. PWM—HP and MP Modes, Output Skew

Parameter	Min	Max	Unit
<i>Switching Characteristic</i>			
t_{PWMS} HP and MP PWM Output Skew ¹		1.0	ns

¹ Output edge difference between any two PWM channels (AH, AL, BH, BL, CH, CL, DH and DL) in the same PWM unit (a unit is PWMx where x = 0, 1, 2), with the same HP/MP edge placement.

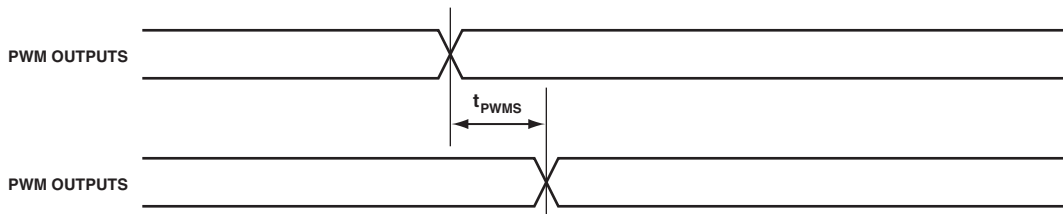

Figure 61. PWM HP and MP Modes Timing, Output Skew

ADSP-SC582/SC583/SC584/SC587/SC589/ADSP-21583/21584/21587

ADC Controller Module (ACM) Timing

Table 89 and Figure 62 describe ACM operations.

When internally generated, the programmed ACM clock ($f_{ACLKPROG}$) frequency in MHz is set by the following equation where CKDIV is a field in the ACM_TC0 register and ranges from 1 to 255:

$$f_{ACLKPROG} = \frac{f_{SCLK1}}{CKDIV + 1}$$

$$t_{ACLKPROG} = \frac{1}{f_{ACLKPROG}}$$

Setup cycles (SC) in Table 89 is also a field in the ACM0_TC0 register and ranges from 0 to 4095. Hold cycles (HC) is a field in the ACM0_TC1 register that ranges from 0 to 15.

Table 89. ACM Timing

Parameter		Min	Max	Unit
<i>Timing Requirements</i>				
t_{SDR}	SPORT DRxPRI/DRxSEC Setup Before ACMx_CLK	3.5		ns
t_{HDR}	SPORT DRxPRI/DRxSEC Hold After ACMx_CLK	1.5		ns
<i>Switching Characteristics</i>				
t_{SCTLCS}	ACM Controls (ACMx_A[4:0]) Setup Before Assertion of \overline{CS}	$(SC + 1) \times t_{SCLK1} - 3$		ns
t_{HCTLCS}	ACM Control (ACMx_A[4:0]) Hold After Deassertion of \overline{CS}	$HC \times t_{ACLKPROG} - 1$		ns
t_{ACLKW}	ACM Clock Pulse Width ¹	$(0.5 \times t_{ACLKPROG}) - 1.5$		ns
t_{ACLK}	ACM Clock Period ¹	$t_{ACLKPROG} - 1.5$		ns
$t_{HCSACLK}$	\overline{CS} Hold to ACMx_CLK Edge	-2.5		ns
$t_{SCSACLK}$	\overline{CS} Setup to ACMx_CLK Edge	$t_{ACLKPROG} - 3.5$		ns

¹ See Table 29 for details on the minimum period that can be programmed for $t_{ACLKPROG}$.

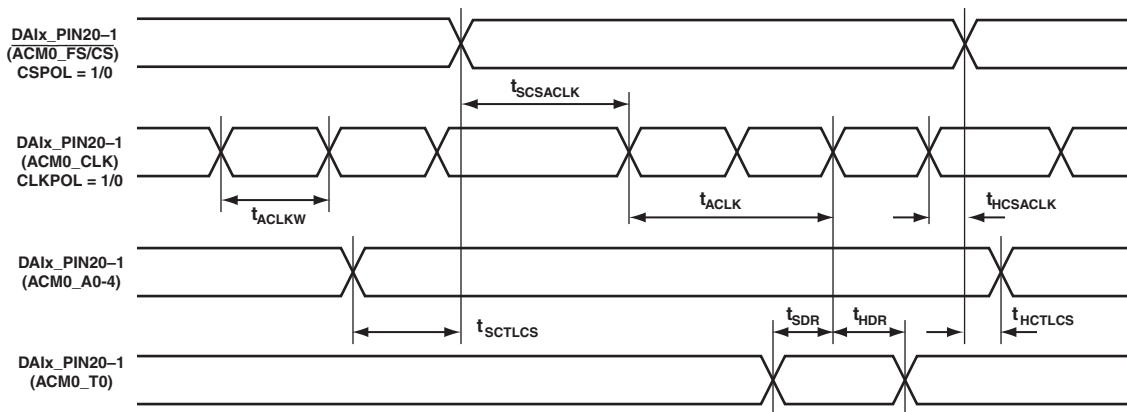

Figure 62. ACM Timing

ADSP-SC582/SC583/SC584/SC587/SC589/ADSP-21583/21584/21587

Universal Asynchronous Receiver-Transmitter (UART) Ports—Receive and Transmit Timing

The UART ports receive and transmit operations are described in the [ADSP-SC58x/ADSP-2158x SHARC+ Processor Hardware Reference](#).

Controller Area Network (CAN) Interface

The CAN interface timing is described in the [ADSP-SC58x/ADSP-2158x SHARC+ Processor Hardware Reference](#).

Universal Serial Bus (USB)

[Table 90](#) describes the universal serial bus (USB) clock timing. Refer to the *USB 2.0 Specification* for timing and dc specifications for USB pins (including output characteristics for driver types E, F, and G listed in the [ADSP-SC58x/ADSP-2158x Designer Quick Reference](#)).

Table 90. USB Clock Timing¹

Parameter		Min	Max	Unit
<i>Timing Requirements</i>				
f _{USBS}	USB_CLKIN Frequency	24	24	MHz
f _{USB}	USB_CLKIN Clock Frequency Stability	-50	+50	ppm

¹This specification is supported by USB0.

PCI Express (PCIe)

The PCIe interface complies with the Gen1 and Gen2 x1 lane data rate specification and supports up to 3.0 PCIe base functionality.

For more information about PCIe, see the following standards:

- *PCI Express Base 3.0 Specification*, Revision 1.0, PCI-SIG
- *PCI Express 2.0 Card Electromechanical Specification*, Revision 2.0, PCI-SIG
- *PHY Interface for the PCI Express Architecture*, Revision 2.0, Intel Corporation
- *PCI-SIG Engineering Change Request: L1 Substates*, February 1, 2012, PCI-SIG
- *IEEE Standard 1149.1-2001*, IEEE
- *IEEE Standard 1149.6-2003*, IEEE

ADSP-SC582/SC583/SC584/SC587/SC589/ADSP-21583/21584/21587

10/100 EMAC Timing (ETH0 and ETH1)

Table 91 through Table 93 and Figure 63 through Figure 65 describe the RMII EMAC operations.

Table 91. 10/100 EMAC Timing—RMII Receive Signal¹

Parameter ²	Min	Max	Unit
<i>Timing Requirements</i>			
$t_{REFCLKF}$ ETHx_REFCLK Frequency ($f_{SCLK0} = SCLK0$ Frequency)		50 + 1%	MHz
$t_{REFCLKW}$ ETHx_REFCLK Width ($t_{REFCLKF} = ETHx_REFCLK$ Period)	$t_{REFCLKF} \times 35\%$	$t_{REFCLKF} \times 65\%$	ns
$t_{REFCLKIS}$ Rx Input Valid to RMII ETHx_REFCLK Rising Edge (Data Input Setup)	1.75		ns
$t_{REFCLKIH}$ RMII ETHx_REFCLK Rising Edge to Rx Input Invalid (Data Input Hold)	1.6		ns

¹These specifications apply to ETH0 and ETH1.

²RMII inputs synchronous to RMII ETHx_REFCLK are ETHx_RXD1-0, RMII ETHx_CRS, and ERxER.

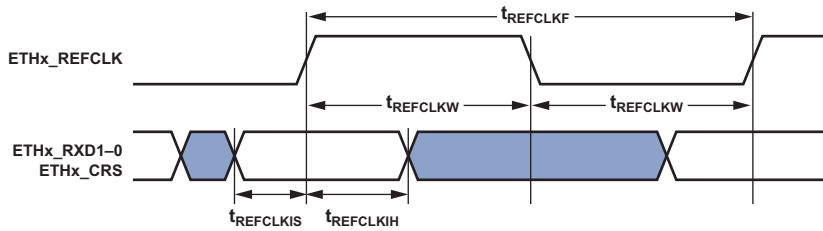

Figure 63. 10/100 EMAC Controller Timing—RMII Receive Signal

Table 92. 10/100 EMAC Timing—RMII Transmit Signal¹

Parameter ²	Min	Max	Unit
<i>Switching Characteristics</i>			
$t_{REFCLKOV}$ RMII ETHx_REFCLK Rising Edge to Transmit Output Valid (Data Out Valid)		11.9	ns
$t_{REFCLKOH}$ RMII ETHx_REFCLK Rising Edge to Transmit Output Invalid (Data Out Hold)	2		ns

¹These specifications apply to ETH0 and ETH1.

²RMII outputs synchronous to RMII ETHx_REFCLK are ETHx_TXD1 and TXD0.

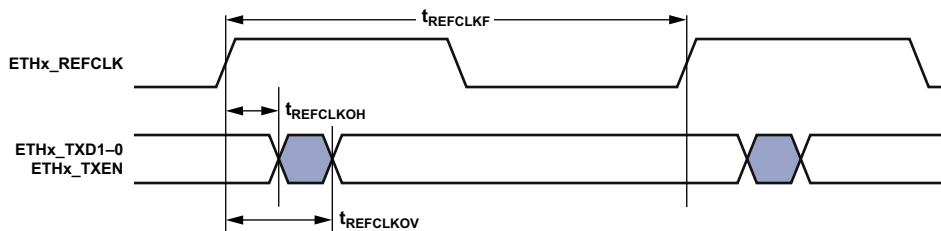

Figure 64. 10/100 EMAC Controller Timing—RMII Transmit Signal

ADSP-SC582/SC583/SC584/SC587/SC589/ADSP-21583/21584/21587

Table 93. EMAC Timing— Station Management¹

Parameter ²	Min	Max	Unit
<i>Timing Requirements</i>			
t_{MDIOS} ETHx_MDIO Input Valid to ETHx_MDC Rising Edge (Setup)	10.8		ns
t_{MDCIH} ETHx_MDC Rising Edge to ETHx_MDIO Input Invalid (Hold)	0		ns
<i>Switching Characteristics</i>			
t_{MDCOV} ETHx_MDC Falling Edge to ETHx_MDIO Output Valid		$t_{SCLK0} + 2$	ns
t_{MDCOH} ETHx_MDC Falling Edge to ETHx_MDIO Output Invalid (Hold)	$t_{SCLK0} - 2.9$		ns

¹These specifications apply to ETH0 and ETH1.

²ETHx_MDC/ETHx_MDIO is a 2-wire serial bidirectional port for controlling one or more external PHYs. ETHx_MDC is an output clock with a minimum period that is programmable as a multiple of the system clock SCLK0. ETHx_MDIO is a bidirectional data line.

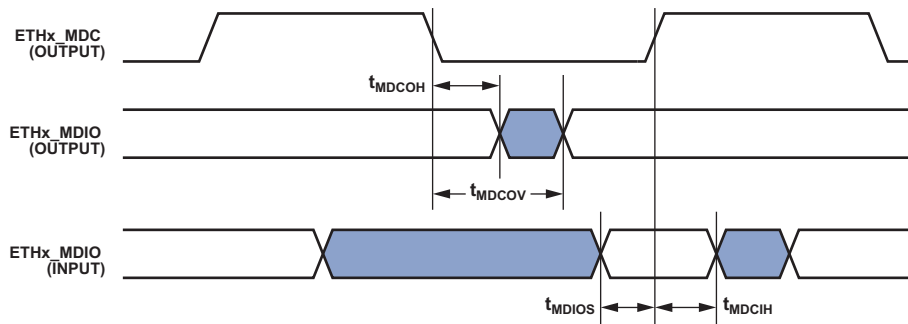

Figure 65. Ethernet MAC Controller Timing— Station Management

ADSP-SC582/SC583/SC584/SC587/SC589/ADSP-21583/21584/21587

10/100/1000 EMAC Timing (ETH0 Only)

Table 94 and Figure 66 describe the RGMII EMAC timing.

Table 94. 10/100/1000 EMAC Timing—RGMII Receive and Transmit Signals¹

Parameter		Min	Max	Unit
<i>Timing Requirements</i>				
t _{SETUPR}	Data to Clock Input Setup at Receiver	1		ns
t _{HOLDR}	Data to Clock Input Hold at Receiver	1		ns
t _{GREFCLKF}	RGMII Receive Clock Period	8		ns
t _{GREFCLKW}	RGMII Receive Clock Pulse Width	4		ns
<i>Switching Characteristics</i>				
t _{SKEWT}	Data to Clock Output Skew at Transmitter	-0.5	0.5	ns
t _{CYC}	Clock Cycle Duration	7.2	8.8	ns
t _{DUTY_G}	Duty Cycle for RGMII Minimum	t _{GREFCLKF} × 45%	t _{GREFCLKF} × 55%	ns

¹This specification is supported by ETH0 only (10/100/1000 EMAC controller).

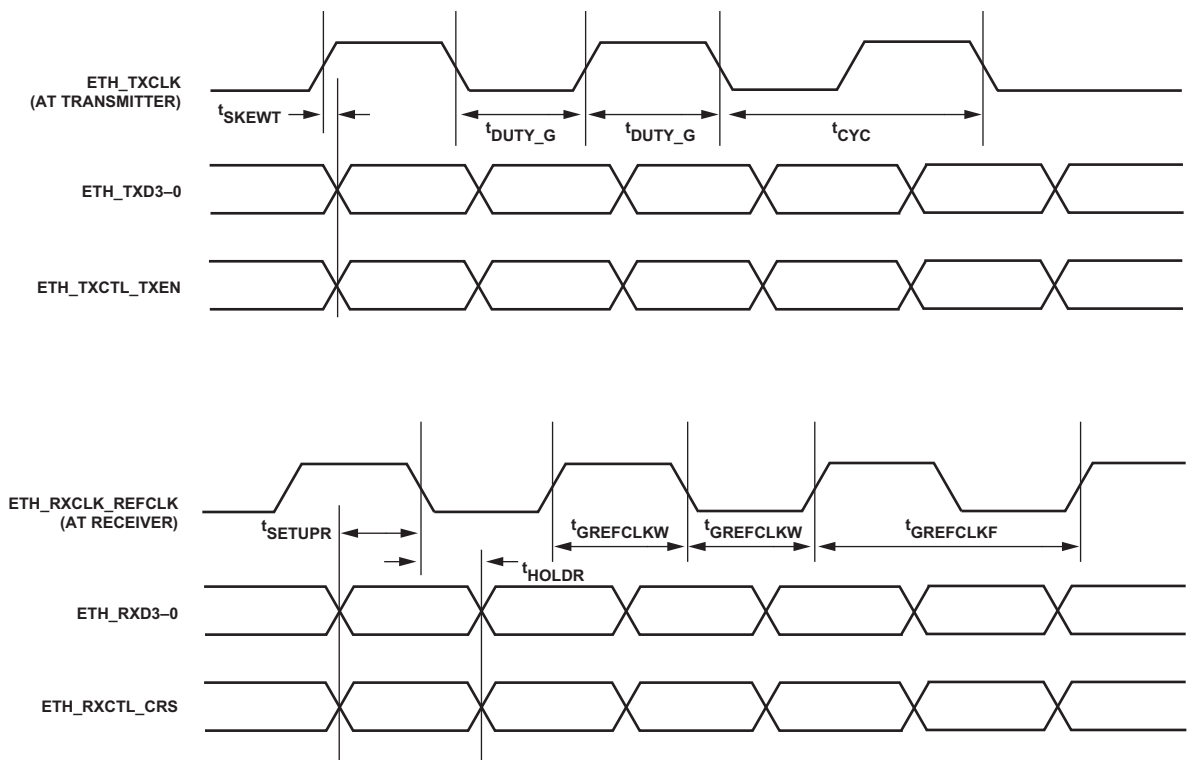

Figure 66. Gigabit EMAC Controller Timing—RGMII

ADSP-SC582/SC583/SC584/SC587/SC589/ADSP-21583/21584/21587

Sinus Cardinalis (SINC) Filter Timing

The programmed SINC filter clock ($f_{\text{SINCLKPROG}}$) frequency in MHz is set by the following equation where MDIV is a field in the CLK control register that can be set from 4 to 63:

$$f_{\text{SINCLKPROG}} = \frac{f_{\text{SCLK}}}{\text{MDIV}}$$

$$t_{\text{SINCLKPROG}} = \frac{1}{f_{\text{SINCLKPROG}}}$$

Table 95. SINC Timing

Parameter	Min	Max	Unit
<i>Timing Requirements</i>			
t_{SSINC} SINC0_Dx Setup Before SINC0_CLKx Rise	13.5		ns
t_{HSINC} SINC0_Dx Hold After SINC0_CLKx Rise	0		ns
<i>Switching Characteristics</i>			
t_{SINCLK} SINC0_CLKx Period ¹	$t_{\text{SINCLKPROG}} - 2.5$		ns
t_{SINCLKW} SINC0_CLKx Width ¹	$0.5 \times t_{\text{SINCLKPROG}} - 2.5$		ns

¹ See Table 29 for details on the minimum period that may be programmed for $t_{\text{SINCLKPROG}}$.

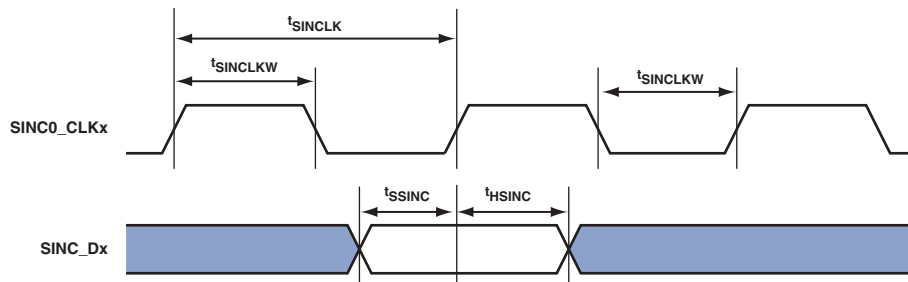

Figure 67. SINC Timing

ADSP-SC582/SC583/SC584/SC587/SC589/ADSP-21583/21584/21587

Sony/Philips Digital Interface (S/PDIF) Transmitter

Serial data input to the S/PDIF transmitter can be formatted as left justified, I²S, or right justified with word widths of 16, 18, 20, or 24 bits. The following sections provide timing for the transmitter.

S/PDIF Transmitter Serial Input Waveforms

Figure 68 and Table 96 show the right justified mode. Frame sync is high for the left channel and low for the right channel. Data is valid on the rising edge of serial clock. The MSB is delayed the minimum in 24-bit output mode or the maximum in 16-bit output mode from a frame sync transition, so that when there are 64 serial clock periods per frame sync period, the LSB of the data is right justified to the next frame sync transition.

Table 96. S/PDIF Transmitter Right Justified Mode

Parameter	Conditions	Nominal	Unit
<i>Timing Requirement</i>			
t_{RJD}	Frame Sync to MSB Delay in Right Justified Mode	16 14 12 8	SCLK SCLK SCLK SCLK

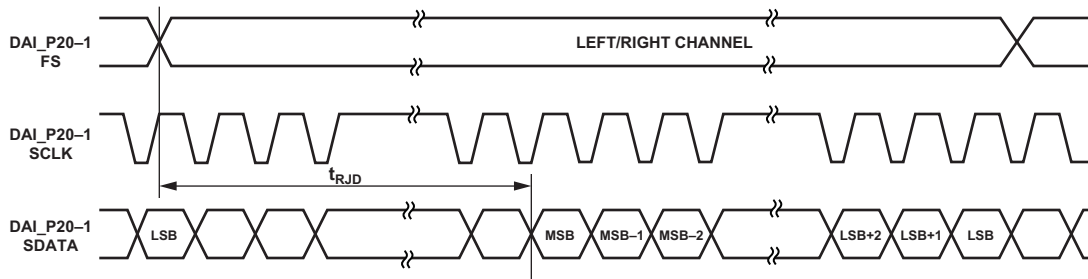

Figure 68. Right Justified Mode

ADSP-SC582/SC583/SC584/SC587/SC589/ADSP-21583/21584/21587

Figure 69 and Table 97 show the default I²S justified mode. The frame sync is low for the left channel and high for the right channel. Data is valid on the rising edge of serial clock. The MSB is left justified to the frame sync transition but with a delay.

Table 97. S/PDIF Transmitter I²S Mode

Parameter	Nominal	Unit
<i>Timing Requirement</i>		
t_{I2SD} Frame Sync to MSB Delay in I ² S Mode	1	SCLK

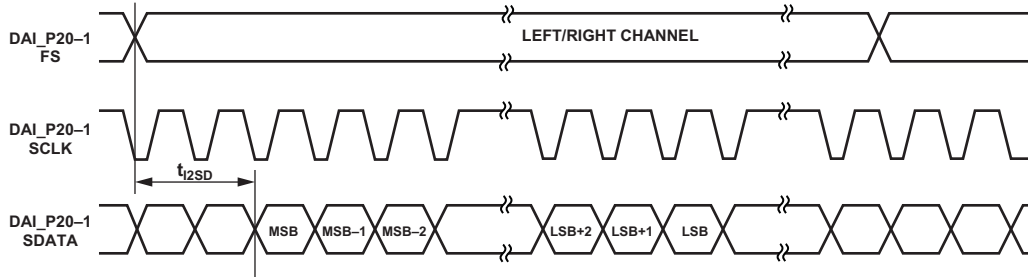

Figure 69. I²S Justified Mode

Figure 70 and Table 98 show the left justified mode. The frame sync is high for the left channel and low for the right channel. Data is valid on the rising edge of serial clock. The MSB is left justified to the frame sync transition with no delay.

Table 98. S/PDIF Transmitter Left Justified Mode

Parameter	Nominal	Unit
<i>Timing Requirement</i>		
t_{LJD} Frame Sync to MSB Delay in Left Justified Mode	0	SCLK

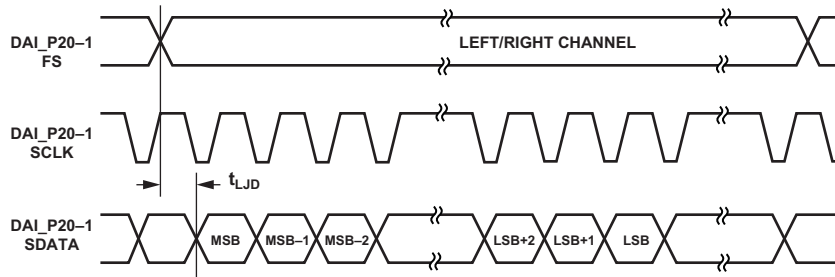

Figure 70. Left Justified Mode

ADSP-SC582/SC583/SC584/SC587/SC589/ADSP-21583/21584/21587

S/PDIF Transmitter Input Data Timing

The timing requirements for the S/PDIF transmitter are given in Table 99. Input signals are routed to the DAIx_PINx pins using the SRU. Therefore, the timing specifications provided below are valid at the DAIx_PINx pins.

Table 99. S/PDIF Transmitter Input Data Timing

Parameter	Min	Max	Unit
<i>Timing Requirements</i>			
t_{SISFS}^1 Frame Sync Setup Before Serial Clock Rising Edge	3		ns
t_{SIHFS}^1 Frame Sync Hold After Serial Clock Rising Edge	3		ns
t_{SISD}^1 Data Setup Before Serial Clock Rising Edge	3		ns
t_{SIHD}^1 Data Hold After Serial Clock Rising Edge	3		ns
$t_{SITXCLKW}$ Transmit Clock Width	9		ns
$t_{SITXCLK}$ Transmit Clock Period	20		ns
$t_{SISCLKW}$ Clock Width	36		ns
t_{SISCLK} Clock Period	80		ns

¹The serial clock, data, and frame sync signals can come from any of the DAI pins. The serial clock and frame sync signals can also come via PCG or SPORTs. The input of the PCG can be either CLKIN or any of the DAI pins.

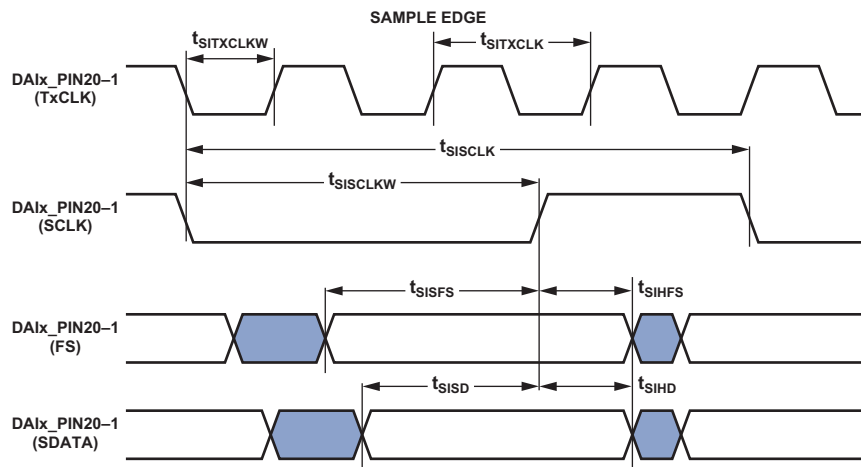

Figure 71. S/PDIF Transmitter Input Timing

Oversampling Clock (TxCLK) Switching Characteristics

The S/PDIF transmitter requires an oversampling clock input. This high frequency clock (TxCLK) input is divided down to generate the internal biphase clock.

Table 100. Oversampling Clock (TxCLK) Switching Characteristics

Parameter	Max	Unit
<i>Switching Characteristics</i>		
f_{TXCLK_384} Frequency for TxCLK = 384 × Frame Sync	Oversampling ratio × frame sync ≤ 1/ $t_{SITXCLK}$	MHz
f_{TXCLK_256} Frequency for TxCLK = 256 × Frame Sync	49.2	MHz
f_{FS} Frame Rate (FS)	192.0	kHz

ADSP-SC582/SC583/SC584/SC587/SC589/ADSP-21583/21584/21587

S/PDIF Receiver

The following section describes timing as it relates to the S/PDIF receiver.

Internal Digital PLL Mode

In the internal digital PLL mode, the internal digital PLL generates the $512 \times FS$ clock.

Table 101. S/PDIF Receiver Internal Digital PLL Mode Timing

Parameter	Min	Max	Unit
<i>Switching Characteristics</i>			
t_{DFSI} Frame Sync Delay After Serial Clock		5	ns
t_{HOFSI} Frame Sync Hold After Serial Clock	-2		ns
t_{DDTI} Transmit Data Delay After Serial Clock		5	ns
t_{HDTI} Transmit Data Hold After Serial Clock	-2		ns

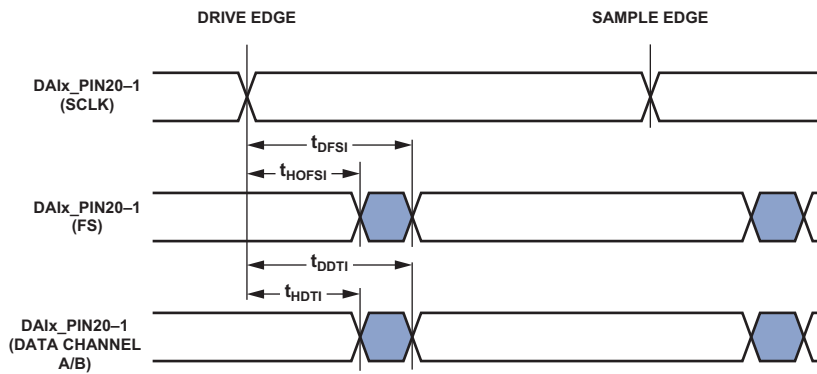

Figure 72. S/PDIF Receiver Internal Digital PLL Mode Timing

ADSP-SC582/SC583/SC584/SC587/SC589/ADSP-21583/21584/21587

Media LB (MLB)

All the numbers shown in [Table 102](#) are applicable for all MLB speed modes (1024 FS, 512 FS, and 256 FS) for the 3-pin protocol, unless otherwise specified. Refer to the *Media Local Bus Specification version 4.2* for more details.

Table 102. 3-Pin MLB Interface Specifications

Parameter	Min	Typ	Max	Unit
t _{MLBCLK}	MLB Clock Period			
		20.3		ns
		40		ns
t _{MCKL}	MLBCLK Low Time			
	6.1			ns
	14			ns
t _{MCKH}	MLBCLK High Time			
	9.3			ns
	14			ns
t _{MCKR}	MLBCLK Rise Time (V _{IL} to V _{IH})			
			1	ns
			3	ns
t _{MCKF}	MLBCLK Fall Time (V _{IH} to V _{IL})			
			1	ns
			3	ns
t _{MPWV} ¹	MLBCLK Pulse Width Variation			
			0.7	nspp
			2.0	nspp
t _{DSMCF}	DAT/SIG Input Setup Time			ns
t _{DHMcF}	DAT/SIG Input Hold Time			ns
t _{MCFDZ}	DAT/SIG Output Time to Three-State		15	ns
t _{MCDRV}	DAT/SIG Output Data Delay From MLBCLK Rising Edge		8	ns
t _{MDZH} ²	Bus Hold Time			
	2			ns
	4			ns
C _{MLB}	DAT/SIG Pin Load			
			40	pf
			60	pf

¹ Pulse width variation is measured at 1.25 V by triggering on one edge of MLBCLK and measuring the spread on the other edge, measured in ns peak-to-peak.

² Board designs must ensure the high impedance bus does not leave the logic state of the final driven bit for this time period. Therefore, coupling must be minimized while meeting the maximum capacitive load listed.

ADSP-SC582/SC583/SC584/SC587/SC589/ADSP-21583/21584/21587

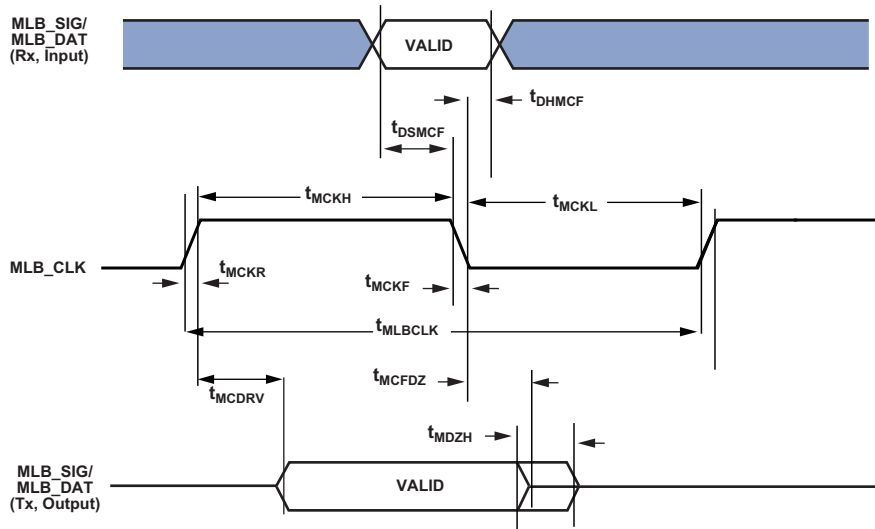

Figure 73. MLB Timing (3-Pin Interface)

The ac timing specifications of the 6-pin MLB interface is detailed in [Table 103](#). Refer to the *Media Local Bus Specification version 4.2* for more details.

Table 103. 6-Pin MLB Interface Specifications

Parameter	Conditions	Min	Typ	Max	Unit
t_{MT}	Differential Transition Time at the Input Pin (See Figure 74)			1	ns
f_{MCKE}	MLBCP/N External Clock Operating Frequency (See Figure 75) ¹	20% to 80% V_{IN+}/V_{IN-} 80% to 20% V_{IN+}/V_{IN-}			
		2048 × FS at 44.0 kHz	90.112		MHz
		2048 × FS at 50.0 kHz		102.4	MHz
f_{MCKR}	Recovered Clock Operating Frequency (Internal, not Observable at Pins, Only for Timing References) (See Figure 75)	2048 × FS at 44.0 kHz	90.112		MHz
		2048 × FS at 50.0 kHz		102.4	MHz
t_{DELAY}	Transmitter MLBSP/N (MLBDP/N) Output Valid From Transition of MLBCP/N (Low to High) (See Figure 76)	$f_{MCKR} = 2048 \times FS$	0.6	5	ns
t_{PHZ}	Disable Turnaround Time From Transition of MLBCP/N (Low to High) (See Figure 77)	$f_{MCKR} = 2048 \times FS$	0.6	7	ns
t_{PLZ}	Enable Turnaround Time From Transition of MLBCP/N (Low to High) (See Figure 77)	$f_{MCKR} = 2048 \times FS$	0.6	11.2	ns
t_{SU}	MLBSP/N (MLBDP/N) Valid to Transition of MLBCP/N (Low to High) (See Figure 76)	$f_{MCKR} = 2048 \times FS$	1		ns
t_{HD}	MLBSP/N (MLBDP/N) Hold From Transition of MLBCP/N (Low to High) (See Figure 76) ²		0.6		ns

¹ f_{MCKE} (maximum) and f_{MCKR} (maximum) include maximum cycle to cycle system jitter (t_{JITTER}) of 600 ps for a bit error rate of 10E-9.

² Receivers must latch MLBSP/N (MLBDP/N) data within t_{HD} (min) of the rising edge of MLBCP/N.

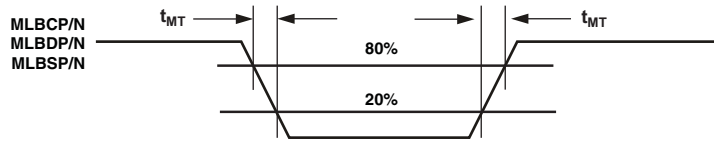
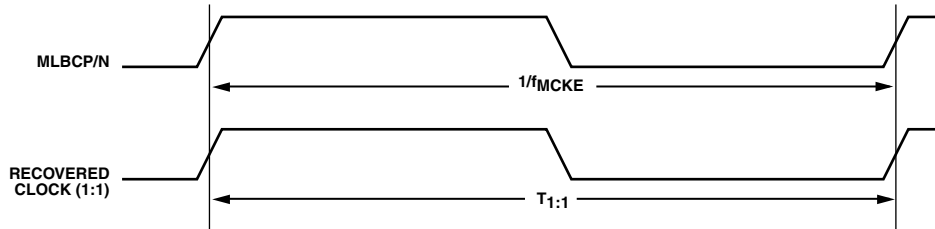

Figure 74. MLB 6-Pin Transition Time



NOTE: $T_{1:1} = 1/f_{MCKE}$

Figure 75. MLB 6-Pin Clock Definitions

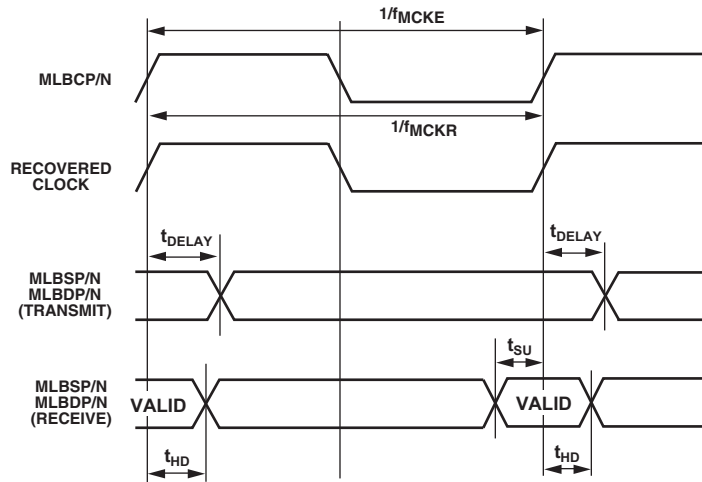

Figure 76. MLB 6-Pin Delay, Setup, and Hold Times

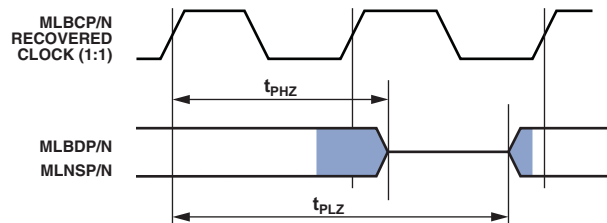

Figure 77. MLB 6-Pin Disable and Enable Turnaround Times

ADSP-SC582/SC583/SC584/SC587/SC589/ADSP-21583/21584/21587

Mobile Storage Interface (MSI) Controller Timing

Table 104 and Figure 78 show I/O timing related to the MSI.

Table 104. MSI Controller Timing

Parameter	Min	Max	Unit
<i>Timing Requirements</i>			
t_{SU} Input Setup Time	4.8		ns
t_{IH} Input Hold Time	-0.5		ns
<i>Switching Characteristics</i>			
f_{PP} Clock Frequency Data Transfer Mode ¹		50	MHz
t_{WL} Clock Low Time	8		ns
t_{WH} Clock High Time	8		ns
t_{TLH} Clock Rise Time		3	ns
t_{THL} Clock Fall Time		3	ns
t_{ODLY} Output Delay Time During Data Transfer Mode		2	ns
t_{OH} Output Hold Time	-1.8		ns

¹ $t_{pp} = 1/f_{pp}$.

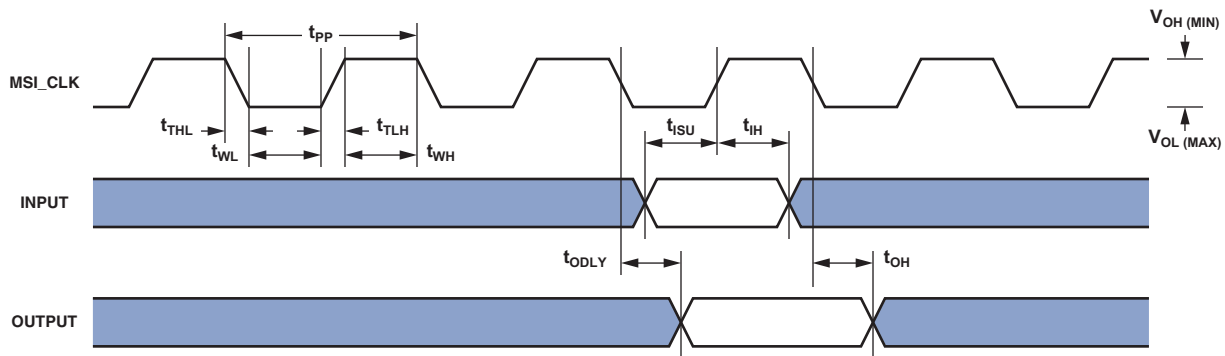

NOTES:
 1 INPUT INCLUDES MSI_Dx AND MSI_CMD SIGNALS.
 2 OUTPUT INCLUDES MSI_Dx AND MSI_CMD SIGNALS.

Figure 78. MSI Controller Timing

ADSP-SC582/SC583/SC584/SC587/SC589/ADSP-21583/21584/21587

Program Trace Macrocell (PTM) Timing

Table 105 and Figure 79 provide I/O timing related to the PTM.

Table 105. Trace Timing

Parameter		Min	Max	Unit
<i>Switching Characteristics</i>				
t_{DTRD}	Trace Data Delay From Trace Clock Maximum		$0.5 \times t_{SCLK0} + 2$	ns
t_{HTRD}	Trace Data Hold From Trace Clock Minimum	$0.5 \times t_{SCLK0} - 1.2$		ns
t_{PTRCK}	Trace Clock Period Minimum	$2 \times t_{SCLK0} - 1$		ns

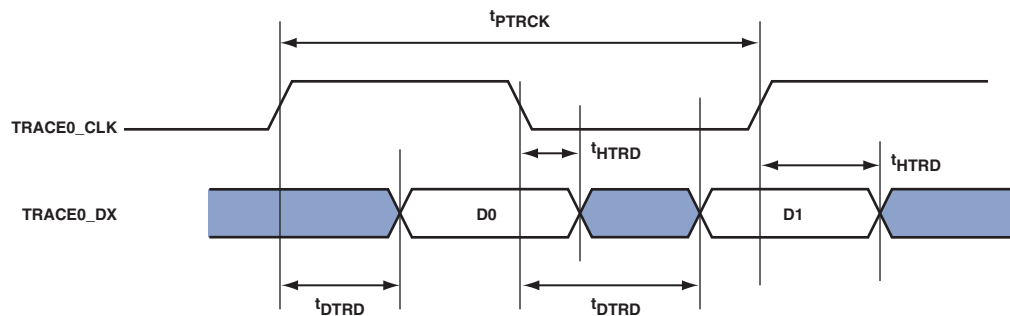

Figure 79. Trace Timing

ADSP-SC582/SC583/SC584/SC587/SC589/ADSP-21583/21584/21587

Debug Interface (JTAG Emulation Port) Timing

Table 106 and Figure 80 provide I/O timing related to the debug interface (JTAG Emulator Port).

Table 106. JTAG Emulation Port Timing

Parameter		Min	Max	Unit
<i>Timing Requirements</i>				
t_{TCK}	JTG_TCK Period	20		ns
t_{STAP}	JTG_TDI, JTG_TMS Setup Before JTG_TCK High	4		ns
t_{HTAP}	JTG_TDI, JTG_TMS Hold After JTG_TCK High	4		ns
t_{SSYS}	System Inputs Setup Before JTG_TCK High ¹	12		ns
t_{HSYS}	System Inputs Hold After JTG_TCK High ¹	5		ns
t_{TRSTW}	JTG_TRST Pulse Width (measured in JTG_TCK cycles) ²	4		T_{CK}
<i>Switching Characteristics</i>				
t_{DTDO}	JTG_TDO Delay From JTG_TCK Low		13.5	ns
t_{DSYS}	System Outputs Delay After JTG_TCK Low ³		17	ns

¹System Inputs = $\overline{MLB0_CLKP}$, $\overline{MLB0_DATP}$, $\overline{MLB0_SIGP}$, $\overline{DAI0_PIN20-01}$, $\overline{DAI1_PIN20-01}$, $\overline{DMC0_A15-0}$, $\overline{DMC1_A15-0}$, $\overline{DMC0_DQ15-0}$, $\overline{DMC1_DQ15-0}$, $\overline{DMC0_RESET}$, $\overline{DMC1_RESET}$, $\overline{PA_15-0}$, $\overline{PB_15-0}$, $\overline{PC_15-0}$, $\overline{PD_15-0}$, $\overline{PE_15-0}$, $\overline{PF_15-0}$, $\overline{PG_5-0}$, $\overline{SYS_BMODE2-0}$, $\overline{SYS_FAULT}$, $\overline{SYS_FAULT}$, $\overline{SYS_RESOUT}$, $\overline{TWI2-0_SCL}$, $\overline{TWI2-0_SDA2}$.

²50 MHz maximum.

³System Outputs = $\overline{DMC0_A15-0}$, $\overline{DMC0_BA2-0}$, $\overline{DMC0_CAS}$, $\overline{DMC0_CK}$, $\overline{DMC0_CKE}$, $\overline{DMC0_CS0}$, $\overline{DMC0_DQ15-0}$, $\overline{DMC0_LDM}$, $\overline{DMC0_LDQS}$, $\overline{DMC0_ODT}$, $\overline{DMC0_RAS}$, $\overline{DMC0_RESET}$, $\overline{DMC0_UDM}$, $\overline{DMC0_UDQS}$, $\overline{DMC0_WE}$, $\overline{DMC1_A15-0}$, $\overline{DMC1_BA2-0}$, $\overline{DMC1_CAS}$, $\overline{DMC1_CK}$, $\overline{DMC1_CKE}$, $\overline{DMC1_CS0}$, $\overline{DMC1_DQ15-0}$, $\overline{DMC1_LDM}$, $\overline{DMC1_LDQS}$, $\overline{DMC1_ODT}$, $\overline{DMC1_RAS}$, $\overline{DMC1_RESET}$, $\overline{DMC1_UDM}$, $\overline{DMC1_UDQS}$, $\overline{DMC1_WE}$, $\overline{MLB0_DATP}$, $\overline{MLB0_SIGP}$, $\overline{PA_15-0}$, $\overline{PB_15-0}$, $\overline{PC_15-0}$, $\overline{PCIE_TXP}$, $\overline{PD_15-0}$, $\overline{PE_15-0}$, $\overline{PF_15-0}$, $\overline{PG_5-0}$, $\overline{SYS_BMODE2-0}$, $\overline{SYS_CLKOUT}$, $\overline{SYS_FAULT}$, $\overline{SYS_FAULT}$, $\overline{SYS_RESOUT}$.

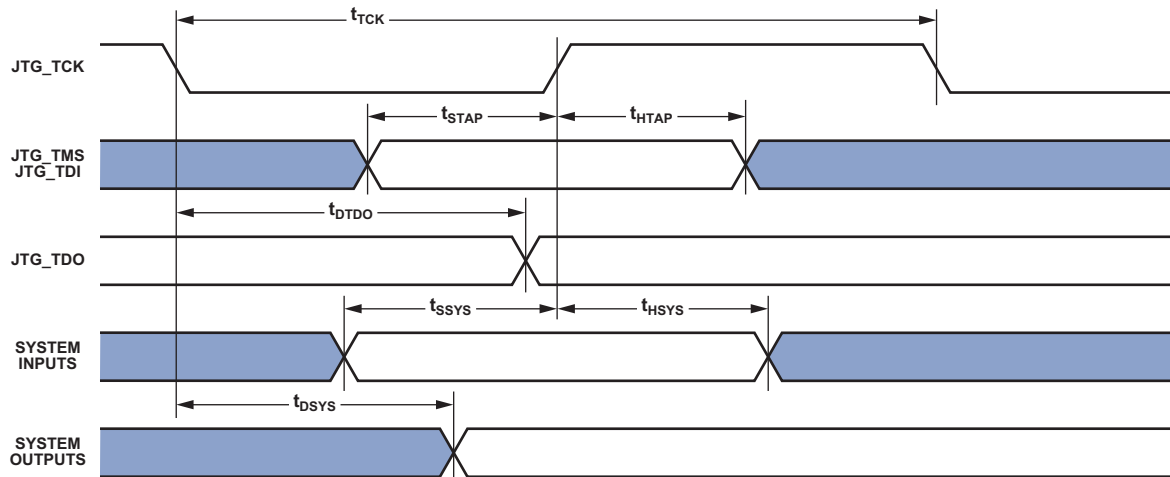

Figure 80. JTAG Port Timing

ADSP-SC582/SC583/SC584/SC587/SC589/ADSP-21583/21584/21587

OUTPUT DRIVE CURRENTS

Figure 81 through Figure 93 show typical current-voltage characteristics for the output drivers of the ADSP-SC58x and ADSP-2158x processors. The curves represent the current drive capability of the output drivers as a function of output voltage.

Output drive currents for PCIe pins are compliant with PCIe Gen1 and Gen2 x1 lane data rate specifications. Output drive currents for MLB pins are compliant with MOST150 LVDS specifications. Output drive currents for USB pins are compliant with the USB 2.0 specifications.

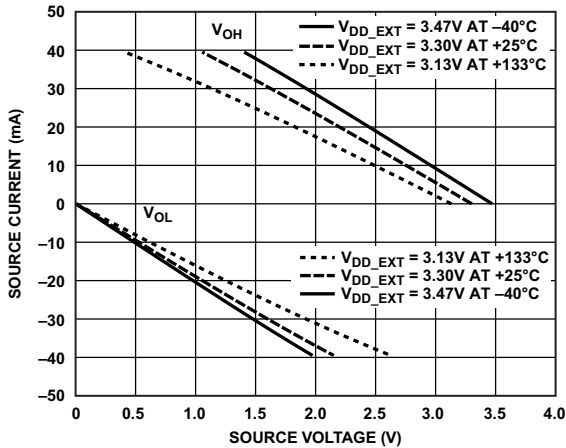

Figure 81. Driver Type A Current ($3.3 V V_{DD_EXT}$)

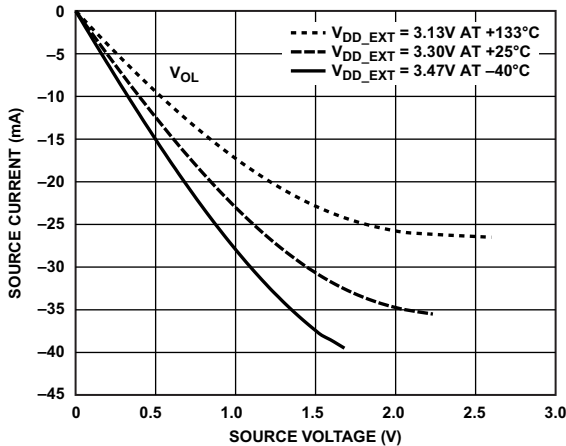

Figure 82. Driver Type D Current ($3.3 V V_{DD_EXT}$)

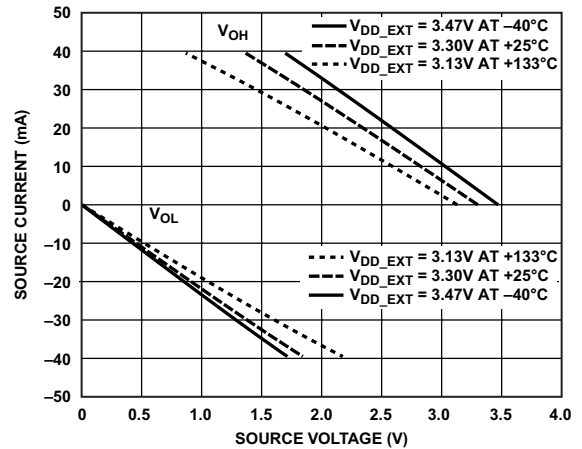

Figure 83. Driver Type H Current ($3.3 V V_{DD_EXT}$)

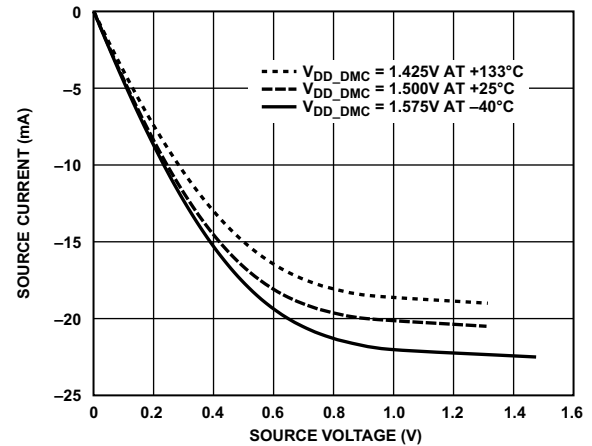

Figure 84. Driver Type B and Driver Type C (DDR3 Drive Strength 40Ω)

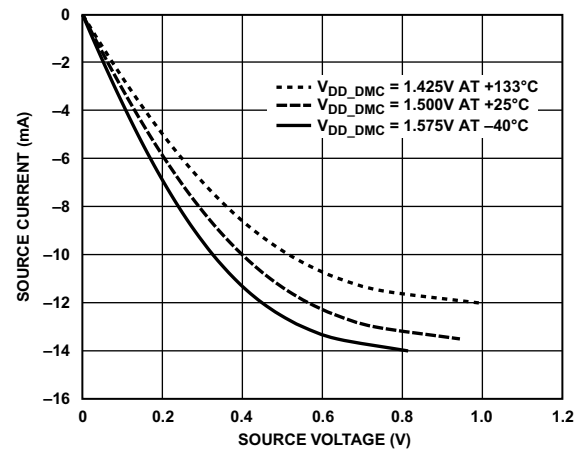

Figure 85. Driver Type B and Driver Type C (DDR3 Drive Strength 60Ω)

ADSP-SC582/SC583/SC584/SC587/SC589/ADSP-21583/21584/21587

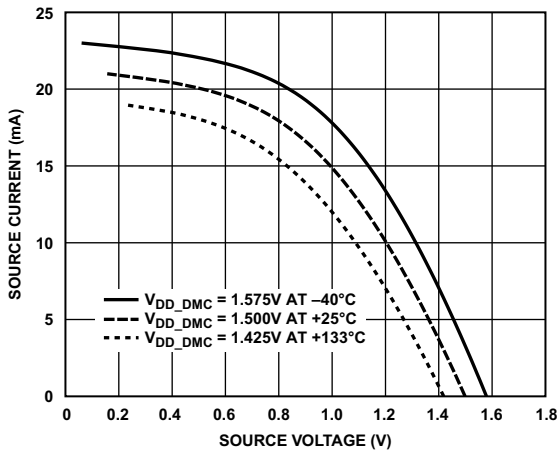

Figure 86. Driver Type B and Driver Type C (DDR3 Drive Strength 40Ω)

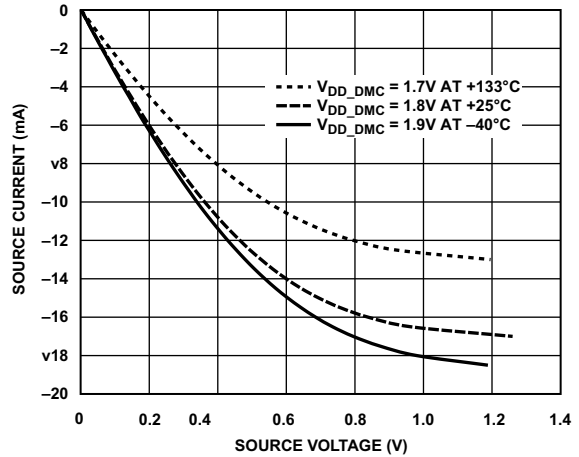

Figure 89. Driver Type B and Driver Type C (DDR2 Drive Strength 60Ω)

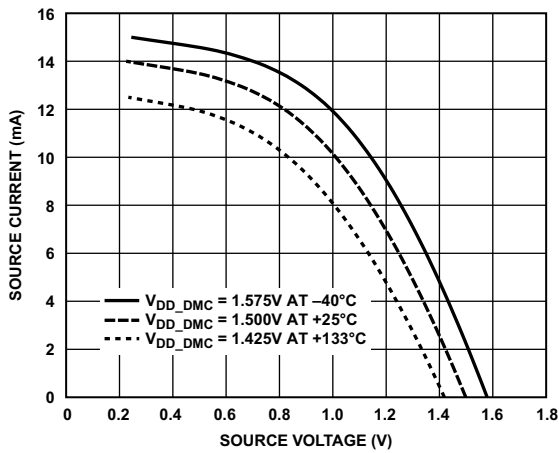

Figure 87. Driver Type B and Driver Type C (DDR3 Drive Strength 60Ω)

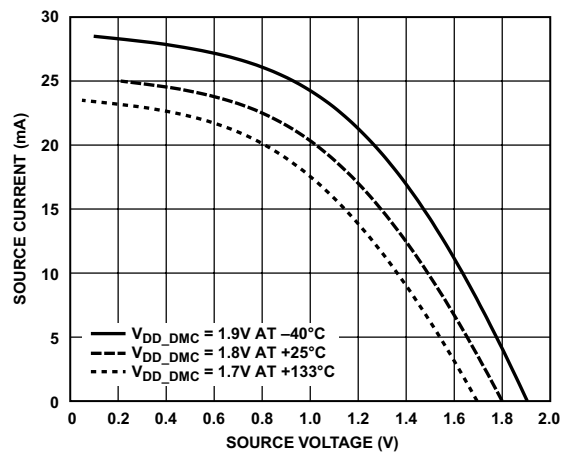

Figure 90. Driver Type B and Driver Type C (DDR2 Drive Strength 40Ω)

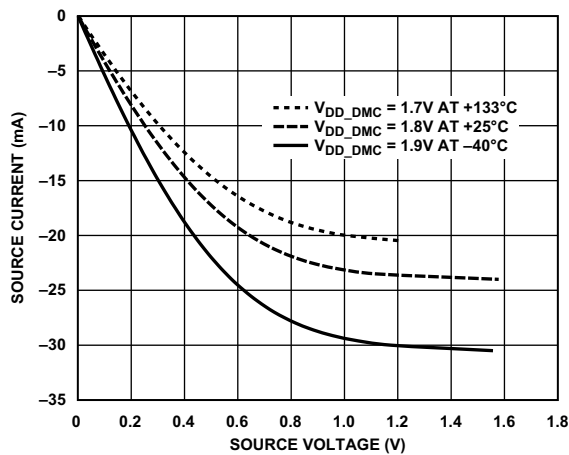

Figure 88. Driver Type B and Driver Type C (DDR2 Drive Strength 40Ω)

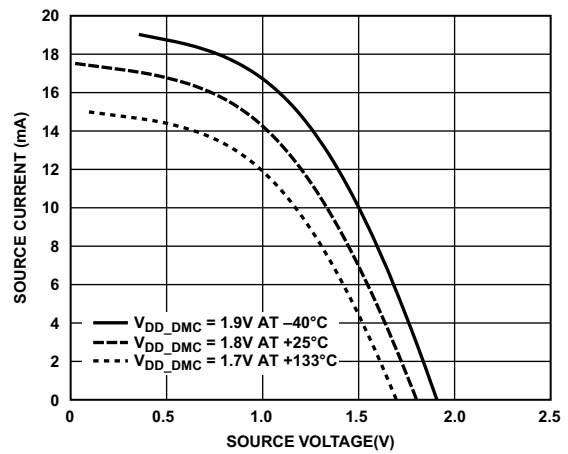

Figure 91. Driver Type B and Driver Type C (DDR2 Drive Strength 60Ω)

ADSP-SC582/SC583/SC584/SC587/SC589/ADSP-21583/21584/21587

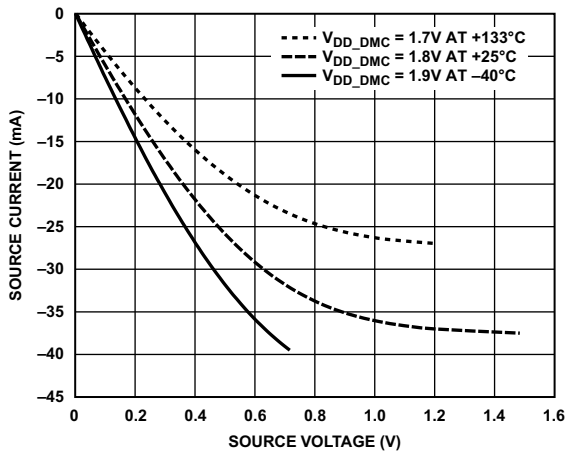

Figure 92. Driver Type B and Device Driver C (LPDDR)

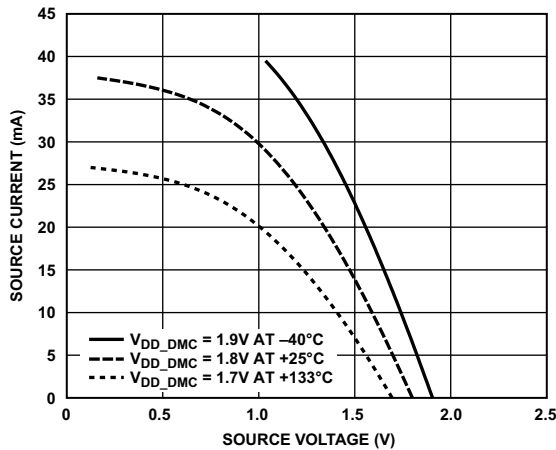

Figure 93. Driver Type B and Device Driver C (LPDDR)

TEST CONDITIONS

All timing parameters appearing in this data sheet were measured under the conditions described in this section. Figure 94 shows the measurement point for ac measurements (except output enable/disable). The measurement point, V_{MEAS} , is $V_{DD_EXT}/2$ for V_{DD_EXT} (nominal) = 3.3 V.

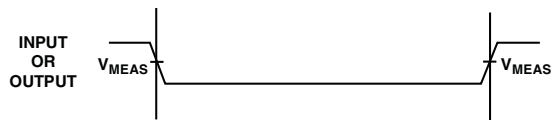

Figure 94. Voltage Reference Levels for AC Measurements (Except Output Enable/Disable)

Output Enable Time Measurement

Output pins are considered enabled when they make a transition from a high impedance state to the point when they start driving.

The output enable time, t_{ENA} , is the interval from the point when a reference signal reaches a high or low voltage level to the point when the output starts driving, as shown on the right side of Figure 95. If multiple pins are enabled, the measurement value is that of the first pin to start driving.

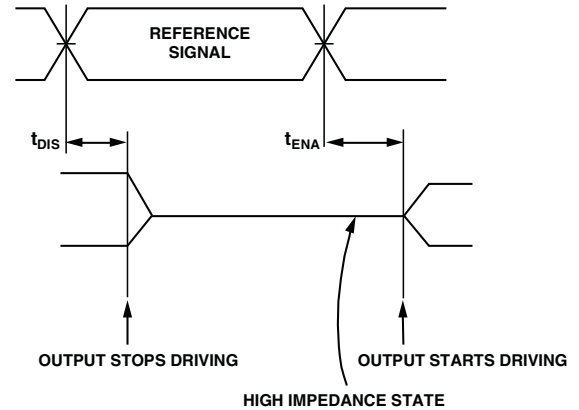

Figure 95. Output Enable/Disable

Output Disable Time Measurement

Output pins are considered disabled when they stop driving, enter a high impedance state, and start to decay from the output high or low voltage. The output disable time, t_{DIS} , is the interval from when a reference signal reaches a high or low voltage level to the point when the output stops driving, as shown on the left side of Figure 95.

Capacitive Loading

Output delays and holds are based on standard capacitive loads of an average of 6 pF on all pins (see Figure 96). V_{LOAD} is equal to $V_{DD_EXT}/2$. Figure 97 through Figure 101 show how output rise time varies with capacitance. The delay and hold specifications given must be derated by a factor derived from these figures. The graphs in these figures may not be linear outside the ranges shown.

ADSP-SC582/SC583/SC584/SC587/SC589/ADSP-21583/21584/21587

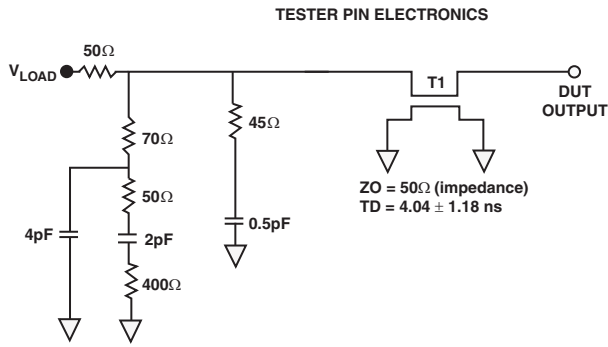

NOTES:
THE WORST CASE TRANSMISSION LINE DELAY IS SHOWN AND CAN BE USED FOR THE OUTPUT TIMING ANALYSIS TO REFLECT THE TRANSMISSION LINE EFFECT AND MUST BE CONSIDERED. THE TRANSMISSION LINE (TD) IS FOR LOAD ONLY AND DOES NOT AFFECT THE DATA SHEET TIMING SPECIFICATIONS.

ANALOG DEVICES RECOMMENDS USING THE IBIS MODEL TIMING FOR A GIVEN SYSTEM REQUIREMENT. IF NECESSARY, A SYSTEM MAY INCORPORATE EXTERNAL DRIVERS TO COMPENSATE FOR ANY TIMING DIFFERENCES.

Figure 96. Equivalent Device Loading for AC Measurements (Includes All Fixtures)

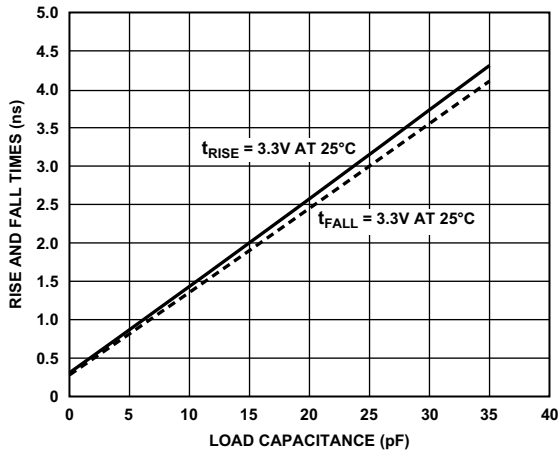

Figure 97. Driver Type A Typical Rise and Fall Times (10% to 90%) vs. Load Capacitance ($V_{DD_EXT} = 3.3\text{ V}$)

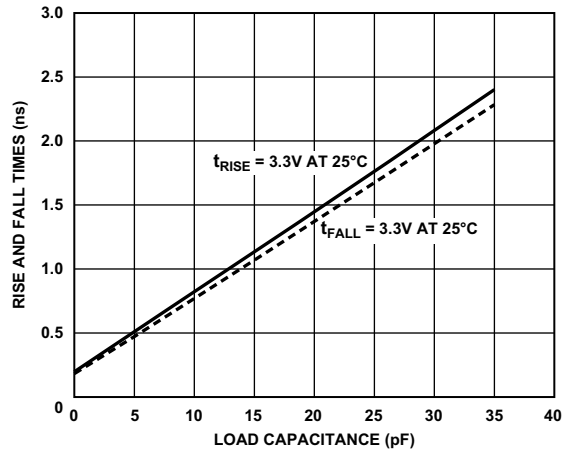

Figure 98. Driver Type H Typical Rise and Fall Times (10% to 90%) vs. Load Capacitance ($V_{DD_EXT} = 3.3\text{ V}$)

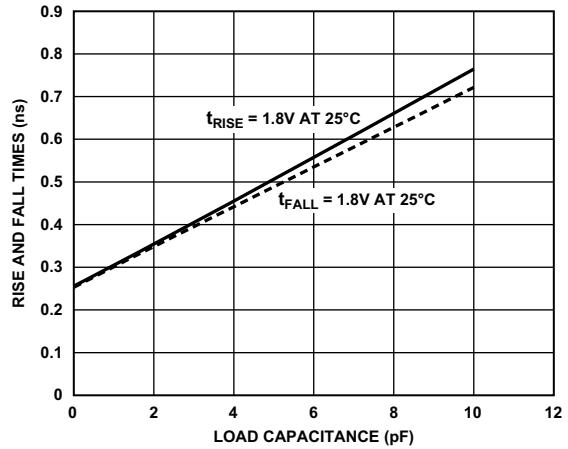

Figure 99. Driver Type B and Driver Type C Typical Rise and Fall Times (10% to 90%) vs. Load Capacitance ($V_{DD_DMC} = 1.8\text{ V}$) for LPDDR

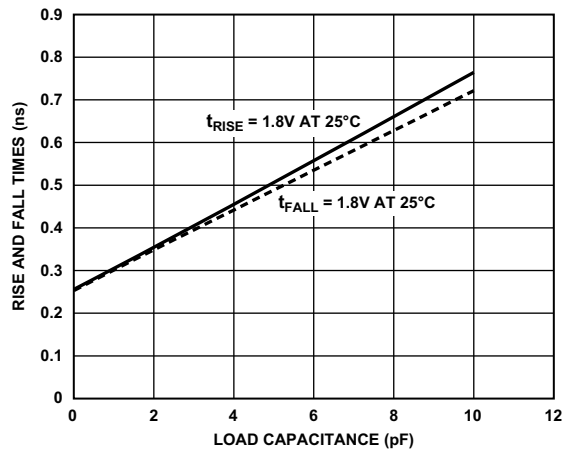

Figure 100. Driver Type B and Driver Type C Typical Rise and Fall Times (10% to 90%) vs. Load Capacitance ($V_{DD_DMC} = 1.8\text{ V}$) for DDR2

ADSP-SC582/SC583/SC584/SC587/SC589/ADSP-21583/21584/21587

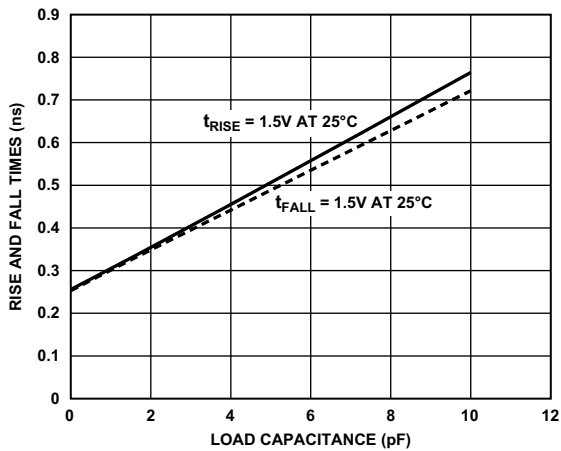

Figure 101. Driver Type B and Driver Type C Typical Rise and Fall Times (10% to 90%) vs. Load Capacitance ($V_{DD_DMC} = 1.5\text{ V}$) for DDR3

ENVIRONMENTAL CONDITIONS

To determine the junction temperature on the application PCB, use the following equation:

$$T_J = T_{CASE} + (\Psi_{JT} \times P_D)$$

where:

T_J = junction temperature ($^{\circ}\text{C}$).

T_{CASE} = case temperature ($^{\circ}\text{C}$) measured at top center of package.

Ψ_{JT} = from [Table 107](#) and [Table 108](#).

P_D = power dissipation (see the [Total Internal Power Dissipation](#) section for the method to calculate P_D).

Values of θ_{JA} are provided for package comparison and PCB design considerations. θ_{JA} can be used for a first order approximation of T_J by the following equation:

$$T_J = T_A + (\theta_{JA} \times P_D)$$

where T_A = ambient temperature ($^{\circ}\text{C}$).

Values of θ_{JC} are provided for package comparison and PCB design considerations when an external heat sink is required.

In [Table 107](#) and [Table 108](#), airflow measurements comply with JEDEC standards JESD51-2 and JESD51-6. The junction to case measurement complies with MIL-STD-883 (Method 1012.1).

All measurements use a 6-layer PCB with 101.6 mm \times 152.4 mm dimensions.

Table 107. Thermal Characteristics for 349 CSP_BGA

Parameter	Conditions	Typ	Unit
θ_{JA}	0 linear m/s air flow	13.3	$^{\circ}\text{C}/\text{W}$
θ_{JA}	1 linear m/s air flow	12.1	$^{\circ}\text{C}/\text{W}$
θ_{JA}	2 linear m/s air flow	11.6	$^{\circ}\text{C}/\text{W}$
θ_{JC}		3.65	$^{\circ}\text{C}/\text{W}$
Ψ_{JT}	0 linear m/s air flow	0.08	$^{\circ}\text{C}/\text{W}$
Ψ_{JT}	1 linear m/s air flow	0.12	$^{\circ}\text{C}/\text{W}$
Ψ_{JT}	2 linear m/s air flow	0.14	$^{\circ}\text{C}/\text{W}$

Table 108. Thermal Characteristics for 529 CSP_BGA

Parameter	Conditions	Typ	Unit
θ_{JA}	0 linear m/s air flow	13.4	$^{\circ}\text{C}/\text{W}$
θ_{JA}	1 linear m/s air flow	12.1	$^{\circ}\text{C}/\text{W}$
θ_{JA}	2 linear m/s air flow	11.6	$^{\circ}\text{C}/\text{W}$
θ_{JC}		3.63	$^{\circ}\text{C}/\text{W}$
Ψ_{JT}	0 linear m/s air flow	0.08	$^{\circ}\text{C}/\text{W}$
Ψ_{JT}	1 linear m/s air flow	0.11	$^{\circ}\text{C}/\text{W}$
Ψ_{JT}	2 linear m/s air flow	0.13	$^{\circ}\text{C}/\text{W}$

ADSP-SC582/SC583/SC584/SC587/SC589/ADSP-21583/21584/21587

ADSP-SC58x/ADSP-2158x 349-BALL BGA BALL ASSIGNMENTS

The ADSP-SC58x/ADSP-2158x 349-Ball BGA Ball Assignments (Numerical by Ball Number) table lists the 349-ball BGA package by ball number.

The ADSP-SC58x/ADSP-2158x 349-Ball BGA Ball Assignments (Alphabetical by Pin Name) table lists the 349-ball BGA package by pin name.

ADSP-SC58x/ADSP-2158x 349-BALL BGA BALL ASSIGNMENTS (NUMERICAL BY BALL NUMBER)

Ball No.	Pin Name	Ball No.	Pin Name	Ball No.	Pin Name	Ball No.	Pin Name
A01	GND	B20	PD_05	F02	PC_11	H17	VDD_DMC
A02	DMC0_A06	B21	GND	F03	DMC0_BA1	H20	VDD_INT
A03	DMC0_A04	B22	PD_08	F06	VDD_DMC	H21	PE_03
A04	DMC0_RA5	C01	DMC0_A10	F07	VDD_INT	H22	PE_04
A05	DMC0_CKE	C02	DMC0_A09	F08	VDD_INT	J01	PC_05
A06	DMC0_DQ15	C03	GND	F09	VDD_INT	J02	PC_06
A07	DMC0_DQ13	C04	DMC0_A08	F10	VDD_INT	J03	JTG_TDI
A08	DMC0_UDQS	C05	DMC0_A03	F11	VDD_DMC	J06	VDD_DMC
A09	DMC0_UDQS	C06	DMC0_CA5	F12	VDD_INT	J09	GND
A10	DMC0_DQ09	C07	DMC0_BA0	F13	VDD_INT	J10	GND
A11	DMC0_VREF	C08	DMC0_A01	F14	VDD_INT	J11	GND
A12	DMC0_CK	C09	DMC0_RZQ	F15	VDD_INT	J12	GND
A13	DMC0_CK	C10	DMC0_WE	F16	VDD_INT	J13	GND
A14	DMC0_DQ06	C11	DMC0_CS0	F17	VDD_INT	J14	GND
A15	DMC0_LDQS	C12	GND	F20	VDD_INT	J17	VDD_EXT
A16	DMC0_LDQS	C13	DMC0_LDM	F21	PD_15	J20	VDD_INT
A17	DMC0_DQ01	C14	DMC0_UDM	F22	PE_00	J21	PE_05
A18	GND	C15	PD_01	G01	PC_12	J22	PE_06
A19	PD_00	C16	PC_14	G02	PC_10	K01	PC_03
A20	PD_03	C17	SYS_CLKOUT	G03	PC_04	K02	PC_02
A21	PD_06	C18	PC_15	G06	VDD_DMC	K03	SYS_FAULT
A22	GND	C19	PD_04	G07	VDD_DMC	K06	VDD_INT
B01	DMC0_A07	C20	GND	G08	VDD_DMC	K08	GND
B02	GND	C21	PD_07	G09	VDD_DMC	K09	GND
B03	DMC0_A02	C22	PD_11	G10	VDD_DMC	K10	GND
B04	DMC0_A00	D01	DMC0_A11	G11	VDD_DMC	K11	GND
B05	DMC0_ODT	D02	DMC0_A12	G12	VDD_DMC	K12	GND
B06	DMC0_DQ14	D03	DMC0_BA2	G13	VDD_DMC	K13	GND
B07	DMC0_DQ12	D11	VDD_INT	G14	VDD_DMC	K14	GND
B08	GND	D12	VDD_INT	G15	VDD_DMC	K15	GND
B09	DMC0_DQ11	D20	PD_10	G16	VDD_DMC	K17	VDD_EXT
B10	DMC0_DQ10	D21	PD_09	G17	VDD_DMC	K20	VDD_INT
B11	DMC0_DQ08	D22	PD_12	G20	VDD_INT	K21	PE_08
B12	DMC0_DQ07	E01	DMC0_A14	G21	PE_01	K22	PE_07
B13	DMC0_DQ05	E02	DMC0_A15	G22	PE_02	L01	PC_01
B14	DMC0_DQ04	E03	DMC0_A13	H01	PC_08	L02	SYS_HWRST
B15	DMC0_DQ03	E05	DMC0_A05	H02	PC_07	L03	PC_09
B16	DMC0_DQ02	E20	VDD_INT	H03	SYS_FAULT	L04	VDD_INT
B17	DMC0_DQ00	E21	PD_13	H06	VDD_DMC	L06	VDD_INT
B18	PC_13	E22	PD_14	H07	VDD_DMC	L08	GND
B19	PD_02	F01	DMC0_RESET	H16	GND	L09	GND

ADSP-SC582/SC583/SC584/SC587/SC589/ADSP-21583/21584/21587

Ball No.	Pin Name	Ball No.	Pin Name	Ball No.	Pin Name	Ball No.	Pin Name
L10	GND	P03	JTG_TDO	U10	VDD_INT	AA01	DAI0_PIN11
L11	GND	P06	VDD_EXT	U11	VDD_INT	AA02	GND
L12	GND	P09	GND	U12	VDD_INT	AA03	DAI0_PIN10
L13	GND	P10	GND	U13	VDD_INT	AA04	DAI0_PIN04
L14	GND	P11	GND	U14	VDD_EXT	AA05	DAI0_PIN05
L15	GND	P12	GND	U15	VDD_EXT	AA06	USB0_ID
L17	VDD_EXT	P13	GND	U16	VDD_EXT	AA07	USB0_VBUS
L19	VDD_INT	P14	GND	U17	VDD_EXT	AA08	TWI2_SCL
L20	PE_11	P17	VDD_EXT	U20	DAI1_PIN20	AA09	TWI2_SDA
L21	PE_10	P20	DAI1_PIN01	U21	DAI1_PIN11	AA10	TWI0_SDA
L22	PE_09	P21	DAI1_PIN05	U22	DAI1_PIN19	AA11	HADC0_VIN2
M01	JTG_TRST	P22	DAI1_PIN03	V01	PB_13	AA12	HADC0_VIN5
M02	JTG_TMS	R01	GND	V02	PB_12	AA13	HADC0_VIN4
M03	JTG_TCK	R02	PB_15	V03	DAI0_PIN20	AA14	HADC0_VIN7
M04	VDD_INT	R03	PB_14	V20	PA_00	AA15	PB_05
M06	VDD_INT	R06	VDD_EXT	V21	PA_01	AA16	PB_02
M08	GND	R07	GND	V22	PA_02	AA17	PA_14
M09	GND	R16	GND	W01	PB_10	AA18	PB_03
M10	GND	R17	VDD_EXT	W02	PB_11	AA19	PA_12
M11	GND	R20	DAI1_PIN08	W03	DAI0_PIN19	AA20	PA_11
M12	GND	R21	DAI1_PIN07	W11	VDD_INT	AA21	GND
M13	GND	R22	DAI1_PIN06	W12	VDD_INT	AA22	PA_09
M14	GND	T01	SYS_XTAL0	W20	PA_05	AB01	GND
M15	GND	T02	SYS_BMODE2	W21	PA_03	AB02	DAI0_PIN09
M17	VDD_EXT	T03	DAI0_PIN07	W22	PA_04	AB03	DAI0_PIN08
M19	VDD_INT	T06	VDD_EXT	Y01	PB_09	AB04	USB_CLKIN
M20	PE_13	T07	GND	Y02	PB_08	AB05	USB_XTAL
M21	PE_15	T08	GND	Y03	DAI0_PIN12	AB06	USB0_DP
M22	PE_12	T09	GND	Y04	DAI0_PIN06	AB07	USB0_DM
N01	SYS_XTAL1	T10	GND	Y05	DAI0_PIN02	AB08	TWI1_SCL
N02	SYS_BMODE0	T11	GND	Y06	DAI0_PIN03	AB09	HADC0_VREFP
N03	PC_00	T12	GND	Y07	DAI0_PIN01	AB10	HADC0_VREFN
N06	VDD_EXT	T13	GND	Y08	USB0_VBC	AB11	HADC0_VIN0
N08	GND	T14	GND	Y09	TWI0_SCL	AB12	HADC0_VIN1
N09	GND	T15	GND	Y10	TWI1_SDA	AB13	HADC0_VIN3
N10	GND	T16	GND	Y11	VDD_HADC	AB14	MLB0_SIGP
N11	GND	T17	VDD_EXT	Y12	GND	AB15	MLB0_SIGN
N12	GND	T20	DAI1_PIN12	Y13	HADC0_VIN6	AB16	MLB0_DATP
N13	GND	T21	DAI1_PIN10	Y14	PB_06	AB17	MLB0_DATN
N14	GND	T22	DAI1_PIN09	Y15	PB_00	AB18	MLB0_CLKP
N15	GND	U01	SYS_CLKIN0	Y16	PB_04	AB19	MLB0_CLKN
N17	VDD_EXT	U02	SYS_RESOUT	Y17	PB_01	AB20	PA_13
N20	DAI1_PIN04	U03	PB_07	Y18	PA_10	AB21	PA_07
N21	DAI1_PIN02	U06	VDD_EXT	Y19	PA_15	AB22	GND
N22	PE_14	U07	VDD_EXT	Y20	GND		
P01	SYS_CLKIN1	U08	VDD_USB	Y21	PA_06		
P02	SYS_BMODE1	U09	VDD_INT	Y22	PA_08		

ADSP-SC582/SC583/SC584/SC587/SC589/ADSP-21583/21584/21587

ADSP-SC58x/ADSP-2158x 349-BALL BGA BALL ASSIGNMENTS (ALPHABETICAL BY PIN NAME)

Pin Name	Ball No.	Pin Name	Ball No.	Pin Name	Ball No.	Pin Name	Ball No.
DAIO_PIN01	Y07	DMC0_CAS	C06	GND	J09	GND	T07
DAIO_PIN02	Y05	DMC0_CK	A13	GND	J10	GND	T08
DAIO_PIN03	Y06	DMC0_CKE	A05	GND	J11	GND	T09
DAIO_PIN04	AA04	DMC0_CK	A12	GND	J12	GND	T10
DAIO_PIN05	AA05	DMC0_CS0	C11	GND	J13	GND	T11
DAIO_PIN06	Y04	DMC0_DQ00	B17	GND	J14	GND	T12
DAIO_PIN07	T03	DMC0_DQ01	A17	GND	K08	GND	T13
DAIO_PIN08	AB03	DMC0_DQ02	B16	GND	K09	GND	T14
DAIO_PIN09	AB02	DMC0_DQ03	B15	GND	K10	GND	T15
DAIO_PIN10	AA03	DMC0_DQ04	B14	GND	K11	GND	T16
DAIO_PIN11	AA01	DMC0_DQ05	B13	GND	K12	GND	Y12
DAIO_PIN12	Y03	DMC0_DQ06	A14	GND	K13	GND	Y20
DAIO_PIN19	W03	DMC0_DQ07	B12	GND	K14	HADC0_VIN0	AB11
DAIO_PIN20	V03	DMC0_DQ08	B11	GND	K15	HADC0_VIN1	AB12
DAI1_PIN01	P20	DMC0_DQ09	A10	GND	L08	HADC0_VIN2	AA11
DAI1_PIN02	N21	DMC0_DQ10	B10	GND	L09	HADC0_VIN3	AB13
DAI1_PIN03	P22	DMC0_DQ11	B09	GND	L10	HADC0_VIN4	AA13
DAI1_PIN04	N20	DMC0_DQ12	B07	GND	L11	HADC0_VIN5	AA12
DAI1_PIN05	P21	DMC0_DQ13	A07	GND	L12	HADC0_VIN6	Y13
DAI1_PIN06	R22	DMC0_DQ14	B06	GND	L13	HADC0_VIN7	AA14
DAI1_PIN07	R21	DMC0_DQ15	A06	GND	L14	HADC0_VREFN	AB10
DAI1_PIN08	R20	DMC0_LDM	C13	GND	L15	HADC0_VREFP	AB09
DAI1_PIN09	T22	DMC0_LDQS	A16	GND	M08	JTG_TCK	M03
DAI1_PIN10	T21	DMC0_LDQS	A15	GND	M09	JTG_TDI	J03
DAI1_PIN11	U21	DMC0_ODT	B05	GND	M10	JTG_TDO	P03
DAI1_PIN12	T20	DMC0_RAS	A04	GND	M11	JTG_TMS	M02
DAI1_PIN19	U22	DMC0_RESET	F01	GND	M12	JTG_TRST	M01
DAI1_PIN20	U20	DMC0_RZQ	C09	GND	M13	MLB0_CLKN	AB19
DMC0_A00	B04	DMC0_UDM	C14	GND	M14	MLB0_CLKP	AB18
DMC0_A01	C08	DMC0_UDQS	A09	GND	M15	MLB0_DATN	AB17
DMC0_A02	B03	DMC0_UDQS	A08	GND	N08	MLB0_DATP	AB16
DMC0_A03	C05	DMC0_VREF	A11	GND	N09	MLB0_SIGN	AB15
DMC0_A04	A03	DMC0_WE	C10	GND	N10	MLB0_SIGP	AB14
DMC0_A05	E05	GND	A01	GND	N11	PA_00	V20
DMC0_A06	A02	GND	A18	GND	N12	PA_01	V21
DMC0_A07	B01	GND	A22	GND	N13	PA_02	V22
DMC0_A08	C04	GND	AA02	GND	N14	PA_03	W21
DMC0_A09	C02	GND	AA21	GND	N15	PA_04	W22
DMC0_A10	C01	GND	AB01	GND	P09	PA_05	W20
DMC0_A11	D01	GND	AB22	GND	P10	PA_06	Y21
DMC0_A12	D02	GND	B02	GND	P11	PA_07	AB21
DMC0_A13	E03	GND	B08	GND	P12	PA_08	Y22
DMC0_A14	E01	GND	B21	GND	P13	PA_09	AA22
DMC0_A15	E02	GND	C03	GND	P14	PA_10	Y18
DMC0_BA0	C07	GND	C12	GND	R01	PA_11	AA20
DMC0_BA1	F03	GND	C20	GND	R07	PA_12	AA19
DMC0_BA2	D03	GND	H16	GND	R16	PA_13	AB20

ADSP-SC582/SC583/SC584/SC587/SC589/ADSP-21583/21584/21587

Pin Name	Ball No.	Pin Name	Ball No.	Pin Name	Ball No.	Pin Name	Ball No.
PA_14	AA17	PD_14	E22	VDD_DMC	G09	VDD_INT	J20
PA_15	Y19	PD_15	F21	VDD_DMC	G10	VDD_INT	K06
PB_00	Y15	PE_00	F22	VDD_DMC	G11	VDD_INT	K20
PB_01	Y17	PE_01	G21	VDD_DMC	G12	VDD_INT	L04
PB_02	AA16	PE_02	G22	VDD_DMC	G13	VDD_INT	L06
PB_03	AA18	PE_03	H21	VDD_DMC	G14	VDD_INT	L19
PB_04	Y16	PE_04	H22	VDD_DMC	G15	VDD_INT	M04
PB_05	AA15	PE_05	J21	VDD_DMC	G16	VDD_INT	M06
PB_06	Y14	PE_06	J22	VDD_DMC	G17	VDD_INT	M19
PB_07	U03	PE_07	K22	VDD_DMC	H06	VDD_INT	U09
PB_08	Y02	PE_08	K21	VDD_DMC	H07	VDD_INT	U10
PB_09	Y01	PE_09	L22	VDD_DMC	H17	VDD_INT	U11
PB_10	W01	PE_10	L21	VDD_DMC	J06	VDD_INT	U12
PB_11	W02	PE_11	L20	VDD_EXT	J17	VDD_INT	U13
PB_12	V02	PE_12	M22	VDD_EXT	K17	VDD_INT	W11
PB_13	V01	PE_13	M20	VDD_EXT	L17	VDD_INT	W12
PB_14	R03	PE_14	N22	VDD_EXT	M17	VDD_USB	U08
PB_15	R02	PE_15	M21	VDD_EXT	N06		
PC_00	N03	SYS_BMODE0	N02	VDD_EXT	N17		
PC_01	L01	SYS_BMODE1	P02	VDD_EXT	P06		
PC_02	K02	SYS_BMODE2	T02	VDD_EXT	P17		
PC_03	K01	SYS_CLKIN0	U01	VDD_EXT	R06		
PC_04	G03	SYS_CLKIN1	P01	VDD_EXT	R17		
PC_05	J01	SYS_CLKOUT	C17	VDD_EXT	T06		
PC_06	J02	SYS_FAULT	H03	VDD_EXT	T17		
PC_07	H02	SYS_FAULT	K03	VDD_EXT	U06		
PC_08	H01	SYS_HWRST	L02	VDD_EXT	U07		
PC_09	L03	SYS_RESOUT	U02	VDD_EXT	U14		
PC_10	G02	SYS_XTAL0	T01	VDD_EXT	U15		
PC_11	F02	SYS_XTAL1	N01	VDD_EXT	U16		
PC_12	G01	TWI0_SCL	Y09	VDD_EXT	U17		
PC_13	B18	TWI0_SDA	AA10	VDD_HADC	Y11		
PC_14	C16	TWI1_SCL	AB08	VDD_INT	D11		
PC_15	C18	TWI1_SDA	Y10	VDD_INT	D12		
PD_00	A19	TWI2_SCL	AA08	VDD_INT	E20		
PD_01	C15	TWI2_SDA	AA09	VDD_INT	F07		
PD_02	B19	USB0_DM	AB07	VDD_INT	F08		
PD_03	A20	USB0_DP	AB06	VDD_INT	F09		
PD_04	C19	USB0_ID	AA06	VDD_INT	F10		
PD_05	B20	USB0_VBC	Y08	VDD_INT	F12		
PD_06	A21	USB0_VBUS	AA07	VDD_INT	F13		
PD_07	C21	USB_CLKIN	AB04	VDD_INT	F14		
PD_08	B22	USB_XTAL	AB05	VDD_INT	F15		
PD_09	D21	VDD_DMC	F06	VDD_INT	F16		
PD_10	D20	VDD_DMC	F11	VDD_INT	F17		
PD_11	C22	VDD_DMC	G06	VDD_INT	F20		
PD_12	D22	VDD_DMC	G07	VDD_INT	G20		
PD_13	E21	VDD_DMC	G08	VDD_INT	H20		

ADSP-SC582/SC583/SC584/SC587/SC589/ADSP-21583/21584/21587

CONFIGURATION OF THE 349-BALL CSP_BGA

Figure 102 shows an overview of signal placement on the 349-ball CSP_BGA.

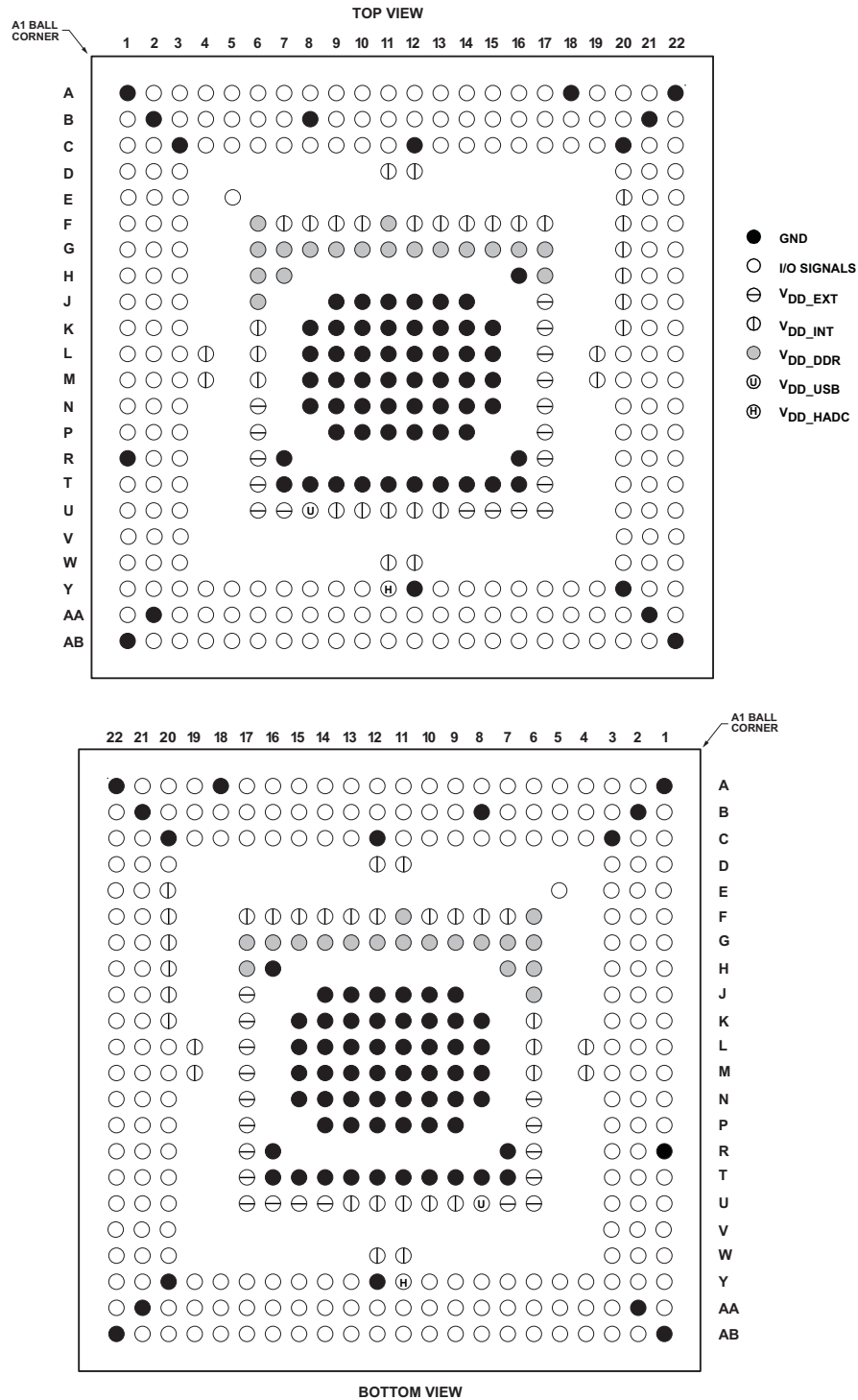

Figure 102. 349-Ball CSP_BGA Configuration

ADSP-SC582/SC583/SC584/SC587/SC589/ADSP-21583/21584/21587

ADSP-SC58x/ADSP-2158x 529-BALL BGA BALL ASSIGNMENTS

The ADSP-SC58x/ADSP-2158x 529-Ball BGA Ball Assignments (Numerical by Ball Number) table lists the 529-ball BGA package by ball number.

The ADSP-SC58x/ADSP-2158x 529-Ball BGA Ball Assignments (Alphabetical by Pin Name) table lists the 529-ball BGA package by pin name.

ADSP-SC58x/ADSP-2158x 529-BALL BGA BALL ASSIGNMENTS (NUMERICAL BY BALL NUMBER)

Ball No.	Pin Name	Ball No.	Pin Name	Ball No.	Pin Name	Ball No.	Pin Name
A01	GND	B19	DMC1_DQ11	D14	DMC1_BA2	F09	GND
A02	$\overline{\text{DMC0_UDQS}}$	B20	DMC1_DQ12	D15	$\overline{\text{DMC1_CAS}}$	F10	VDD_INT
A03	$\overline{\text{DMC0_CK}}$	B21	DMC1_DQ14	D16	$\overline{\text{DMC1_RAS}}$	F11	VDD_INT
A04	DMC0_CK	B22	PD_00	D17	DMC1_A09	F12	VDD_INT
A05	DMC0_DQ09	B23	PD_04	D18	DMC1_A15	F13	VDD_INT
A06	$\overline{\text{DMC0_LDQS}}$	C01	DMC0_DQ14	D19	DMC1_A10	F14	VDD_INT
A07	DMC0_LDQS	C02	DMC0_DQ13	D20	DMC1_A11	F15	VDD_INT
A08	DMC0_DQ05	C03	$\overline{\text{DMC0_CS0}}$	D21	PC_14	F16	GND
A09	DMC0_DQ03	C04	DMC0_CKE	D22	PD_10	F17	VDD_INT
A10	DMC0_DQ01	C05	DMC0_LDM	D23	PD_09	F18	VDD_INT
A11	DMC1_DQ03	C06	$\overline{\text{DMC1_RESET}}$	E01	DMC0_A04	F19	VDD_INT
A12	DMC1_DQ00	C07	DMC1_A03	E02	$\overline{\text{DMC0_RAS}}$	F20	PE_06
A13	DMC1_LDQS	C08	DMC1_A00	E03	DMC0_BA1	F21	PD_02
A14	$\overline{\text{DMC1_LDQS}}$	C09	DMC1_A01	E04	$\overline{\text{DMC0_WE}}$	F22	PD_13
A15	DMC1_VREF	C10	DMC1_A04	E05	DMC0_RZQ	F23	PD_12
A16	DMC1_CK	C11	DMC1_A06	E06	GND	G01	DMC0_A13
A17	$\overline{\text{DMC1_CK}}$	C12	DMC1_BA1	E07	GND	G02	DMC0_A09
A18	DMC1_DQ09	C13	DMC1_ODT	E08	GND	G03	DMC0_A03
A19	$\overline{\text{DMC1_UDQS}}$	C14	$\overline{\text{DMC1_CS0}}$	E09	GND	G04	DMC0_A11
A20	DMC1_UDQS	C15	DMC1_LDM	E10	VDD_INT	G05	VDD_INT
A21	DMC1_DQ13	C16	DMC1_UDM	E11	VDD_INT	G06	VDD_DMC
A22	DMC1_DQ15	C17	DMC1_A14	E12	VDD_INT	G07	VDD_DMC
A23	GND	C18	DMC1_A12	E13	VDD_INT	G08	VDD_DMC
B01	DMC0_UDQS	C19	DMC1_A13	E14	VDD_INT	G09	VDD_DMC
B02	DMC0_DQ12	C20	PC_13	E15	VDD_INT	G10	VDD_DMC
B03	DMC0_DQ11	C21	PD_01	E16	VDD_INT	G11	VDD_DMC
B04	DMC0_DQ10	C22	PD_06	E17	VDD_INT	G12	VDD_DMC
B05	DMC0_DQ08	C23	PD_05	E18	VDD_INT	G13	VDD_DMC
B06	DMC0_DQ06	D01	DMC0_VREF	E19	DMC1_RZQ	G14	VDD_DMC
B07	DMC0_DQ07	D02	DMC0_DQ15	E20	PC_15	G15	VDD_DMC
B08	DMC0_DQ04	D03	DMC0_BA0	E21	PD_08	G16	VDD_DMC
B09	DMC0_DQ02	D04	DMC0_BA2	E22	PD_14	G17	VDD_DMC
B10	DMC0_DQ00	D05	DMC0_ODT	E23	PD_11	G18	VDD_DMC
B11	DMC1_DQ01	D06	DMC0_UDM	F01	DMC0_A01	G19	VDD_INT
B12	DMC1_DQ02	D07	DMC1_A05	F02	DMC0_A06	G20	PE_04
B13	DMC1_DQ04	D08	$\overline{\text{DMC1_WE}}$	F03	$\overline{\text{DMC0_CAS}}$	G21	PE_13
B14	DMC1_DQ05	D09	DMC1_A07	F04	DMC0_A02	G22	PE_01
B15	DMC1_DQ06	D10	DMC1_A02	F05	DMC0_A07	G23	PE_00
B16	DMC1_DQ07	D11	DMC1_BA0	F06	GND	H01	DMC0_A14
B17	DMC1_DQ08	D12	DMC1_A08	F07	VDD_INT	H02	DMC0_A12
B18	DMC1_DQ10	D13	DMC1_CKE	F08	VDD_INT	H03	DMC0_A05

ADSP-SC582/SC583/SC584/SC587/SC589/ADSP-21583/21584/21587

Ball No.	Pin Name	Ball No.	Pin Name	Ball No.	Pin Name	Ball No.	Pin Name
H04	DMCO_A00	K05	VDD_INT	M06	VDD_DMC	P07	GND
H05	VDD_INT	K06	VDD_DMC	M07	GND	P08	GND
H06	VDD_DMC	K07	GND	M08	GND	P09	GND
H07	VDD_DMC	K08	GND	M09	GND	P10	GND
H08	VDD_DMC	K09	GND	M10	GND	P11	GND
H09	VDD_DMC	K10	GND	M11	GND	P12	GND
H10	VDD_DMC	K11	GND	M12	GND	P13	GND
H11	VDD_DMC	K12	GND	M13	GND	P14	GND
H12	VDD_DMC	K13	GND	M14	GND	P15	GND
H13	VDD_DMC	K14	GND	M15	GND	P16	GND
H14	VDD_DMC	K15	GND	M16	GND	P17	GND
H15	VDD_DMC	K16	GND	M17	GND	P18	VDD_EXT
H16	VDD_DMC	K17	GND	M18	VDD_EXT	P19	PF_10
H17	VDD_DMC	K18	VDD_EXT	M19	PE_08	P20	PF_08
H18	VDD_DMC	K19	VDD_INT	M20	PE_11	P21	PF_15
H19	VDD_INT	K20	PD_15	M21	PF_03	P22	PF_12
H20	SYS_CLKOUT	K21	PF_11	M22	PF_00	P23	PG_00
H21	PE_12	K22	PF_06	M23	PF_02	R01	SYS_XTAL1
H22	PE_05	K23	PE_10	N01	JTG_TMS	R02	SYS_BMODE1
H23	PE_02	L01	PC_04	N02	JTG_TRST	R03	SYS_BMODE2
J01	DMCO_A15	L02	PC_12	N03	SYS_HWRST	R04	SYS_BMODE0
J02	DMCO_A10	L03	PC_07	N04	PC_03	R05	VDD_INT
J03	DMCO_A08	L04	PC_10	N05	VDD_INT	R06	VDD_EXT
J04	PC_08	L05	VDD_INT	N06	VDD_EXT	R07	GND
J05	VDD_INT	L06	VDD_DMC	N07	GND	R08	GND
J06	VDD_DMC	L07	GND	N08	GND	R09	GND
J07	GND	L08	GND	N09	GND	R10	GND
J08	GND	L09	GND	N10	GND	R11	GND
J09	GND	L10	GND	N11	GND	R12	GND
J10	GND	L11	GND	N12	GND	R13	GND
J11	GND	L12	GND	N13	GND	R14	GND
J12	GND	L13	GND	N14	GND	R15	GND
J13	GND	L14	GND	N15	GND	R16	GND
J14	GND	L15	GND	N16	GND	R17	GND
J15	GND	L16	GND	N17	GND	R18	VDD_EXT
J16	GND	L17	GND	N18	VDD_EXT	R19	VDD_INT
J17	GND	L18	VDD_EXT	N19	VDD_INT	R20	PG_01
J18	VDD_EXT	L19	VDD_INT	N20	PE_15	R21	PG_05
J19	PD_03	L20	PE_03	N21	PF_04	R22	PG_04
J20	PD_07	L21	PF_09	N22	PF_05	R23	PF_13
J21	PF_14	L22	PE_09	N23	PF_07	T01	SYS_CLKIN1
J22	PF_01	L23	PE_14	P01	JTG_TDO	T02	PB_15
J23	PE_07	M01	PC_01	P02	JTG_TDI	T03	GND
K01	DMCO_RESET	M02	PC_05	P03	SYS_FAULT	T04	PB_14
K02	PC_11	M03	PC_02	P04	JTG_TCK	T05	VDD_INT
K03	PC_06	M04	SYS_FAULT	P05	VDD_INT	T06	VDD_EXT
K04	PC_09	M05	VDD_INT	P06	VDD_EXT	T07	GND

ADSP-SC582/SC583/SC584/SC587/SC589/ADSP-21583/21584/21587

Ball No.	Pin Name	Ball No.	Pin Name	Ball No.	Pin Name	Ball No.	Pin Name
T08	GND	V10	VDD_EXT	Y12	HADCO_VIN0	AB14	HADCO_VIN3
T09	GND	V11	VDD_EXT	Y13	HADCO_VIN7	AB15	RTC0_XTAL
T10	GND	V12	HADCO_VIN4	Y14	GND	AB16	MLB0_SIGN
T11	GND	V13	VDD_EXT	Y15	PB_05	AB17	MLB0_DATN
T12	GND	V14	VDD_EXT	Y16	PA_14	AB18	MLB0_CLKN
T13	GND	V15	VDD_EXT	Y17	PA_13	AB19	PA_15
T14	GND	V16	VDD_EXT	Y18	PA_12	AB20	PA_11
T15	GND	V17	VDD_EXT	Y19	PA_10	AB21	PA_06
T16	GND	V18	VDD_EXT	Y20	PA_00	AB22	PA_04
T17	GND	V19	VDD_INT	Y21	DAI1_PIN14	AB23	PA_02
T18	VDD_EXT	V20	DAI1_PIN16	Y22	DAI1_PIN17	AC01	GND
T19	VDD_INT	V21	DAI1_PIN06	Y23	DAI1_PIN15	AC02	PCIE0_RXP
T20	DAI1_PIN03	V22	DAI1_PIN12	AA01	PB_08	AC03	PCIE0_RXM
T21	PG_03	V23	DAI1_PIN09	AA02	PB_07	AC04	PCIE0_CLKM
T22	PG_02	W01	PB_12	AA03	DAIO_PIN16	AC05	PCIE0_CLKP
T23	DAI1_PIN01	W02	PB_09	AA04	DAIO_PIN07	AC06	PCIE0_TXP
U01	SYS_XTAL0	W03	DAIO_PIN18	AA05	DAIO_PIN06	AC07	PCIE0_TXM
U02	SYS_RESOUT	W04	DAIO_PIN11	AA06	DAIO_PIN01	AC08	USB1_DM
U03	PC_00	W05	VDD_INT	AA07	PCIE0_REF	AC09	USB1_DP
U04	DAIO_PIN20	W06	VDD_INT	AA08	USB1_VBUS	AC10	USB0_DP
U05	VDD_INT	W07	VDD_PCIE	AA09	USB0_VBUS	AC11	USB0_DM
U06	VDD_EXT	W08	VDD_INT	AA10	TWI1_SCL	AC12	HADCO_VREFP
U07	GND	W09	VDD_INT	AA11	TWI1_SDA	AC13	VDD_HADC
U08	GND	W10	VDD_INT	AA12	HADCO_VIN1	AC14	GND
U09	GND	W11	VDD_INT	AA13	HADCO_VIN5	AC15	RTC0_CLKIN
U10	GND	W12	HADCO_VIN6	AA14	PB_06	AC16	MLB0_SIGP
U11	GND	W13	VDD_INT	AA15	PB_02	AC17	MLB0_DATP
U12	GND	W14	VDD_RTC	AA16	PB_04	AC18	MLB0_CLKP
U13	GND	W15	VDD_INT	AA17	PB_03	AC19	PB_01
U14	GND	W16	VDD_INT	AA18	PB_00	AC20	PA_07
U15	GND	W17	VDD_INT	AA19	PA_09	AC21	PA_08
U16	GND	W18	VDD_INT	AA20	PA_05	AC22	PA_03
U17	GND	W19	VDD_INT	AA21	PA_01	AC23	GND
U18	VDD_EXT	W20	DAI1_PIN20	AA22	DAI1_PIN19		
U19	DAI1_PIN08	W21	DAI1_PIN11	AA23	DAI1_PIN18		
U20	DAI1_PIN07	W22	DAI1_PIN10	AB01	DAIO_PIN15		
U21	DAI1_PIN04	W23	DAI1_PIN13	AB02	DAIO_PIN14		
U22	DAI1_PIN05	Y01	PB_11	AB03	DAIO_PIN09		
U23	DAI1_PIN02	Y02	PB_10	AB04	DAIO_PIN13		
V01	SYS_CLKIN0	Y03	DAIO_PIN17	AB05	DAIO_PIN04		
V02	PB_13	Y04	DAIO_PIN08	AB06	DAIO_PIN02		
V03	DAIO_PIN19	Y05	DAIO_PIN05	AB07	DAIO_PIN03		
V04	DAIO_PIN12	Y06	DAIO_PIN10	AB08	USB_XTAL		
V05	VDD_INT	Y07	USB0_ID	AB09	USB_CLKIN		
V06	VDD_EXT	Y08	VDD_USB	AB10	TWI2_SCL		
V07	VDD_PCIE_RX	Y09	USB0_VBC	AB11	TWI0_SDA		
V08	VDD_PCIE_TX	Y10	TWI0_SCL	AB12	HADCO_VREFN		
V09	VDD_EXT	Y11	TWI2_SDA	AB13	HADCO_VIN2		

ADSP-SC582/SC583/SC584/SC587/SC589/ADSP-21583/21584/21587

ADSP-SC58x/ADSP-2158x 529-BALL BGA BALL ASSIGNMENTS (ALPHABETICAL BY PIN NAME)

Pin Name	Ball No.	Pin Name	Ball No.	Pin Name	Ball No.	Pin Name	Ball No.
DAIO_PIN01	AA06	DMC0_A06	F02	DMC1_A00	C08	DMC1_RZQ	E19
DAIO_PIN02	AB06	DMC0_A07	F05	DMC1_A01	C09	DMC1_UDM	C16
DAIO_PIN03	AB07	DMC0_A08	J03	DMC1_A02	D10	DMC1_UDQS	A20
DAIO_PIN04	AB05	DMC0_A09	G02	DMC1_A03	C07	DMC1_UDQS	A19
DAIO_PIN05	Y05	DMC0_A10	J02	DMC1_A04	C10	DMC1_VREF	A15
DAIO_PIN06	AA05	DMC0_A11	G04	DMC1_A05	D07	DMC1_WE	D08
DAIO_PIN07	AA04	DMC0_A12	H02	DMC1_A06	C11	GND	A01
DAIO_PIN08	Y04	DMC0_A13	G01	DMC1_A07	D09	GND	A23
DAIO_PIN09	AB03	DMC0_A14	H01	DMC1_A08	D12	GND	E06
DAIO_PIN10	Y06	DMC0_A15	J01	DMC1_A09	D17	GND	E07
DAIO_PIN11	W04	DMC0_BA0	D03	DMC1_A10	D19	GND	E08
DAIO_PIN12	V04	DMC0_BA1	E03	DMC1_A11	D20	GND	E09
DAIO_PIN13	AB04	DMC0_BA2	D04	DMC1_A12	C18	GND	F06
DAIO_PIN14	AB02	DMC0_CAS	F03	DMC1_A13	C19	GND	F09
DAIO_PIN15	AB01	DMC0_CK	A04	DMC1_A14	C17	GND	F16
DAIO_PIN16	AA03	DMC0_CKE	C04	DMC1_A15	D18	GND	J07
DAIO_PIN17	Y03	DMC0_CK	A03	DMC1_BA0	D11	GND	J08
DAIO_PIN18	W03	DMC0_CS0	C03	DMC1_BA1	C12	GND	J09
DAIO_PIN19	V03	DMC0_DQ00	B10	DMC1_BA2	D14	GND	J10
DAIO_PIN20	U04	DMC0_DQ01	A10	DMC1_CAS	D15	GND	J11
DAI1_PIN01	T23	DMC0_DQ02	B09	DMC1_CK	A16	GND	J12
DAI1_PIN02	U23	DMC0_DQ03	A09	DMC1_CKE	D13	GND	J13
DAI1_PIN03	T20	DMC0_DQ04	B08	DMC1_CK	A17	GND	J14
DAI1_PIN04	U21	DMC0_DQ05	A08	DMC1_CS0	C14	GND	J15
DAI1_PIN05	U22	DMC0_DQ06	B06	DMC1_DQ00	A12	GND	J16
DAI1_PIN06	V21	DMC0_DQ07	B07	DMC1_DQ01	B11	GND	J17
DAI1_PIN07	U20	DMC0_DQ08	B05	DMC1_DQ02	B12	GND	K07
DAI1_PIN08	U19	DMC0_DQ09	A05	DMC1_DQ03	A11	GND	K08
DAI1_PIN09	V23	DMC0_DQ10	B04	DMC1_DQ04	B13	GND	K09
DAI1_PIN10	W22	DMC0_DQ11	B03	DMC1_DQ05	B14	GND	K10
DAI1_PIN11	W21	DMC0_DQ12	B02	DMC1_DQ06	B15	GND	K11
DAI1_PIN12	V22	DMC0_DQ13	C02	DMC1_DQ07	B16	GND	K12
DAI1_PIN13	W23	DMC0_DQ14	C01	DMC1_DQ08	B17	GND	K13
DAI1_PIN14	Y21	DMC0_DQ15	D02	DMC1_DQ09	A18	GND	K14
DAI1_PIN15	Y23	DMC0_LDM	C05	DMC1_DQ10	B18	GND	K15
DAI1_PIN16	V20	DMC0_LDQS	A07	DMC1_DQ11	B19	GND	K16
DAI1_PIN17	Y22	DMC0_LDQS	A06	DMC1_DQ12	B20	GND	K17
DAI1_PIN18	AA23	DMC0_ODT	D05	DMC1_DQ13	A21	GND	L07
DAI1_PIN19	AA22	DMC0_RAS	E02	DMC1_DQ14	B21	GND	L08
DAI1_PIN20	W20	DMC0_RESET	K01	DMC1_DQ15	A22	GND	L09
DMC0_A00	H04	DMC0_RZQ	E05	DMC1_LDM	C15	GND	L10
DMC0_A01	F01	DMC0_UDM	D06	DMC1_LDQS	A13	GND	L11
DMC0_A02	F04	DMC0_UDQS	B01	DMC1_LDQS	A14	GND	L12
DMC0_A03	G03	DMC0_UDQS	A02	DMC1_ODT	C13	GND	L13
DMC0_A04	E01	DMC0_VREF	D01	DMC1_RAS	D16	GND	L14
DMC0_A05	H03	DMC0_WE	E04	DMC1_RESET	C06	GND	L15

ADSP-SC582/SC583/SC584/SC587/SC589/ADSP-21583/21584/21587

Pin Name	Ball No.	Pin Name	Ball No.	Pin Name	Ball No.	Pin Name	Ball No.
GND	L16	GND	T08	PA_02	AB23	PC_11	K02
GND	L17	GND	T09	PA_03	AC22	PC_12	L02
GND	M07	GND	T10	PA_04	AB22	PC_13	C20
GND	M08	GND	T11	PA_05	AA20	PC_14	D21
GND	M09	GND	T12	PA_06	AB21	PC_15	E20
GND	M10	GND	T13	PA_07	AC20	PD_00	B22
GND	M11	GND	T14	PA_08	AC21	PD_01	C21
GND	M12	GND	T15	PA_09	AA19	PD_02	F21
GND	M13	GND	T16	PA_10	Y19	PD_03	J19
GND	M14	GND	T17	PA_11	AB20	PD_04	B23
GND	M15	GND	U07	PA_12	Y18	PD_05	C23
GND	M16	GND	U08	PA_13	Y17	PD_06	C22
GND	M17	GND	U09	PA_14	Y16	PD_07	J20
GND	N07	GND	U10	PA_15	AB19	PD_08	E21
GND	N08	GND	U11	PB_00	AA18	PD_09	D23
GND	N09	GND	U12	PB_01	AC19	PD_10	D22
GND	N10	GND	U13	PB_02	AA15	PD_11	E23
GND	N11	GND	U14	PB_03	AA17	PD_12	F23
GND	N12	GND	U15	PB_04	AA16	PD_13	F22
GND	N13	GND	U16	PB_05	Y15	PD_14	E22
GND	N14	GND	U17	PB_06	AA14	PD_15	K20
GND	N15	GND	Y14	PB_07	AA02	PE_00	G23
GND	N16	GND	AC01	PB_08	AA01	PE_01	G22
GND	N17	GND	AC14	PB_09	W02	PE_02	H23
GND	P07	GND	AC23	PB_10	Y02	PE_03	L20
GND	P08	HADC0_VIN0	Y12	PB_11	Y01	PE_04	G20
GND	P09	HADC0_VIN1	AA12	PB_12	W01	PE_05	H22
GND	P10	HADC0_VIN2	AB13	PB_13	V02	PE_06	F20
GND	P11	HADC0_VIN3	AB14	PB_14	T04	PE_07	J23
GND	P12	HADC0_VIN4	V12	PB_15	T02	PE_08	M19
GND	P13	HADC0_VIN5	AA13	PCIE0_CLKM	AC04	PE_09	L22
GND	P14	HADC0_VIN6	W12	PCIE0_CLKP	AC05	PE_10	K23
GND	P15	HADC0_VIN7	Y13	PCIE0_REF	AA07	PE_11	M20
GND	P16	HADC0_VREFN	AB12	PCIE0_RXM	AC03	PE_12	H21
GND	P17	HADC0_VREFP	AC12	PCIE0_RXP	AC02	PE_13	G21
GND	R07	JTG_TCK	P04	PCIE0_TXM	AC07	PE_14	L23
GND	R08	JTG_TDI	P02	PCIE0_TXP	AC06	PE_15	N20
GND	R09	JTG_TDO	P01	PC_00	U03	PF_00	M22
GND	R10	JTG_TMS	N01	PC_01	M01	PF_01	J22
GND	R11	JTG_TRST	N02	PC_02	M03	PF_02	M23
GND	R12	MLB0_CLKN	AB18	PC_03	N04	PF_03	M21
GND	R13	MLB0_CLKP	AC18	PC_04	L01	PF_04	N21
GND	R14	MLB0_DATN	AB17	PC_05	M02	PF_05	N22
GND	R15	MLB0_DATP	AC17	PC_06	K03	PF_06	K22
GND	R16	MLB0_SIGN	AB16	PC_07	L03	PF_07	N23
GND	R17	MLB0_SIGP	AC16	PC_08	J04	PF_08	P20
GND	T03	PA_00	Y20	PC_09	K04	PF_09	L21
GND	T07	PA_01	AA21	PC_10	L04	PF_10	P19

ADSP-SC582/SC583/SC584/SC587/SC589/ADSP-21583/21584/21587

Pin Name	Ball No.	Pin Name	Ball No.	Pin Name	Ball No.	Pin Name	Ball No.
PF_11	K21	VDD_DMC	G13	VDD_INT	E10	VDD_INT	W16
PF_12	P22	VDD_DMC	G14	VDD_INT	E11	VDD_INT	W17
PF_13	R23	VDD_DMC	G15	VDD_INT	E12	VDD_INT	W18
PF_14	J21	VDD_DMC	G16	VDD_INT	E13	VDD_INT	W19
PF_15	P21	VDD_DMC	G17	VDD_INT	E14	VDD_PCIE	W07
PG_00	P23	VDD_DMC	G18	VDD_INT	E15	VDD_PCIE_RX	V07
PG_01	R20	VDD_DMC	H06	VDD_INT	E16	VDD_PCIE_TX	V08
PG_02	T22	VDD_DMC	H07	VDD_INT	E17	VDD_RTC	W14
PG_03	T21	VDD_DMC	H08	VDD_INT	E18	VDD_USB	Y08
PG_04	R22	VDD_DMC	H09	VDD_INT	F07		
PG_05	R21	VDD_DMC	H10	VDD_INT	F08		
RTC0_CLKIN	AC15	VDD_DMC	H11	VDD_INT	F10		
RTC0_XTAL	AB15	VDD_DMC	H12	VDD_INT	F11		
SYS_BMODE0	R04	VDD_DMC	H13	VDD_INT	F12		
SYS_BMODE1	R02	VDD_DMC	H14	VDD_INT	F13		
SYS_BMODE2	R03	VDD_DMC	H15	VDD_INT	F14		
SYS_CLKIN0	V01	VDD_DMC	H16	VDD_INT	F15		
SYS_CLKIN1	T01	VDD_DMC	H17	VDD_INT	F17		
SYS_CLKOUT	H20	VDD_DMC	H18	VDD_INT	F18		
SYS_FAULT	P03	VDD_DMC	J06	VDD_INT	F19		
<u>SYS_FAULT</u>	M04	VDD_DMC	K06	VDD_INT	G05		
<u>SYS_HWRST</u>	N03	VDD_DMC	L06	VDD_INT	G19		
<u>SYS_RESOUT</u>	U02	VDD_DMC	M06	VDD_INT	H05		
SYS_XTAL0	U01	VDD_EXT	J18	VDD_INT	H19		
SYS_XTAL1	R01	VDD_EXT	K18	VDD_INT	J05		
TWI0_SCL	Y10	VDD_EXT	L18	VDD_INT	K05		
TWI0_SDA	AB11	VDD_EXT	M18	VDD_INT	K19		
TWI1_SCL	AA10	VDD_EXT	N06	VDD_INT	L05		
TWI1_SDA	AA11	VDD_EXT	N18	VDD_INT	L19		
TWI2_SCL	AB10	VDD_EXT	P06	VDD_INT	M05		
TWI2_SDA	Y11	VDD_EXT	P18	VDD_INT	N05		
USB0_DM	AC11	VDD_EXT	R06	VDD_INT	N19		
USB0_DP	AC10	VDD_EXT	R18	VDD_INT	P05		
USB0_ID	Y07	VDD_EXT	T06	VDD_INT	R05		
USB0_VBC	Y09	VDD_EXT	T18	VDD_INT	R19		
USB0_VBUS	AA09	VDD_EXT	U06	VDD_INT	T05		
USB1_DM	AC08	VDD_EXT	U18	VDD_INT	T19		
USB1_DP	AC09	VDD_EXT	V06	VDD_INT	U05		
USB1_VBUS	AA08	VDD_EXT	V09	VDD_INT	V05		
USB_CLKIN	AB09	VDD_EXT	V10	VDD_INT	V19		
USB_XTAL	AB08	VDD_EXT	V11	VDD_INT	W05		
VDD_DMC	G06	VDD_EXT	V13	VDD_INT	W06		
VDD_DMC	G07	VDD_EXT	V14	VDD_INT	W08		
VDD_DMC	G08	VDD_EXT	V15	VDD_INT	W09		
VDD_DMC	G09	VDD_EXT	V16	VDD_INT	W10		
VDD_DMC	G10	VDD_EXT	V17	VDD_INT	W11		
VDD_DMC	G11	VDD_EXT	V18	VDD_INT	W13		
VDD_DMC	G12	VDD_HADC	AC13	VDD_INT	W15		

ADSP-SC582/SC583/SC584/SC587/SC589/ADSP-21583/21584/21587

CONFIGURATION OF THE 529-BALL CSP_BGA

Figure 103 shows an overview of signal placement on the 529-ball CSP_BGA.

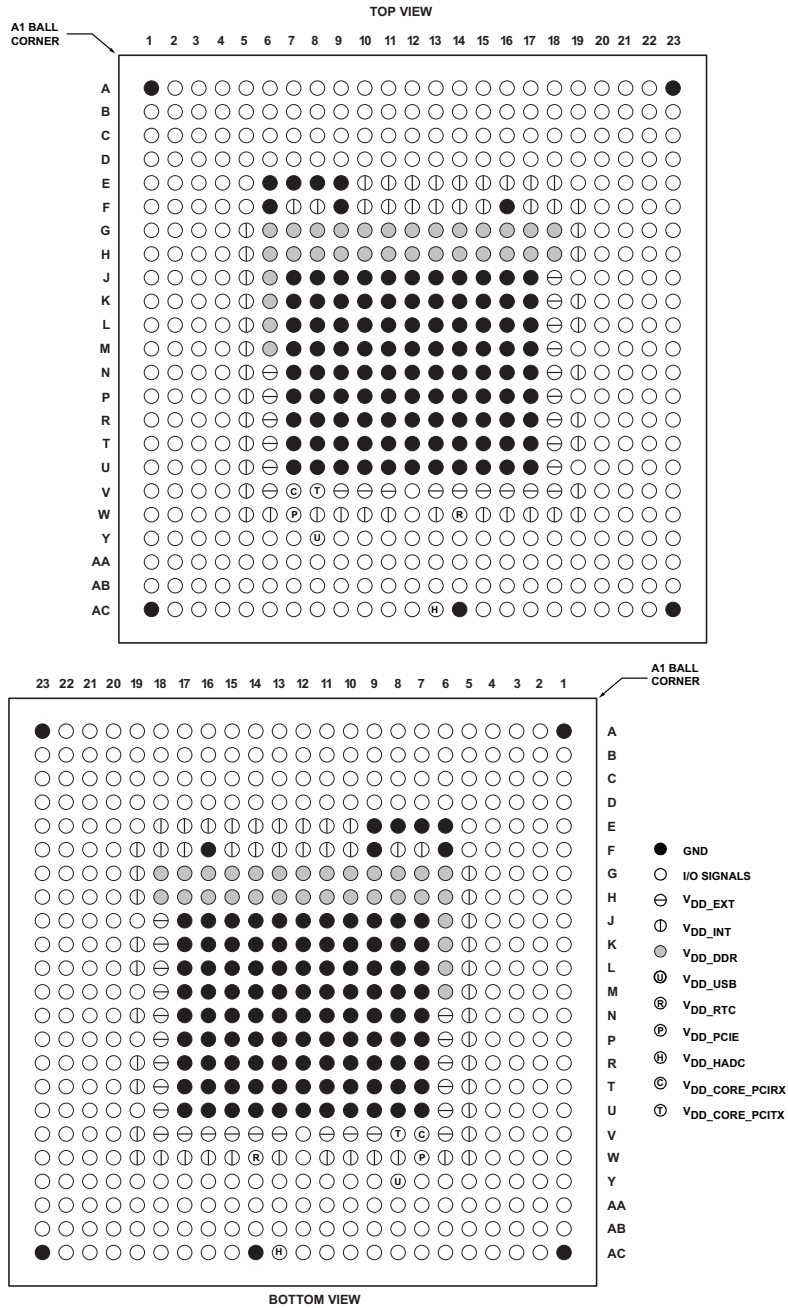
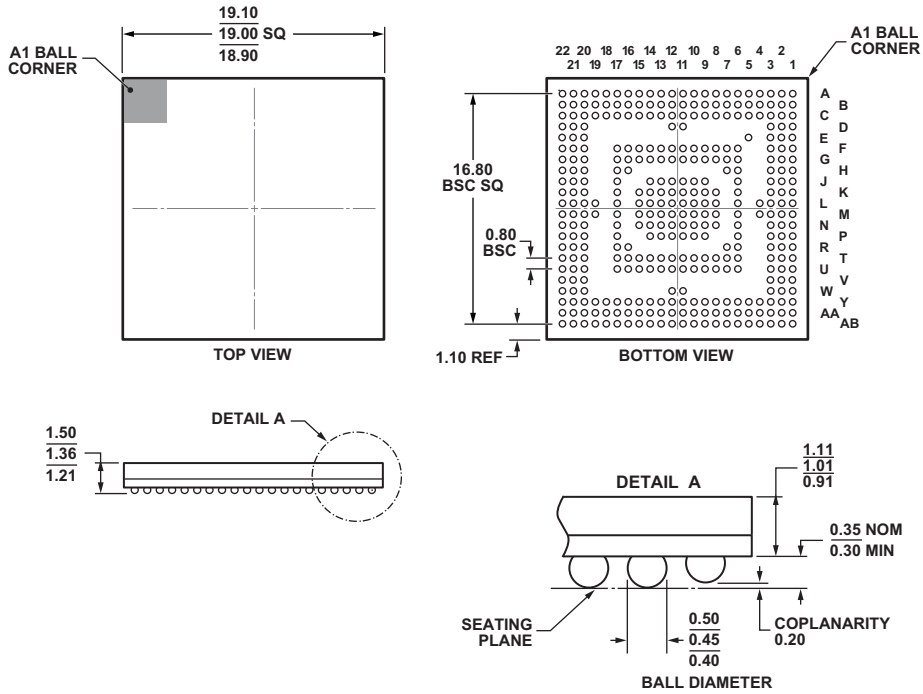

Figure 103. 529-Ball CSP_BGA Configuration

ADSP-SC582/SC583/SC584/SC587/SC589/ADSP-21583/21584/21587

OUTLINE DIMENSIONS

Dimensions for the 19 mm × 19 mm 349-ball CSP_BGA package in Figure 104 are shown in millimeters.



COMPLIANT TO JEDEC STANDARDS MO-275-PPAB-2.

Figure 104. 349-Ball Chip Scale Package Ball Grid Array [CSP_BGA] (BC-349-1)

Dimensions shown in millimeters

ADSP-SC582/SC583/SC584/SC587/SC589/ADSP-21583/21584/21587

Dimensions for the 19 mm × 19 mm 529-ball CSP_BGA package in [Figure 105](#) are shown in millimeters.

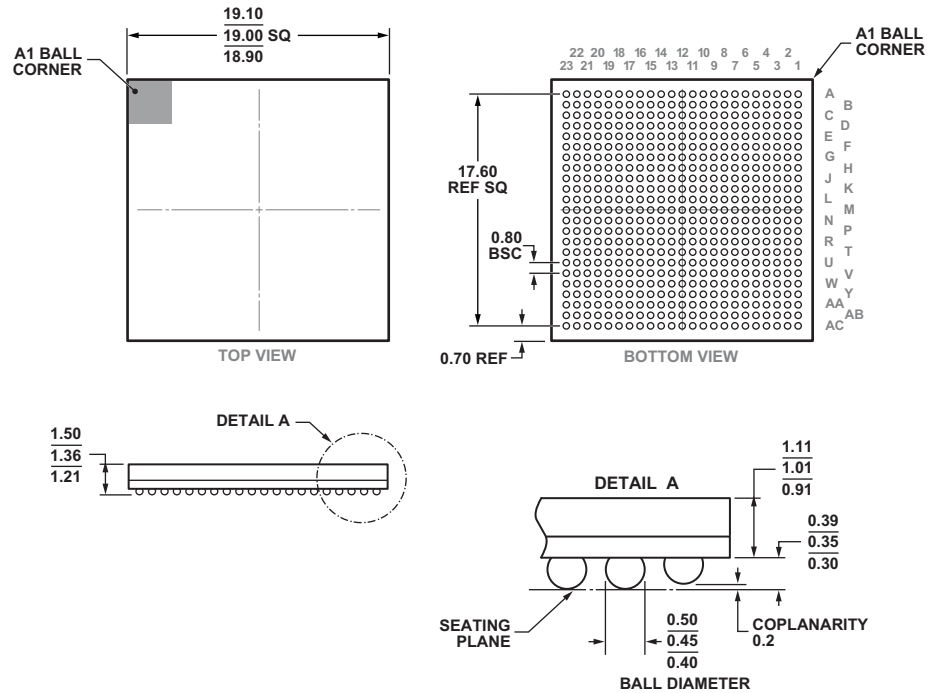

COMPLIANT TO JEDEC STANDARDS MO-275-RRAB-2.

*Figure 105. 529-Ball Chip Scale Package Ball Grid Array [CSP_BGA]
(BC-529-1)
Dimensions shown in millimeters*

SURFACE-MOUNT DESIGN

[Table 109](#) is an aid for PCB design. For industry-standard design recommendations, refer to IPC-7351, *Generic Requirements for Surface-Mount Design and Land Pattern Standard*.

Table 109. CSP_BGA Data for Use with Surface-Mount Design

Package	Package Ball Attach Type	Package Solder Mask Opening	Package Ball Pad Size
BC-349-1	Solder Mask Defined	0.4 mm Diameter	0.5 mm Diameter
BC-529-1	Solder Mask Defined	0.4 mm Diameter	0.5 mm Diameter

ADSP-SC582/SC583/SC584/SC587/SC589/ADSP-21583/21584/21587

AUTOMOTIVE PRODUCTS

The following models are available with controlled manufacturing to support the quality and reliability requirements of automotive applications. Note that these automotive models may have specifications that differ from the nonautomotive models; therefore designers should review the [Specifications](#) section of this data sheet carefully. Only the automotive grade

products shown in [Table 110](#) are available for use in automotive applications. Contact your local Analog Devices account representative for specific product ordering information and to obtain the specific Automotive Reliability reports for these models.

Table 110. Automotive Products

Model ^{1,2}	Processor Instruction Rate (Max)	Temperature Range ³	Arm Cores ⁴	SHARC+ Cores	SHARC+ SRAM	PCIe Lanes ⁴	Package Description	Package Option
AD21583WCBCZ4Axx	450 MHz	-40°C to +105°C	N/A	2	384 kB	N/A	349-Ball cspBGA	BC-349-1
AD21584WCBCZ4Axx	450 MHz	-40°C to +105°C	N/A	2	640 kB	N/A	349-Ball cspBGA	BC-349-1
AD21584WCBCZ5Axx	500 MHz	-40°C to +100°C	N/A	2	640 kB	N/A	349-Ball cspBGA	BC-349-1
ADSC582WCBCZ4Axx	450 MHz	-40°C to +105°C	1	1	640 kB	N/A	349-Ball cspBGA	BC-349-1
ADSC583WCBCZ3Axx	300 MHz	-40°C to +105°C	1	2	384 kB	N/A	349-Ball cspBGA	BC-349-1
ADSC583WCBCZ4Axx	450 MHz	-40°C to +105°C	1	2	384 kB	N/A	349-Ball cspBGA	BC-349-1
ADSC584WCBCZ3Axx	300 MHz	-40°C to +105°C	1	2	640 kB	N/A	349-Ball cspBGA	BC-349-1
ADSC584WCBCZ4Axx	450 MHz	-40°C to +105°C	1	2	640 kB	N/A	349-Ball cspBGA	BC-349-1
ADSC584WCBCZ5Axx	500 MHz	-40°C to +100°C	1	2	640 kB	N/A	349-Ball cspBGA	BC-349-1
ADSC587WCBCZ4Bxx	450 MHz	-40°C to +105°C	1	2	640 kB	N/A	529-Ball cspBGA	BC-529-1
ADSC587WBBCZ5Bxx	500 MHz	-40°C to +85°C	1	2	640 kB	N/A	529-Ball cspBGA	BC-529-1

¹ Z = RoHS Compliant Part.

² xx denotes the current die revision.

³ Referenced temperature is ambient temperature. The ambient temperature is not a specification. Please see the [Operating Conditions](#) section for the junction temperature (T_j) specification which is the only temperature specification.

⁴ N/A means not applicable.

ADSP-SC582/SC583/SC584/SC587/SC589/ADSP-21583/21584/21587

ORDERING GUIDE

Model ¹	Processor Instruction Rate (Max)	Temperature Range ²	Arm Cores ³	SHARC+ Cores	SHARC+ SRAM	PCIe Lanes ³	Package Description	Package Option
ADSP-21583KBCZ-4A	450 MHz	0°C to +70°C	N/A	2	384 kB	N/A	349-Ball cspBGA	BC-349-1
ADSP-21583BBCZ-4A	450 MHz	-40°C to +85°C	N/A	2	384 kB	N/A	349-Ball cspBGA	BC-349-1
ADSP-21583CBCZ-4A	450 MHz	-40°C to +95°C	N/A	2	384 kB	N/A	349-Ball cspBGA	BC-349-1
ADSP-21584KBCZ-4A	450 MHz	0°C to +70°C	N/A	2	640 kB	N/A	349-Ball cspBGA	BC-349-1
ADSP-21584KBCZ-5A	500 MHz	0°C to +70°C	N/A	2	640 kB	N/A	349-Ball cspBGA	BC-349-1
ADSP-21584BBCZ-4A	450 MHz	-40°C to +85°C	N/A	2	640 kB	N/A	349-Ball cspBGA	BC-349-1
ADSP-21584BBCZ-5A	500 MHz	-40°C to +85°C	N/A	2	640 kB	N/A	349-Ball cspBGA	BC-349-1
ADSP-21584CBCZ-4A	450 MHz	-40°C to +95°C	N/A	2	640 kB	N/A	349-Ball cspBGA	BC-349-1
ADSP-21584CBCZ-5A	500 MHz	-40°C to +90°C	N/A	2	640 kB	N/A	349-Ball cspBGA	BC-349-1
ADSP-21587KBCZ-4B	450 MHz	0°C to +70°C	N/A	2	640 kB	N/A	529-Ball cspBGA	BC-529-1
ADSP-21587KBCZ-5B	500 MHz	0°C to +70°C	N/A	2	640 kB	N/A	529-Ball cspBGA	BC-529-1
ADSP-21587BBCZ-4B	450 MHz	-40°C to +85°C	N/A	2	640 kB	N/A	529-Ball cspBGA	BC-529-1
ADSP-21587BBCZ-5B	500 MHz	-40°C to +80°C	N/A	2	640 kB	N/A	529-Ball cspBGA	BC-529-1
ADSP-SC582KBCZ-4A	450 MHz	0°C to +70°C	1	1	640 kB	N/A	349-Ball cspBGA	BC-349-1
ADSP-SC582BBCZ-4A	450 MHz	-40°C to +85°C	1	1	640 kB	N/A	349-Ball cspBGA	BC-349-1
ADSP-SC582CBCZ-4A	450 MHz	-40°C to +95°C	1	1	640 kB	N/A	349-Ball cspBGA	BC-349-1
ADSP-SC583KBCZ-3A	300 MHz	0°C to +70°C	1	2	384 kB	N/A	349-Ball cspBGA	BC-349-1
ADSP-SC583BBCZ-3A	300 MHz	-40°C to +85°C	1	2	384 kB	N/A	349-Ball cspBGA	BC-349-1
ADSP-SC583CBCZ-3A	300 MHz	-40°C to +95°C	1	2	384 kB	N/A	349-Ball cspBGA	BC-349-1
ADSP-SC583KBCZ-4A	450 MHz	0°C to +70°C	1	2	384 kB	N/A	349-Ball cspBGA	BC-349-1
ADSP-SC583BBCZ-4A	450 MHz	-40°C to +85°C	1	2	384 kB	N/A	349-Ball cspBGA	BC-349-1
ADSP-SC583CBCZ-4A	450 MHz	-40°C to +95°C	1	2	384 kB	N/A	349-Ball cspBGA	BC-349-1
ADSP-SC584KBCZ-3A	300 MHz	0°C to +70°C	1	2	640 kB	N/A	349-Ball cspBGA	BC-349-1
ADSP-SC584BBCZ-3A	300 MHz	-40°C to +85°C	1	2	640 kB	N/A	349-Ball cspBGA	BC-349-1
ADSP-SC584CBCZ-3A	300 MHz	-40°C to +95°C	1	2	640 kB	N/A	349-Ball cspBGA	BC-349-1
ADSP-SC584KBCZ-4A	450 MHz	0°C to +70°C	1	2	640 kB	N/A	349-Ball cspBGA	BC-349-1
ADSP-SC584KBCZ-5A	500 MHz	0°C to +70°C	1	2	640 kB	N/A	349-Ball cspBGA	BC-349-1
ADSP-SC584BBCZ-4A	450 MHz	-40°C to +85°C	1	2	640 kB	N/A	349-Ball cspBGA	BC-349-1
ADSP-SC584BBCZ-5A	500 MHz	-40°C to +85°C	1	2	640 kB	N/A	349-Ball cspBGA	BC-349-1
ADSP-SC584CBCZ-4A	450 MHz	-40°C to +95°C	1	2	640 kB	N/A	349-Ball cspBGA	BC-349-1
ADSP-SC584CBCZ-5A	500 MHz	-40°C to +90°C	1	2	640 kB	N/A	349-Ball cspBGA	BC-349-1
ADSP-SC587KBCZ-4B	450 MHz	0°C to +70°C	1	2	640 kB	N/A	529-Ball cspBGA	BC-529-1
ADSP-SC587KBCZ-5B	500 MHz	0°C to +70°C	1	2	640 kB	N/A	529-Ball cspBGA	BC-529-1
ADSP-SC587BBCZ-4B	450 MHz	-40°C to +85°C	1	2	640 kB	N/A	529-Ball cspBGA	BC-529-1
ADSP-SC587BBCZ-5B	500 MHz	-40°C to +80°C	1	2	640 kB	N/A	529-Ball cspBGA	BC-529-1
ADSP-SC589KBCZ-4B	450 MHz	0°C to +70°C	1	2	640 kB	1	529-Ball cspBGA	BC-529-1
ADSP-SC589KBCZ-5B	500 MHz	0°C to +70°C	1	2	640 kB	1	529-Ball cspBGA	BC-529-1
ADSP-SC589BBCZ-4B	450 MHz	-40°C to +85°C	1	2	640 kB	1	529-Ball cspBGA	BC-529-1
ADSP-SC589BBCZ-5B	500 MHz	-40°C to +80°C	1	2	640 kB	1	529-Ball cspBGA	BC-529-1

¹Z =RoHS Compliant Part.

²Referenced temperature is ambient temperature. The ambient temperature is not a specification. Please see the [Operating Conditions](#) section for the junction temperature (T_j) specification which is the only temperature specification.

³N/A means not applicable.

I²C refers to a communications protocol originally developed by Philips Semiconductors (now NXP Semiconductors).

©2018 Analog Devices, Inc. All rights reserved. Trademarks and registered trademarks are the property of their respective owners.
D13317-0-12/18(B)



www.analog.com

Mouser Electronics

Authorized Distributor

Click to View Pricing, Inventory, Delivery & Lifecycle Information:

[Analog Devices Inc.:](#)

[ADSP-21587BBCZ-4B](#) [ADSP-21587KBCZ-4B](#) [ADSP-21587BBCZ-5B](#) [ADSP-21587KBCZ-5B](#)