

THIS DRAWING IS UNPUBLISHED. RELEASED FOR PUBLICATION
 © COPYRIGHT - BY - ALL RIGHTS RESERVED.

LOC	DIST	REVISIONS					
		P	LTR	DESCRIPTION	DATE	DWN	APVD
-	-	B		ECR-16-006831 PACKAGE TRAY CHANGE	04MAY2016	L.Z.	X.X.
		C		ECR-18-010755	11NOV2018	GCM	PP
		C1		ADDED NEW PART VARIANT 3--1 AND 3--2	19OCT2020	SS	JDB
		C2		ADDED NEW PART VARIANT 4--1	19MAY2021	SS	JDB

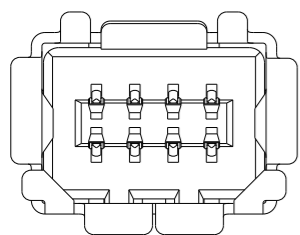

2271656-2
TYPE II

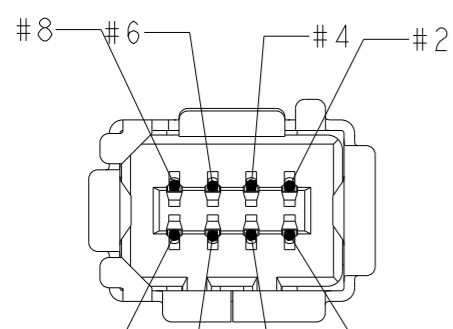
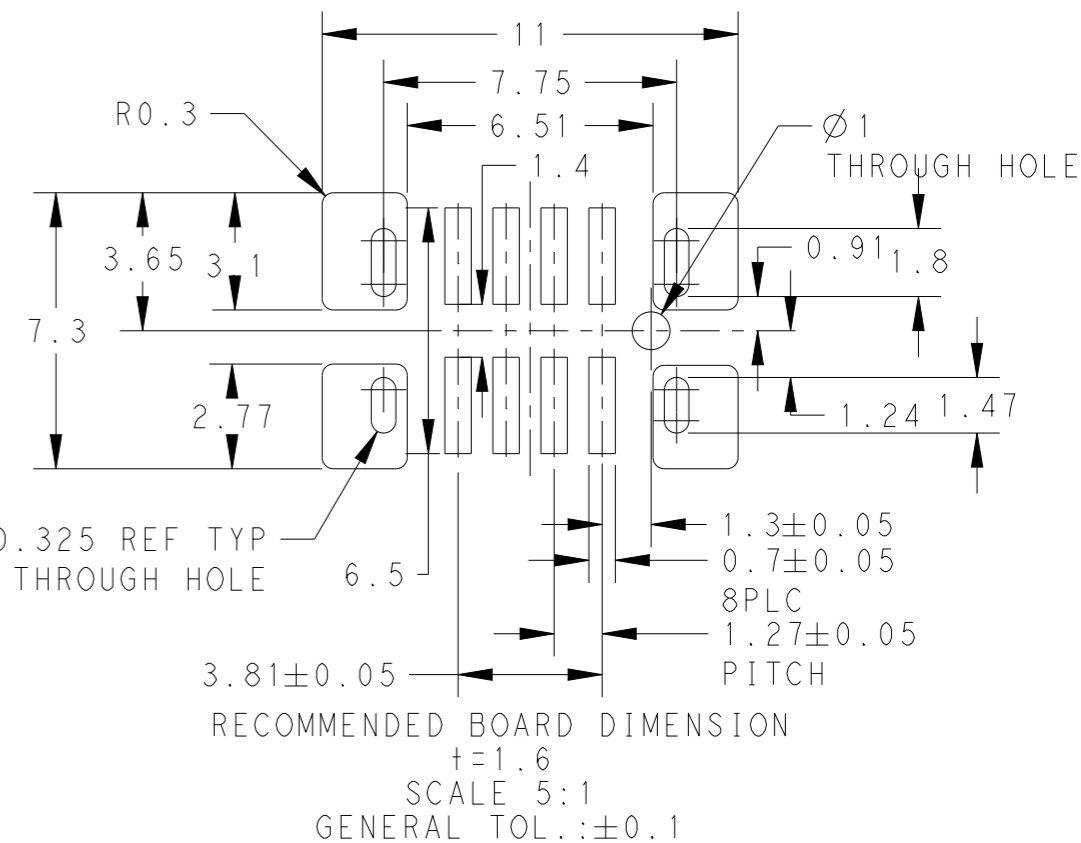
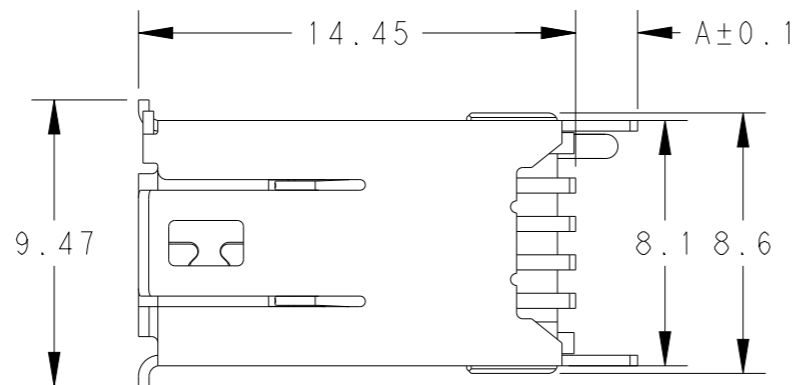

2271656-1
TYPE I

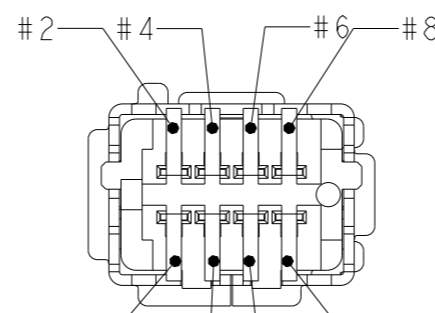
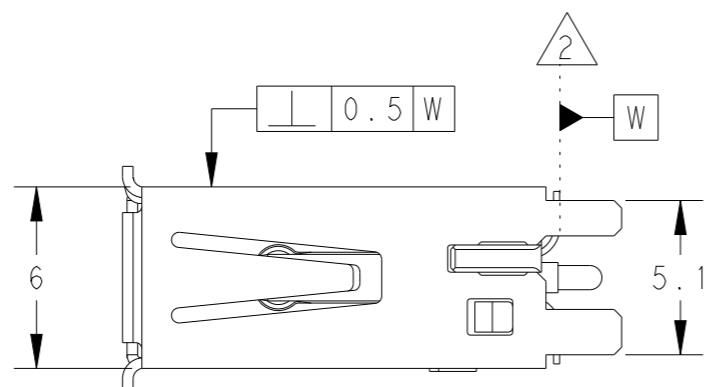

CIRCUIT NO

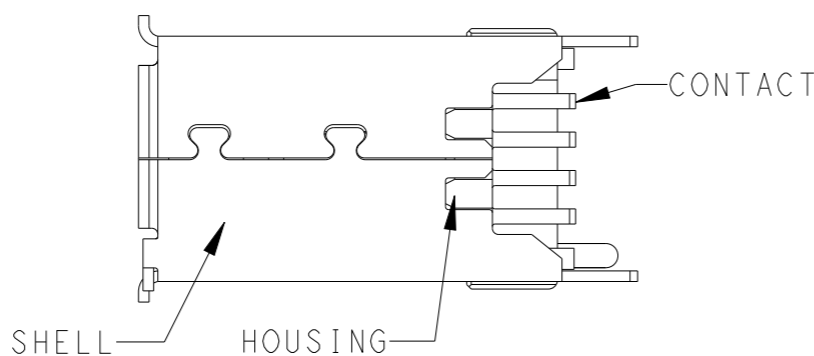

DIM	POS	TOP CONTACT AREA	DESCRIPTION	PART NO	
1.5	8	GOLD 0.5µm MIN	TYPE I SMT RECEPTACLE	4-2271656-1	
PRELIMINARY	2.05	8	GOLD 0.76µm MIN	TYPE II SMT RECEPTACLE WITH EMBOSS TAPE	3-2271656-2
PRELIMINARY	2.05	8	GOLD 0.76µm MIN	TYPE I SMT RECEPTACLE WITH EMBOSS TAPE	3-2271656-1
	2.05	8	GOLD 0.5µm MIN	TYPE II SMT RECEPTACLE WITH CAP ON EMBOSS TAPE	2-2271656-2
	2.05	8	GOLD 0.5µm MIN	TYPE I SMT RECEPTACLE WITH CAP ON EMBOSS TAPE	2-2271656-1
	2.05	8	GOLD 0.5µm MIN	TYPE II SMT RECEPTACLE WITH CAP	1-2271656-2
	2.05	8	GOLD 0.5µm MIN	TYPE I SMT RECEPTACLE WITH CAP	1-2271656-1
	2.05	8	GOLD 0.5µm MIN	TYPE II SMT RECEPTACLE	2271656-2
	2.05	8	GOLD 0.5µm MIN	TYPE I SMT RECEPTACLE	2271656-1

NOTES:
 1 MATERIAL AND FINISH
 CONTACT: COPPER ALLOY
 UNDER ALL SURFACE NICKEL 1.27µm MIN.
 TOP CONTACT AREA: SEE TABLE
 SOLDERING AREA: TIN PLATE
 HOUSING: THERMO PLASTIC (UL94V-0)
 SHELL: COPPER ALLOY
 UNDER ALL SURFACE NICKEL
 TOP ALL SURFACE TIN
 2 COPLANARITY 0.1 MAX (IN 8 TIPS OF CONTACTS)
 DATUM -W- IS THE SEATING PLANE FOR ALL 8 CONTACT LEGS
 3 GENERAL TOL.: ±0.3; ±5°

THIS DRAWING IS A CONTROLLED DOCUMENT.

DWN: LEAR ZHANG 01DEC2015
 CHK: KOBBY ZHAO 01DEC2015
 APVD: XU XIANG 01DEC2015

NAME: SMT VERTICAL MINI I/O RECEPTACLE 1.27mm PITCH

TE Connectivity

STE

108-106087

SIZE: A3 CAGE CODE: - DRAWING NO: C-2271656 RESTRICTED TO: -

SCALE: 4:1 SHEET: 1 OF 4 REV: C2

CUSTOMER DRAWING

4

3

2

1

THIS DRAWING IS UNPUBLISHED. RELEASED FOR PUBLICATION
 © COPYRIGHT - BY - ALL RIGHTS RESERVED.

LOC	DIST	REVISIONS					
-	-	P	LTR	DESCRIPTION	DATE	DWN	APVD
				SEE SHEET 1	-	-	-

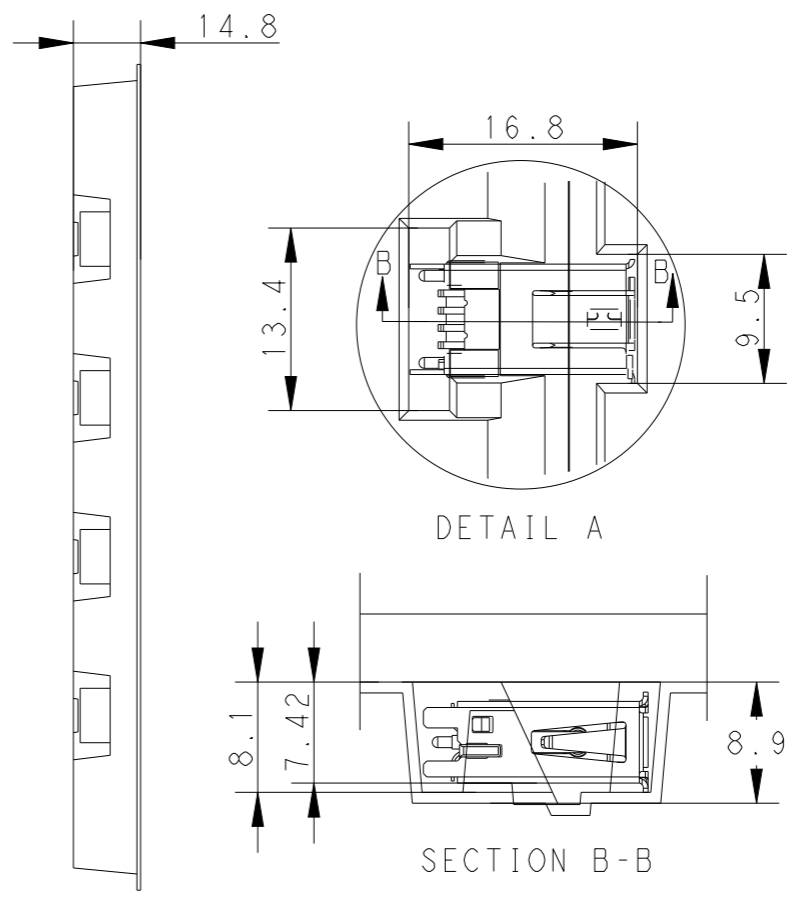
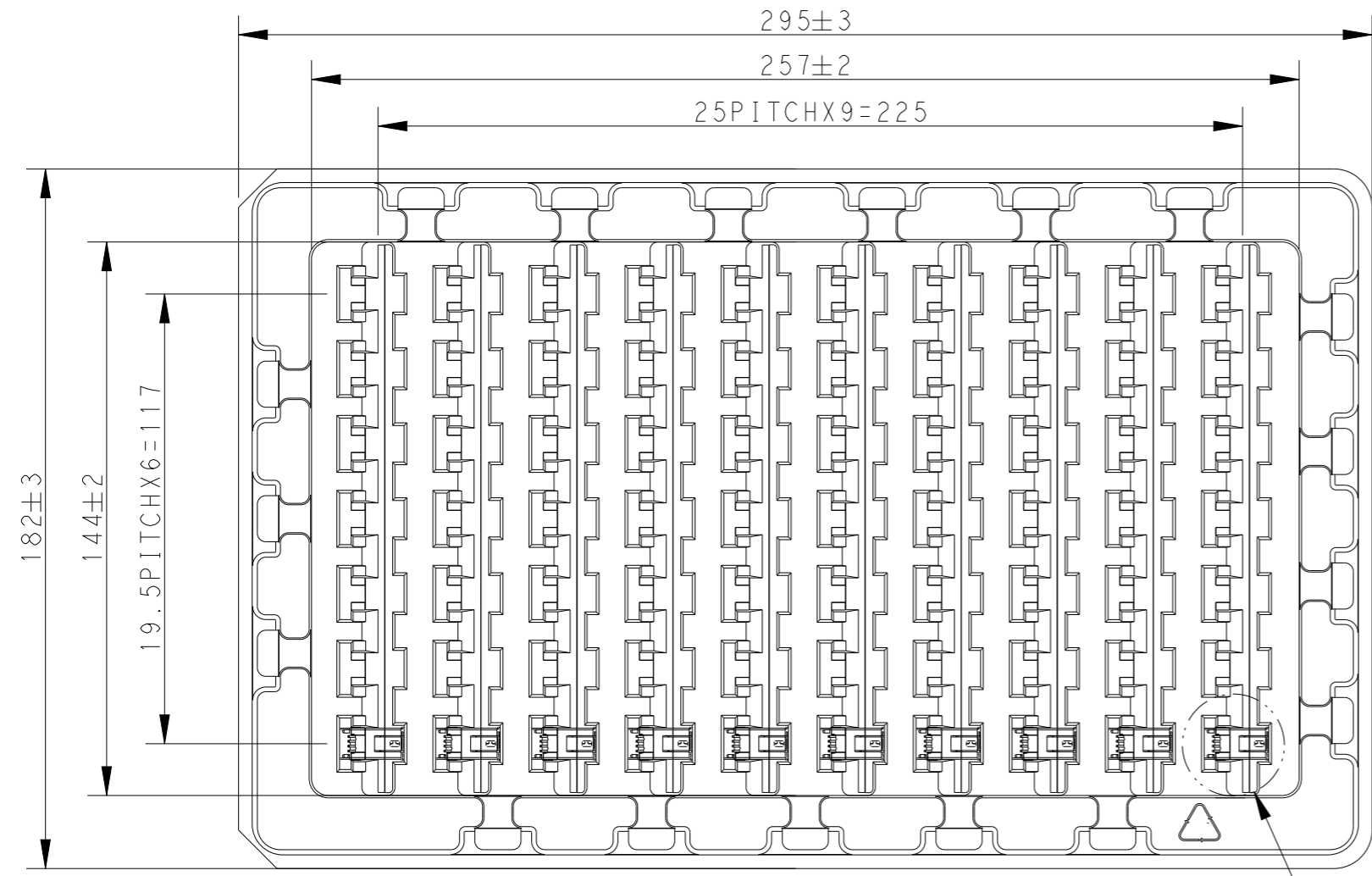

SEE DETAIL A

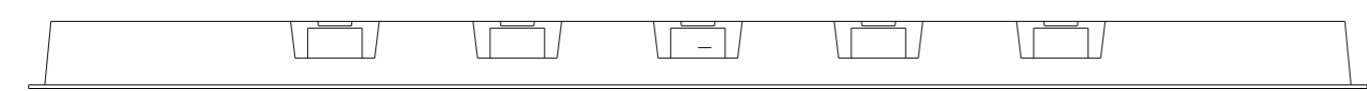

NOTE:
 4 PACKAGE:
 70PCS PER TRAY FOR 2271656-1, 2271656-2
 AND 4-2271656-1

PACKAGE AS SHOWN	4-2271656-1
	2271656-2
	2271656-1
DESCRIPTION	PART NO

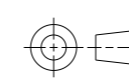
THIS DRAWING IS A CONTROLLED DOCUMENT.		DWN	01DEC2015	 TE Connectivity	NAME SMT VERTICAL MINI I/O RECEPTACLE 1.27mm PITCH
DIMENSIONS: mm		CHK	01DEC2015		
		APVD	01DEC2015		
TOLERANCES UNLESS OTHERWISE SPECIFIED:		PRODUCT SPEC	108-106087		
0 PLC ±- 1 PLC ±- 2 PLC ±- 3 PLC ±- 4 PLC ±- ANGLES ±- MATERIAL - FINISH -		APPLICATION SPEC	-	SIZE	A3
		WEIGHT	-	CAGE CODE	-
		CUSTOMER DRAWING		DRAWING NO	©-2271656
				RESTRICTED TO	-
				SCALE	4:1
				SHEET	2 OF 4
				REV	C2

4

3

2

1

THIS DRAWING IS UNPUBLISHED. RELEASED FOR PUBLICATION
 © COPYRIGHT - BY - ALL RIGHTS RESERVED.

LOC	DIST	REVISIONS			
P	LTR	DESCRIPTION	DATE	DWN	APVD
-	-	SEE SHEET 1	-	-	-

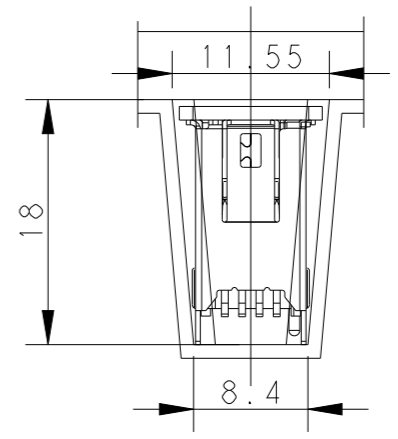
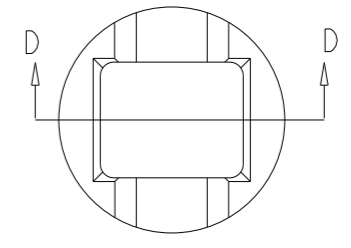
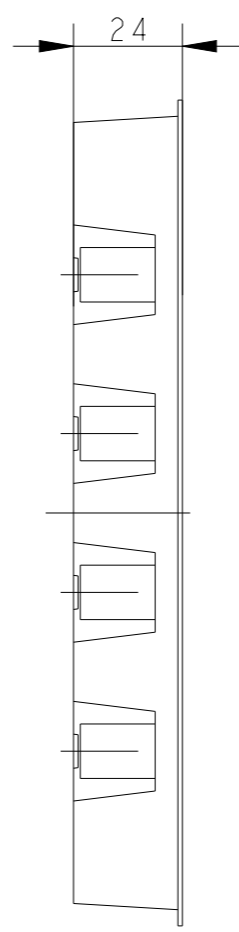
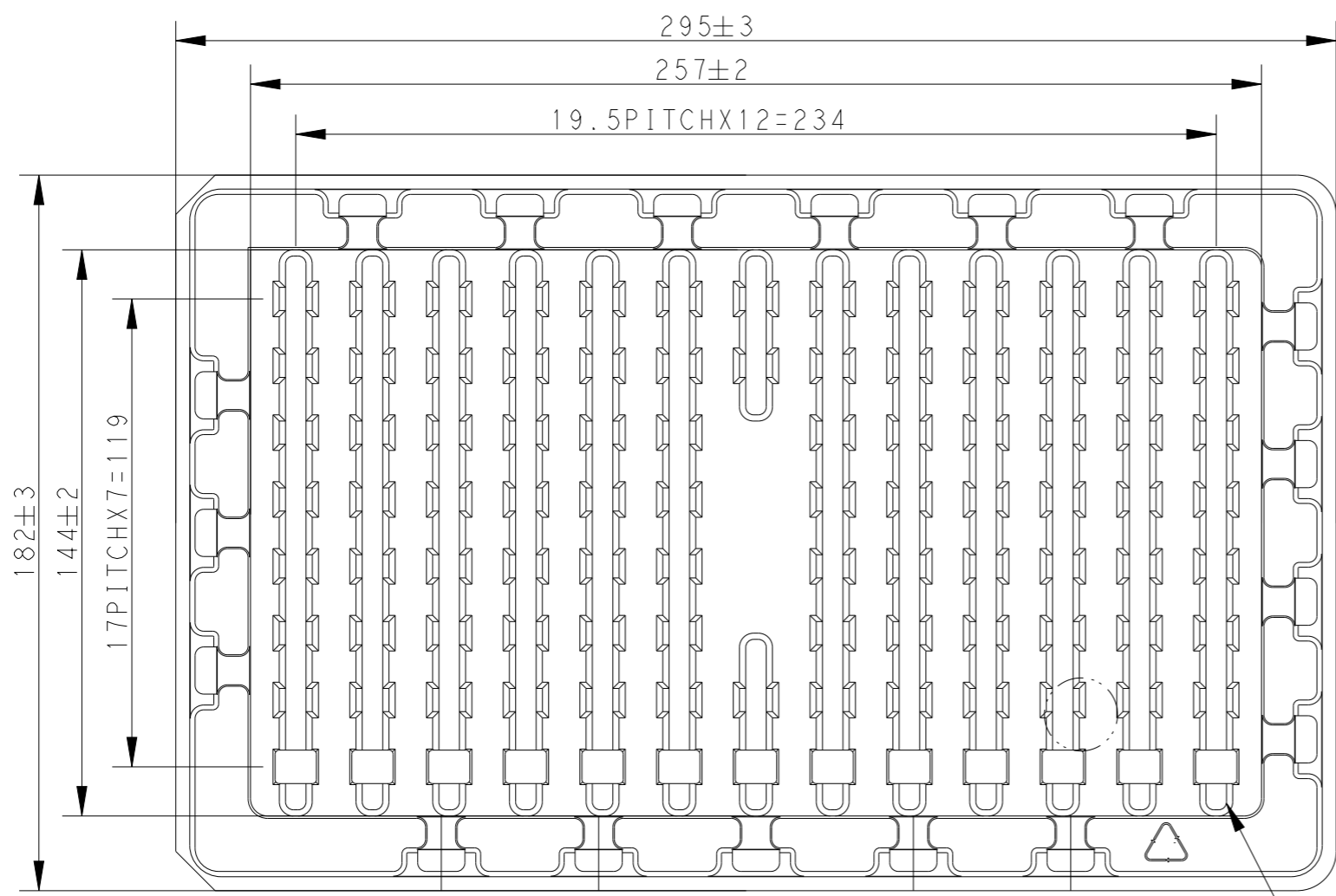

SEE DETAIL C

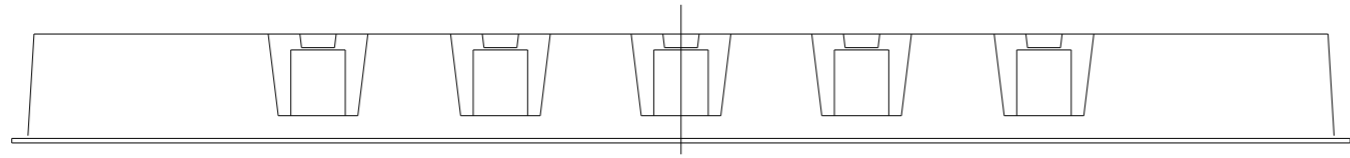

NOTE:
 5 PACKAGE:
 100PCS PER TRAY FOR 1-2271656-1 & 1-2271656-2

THIS DRAWING IS A CONTROLLED DOCUMENT.

DIMENSIONS:	TOLERANCES UNLESS OTHERWISE SPECIFIED:
mm	0 PLC ±-
	1 PLC ±-
	2 PLC ±-
	3 PLC ±-
	4 PLC ±-
	ANGLES ±-
MATERIAL	FINISH

DWN	01DEC2015
LEAR ZHANG	
CHK	01DEC2015
KOBBY ZHAO	
APVD	01DEC2015
XU XIANG	
PRODUCT SPEC	108-106087
APPLICATION SPEC	-
WEIGHT	-

PACKAGE AS SHOWN	1-2271656-2
	1-2271656-1
DESCRIPTION	PART NO



NAME			
SMT VERTICAL MINI I/O RECEPTACLE			
1.27mm PITCH			
SIZE	CAGE CODE	DRAWING NO	RESTRICTED TO
A3	-	©-2271656	-
CUSTOMER DRAWING		SCALE	SHEET
		4:1	3 OF 4
			REV C2

THIS DRAWING IS UNPUBLISHED.

RELEASED FOR PUBLICATION

© COPYRIGHT - BY -

ALL RIGHTS RESERVED.

LOC - DIST -

REVISIONS

P	LTR	DESCRIPTION	DATE	DWN	APVD
-	-	SEE SHEET 1	-	-	-

CODING KEY FOR PRODUCT ORIENTATION

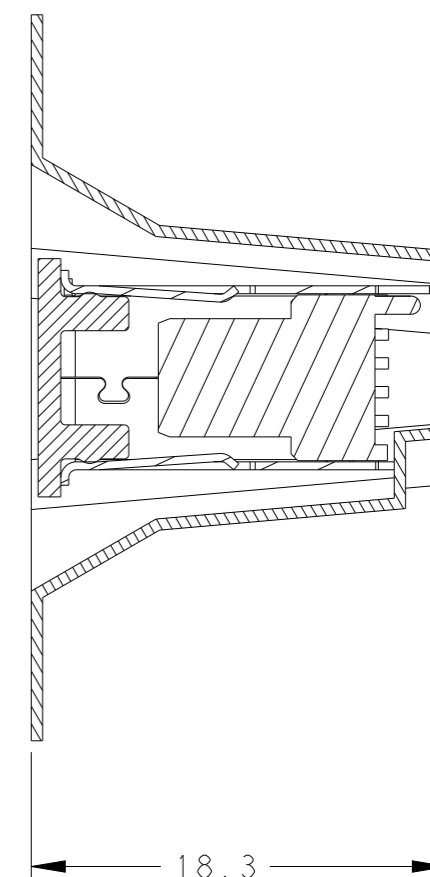
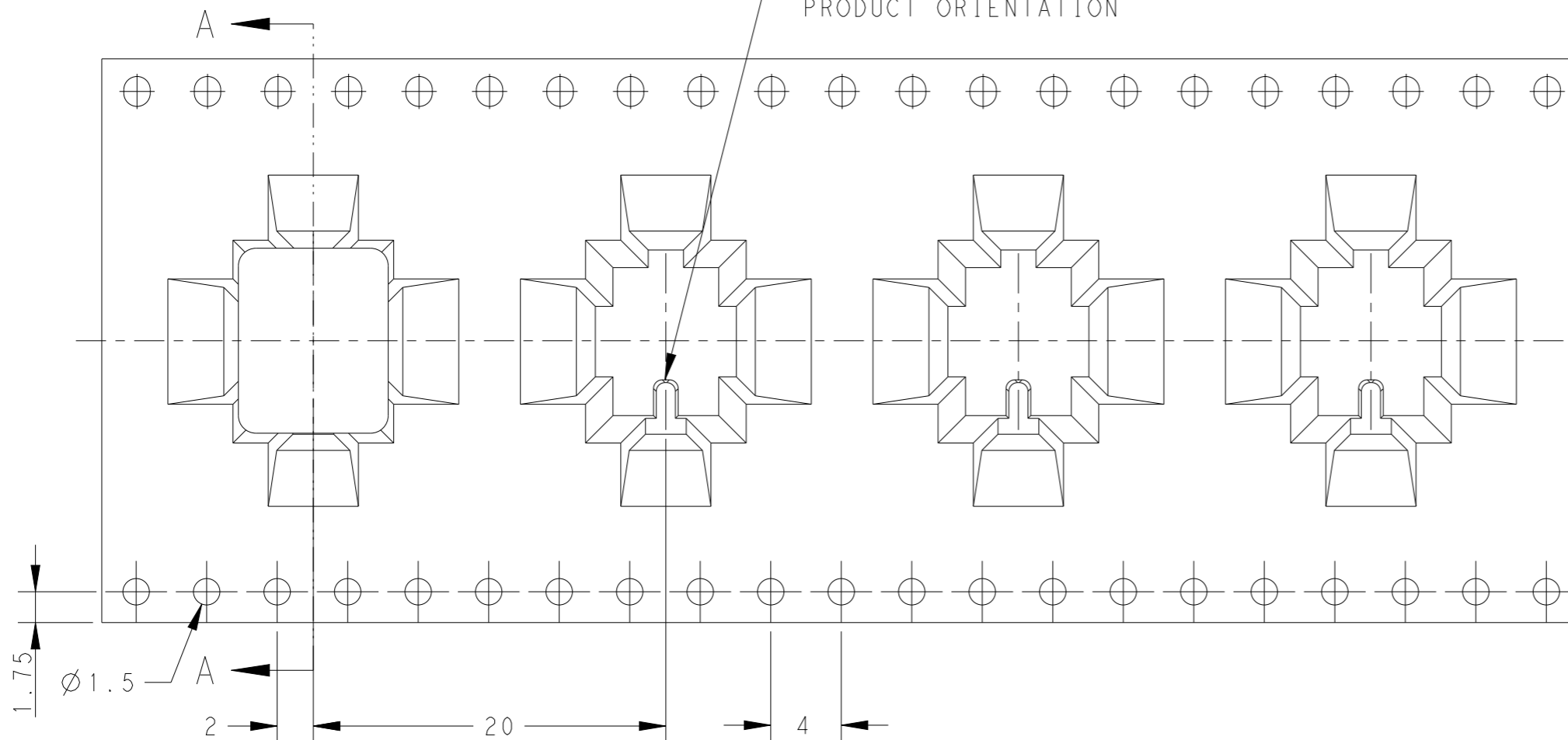

SECTION A - A



EMBOSS TAPE

PACKAGE AS SHOWN	3-2271656-2
	3-2271656-1
	2-2271656-2
	2-2271656-1
DESCRIPTION	PART NO

NOTE:
 6 PACKAGE:
 240PCS PER REEL FOR 2-2271656-1, 2-2271656-2,
 3-2271656-1 & 3-2271656-2

THIS DRAWING IS A CONTROLLED DOCUMENT.		DWN	01DEC2015	 TE Connectivity	NAME SMT VERTICAL MINI I/O RECEPTACLE 1.27mm PITCH
DIMENSIONS: mm		CHK	01DEC2015		
		APVD	01DEC2015		
TOLERANCES UNLESS OTHERWISE SPECIFIED:		PRODUCT SPEC	108-106087		
0 PLC ±- 1 PLC ±- 2 PLC ±- 3 PLC ±- 4 PLC ±- ANGLES ±- MATERIAL - FINISH -		APPLICATION SPEC	-	SIZE	A3
MATERIAL - FINISH -		WEIGHT	-	CAGE CODE	-
-		CUSTOMER DRAWING	-	DRAWING NO	©-2271656
-		SCALE	4:1	RESTRICTED TO	-
-		SHEET	4 OF 4	REV	C2