

VHER-...-B43...(-B)

Hand lever valve

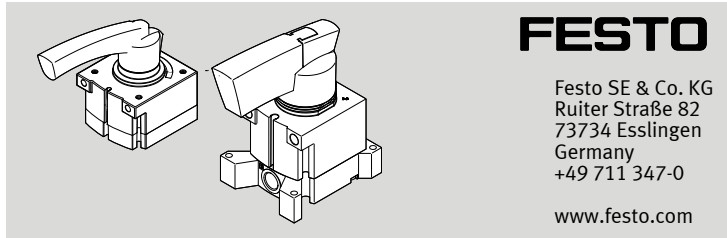

Operating instructions

8150268
2021-01b
[8150270]



Translation of the original instructions

© 2021 all rights reserved to Festo SE & Co. KG

1 Applicable documents

All available documents for the product → www.festo.com/sp.

Document	Product	Table of contents
Operating instructions	Proximity switch SME-10-S.../K...	-

Tab. 1

2 Safety

2.1 Safety instructions

- Only use the product in original status without unauthorised modifications.
- Only use the product if it is in perfect technical condition.
- Before working on the product, switch off the power supply and secure it against being switched on again.

2.2 Intended use

The hand lever valve is intended for manual control of cylinders with compressed air.

2.3 Training of qualified personnel

Work on the product may only be carried out by qualified personnel who can evaluate the work and detect dangers. The qualified personnel have skills and experience in dealing with electropneumatic (open-loop) control technology.

3 Additional information

- Accessories → www.festo.com/catalogue.

4 Product Range Overview

4.1 Scope of delivery

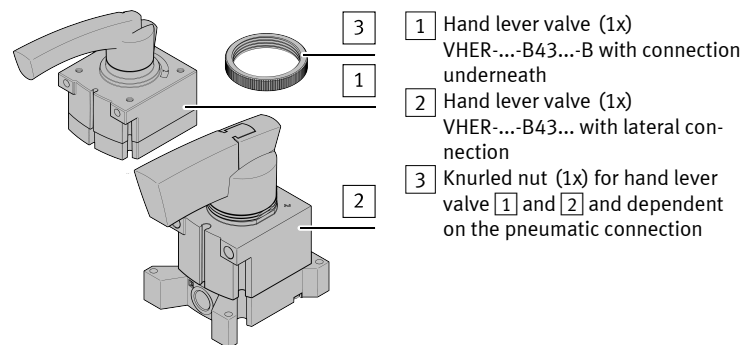

Fig. 1

5 Assembly

5.1 Mounting the proximity switches

1. Move the lever of the hand lever valve 1/2 to the position to be sensed.

2. Select the permissible proximity switch.

Hand lever valve	Sensor slot	Proximity switch
		SME-10-KL-LED-24 SME-10-SL-LED-24
VHER-...-B43...-B	Left	•
	Middle	•
	Right	•
VHER-...-B43...	Left	•
	Middle	-
	Right	•

Tab. 2

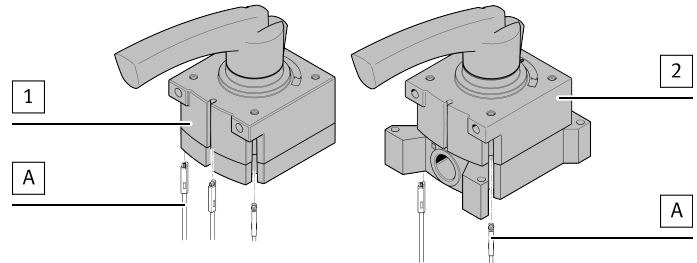

Fig. 2

- Push proximity switch [A] into the sensor slot of the hand lever valve 1/2.

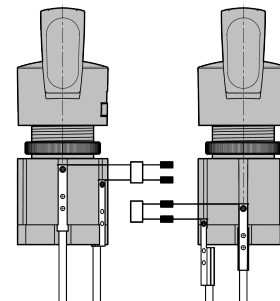

Fig. 3

1. Adjust proximity switch [A] in the positioning range.



The two switch-on ranges are the switching ranges in which the proximity switch switches are on. The positioning ranges are situated at the edges of the switch-on ranges. The proximity switch must be positioned at one of the four positioning ranges. Depending on the hand lever valve, it is possible that the proximity switch cannot be fastened at all four positioning ranges.

Signal from the proximity switch matches the switching position.

2. Tighten the screw of the proximity switch [A]. Tightening torque → 1 Applicable documents.

5.2 Mounting the hand lever valve

5.2.1 Flange mounting

Requirement:

- Unevenness of the substrate ≤ 0.5 mm.

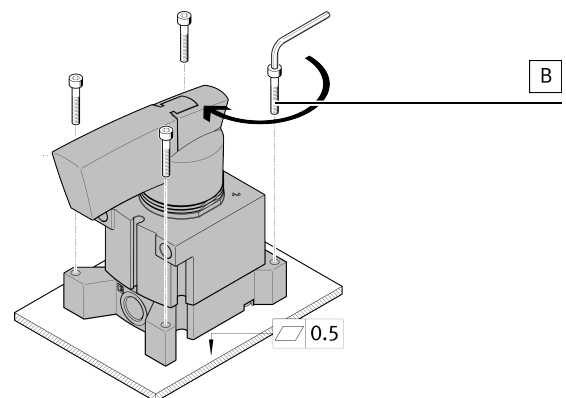

Fig. 4

1. Position hand lever valve 2.

2. Tighten screws [B].

Hand lever valve	Screw [B]	Tightening torque
		[Nm]
VHER...-B43...-M5	M2.5x15	0.5 ± 30 %
VHER...-B43...-G18/-N18	M3x30	1.0 ± 30 %
VHER...-B43...-G14/-N14	M4x25	2.0 ± 20 %
VHER...-B43...-G12/-N12	M5x35	4.0 ± 20 %

Tab. 3

5.2.2 Mounting on front plate with screws

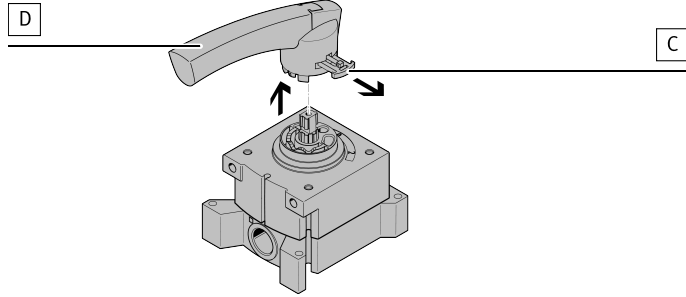

Fig. 5

1. Pull out clamp [C].
2. Remove the lever [D].

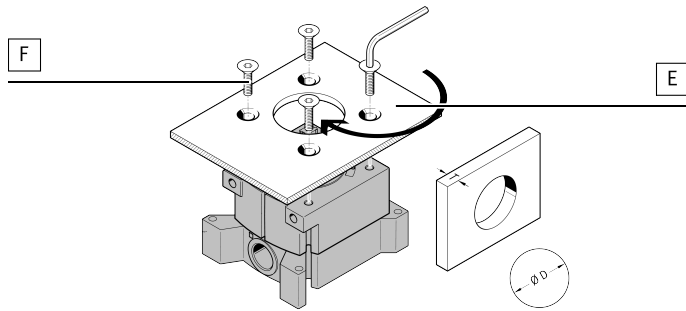

Fig. 6

1. Position hand lever valve 1/2 on the front plate [E].

Hand lever valve	T	$\varnothing D^{+0.2}$
	[mm]	[mm]
VHER...-B43...(-B)-G14/-N14	2 ... 10	40.3
VHER...-B43...(-B)-G12/-N12	2 ... 4	50.3

Tab. 4

2. Tighten screws [F].

Hand lever valve	Screw [F]	Tightening torque	Thread depth
		[Nm]	[mm]
VHER...-B43...(-B)-G14/-N14	M5	4.0 ± 20 %	12
VHER...-B43...(-B)-G12/-N12	M6	8.0 ± 20 %	13

Tab. 5

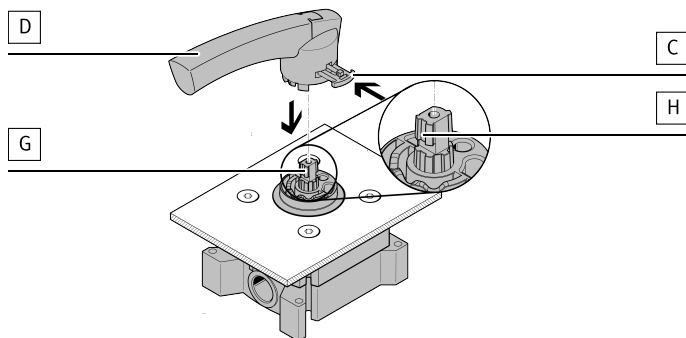

Fig. 7

1. Place the lever [D] on the pin [G].
2. Make sure that the clamp groove [H] is correctly aligned.
3. Push clamp [C] back into the clamp groove [H].
 ↳ The lever [D] is attached.

5.2.3 Mounting on front plate with knurled nut

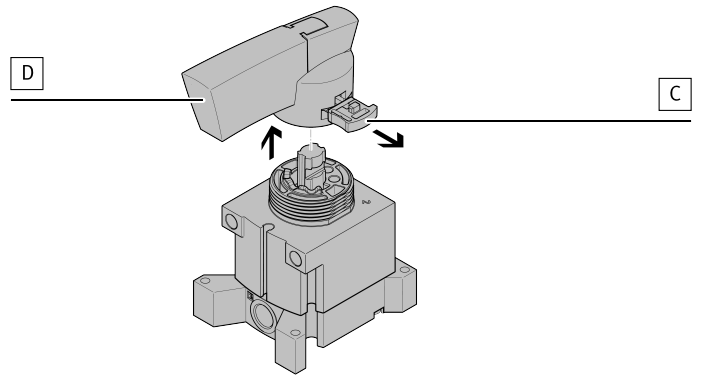

Fig. 8

1. Pull out clamp [C].
2. Remove the lever [D].

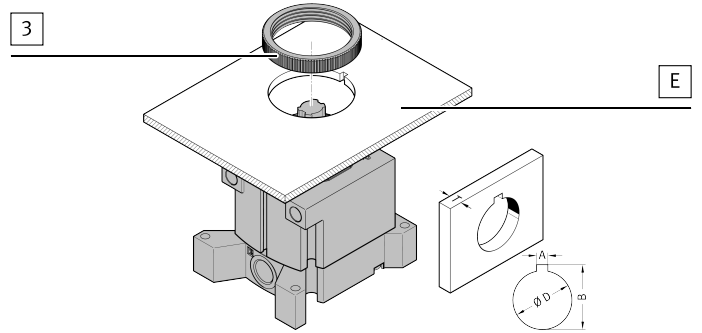

Fig. 9

1. Position hand lever valve 1/2 on the front plate [E].

Hand lever valve	T	$\varnothing D^{+0.2}$	$A^{+0.1}$	$B^{+0.2}$
	[mm]	[mm]	[mm]	[mm]
VHER...-B43...(-B)-M5	1.5 ... 5	22.3	2.6	23.5
VHER...-B43...(-B)-G18/-N18	2 ... 4	30.3	3.1	31.5

Tab. 6

2. Fasten knurled nut [3].

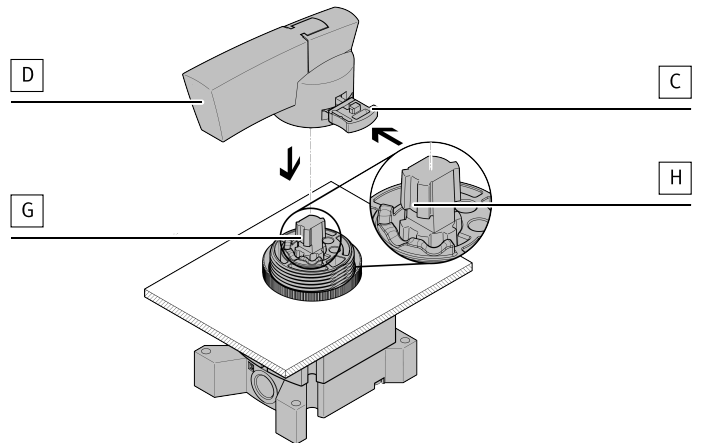

Fig. 10

1. Place the lever [D] on the pin [G].
2. Make sure that the clamp groove [H] is correctly aligned.
3. Push clamp [C] back into the clamp groove [H].
 ↳ The lever [D] is attached.

6 Repair

Send the product to the Festo repair service for repair.