

VPPE-3-1-1/8-...-E1

Proportional-pressure regulator

FESTO

Festo SE & Co. KG
 Rüter Straße 82
 73734 Esslingen
 Germany
 +49 711 347-0

www.festo.com

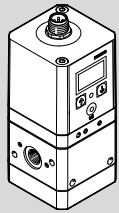

Operating instructions

8136809
 2021-01e
 [8136811]



Translation of the original instructions

© 2021 all rights reserved to Festo SE & Co. KG

1 Applicable Documents

All available documents for the product → www.festo.com/sp.

2 Safety

2.1 Safety instructions

- Only use the product in original status without unauthorised modifications.
- Only use the product if it is in perfect technical condition.
- Take into consideration the ambient conditions at the location of use.
- Before working on the product, switch off the power supply and secure it against being switched on again.

2.2 Intended use

The proportional-pressure regulator is intended to regulate a pressure proportional to a specified setpoint value. The product is intended for use in industrial environments.

2.3 Training of qualified personnel

Work on the product may only be carried out by qualified personnel who can evaluate the work and detect dangers. The qualified personnel have skills and experience in dealing with electropneumatic (open-loop) control technology.

2.4 Approvals

In combination with the UL inspection mark on the product, the information in this section must also be observed in order to comply with the certification conditions of Underwriters Laboratories Inc. (UL) for USA and Canada.

UL certification information

Product category code	QUYX, QUXX7
File number	E322346
Considered standards	UL 610101, CAN/CSAC22.2 No. 61010-1
UL mark	

Tab. 1

- The unit shall be supplied by a power source which fulfils the requirements on a limited-energy circuit in accordance to IEC/EN/UL/CSA 61010-1 or on a Limited Power Source (LPS) in accordance to IEC/EN/UL/CSA 60950-1 or IEC/EN/UL/CSA 62368-1 or a Class 2 circuit in accordance to NEC or CEC.

Electrical data and ambient conditions

Supply voltage	24 V DC
Max. power	4.2 W
Rated pressure	up to 1.1 MPa
Max. installation height	2000 m

Tab. 2

3 Further information

- Accessories → www.festo.com/catalogue.
- Spare parts → www.festo.com/spareparts.

4 Service

Contact your regional Festo contact person if you have technical questions
 → www.festo.com.

4.1 Function

4.1.1 Functional principle

The VPPE... is intended for regulating pressure proportionally to a specified setpoint value. Manually adjustable pressure regulators can be replaced by remotely adjustable electric closed-loop controllers. This allows various machine parameters to be available quickly and automatically.

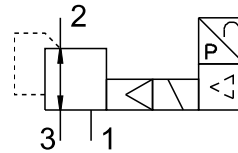
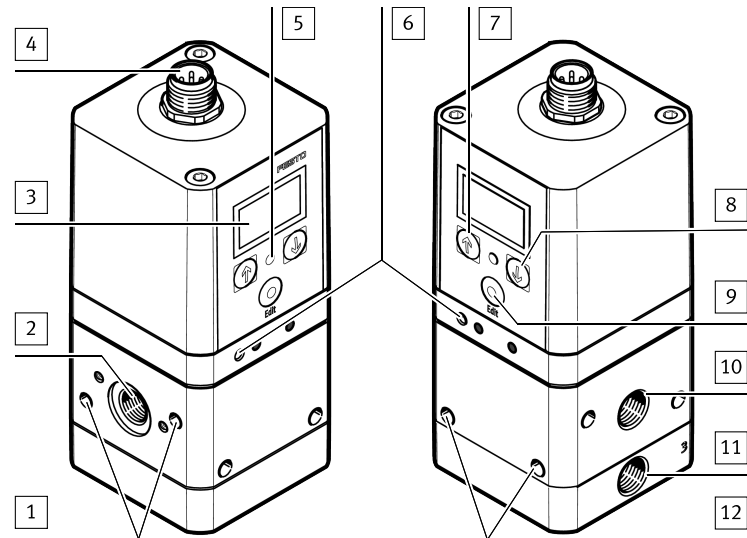

Fig. 1

4.2 Configuration

4.2.1 Product design



- | | |
|---|------------------------|
| 1 Side mounting hole | 7 Up arrow button |
| 2 Input supply port | 8 Down arrow button |
| 3 LED display | 9 EDIT button |
| 4 Electrical connection | 10 Output supply port |
| 5 Status LED | 11 Exhaust supply port |
| 6 Earth terminal, external (front and back) | 12 Front mounting hole |

Fig. 2 Product design VPPE-...-E1

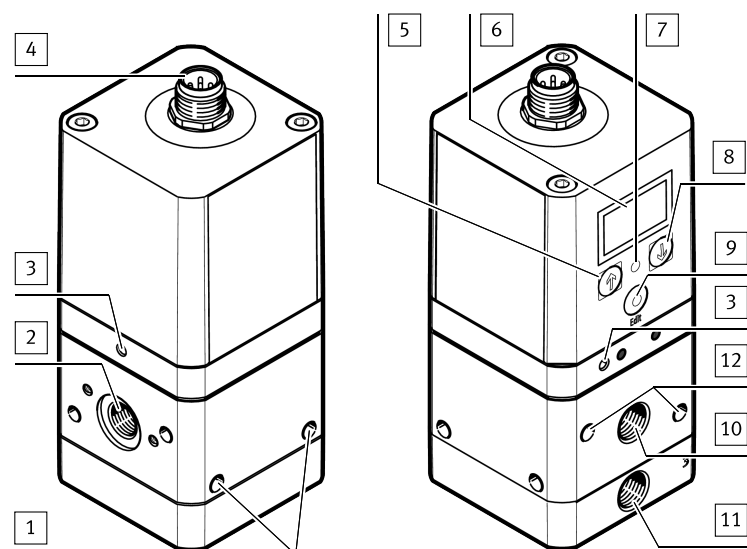

- | | |
|---|------------------------|
| 1 Side mounting hole | 7 Status LED |
| 2 Input supply port | 8 Down arrow button |
| 3 Earth terminal, external (front and back) | 9 EDIT button |
| 4 Electrical connection | 10 Output supply port |
| 5 Up arrow button | 11 Exhaust supply port |
| 6 LED display | 12 Front mounting hole |

Fig. 3 Product design VPPE-...-E1T

5 Mounting

- Place the VPPE-... as close to the consumer as possible. This improves control precision and reduces response times.
- Push two screws (M4) into the holes for lateral mounting → Fig.2, [1] or the holes for front mounting → Fig.2, [12], max. tightening torque: 2 Nm.
- Mount the VPPE-... in the intended position.

NOTICE!

- When installing the VPPE-...-E1T on the mounting rail IPM-PN-08-40x80-AL, note that the compressed air supply corresponds to the total air consumption. For more information see the assembly instructions for the VAME-PS-MK.

6 Installation

6.1 Pneumatic installation

- Remove the covers from the supply ports.
- Attach the tubing to the following ports (→ Fig.2):
Input supply port (1), position [2]
Output supply port (2), position [10]
- Mount a silencer at the exhaust supply port (3) (position [11]) or extract the exhaust air using ducts.

Operating medium

NOTICE!

Too much residual oil content in the compressed air will reduce the service life of the valve.

- When using organic oils (oils that are based on synthetic esters or native esters, e.g. rapeseed oil methyl ester), the maximum residual oil content of 0.1 mg/m³ must not be exceeded (→ Compressed air to ISO 8573-1:2010 [-:-:2]).

The position of the pneumatic ports depends on the variant ordered.

6.2 Electrical installation

⚠ WARNING!

Risk of injury due to electric shock.

- For the electrical power supply, use only PELV circuits in accordance with IEC 60204-1/EN 60204-1 (Protective Extra-Low Voltage, PELV).
- Observe the general requirements of IEC 60204-1/EN60204-1 for PELV circuits.
- Only use voltage sources that ensure a reliable electric separation from the mains network in accordance with IEC 60204-1/EN 60204-1.
- Use the following connection accessories (→ 3 Further information):
 - plug socket with cable or
 - plug socket cable, pre-assembled.

This ensures that the specified degree of protection IP 65 and EMC is achieved.

NOTICE!

To guarantee EMC safety, the device must be earthed as follows:

- Use the earth terminal (→ Fig.2, → Fig.3).
- Use the following earthing accessories (included in the scope of delivery):
 - Self-tapping screw
 - Flat plug
 - Contact washer.

- Wire the VPPE-... in accordance with the plug pattern. Preferably use Festo cables.

	Pin	Colour ¹⁾	Allocation
	1	brown	+24 V DC
	2	white	Analogue input - setpoint value/-w
	3	blue	GND
	4	black	Analogue input - setpoint value/+w (0 ... 10 V or 4 ... 20 mA)
	5	grey	Switching output (24 V) or Analogue output (0 ... 10 V or 4 ... 20 mA) Actual value/X _{OUT}

1) Colour is only valid for Festo accessory cables

Tab. 3 Pin allocation M12x1 plug, 5-pin

7 Commissioning

NOTICE!

- The VPPE-... interprets setpoint signals less than 0.1 V as 0 V and setpoint signals less than 4.16 mA as 4 mA. In this case, the output pressure is set to 0 MPa by activation of the exhaust valve. As a result, a defined valve condition is assured at w = 0.
- Safety position: if the voltage variant setpoint value cable breaks, the output pressure is set to 0 MPa. If the current variant cable breaks or if the supply voltage fails, the output pressure is maintained uncontrolled. Leakage results in a change of pressure over the long term.

- Connect the VPPE-... with a setpoint value signal. The VPPE has a so-called "differential input". The setpoint signal is applied to the contact pin 2 and pin 4, where the lower potential must be connected to the contact pin 2 and the higher potential to the contact pin 4.
Contact pin 2 (- setpoint value) can be connected to contact pin 3 (GND).
- Energise the VPPE-... with direct current (supply voltage U_V = 24 V DC ± 10%).
- Pressurise the VPPE-... to at least 0.1 MPa higher input pressure (p₁) than the maximum desired output pressure. This sets proportional output pressure (p₂).

The following output pressure range is then allocated to the setpoint value signal range 0 ... 10 V or 4 ... 20 mA:

Setpoint value signal range	Output pressure range of the variant		
	0.2 MPa	0.6 MPa	1 MPa
0 ... 10 V or 4 ... 20 mA	0.002 ... 0.2 MPa	0.006 ... 0.6 MPa	0.01 ... 1 MPa

Tab. 4 Setpoint value signal range and associated output pressure range

7.1 Recommended parameter sets

The valves in all pressure variants are set at the factory to Preset 2.

Preset recommendation	Preset		
	1	2	3
Consumer volume	< 0.5 l	~ 0.5 l	> 0.5 l

Tab. 5 Recommended parameter sets

7.2 VPPE display and meaning

i

In the delivery status the display corresponds to the factory setting

→ 10.1 Reset to factory settings.

Display	Meaning	Description
[An]	Analogue	Output: analogue
[bAr]	bar	Pressure unit
[Eco]	ECO mode	Display shutdown (adjustable)
[Frc]	Force	Manual setpoint specification
[HY]	Hysteresis	Spread, switch difference
[in]	Setpoint value	When the ↑ button is pressed (1 sec.), [in] appears. The setpoint value is displayed when the button is released.
[Loc]	Lock	Input locked with PIN code
[n.Hi]	Switch normally closed	N/C contact (normally closed)
[n.Lo]	Switch normally open	N/O contact (normally open)
[OFS]	Offset	Zero point increase (Outlet pressure without setpoint value)
[out]	Actual value	When the ↑ button is pressed (1 sec.), [out] appears. The actual value is displayed when the button is released.
[PA]	Kilopascal	Pressure unit (in kPa)
[Pin]	Pin code	Enter value for locking (1 ... 999)
[Pr1]	Preset 1	(→ 7.1 Recommended parameter sets)
[Pr2]	Preset 2	(→ 7.1 Recommended parameter sets)
[Pr3]	Preset 3	(→ 7.1 Recommended parameter sets)
[PSI]	psi	Pressure unit
[rES]	Reset (factory setting)	Switch on device while pressing ↓ + ↑ + Edit buttons. Observe note in section → 10.1 Reset to factory settings.
[rnG]	Range	Pressure range adjustment
[Snr]	Display serial number	Switch on device while pressing ↑ + Edit buttons: 6-digit serial number is displayed, first [xxx.] then [xxx] alternating approx. every 2 sec.
[SOF]	Display software version	Switch on device while pressing ↓ + Edit keys: software version appears
[SP]	Switching point	→ 6.2 Electrical installation
[SP.H]	Switching Point high	Upper switching point → 6.2 Electrical installation
[SP.L]	Switching Point low	Lower switching point → 6.2 Electrical installation
[SP.O.]	Set Point ok	Setpoint value reached → 6.2 Electrical installation
[unL]	Unlock	Lock removed
[]	Threshold value comparator	→ 6.2 Electrical installation
[]	Window comparator	→ 6.2 Electrical installation
[...]	ECO mode activated	A line moves through the display [...] after x seconds (adjustable)

Tab. 6 Indication on display

7.3 Configuring the output

- The display of the actual value at the analogue output [An] is 0 ... 10 V or 4 ... 20 mA depending on the ordered variant.
- If a switching output is selected, the following modes can be selected: threshold value, window comparator or SP.O.

Switching points (SP...) and hysteresis (HY)

The switching point is only active when a threshold value or window comparator is selected.

The value of the hysteresis specifies the tolerance for the deviation before a signal change occurs at the output (Pin 5).

Setting SP.O.

The SP.O. signal indicates that the setpoint value has been reached in the range (+/-) of the set hysteresis.

If the threshold value comparator is set

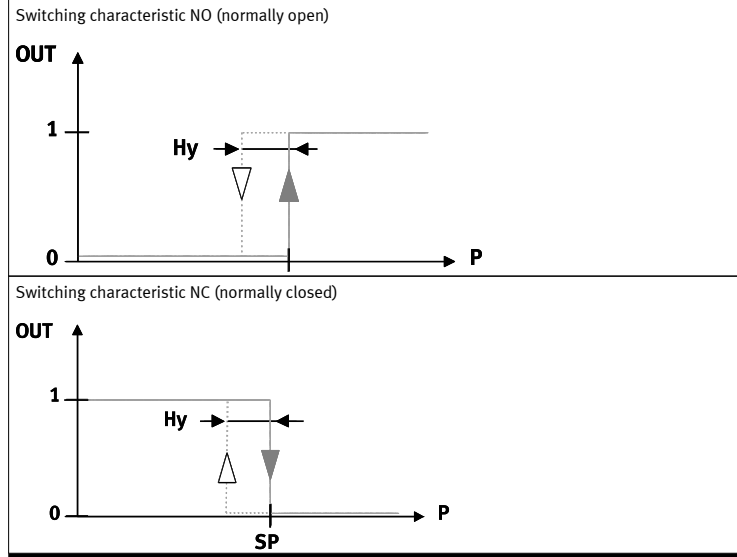

Tab. 7 Window comparator

If SP.O. is selected

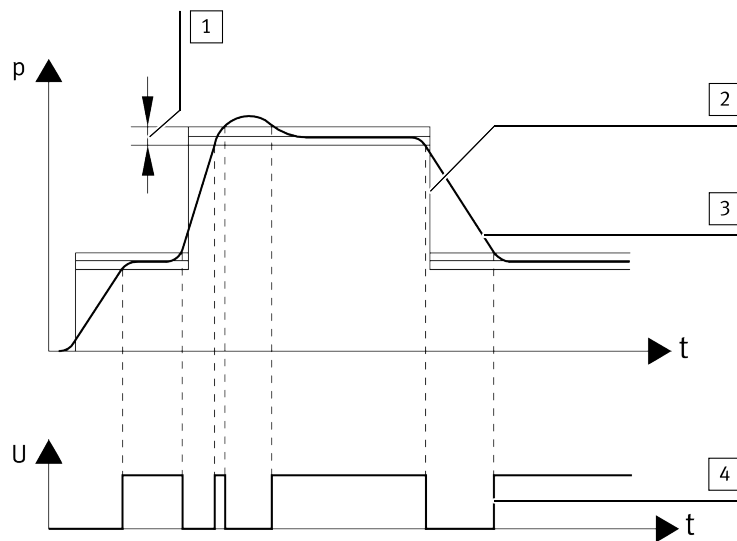

- 1 Hysteresis
- 2 Setpoint value
- 3 Actual value
- 4 SP.O. signal

Fig. 4 If SP.O. is selected

7.4 Display symbols menu

Notes on the following table:

[x.xx] = pressure indicator (actual value or setpoint value)

[...] = input value (with flashing display)

- The main menu selection can be made in only one direction with the Selection button ↓.

- Within a menu option the selection can generally be made with the ↑ or ↓ button.

- If no selection is made within 10 sec. in the main menu or 80 sec. within a menu option, the display automatically jumps back to the initial position, which is exception [Frc].

Menu = main menu selection



[x.xx] = value specification (setpoint value/actual value)

Continue in the menu = press Edit button

If the display flashes (grey background) = you can make a selection with ↑ ↓ buttons

Change value [...] = with ↑ ↓ buttons

Save selection/value = press Edit button

No.	Menu	Selection option ↑ ↓		
1	[x.xx]	↑ (1 sec.) = [in]	↓ (1 sec.) = [out]	
2	[Pr...]			
	[Pr...]	Pr1	Pr2	Pr3
3	[bAr]			
	[bAr]	bAr	PA	PSI
4	[OFS]			
	[...]			
5	[rnG]			
	[...]			
6	[Frc]	0.00 ... 10.0 V (voltage variant) 4.00 ... 20.0 mA (current variant)		
	[...]			
7	[An]			
	[An]			SP.O.
		SP	SP.L	HY
		[...]	[...]	[...]
		[...]	[...]	[...]
		HY	SP.H	[n.Lo/n.Hi]
		[...]	[...]	[n.Lo/n.Hi]
		[...]	[...]	
		[n.Lo/n.Hi]	HY	
		[n.Lo/n.Hi]	[...]	
			[...]	
			n.Lo/n.Hi	
			n.Lo/n.Hi	
8	[Eco]			
	[OFF]			
	[OFF]	[1 ... 999] sec.		
9	[Pin]			
	[OFF]			
	[OFF]	[1 ... 999]		
	back to no. 1			

Tab. 8

7.5 Preparation

8 Operation

NOTICE!

When switching off the VPPE-..., make sure that the setpoint voltage or setpoint current intensity is switched off first, then switch off the supply pressure and finally the supply voltage.

The green status LED lights if the actual value is equal to the setpoint value of within a range of ± 1% (FS) of the setpoint value.

Lock [Loc] - unlock [unL]

If a PIN code was entered with [Pin], [Loc] is shown in the display and the edit mode is locked via the PIN code. If a flashing [0] appears, enter the correct pin. After the correct PIN is entered, [unL] is displayed. If the input is incorrect, the VPPE returns to the initial position.

9 Maintenance

- Clean the housing of the VPPE-... with a soft cloth only. The permitted cleaning medium is a mild detergent solution at max. 50 °C.

10 Malfunctions

Malfunction	Possible cause	Remedy
VPPE ... does not react	No supply voltage, LED not on	Check the connection of the 24 V DC supply voltage
	No setpoint voltage	Check the controller and connection
	VPPE-... fault	Send the device to the Festo repair service
Flow rate too low	Restriction of the flow cross section due to connection technology (swivel fittings)	Use alternative connections
Pressure rise too slow	Large cylinder volume and long tube length	Select different parameter set
Pressure constant despite modified setpoint specification	Supply cable breakage (the last output pressure set is maintained but not regulated). Slow pressure drop due to leakage.	Replace supply cable
	Supply pressure p1 too low	Increase supply pressure

Tab. 9

10.1 Reset to factory settings

NOTICE!

Resetting to the factory settings will lose the current settings.

- If required, make a note of these settings before reset.

Reset [rES] restores the factory setting. Press and hold "↑ + ↓ + Edit" and then switch on the device.

The following parameters are then set:

Parameter	Setting/value
x.xx	Permanent display (actual value/setpoint value)
Pr2	(universal control behaviour)
bar	bar
OFS	000
rnG	for 1 MPa type: 10 for 0.6 MPa type: 6 for 0.2 MPa type: 2
Frc	Display shows existing pressure at pressure output (p2)
An	Output: analogue
Eco	OFF
Pin	OFF

Tab. 10

10.2 Repair

Send the product to the Festo repair service for repair.

11 Technical data

VPPE-3-1-1/8-2-... p1 = 0,4 MPa

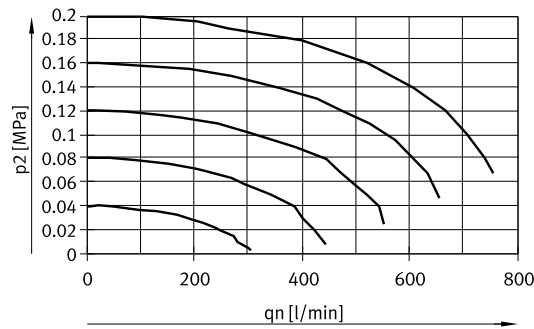

Fig. 5 VPPE-3-1-1/8-2-... p1 = 0.4 MPa

VPPE-3-1-1/8-6-... p1 = 0,8 MPa

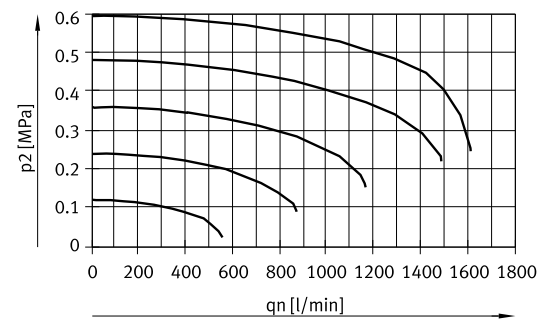

Fig. 6 VPPE-3-1-1/8-6-... p1 = 0.8 MPa

VPPE-3-1-1/8-10-... p1 = 1,1 MPa

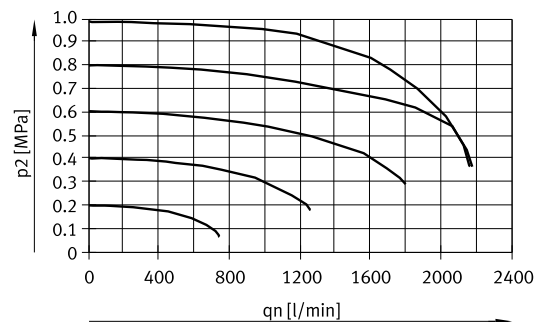

Fig. 7 VPPE-3-1-1/8-10-... p1 = 1.1 MPa

Characteristic values

Mounting position	As desired, preferably vertical (electronics upward).		
Medium	[7:4:4] Lubricated operation not possible		
Pressure regulation range [MPa]	0.002 ... 0.2	0.006 ... 0.6	0.01 ... 1
Permissible input pressure (Input pressure p1 min. 0.1 MPa above output pressure p2)	0.3 ... 0.4	0.6 ... 0.8	0.6 ... 1.1
Standard nominal flow rate	→ Fig.5 to → Fig.7		
Total leakage when new [l/h]	< 5		
Ports	G1/8		
Nominal width			
Pressurisation [mm]	5		
Exhaust [mm]	2.5		
Degree of protection	IP 65 in combination with connector socket according to accessories		
Permissible temperature range			
Environment [°C]	0 ... +60		
Storage [°C]	-10 ... +60		
Medium [°C]	+10 ... +50		
Electrical connection	Pin contact M12x1, 5-pin		
Permitted supply voltage	24 V DC ± 10%		
Setpoint variable input resistance	0 ... +10 V/4 ... 20 mA 10 kΩ (voltage)/250 Ω (current)		
Load actual value output	min. 2 kΩ (voltage) max. 500 Ω (current)		
Residual ripple [%]	10		
Vibration and shock			
Vibration	Tested in accordance with DIN/IEC 68/EN 60068 Part 2-6, Severity level 2		
Shock	Tested in accordance with DIN/IEC 68/EN 60068 Part 2-27, Severity level 2		
Power consumption [W]	max. 4.2		
Electromagnetic compatibility – EMC interference emission and immunity to interference	See declaration of conformity → www.festo.com CE conformity for industrial installations fulfilled		
Materials			
Housing	Al		
Cover	PA		
Seals	NBR		
Lubrication	silicone-free		
Weight [g]	390		

Tab. 11 Characteristic values

Control characteristics

Linearity	1% full scale (FS) at 24 V DC and 25 °C
Hysteresis	
Pressure regulation range 0.002 MPa ... 0.2 MPa	1% full scale (FS)
Pressure regulation range 0.006 MPa ... 0.6 MPa	0.5% full scale (FS)
Pressure regulation range 0.01 MPa ... 1 MPa	0.5% full scale (FS)
Reproducibility	0.5% full scale (FS)
Total accuracy	
Pressure regulation range 0.002 MPa ... 0.2 MPa	1.5% full scale (FS)
Pressure regulation range 0.006 MPa ... 0.6 MPa	1.25% full scale (FS)
Pressure regulation range 0.01 MPa ... 1 MPa	1.25% full scale (FS)
Temperature coefficient	0.04%/K

Tab. 12 Control characteristics

Characteristic values

Design	Proportional-pressure regulator
--------	---------------------------------