

Linear USB Battery Charger with Dual Buck Regulators

DESCRIPTION

Demonstration circuit 1085 is a Linear USB Battery Charger with Dual Buck Regulators featuring the LTC3559. The LTC3559 is a USB battery charger with dual high efficiency buck regulators. The part is ideally suited to power single cell Li-Ion/Polymer based handheld applications needing multiple supply rails.

Battery charge current is programmed via the PROG pin and the HPWR pin, with capability up to 950mA at the BAT pin. The battery charger has an NTC input for temperature qualified charging. The $\overline{\text{CHRG}}$ pin allows battery status to be monitored continuously during the charging process. An internal timer controls charger termination.

Each monolithic synchronous buck regulator provides up to 400mA of output current while operating at efficiencies greater than 90% over the entire Li-Ion/Polymer range. A MODE pin provides the flexibility to place both buck regulators in a power saving burst mode operation or a low noise pulse skip mode.

The LTC3559 is offered in a low profile thermally enhanced 16-lead (3mm × 3mm) QFN package.

Design files for this circuit board are available. Call the LTC factory.

LTC, LTM, LT, Burst Mode, are registered trademarks of Linear Technology Corporation. All other trademarks are the property of their respective owners.

TABLE 1. TYPICAL SPECIFICATIONS (25°C)

Input Voltage Range: V_{CC}	4.35V to 5.5V
VOUT1 @ 25°C	2.5V, ± 2.5%, 400mA (Max)
VOUT2 @ 25°C	1.2V, ± 2.5%, 400mA (Max)
Output Float Voltage V_{BAT} (constant voltage mode)	4.2V
Output Charge Current I_{BAT} (constant current mode)	500mA maximum ($R_{\text{PROG}} = 1.74\text{k}\Omega$ and Jumper HPWR = 100%)

OPERATING PRINCIPLES

The LTC3559 is a linear battery charger with dual monolithic synchronous buck regulators. The buck regulators are internally compensated and need no external compensation components.

The battery charger employs a constant-current constant-voltage charging algorithm and is capable of charging a single Li-Ion battery at charging currents up to 950mA. The user can program the maximum charging current available at the BAT pin

via a single PROG resistor. The actual BAT pin current is set by the status of the HPWR pin.

For proper operation, the BAT and PVIN pins must be tied together. If a buck regulator is also enabled during the battery charging operation, the net current charging the battery may be lower than the actual programmed value.

QUICK START PROCEDURE

Using short twisted pair leads for any power connections and with all loads and power supplies off, refer to Figure 1 for the proper measurement and equipment setup. The Battery should not be connected to the circuit until told to do so in the procedure below.

NOTE. When measuring the input or output voltage ripple, care must be taken to avoid a long ground lead on the oscilloscope probe. Measure the input or output voltage ripple by touching the probe tip directly across the VCC or VOUT and GND terminals. See Figure 2 for proper scope probe technique.

1. Place jumpers in the following positions:

JP1 HPWR = 100%

JP2 EN1 = ON

JP3 EN2 = ON

JP4 MODE = PULSE SKIP

JP5 SUSP = ON

JP6 NTC = INT

2. Connect a battery charged to 3.6 Volts to the demo board as shown in Figure 1.

3. Verify that VOUT1 and VOUT2 are operational with proper output voltages.

4. Once the proper output voltages are established, adjust the loads within the operating range and observe the output voltage regulation, ripple voltage, and efficiency.

5. Set PS1 to 5.0 Volts. Turn on PS1 and verify that the input current measured by ammeter, AM1, does not exceed the USB limit of 500mA.

NOTE. Make sure that the Vcc node does not exceed 6V.

6. Verify that VOUT1 and VOUT2 are operational with proper output voltages.

7. Monitor the PROG voltage for a representation of the battery charge current. $I_{BAT} = 800V / R_{PROG}$

8. Remove the NTC jumper and observe the CHRG LED slow blink rate indicating a temperature fault. Replace the NTC Jumper.

9. Monitor the battery voltage and current (via VPROG) as it charges to its float voltage (4.2 Volts). The CHRG LED will be ON, indicating that the battery is charging until the charge current drops to 1/10th of its programmed value. The charger will continue to supply current into the battery until the 4 hour safety timer has timed out.

APPLICATION INFORMATION

This demo circuit is designed to demonstrate the full capability of the LTC3559 Linear USB Battery Charger with Dual Buck Regulators. Not all components are required in all applications. The critical circuit components are on the top of the board near the IC and listed in the Required Circuit Components section of the Bill of Materials, see Figure 4.

The input capacitor network of C7 and R15 is used to dampen source lead inductances that commonly occur in laboratory setups with twisted leads and a bench power supply. When using a USB cable this input damping network will likely not be required. Please note that the in-circuit capacitance of the specified 10uF, 0805 ceramic capacitor for C7 is less than 5uF with VCC greater than 4.25 Volts.

Capacitor C8 and resistor R12 are included for battery charger stability in float mode when the battery is temporarily not present. Increasing input capacitor C1 to 10uF will allow the part to operate without a battery, provided that the input current limit is not exceeded. A 100uF, 6.3V, OSCON capacitor in a B6 case may be required on the BAT pin when testing is performed with a battery simulator comprised of a power supply with a 3.6 Ohm power resistor across it. Refer

DC1085 QUICK START GUIDE

to the datasheet for more discussion of operation without a battery and the use of ceramic bypass capacitors.

Resistors R4, R5, R13 and R14 are included to allow evaluation of an NTC resistor on or off the board. If R5 is replaced with a 100KΩ, Curve 1, NTC resistor, the demonstration board can be temperature cycled to demonstrate the temperature qualified charging feature of the LTC3559. If the NTC jumper is connected to EXT, the board can be used with an external NTC

resistor between J2-2 and J2-3, such as may be the case when the NTC is incorporated inside a battery pack. If the application calls for a wider temperature range than the standard range set by the internal thresholds, resistors R13 or R14 can be populated with a non-zero valued resistor as described in the datasheet section titled “Alternate NTC Thermistors and Biasing” and R4 or R5 would be changed as needed.

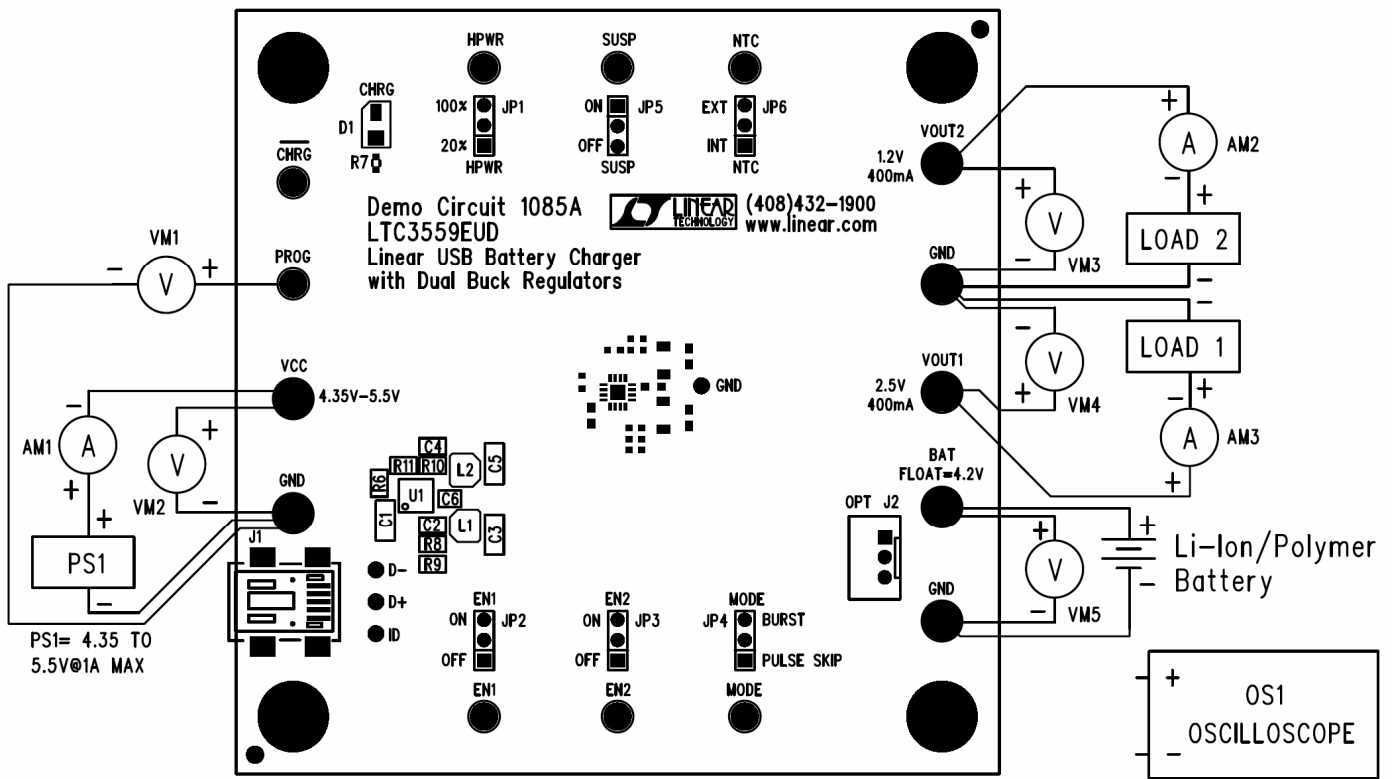

Figure 1. Proper Measurement Equipment Setup

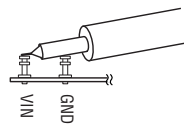

Figure 2. Measuring Input or Output Ripple

DC1085 QUICK START GUIDE

Item	Qty	Reference - Des	Part Description	Manufacturer, Part #
REQUIRED CIRCUIT COMPONENTS:				
1	1	C1	CAP, CHIP, X5R, 1.0uF, 10V, 0603	TDK, C1608X5R1A105K
2	2	C2,C4	CAP, CHIP, COG, 22pF, 50V, 0402	AVX, 04025A220JAT
3	2	C3,C5	CAP, CHIP, X5R, 10uF, 4V, 0603	TDK, C1608X5R0G106M
4	1	C6	CAP, CHIP, X5R, 2.2uF, 6.3V, 0603	TDK, C1608X5R0J225M
5	1	R6	RES, 0402, 1.74K OHM, 1%, 1/16W	VISHAY, CRCW04021K74FKED
6	1	R8	RES, 0402, 665K OHM, 1%, 1/16W	VISHAY, CRCW0402665KFKED
7	1	R9	RES, 0402, 309K OHM, 1%, 1/16W	VISHAY, CRCW0402309KFKED
8	1	R10	RES, 0402, 324K OHM, 1%, 1/16W	VISHAY, CRCW0402324KFKED
9	1	R11	RES, 0402, 649K OHM, 1%, 1/16W	VISHAY, CRCW0402649KFKED
10	2	L1,L2	INDUCTOR, 4.7uH, 0.130 Ohms, 1.3A	TOKO, 1098AS-4R7M
11	1	U1	USB BAT CHARGER WITH DUAL BUCKS	LINEAR TECH, LTC3559EUD
ADDITIONAL DEMO BOARD CIRCUIT COMPONENTS:				
1	0	C7 - OPT	CAP, CHIP, X5R, 10uF, 10V, 0805	MUR, GRM21BR61A106KE19
2	1	C8	CAP, CHIP, X5R, 4.7uF, 6.3V, 0603	MUR, GRM188R60J475KE19D
3	3	R1,R2,R3	RES, 0402, 1.00M OHMS, 1% 1/16W	VISHAY, CRCW04021M00FKED
4	2	R4,R5	RES, 0402, 100K OHMS, 1%, 1/16W	VISHAY, CRCW0402100KFKED
5	1	R12	RES, 0402, 1.0 OHM, 5%, 1/16W	VISHAY, CRCW04021R00JNED
6	2	R13, R14	RES, 0402, 0.0 OHM, 1/16W	VISHAY, CRCW0402000Z0ED
7	0	R15 - OPT	RES, 0402, 1.0 OHM, 5%, 1/16W	VISHAY, CRCW04021R00JNED
8	1	D1	LED, GREEN	PANASONIC, LN1351C-(TR)
9	1	R7	RES, 0402, 510 OHMS, 5%, 1/16W	VISHAY, CRCW0402510RJNED
HARDWARE FOR DEMO BOARD ONLY:				
1	6	JP1,JP2,JP3,JP4, JP5,JP6	HEADER, 3 PINS, 2mm	SAMTEC, TMM-103-02-L-S
2	6	JP1,JP2,JP3,JP4, JP5,JP6	SHUNT, 2mm	SAMTEC, 2SN-BK-G
3	1	J1	CONN, USB MINI-B	TYCO, 1734035-2
4	1	J2	CONN, DF3-3P-2DSA	HIROSE, DF3-3P-2DSA
5	8	E1,E5,E13,E14,E15, E16,E17,E18	TURRET, 0.09 DIA	MILLMAX, 2501-2
6	7	E6,E7,E8,E9,E10, E11,E12	TURRET, 0.061 DIA	MILLMAX, 2308-2
7	4		STAND-OFF, NYLON 0.25" tall (SNAP ON)	KEYSTONE, 8831 (SNAP ON)

Figure 4. Bill of Materials

Mouser Electronics

Authorized Distributor

Click to View Pricing, Inventory, Delivery & Lifecycle Information:

[Analog Devices Inc.:](#)

[DC1085A](#)