

DC Brushless Fan Motor Drivers

Three-phase Full-wave Fan Motor Driver

BD63242EFV

General Description

BD63242EFV is a 1chip driver composed of a Power DMOS FET Motor Driver. It features a sensor-less drive which does not require a hall device as a position detection sensor. Furthermore, it introduces by making output current a sine-wave that achieves silent operation and low vibration.

Features

- Small Package
- Driver Including Power DMOS FET
- Sensor-less Full Sine Drive
- Speed Controllable by DC/PWM Input
- Minimum Output Duty Setting (Only on DC Voltage Input Speed Control.)
- Rotation Direction Select
- Rotation Speed Pulse Signal Output (FG, 1/2FG)
- Protection Function
(Under Voltage Lock Out Protection Function, Lock Protection Function (Automatic Recovery), High Speed Rotation Protection Function and Low Speed Rotation Protection Function)

Application

- Fan Motors for General Consumer Equipment such as Refrigerator etc.

Typical Application Circuit

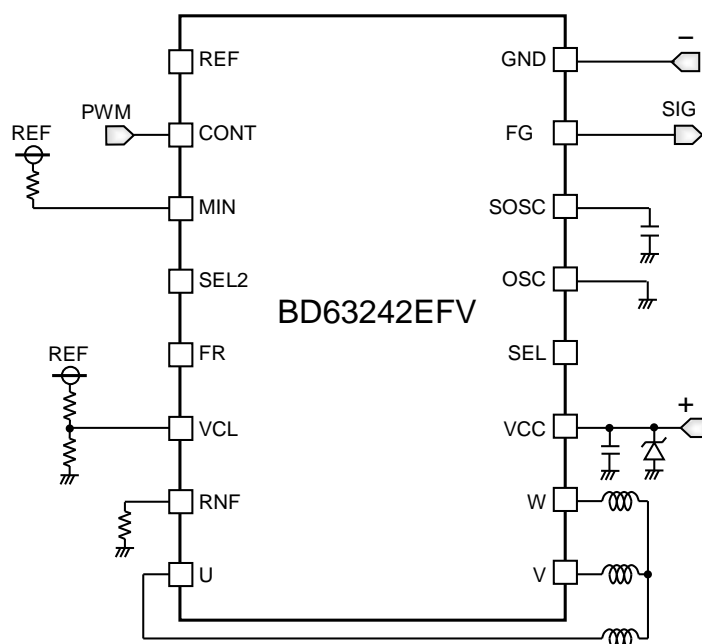

Key Specifications

- Operating Supply Voltage Range: 5.0 V to 16.0 V
- Operating Temperature Range: -40 °C to +100 °C

Package

HTSSOP-B16

W(Typ) x D(Typ) x H(Max)

5.00 mm x 6.40 mm x 1.00 mm

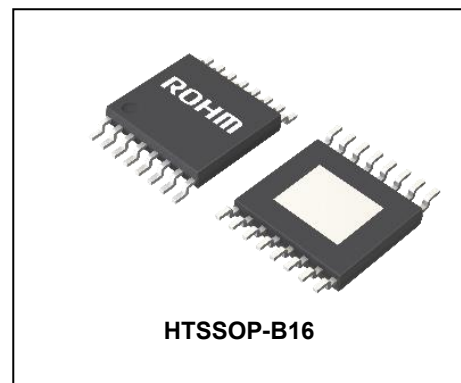

HTSSOP-B16

Contents

General Description	1
Features.....	1
Application	1
Key Specifications	1
Package.....	1
Typical Application Circuit	1
Contents	2
Pin Configuration	3
Pin Descriptions.....	3
Block Diagram	4
Absolute Maximum Ratings	5
Thermal Resistance.....	5
Recommended Operating Conditions.....	5
Electrical Characteristics.....	6
Application Examples	7
Typical Performance Curves.....	8
Description of Function Operations.....	14
Thermal Resistance Model	23
I/O Equivalence Circuits.....	24
Note for Content	24
Location of IC.....	24
Operational Notes.....	25
Ordering Information	27
Marking Diagram	27
Physical Dimension and Packing Information	28
Revision History.....	29

Pin Configuration

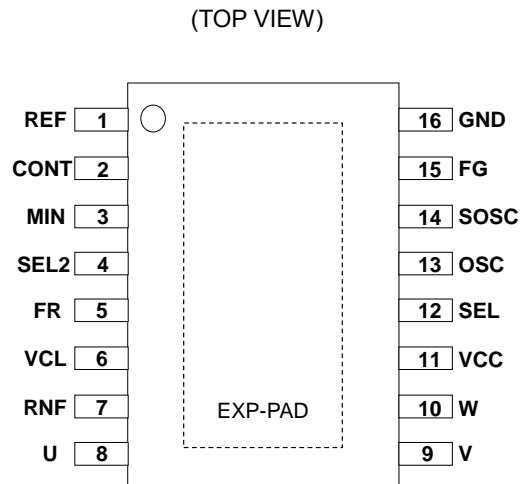

Figure 1. Pin Configuration

Pin Descriptions

Pin No.	Pin Name	Function
1	REF	Reference voltage output pin
2	CONT	Output duty control pin
3	MIN	Minimum output duty setting pin
4	SEL2	Rotation speed pulse signal selection, minimum BEMF detect width setting pin
5	FR	Motor rotation direction setting pin
6	VCL	Current limit setting pin in fixed initial position and forcibly synchronized start-up section
7	RNF	Output current detecting resistor connection pin
8	U	Output U pin
9	V	Output V pin
10	W	Output W pin
11	VCC	Power supply pin
12	SEL	Start-up assist function setting pin
13	OSC	Oscillating capacitor connection pin for OSC frequency setting
14	SOSC	Oscillating capacitor connection pin for output switching frequency setting in forcibly synchronized start-up section
15	FG	Rotating speed pulse signal output pin
16	GND	Ground pin
Reverse	EXP-PAD	Substrate (Connect to Ground)

Block Diagram

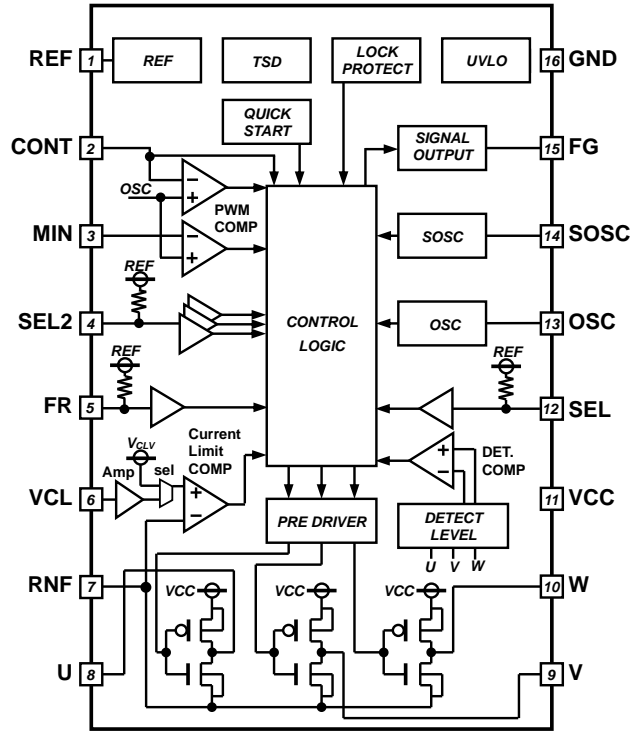

Figure 2. Block Diagram

Absolute Maximum Ratings (Ta=25 °C)

Parameter	Symbol	Rating	Unit
Supply Voltage (VCC)	V _{CC}	20	V
Storage Temperature Range	T _{stg}	-55 to +150	°C
Output Voltage (U, V, W)	V _O	20	V
Output Current (U, V, W)	I _o	1.0 ^(Note 1)	A
FG Output Voltage	V _{FG}	20	V
FG Output Current	I _{FG}	10	mA
Reference Voltage (REF) Output Current	I _{REF}	10	mA
Input Voltage1 (CONT, VCL, FR, SEL, SEL2, MIN)	V _{IN1}	7	V
Input Voltage2 (RNF)	V _{IN2}	4.5	V
Maximum Junction Temperature	T _{jmax}	150	°C

Caution 1: Operating the IC over the absolute maximum ratings may damage the IC. The damage can either be a short circuit between pins or an open circuit between pins and the internal circuitry. Therefore, it is important to consider circuit protection measures, such as adding a fuse, in case the IC is

Caution 2: Should by any chance the maximum junction temperature rating be exceeded the rise in temperature of the chip may result in deterioration of the properties of the chip. In case of exceeding this absolute maximum rating, design a PCB with thermal resistance taken into consideration by increasing board size and copper area so as not to exceed the maximum junction temperature rating.

(Note 1) Do not exceed T_{jmax}

Thermal Resistance^(Note 2)

Parameter	Symbol	Thermal Resistance(Typ)		Unit
		1s ^(Note 4)	2s2p ^(Note 5)	
HTSSOP-B16				
Junction to Ambient	θ _{JA}	131.5	30.8	°C/W
Junction to Top Characterization Parameter ^(Note 3)	ψ _{JT}	9	3	°C/W

(Note 2) Based on JESD51-2A (Still-Air)

(Note 3) The thermal characterization parameter to report the difference between junction temperature and the temperature at the top center of the outside surface of the component package.

(Note 4) Using a PCB board based on JESD51-3.

(Note 5) Using a PCB board based on JESD51-5, 7.

Layer Number of Measurement Board	Material	Board Size
Single	FR-4	114.3 mm x 76.2 mm x 1.57 mmt

Top	
Copper Pattern	Thickness
Footprints and Traces	70 μm

Layer Number of Measurement Board	Material	Board Size	Thermal Via ^(Note 6)	
			Pitch	Diameter
4 Layers	FR-4	114.3 mm x 76.2 mm x 1.6 mmt	1.20 mm	Φ0.30 mm

Top		2Internal Layers		Bottom	
Copper Pattern	Thickness	Copper Pattern	Thickness	Copper Pattern	Thickness
Footprints and Traces	70 μm	74.2 mm x 74.2 mm	35 μm	74.2 mm x 74.2 mm	70 μm

(Note 6) This thermal via connects with the copper pattern of all layers.

Recommended Operating Conditions

Parameter	Symbol	Min	Typ	Max	Unit
Supply Voltage(VCC)	V _{CC}	5	12	16	V
Input Voltage(CONT, VCL, FR, SEL, SEL2, MIN)	V _{IN}	0	-	V _{REF}	V
Input Frequency(CONT)	f _{IN}	10	-	50	kHz
Operating Temperature	Topr	-40	-	+100	°C

Electrical Characteristics (Unless otherwise specified $V_{CC}=12\text{ V}$, $T_a=25\text{ }^\circ\text{C}$)

Parameter	Symbol	Min	Typ	Max	Unit	Conditions
Circuit Current	I_{CC}	4.0	6.6	8.9	mA	
<REF>						
Reference Voltage	V_{REF}	4.65	5.00	5.35	V	$I_{REF}=-2\text{ mA}$
<SOSC>						
SOSC Charge Current	I_{CSOSC}	-55	-44	-33	μA	$V_{SOSC}=0.8\text{ V}$
SOSC Discharge Current	I_{DSOSC}	33	44	55	μA	$V_{SOSC}=0.8\text{ V}$
SOSC Frequency	f_{SOSC}	46.6	64.7	82.8	kHz	$C_{SOSC}=680\text{ pF}$
<CONT, MIN>						
CONT Input High Voltage	V_{CONTH}	2.5	-	V_{REF}	V	PWM Input Mode $V_{OSC}=0\text{ V}$
CONT Input Low Voltage	V_{CONTL}	0.0	-	0.8	V	PWM Input Mode $V_{OSC}=0\text{ V}$
CONT Input Bias Current 1	I_{CONT1}	-75	-50	-25	μA	PWM Input Mode $V_{OSC}=0\text{ V}$, $V_{CONT}=0\text{ V}$
CONT Input Bias Current 2	I_{CONT2}	-1	-	-	μA	DC Input Mode $V_{CONT}=0\text{ V}$
MIN Input Bias Current	I_{MIN}	-1	-	-	μA	$V_{MIN}=0\text{ V}$
<OSC>						
OSC Charge Current	I_{COSC}	-60	-44	-28	μA	$V_{OSC}=1.8\text{ V}$
OSC Discharge Current	I_{DOSC}	28	44	60	μA	$V_{OSC}=1.8\text{ V}$
OSC Frequency	f_{OSC}	28.8	46.0	63.4	kHz	$C_{OSC}=330\text{ pF}$
<Current Limit>						
Current Limit Setting Voltage	V_{CLV}	120	150	180	mV	
<VCL>						
VCL Input Bias Current	I_{VCL}	-1	-	-	μA	$V_{VCL}=0\text{ V}$
<FG>						
FG Output Low Voltage	V_{FGL}	-	0.15	0.40	V	$I_{FG}=5\text{ mA}$
FG Output Leak Current	I_{FGL}	-	-	10	μA	$V_{FG}=20\text{ V}$
<Lock Protection>						
Lock Detection OFF Time	t_{OFF}	3.75	5.00	6.25	s	
<Output>						
Output Voltage	V_O	-	0.3	0.4	V	$I_O=\pm 300\text{ mA}$ High and low side output voltage total
<SEL>						
SEL Input Current	I_{SEL}	-35	-25	-15	μA	$V_{SEL}=0\text{ V}$
SEL Mode 1 Input Voltage	V_{SEL_1}	3.8	-	V_{REF}	V	
SEL Mode 2 Input Voltage	V_{SEL_2}	0.0	-	0.8	V	
<SEL2>						
SEL2 Input Current	I_{SEL2}	-35	-25	-15	μA	$V_{SEL2}=0\text{ V}$
SEL2 Mode 1 Input Voltage	V_{SEL2_1}	3.85	-	V_{REF}	V	
SEL2 Mode 2 Input Voltage	V_{SEL2_2}	2.60	-	3.65	V	
SEL2 Mode 3 Input Voltage	V_{SEL2_3}	1.35	-	2.40	V	
SEL2 Mode 4 Input Voltage	V_{SEL2_4}	0.00	-	1.15	V	
<FR>						
FR Input Current	I_{FR}	-35	-25	-15	μA	$V_{FR}=0\text{ V}$
FR Input High Voltage	V_{FRH}	3.8	-	V_{REF}	V	
FR Input Low Voltage	V_{FRL}	0.0	-	0.8	V	

For parameters involving current, positive notation means inflow of current to the IC while negative notation means outflow of current from the IC

Application Examples

1. Variable Speed Control Application using PWM Duty Converted to DC Voltage.

This is the application example to control rotation speed by the external PWM signal converted to DC voltage. And the MIN pin setting the minimum output duty is possible.

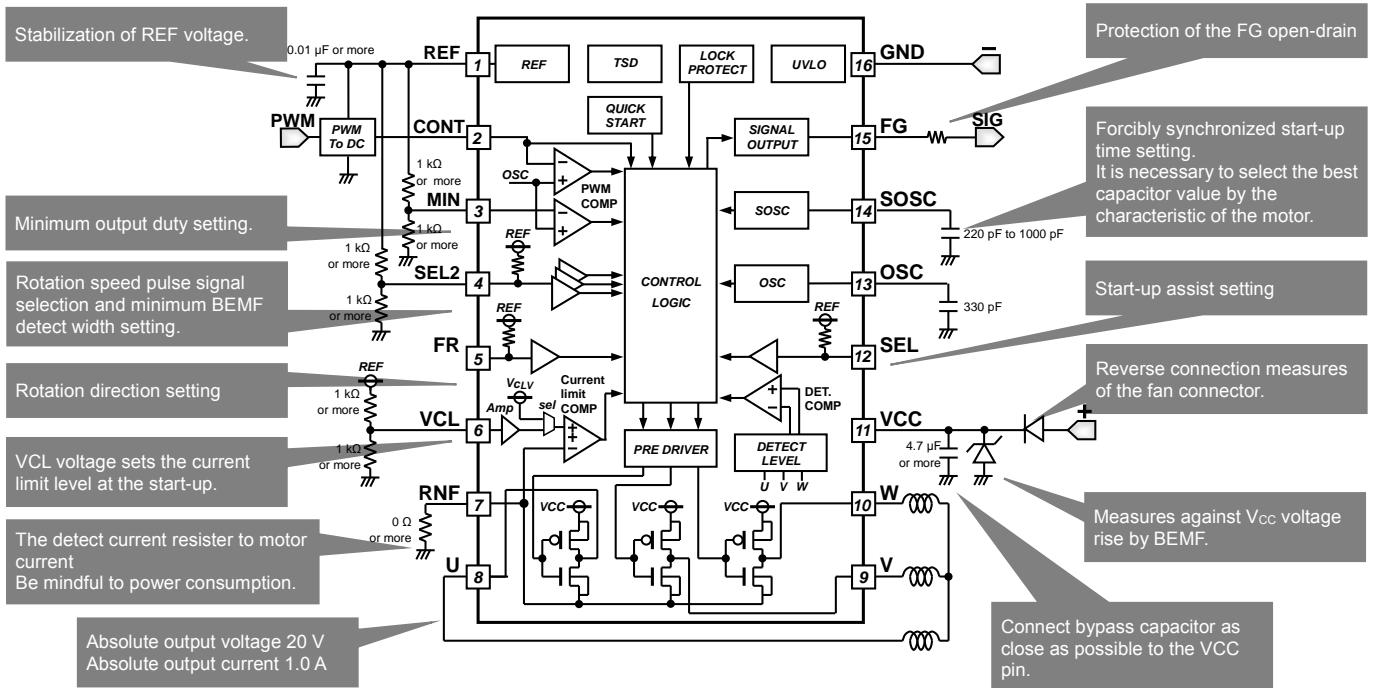

Figure 3. Application of PWM Duty Converted to DC Voltage

2. Variable Speed Control Application by PWM Duty Input

Setting of the minimum output duty is not possible in this application.

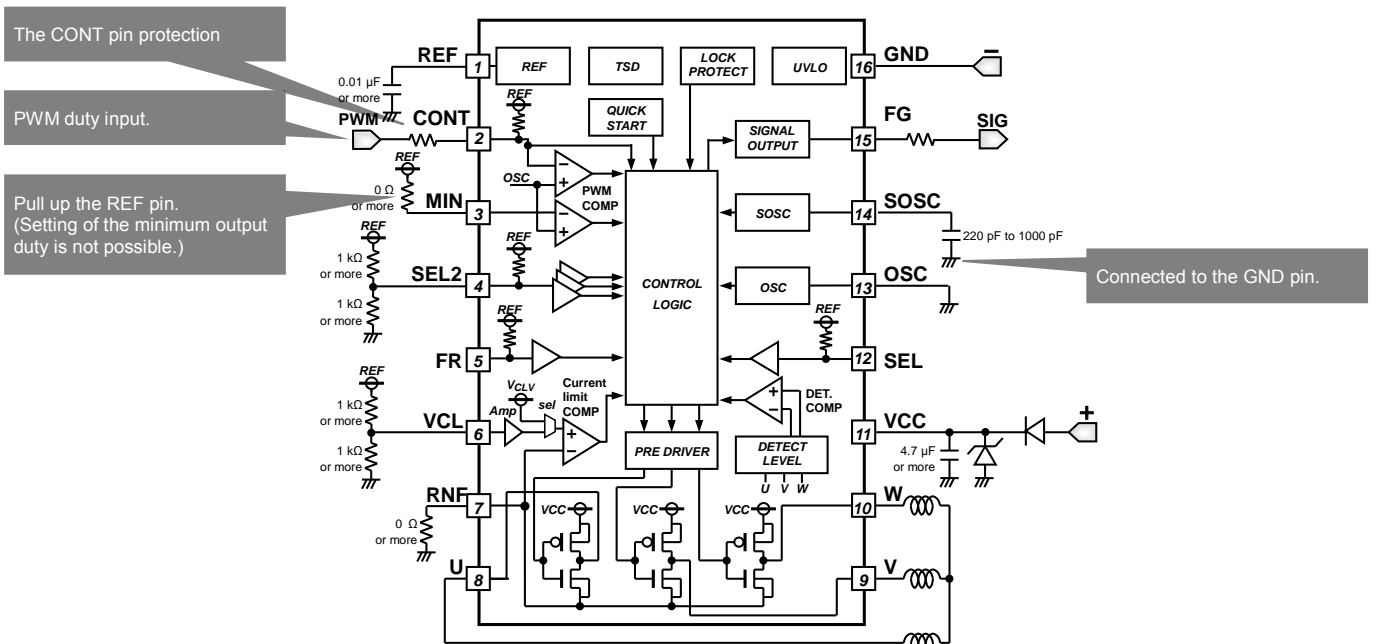

Figure 4. PWM Duty Input Application

Board Design Note

1. IC power (VCC), motor outputs (U, V, W), and motor ground (RNF) lines are made as wide as possible.
2. The IC ground (GND) is common with the application ground except motor ground, and arranged as close as possible to (-) land.
3. The bypass capacitor and the Zener diode are placed as close as possible to the VCC pin.

Typical Performance Curves

(Reference Data)

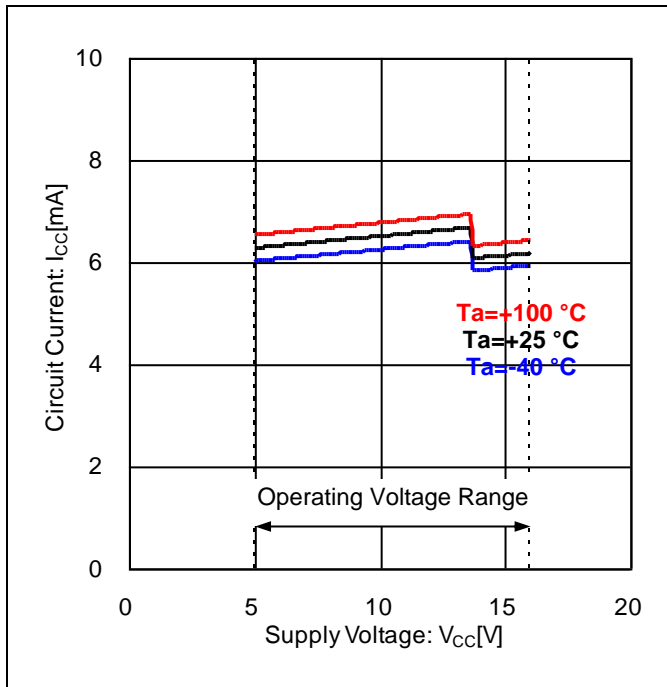

Figure 5. Circuit Current vs Supply Voltage

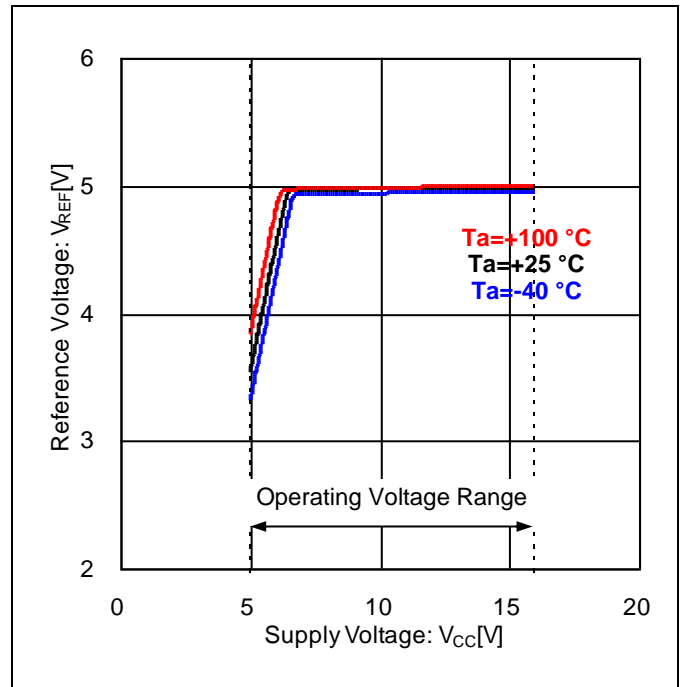

Figure 6. Reference Voltage vs Supply Voltage

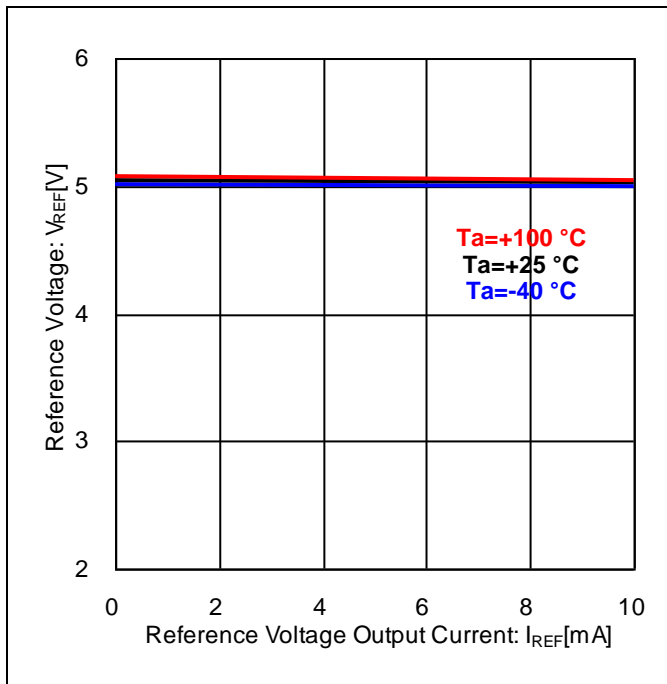

Figure 7. Reference Voltage vs Reference Voltage Output Current (V_{CC}=12 V)

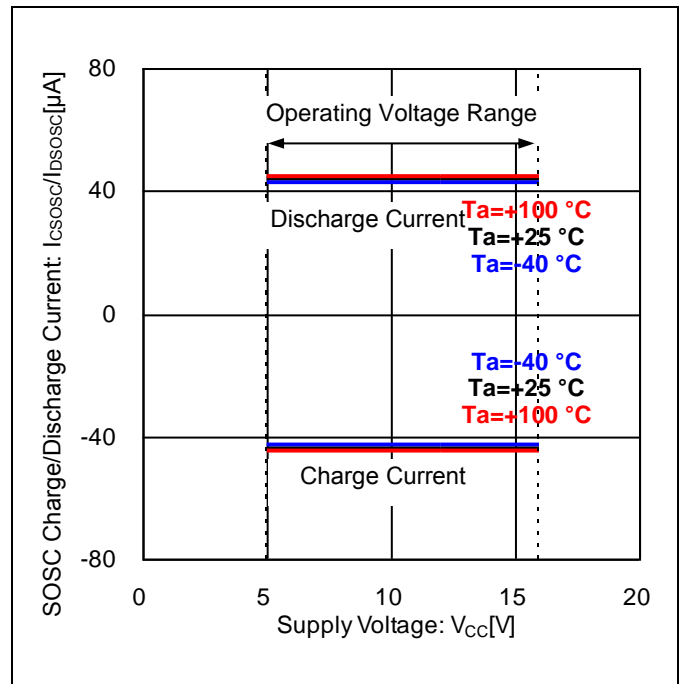

Figure 8. SOSC Charge/Discharge Current vs Supply Voltage

Typical Performance Curves - continued
(Reference Data)

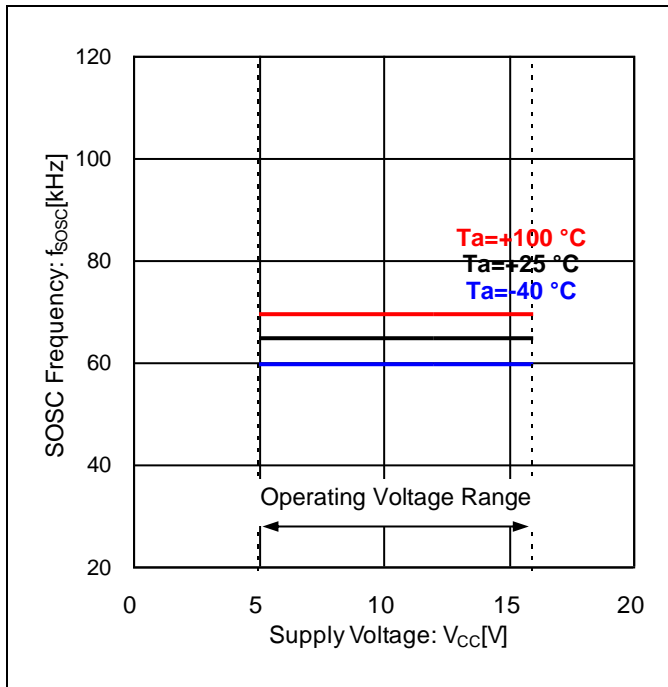

Figure 9. SOSC Frequency vs Supply Voltage
(C_{sosc}=680 pF)

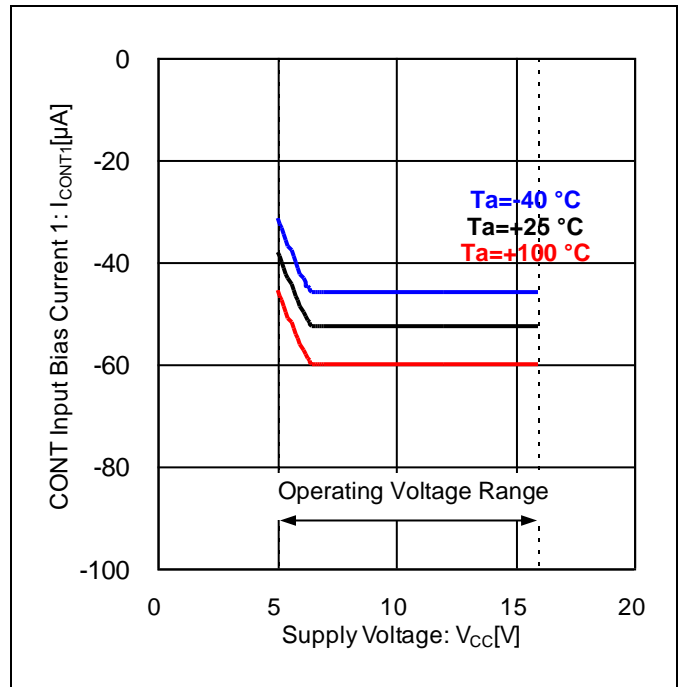

Figure 10. CONT Input Bias Current 1 vs Supply Voltage

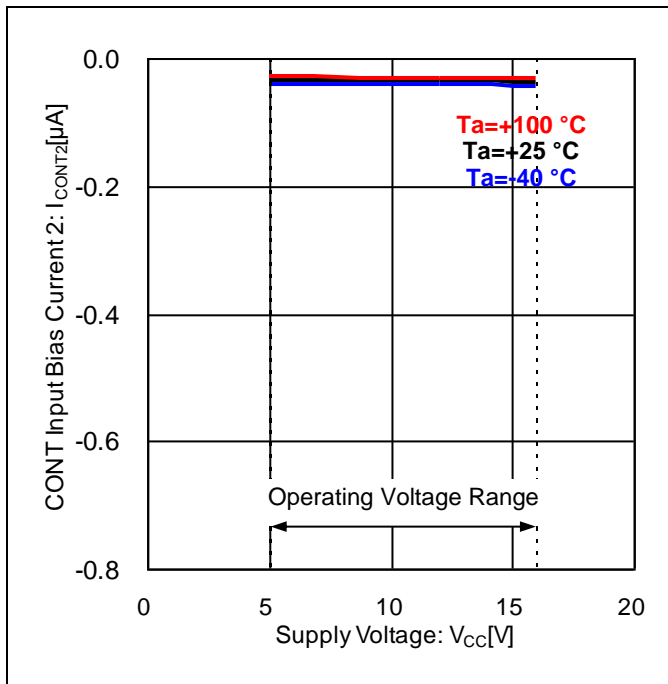

Figure 11. CONT Input Bias Current 2 vs Supply Voltage

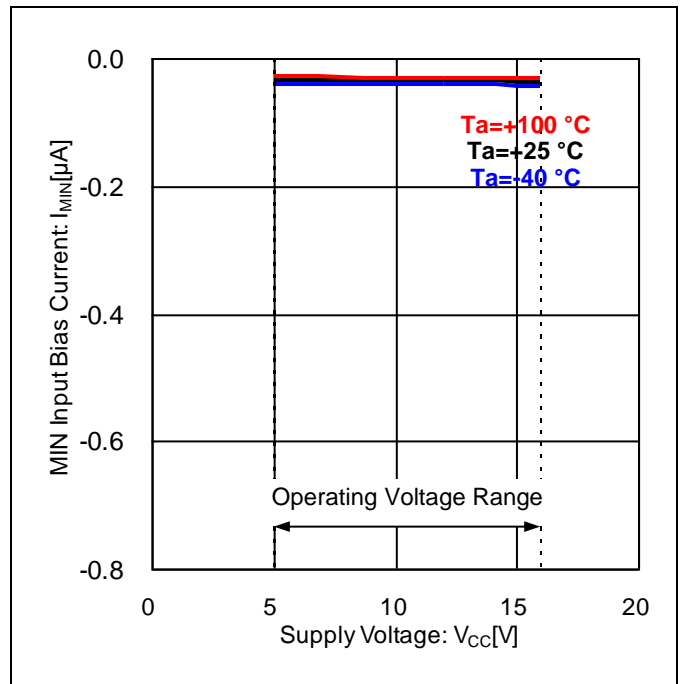

Figure 12. MIN Input Bias Current vs Supply Voltage

Typical Performance Curves - continued
(Reference Data)

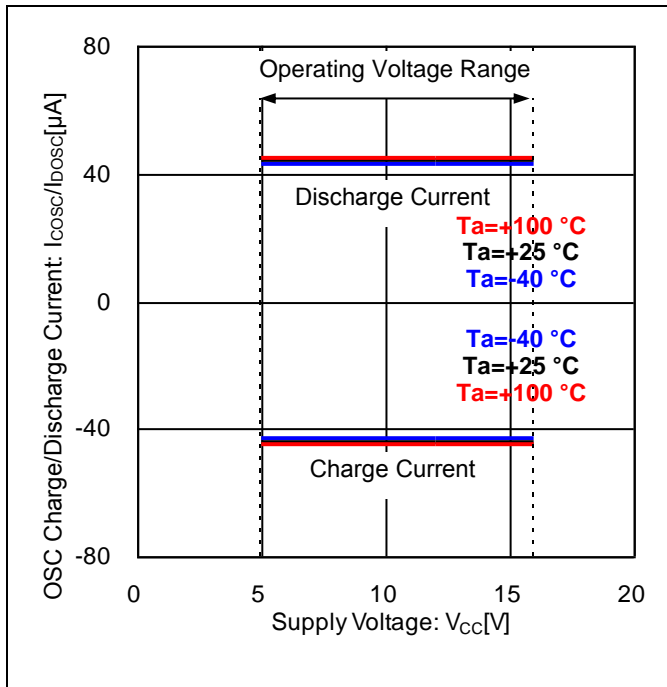

Figure 13. OSC Charge/Discharge Current vs Supply Voltage

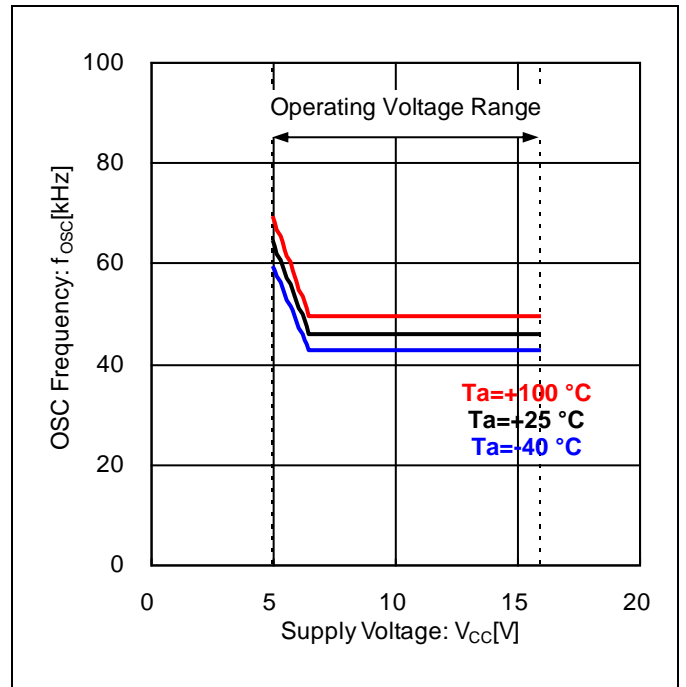

Figure 14. OSC Frequency vs Supply Voltage
(C_{osc}=330 pF)

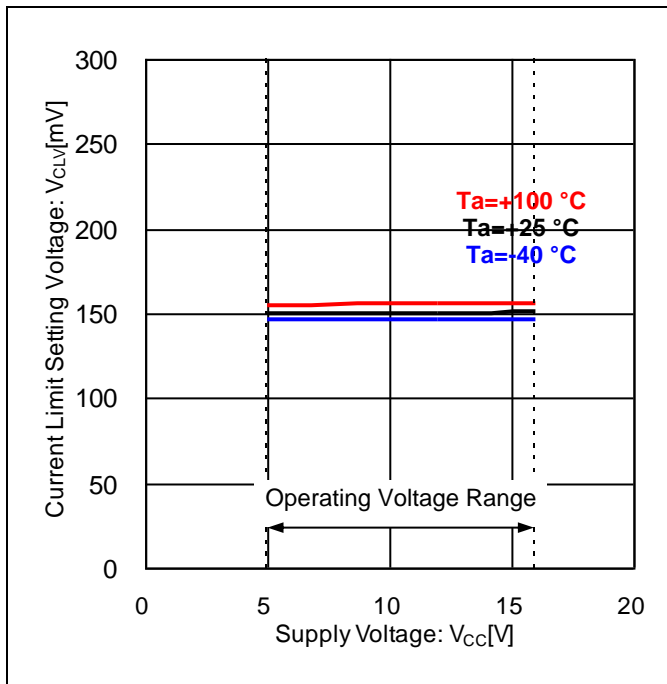

Figure 15. Current Limit Setting Voltage vs Supply Voltage

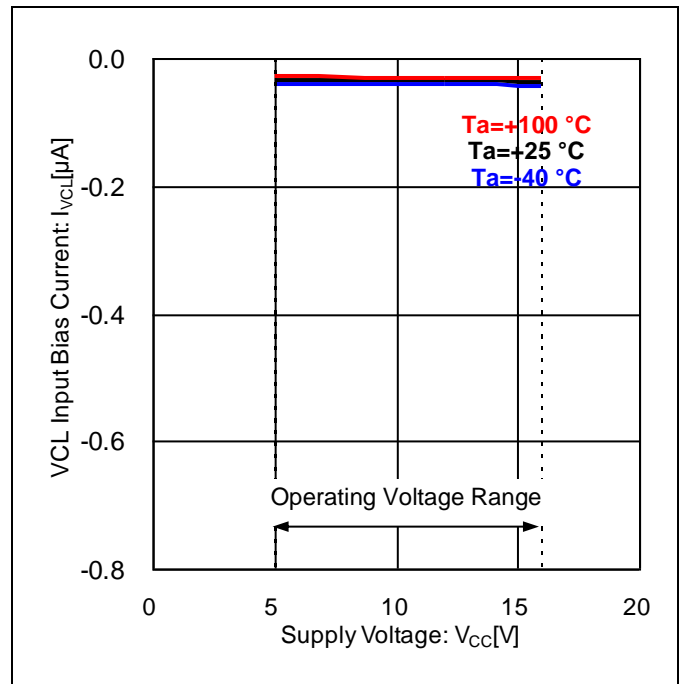

Figure 16. VCL Input Bias Current vs Supply Voltage

Typical Performance Curves - continued
(Reference Data)

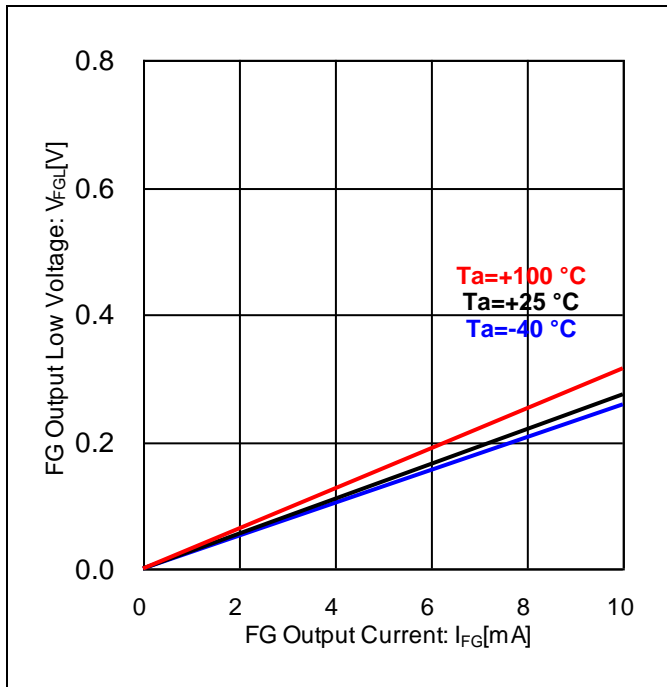

Figure 17. FG Output Low Voltage vs FG Output Current (V_{CC}=12 V)

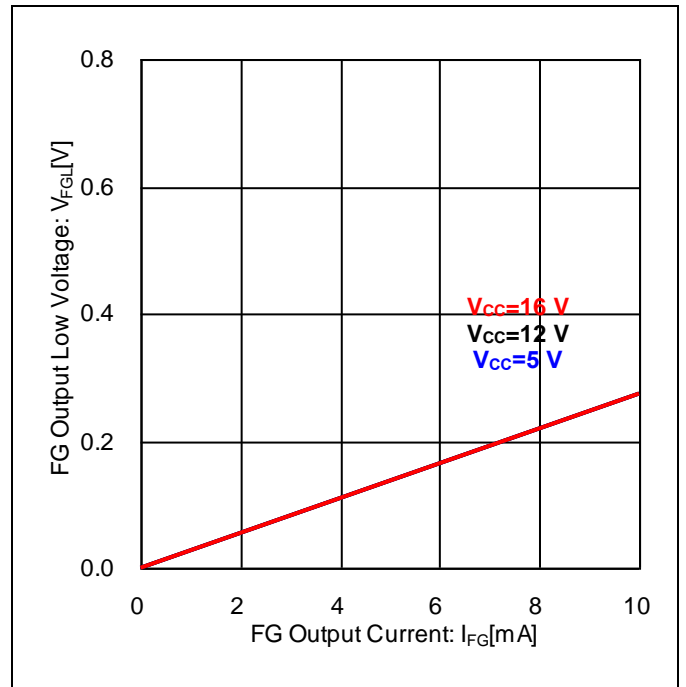

Figure 18. FG Output Low Voltage vs FG Output Current (Ta=25 °C)

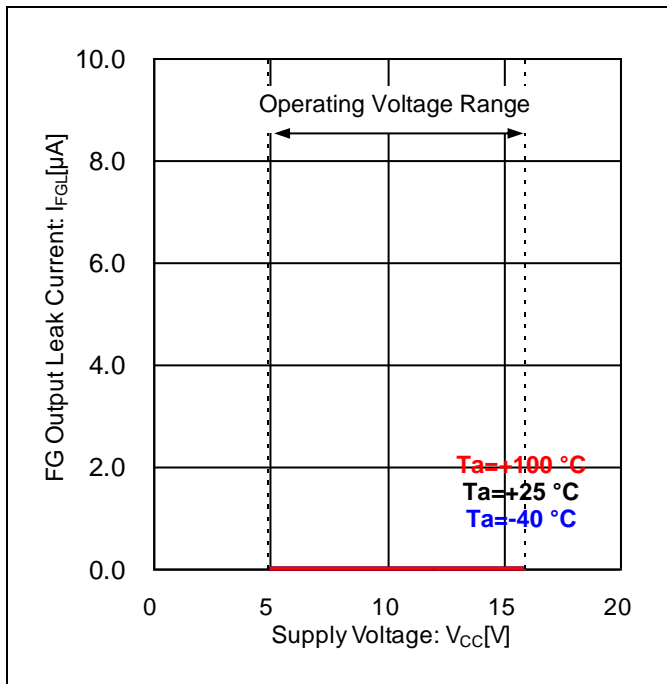

Figure 19. FG Output Leak Current vs Supply Voltage

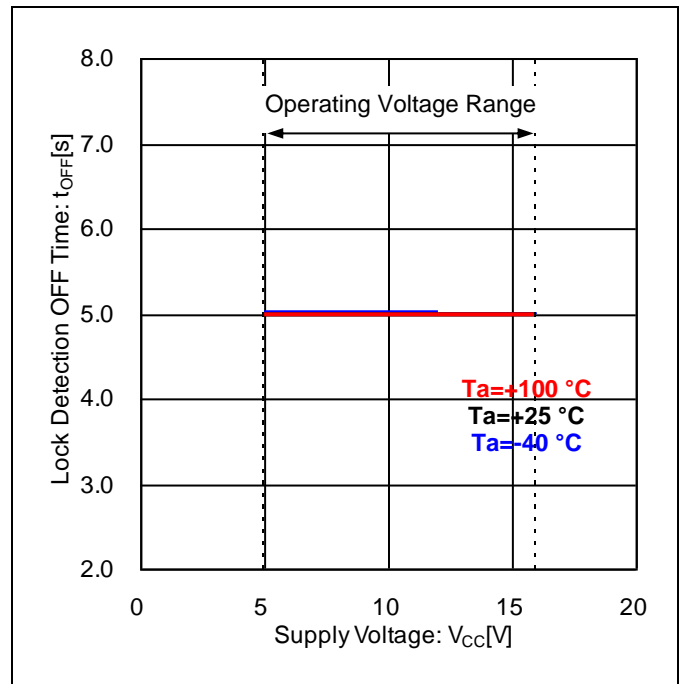

Figure 20. Lock Detection OFF Time vs Supply Voltage

Typical Performance Curves - continued
(Reference Data)

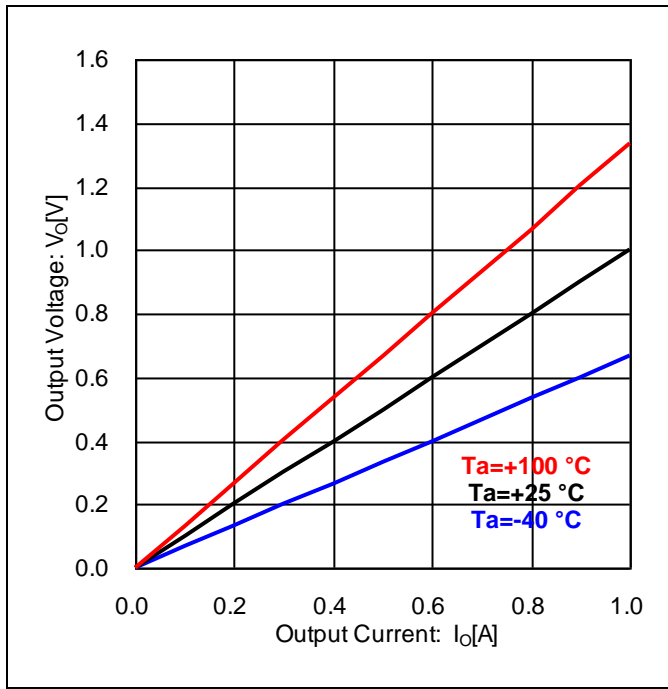

Figure 21. Output Voltage vs Output Current
(V_{CC}=12 V)

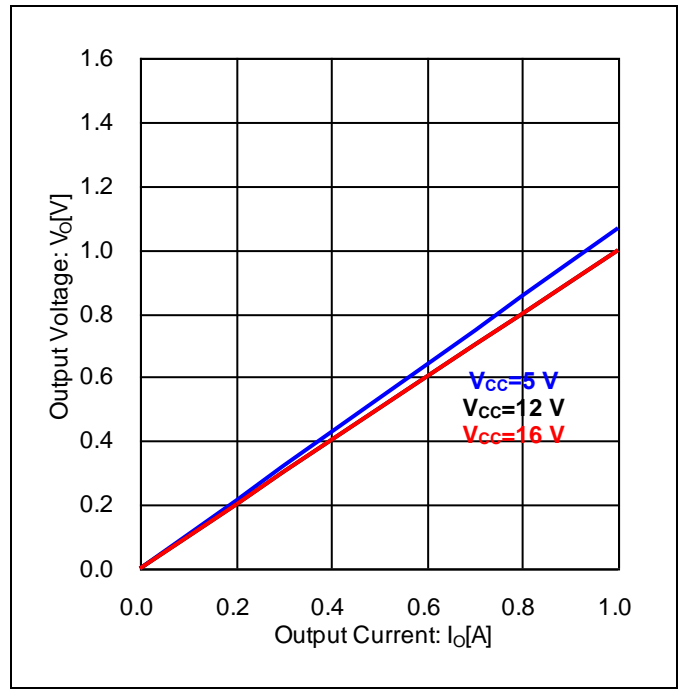

Figure 22. Output Voltage vs Output Current
(T_a=25 °C)

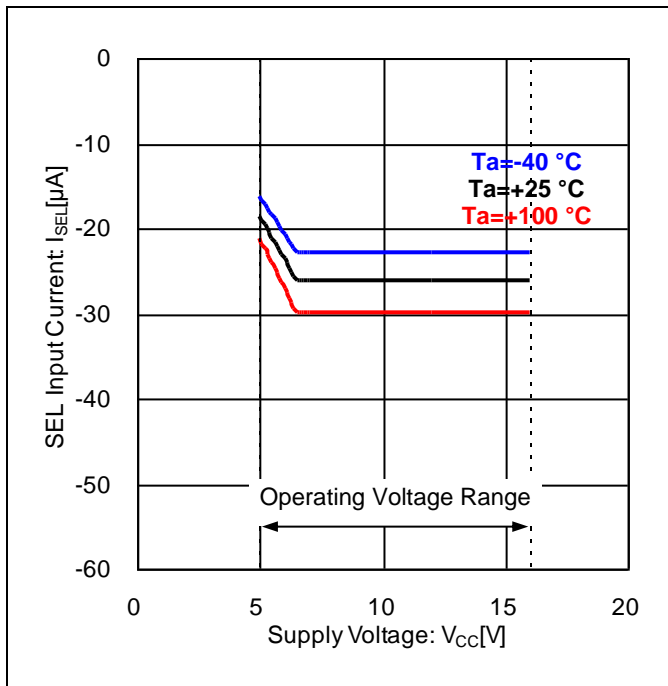

Figure 23. SEL Input Current vs Supply Voltage
(V_{SEL}=0 V)

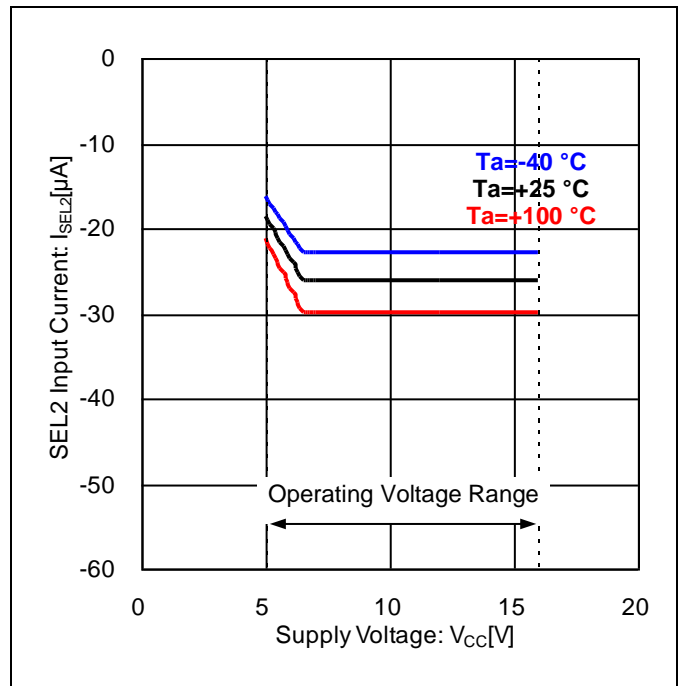

Figure 24. SEL2 Input Current vs Supply Voltage
(V_{SEL2}=0 V)

Typical Performance Curves - continued
 (Reference Data)

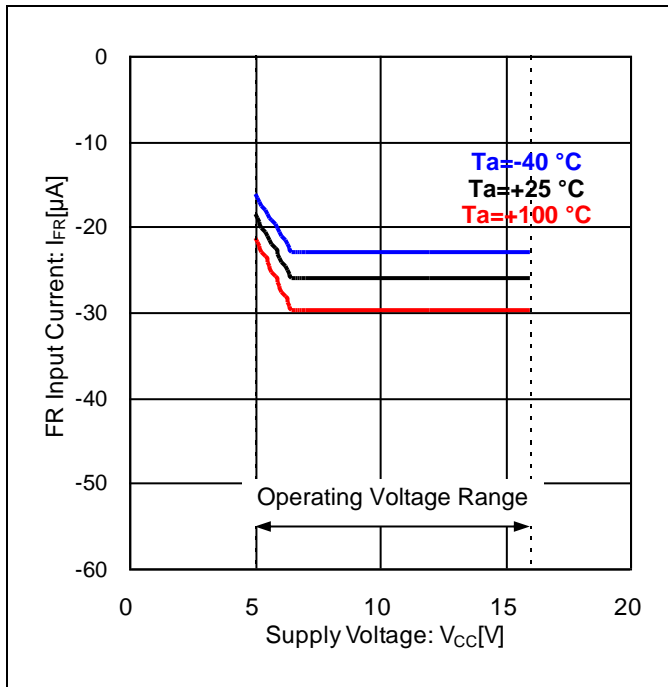

Figure 25. FR Input Current vs Supply Voltage
 ($V_{FR}=0 V$)

Description of Function Operations

1. Sensor-less Full Sine Drive

BD63242EFV is a motor driver IC for sensor-less full sine drive. It is a sensor-less drive which does not require a hall device as a position detection sensor. And, it drives the output current of a three-phase brushless DC motor with a sine waveform.

1.1. Operation at Start-up

At start-up, it confirms the rotation of the rotor in the normal rotation judgement section for 50 ms (Typ). If it detects normal rotation, the state moves to the BEMF detection driving section. If it detects reverse rotation, it sets output logic of U, V, and W to low, then stops the rotation of the rotor. After 5 s (Typ), it moves to the normal rotation judgement section again. Otherwise, it is judged that the rotor is stopped and it moves to the fixed initial position section. In the fixed initial position section, it performs the operation to fix the rotor in the initial position for a given period of time (1.15 s (Typ)). After that, it moves to the forcibly synchronized start-up section. In the forcibly synchronized start-up section, it gradually increases the frequency at which the output is switched until the 8 electrical cycles^(Note 7) and accelerates the motor. After the forcibly synchronized start-up is completed, it moves to the BEMF detection driving section.

(Note 7) One period for switching the output is defined as an electrical cycle. (Electrical Angle 360 degree)

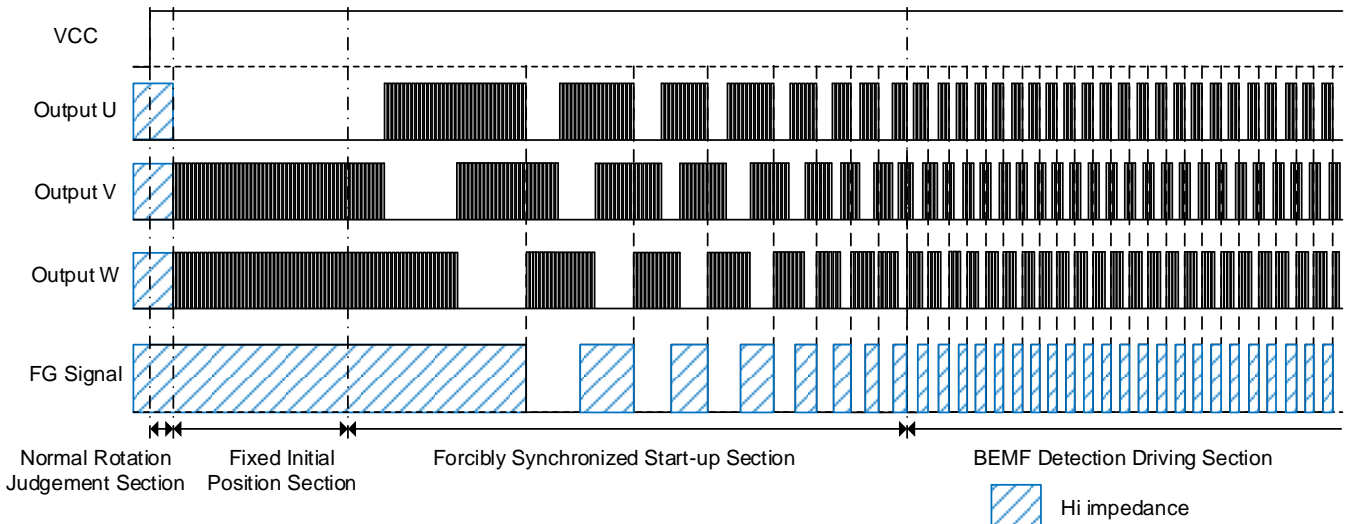

Figure 26. Timing Chart of Output Signals (U, V, W) and FG Signal

Table 1. Driving Section Description

Driving Section	Function
Normal Rotation Judgement Section	Detect the rotation of the rotor. (50 ms (Typ))
Fixed Initial Position Section	Fix the rotor in the initial position. (1.15 s (Typ))
Forcibly Synchronized Start-up Section	Gradually increases the frequency at which the output is switched until 8 electrical cycles and accelerates the motor.
BEMF Detection Driving Section	Normal driving by BEMF detection.

In the forcibly synchronized start-up section, as the number of electrical cycles increases, the output switching frequency increases. The output switching frequency depends on the SOSC frequency determined by the capacitor value which is in between the SOSC pin and the GND.

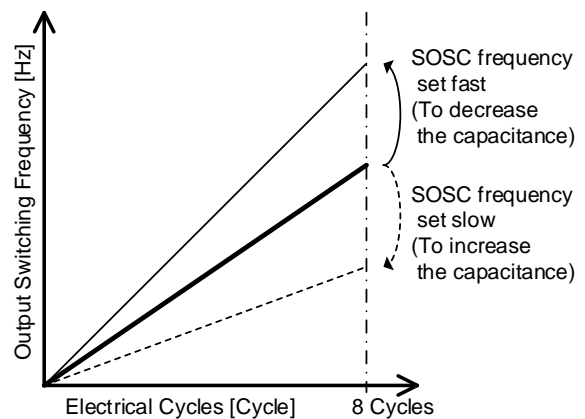

Figure 27. Output Switching Frequency vs Electrical Cycles (Forcibly Synchronized Start-up Section)

1. Sensor-less Full Sine Drive – continued

1.2. Frequency Setting in Forcibly Synchronized Start-up Section

In the forcibly synchronized start-up section, the output switching frequency depends on the SOSC frequency determined by the capacitor value which is in between the SOSC pin and the GND. The output switching frequency differs depending on various characteristic parameters of motors. It is necessary to select the appropriate capacitor value for stable start-up operation.

Set the appropriate capacitor value as follows. At first, set the capacitor value to 680 pF and confirm start-up operation. Then, confirm the upper and lower limit of the capacitor value that makes the start-up operation impossible by increasing/decreasing the capacitor value. Finally, determine the appropriate capacitor value from the upper and lower limit of the capacitor value. For the motor with a small BEMF, the capacitor value tends to be small.

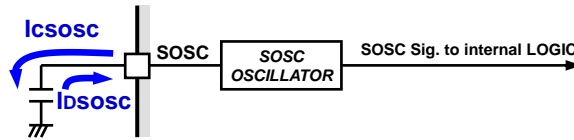

Figure 28. The SOSC Pin and IC Internal Circuit

Equation

$$f_{SOSC} = \frac{|I_{DSOSC} \times I_{CSOSC}|}{C_{SOSC} \times (|I_{DSOSC}| + |I_{CSOSC}|) \times (V_{SOSCH} - V_{SOSCL})} \text{ [Hz]}$$

Where:

- f_{SOSC} is the SOSC frequency [Hz]
- C_{SOSC} is the SOSC capacitor value [F]
- I_{DSOSC} is the SOSC discharge current [A] (Typ +44 μ A)
- I_{CSOSC} is the SOSC charge current [A] (Typ -44 μ A)
- V_{SOSCH} is the SOSC high voltage [V] (Typ 1.0 V)
- V_{SOSCL} is the SOSC low voltage [V] (Typ 0.5 V)

Example) If the SOSC capacitor value is 680 pF, the SOSC frequency is about 64.7 kHz.

$$f_{SOSC} = \frac{|44 \mu \times (-44 \mu)|}{680 \text{ p} \times (|44 \mu| + |-44 \mu|) \times (1.0 - 0.5)} \cong 64.7 \text{ [kHz]}$$

Table 2. Setting Example of SOSC frequency

Csosc [pF]	fsosc [kHz]
470	93.6
680	64.7
820	53.7

Description of Function Operations – continued

2. Current Limit

BD63242EFV has the current limit function that limits the current flowing through the motor coil. The current limit function differs depending on each driving sections.

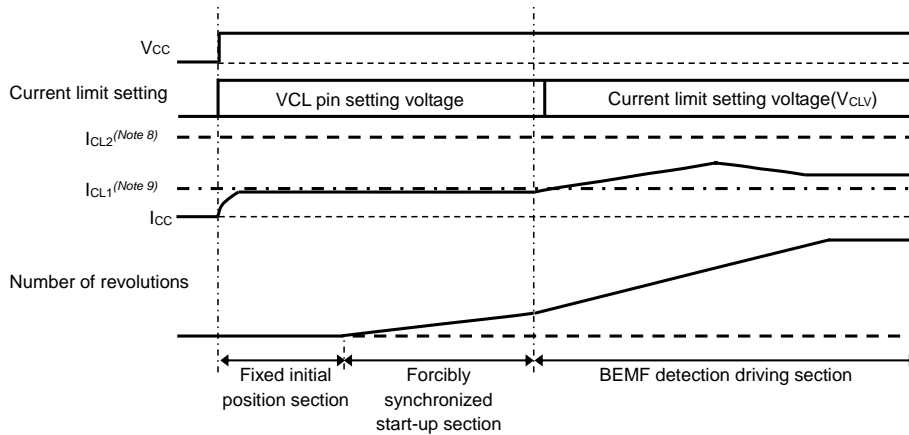

(Note 8) Current limit setting determined by current limit voltage (V_{CLV}).
 (Note 9) Current limit setting determined by the VCL pin setting voltage.

Figure 29. Timing Chart in Start-up

When not using the current limit function, short the RNF pin with GND.

2.1. Current Limit in Fixed Initial Position and Forcibly Synchronized Start-up Section

The current limit in fixed initial position and forcibly synchronized start-up section, adjusts output PWM duty when the current flowing through the motor coil detects being a set current value or more. The current limit setting value is determined by the current limit setting voltage inside the IC (V_{CL1}) (the voltage of 1/15 (Typ) of the VCL pin input voltage) and the RNF pin voltage. As shown in Figure 30, if the current detection resistance (R₁) is 0.20 Ω and the VCL pin input voltage (V_{VCL}) is 0.75 V, the current limit setting value and the maximum power consumption value of the current detection resistance can be obtained from the following formula.

$$V_{CL1} = V_{VCL} \times \frac{1}{15} = \frac{0.75}{15} = 50 \text{ [mV]}$$

$$I_{CL1} = \frac{V_{CL1}}{R_1} = \frac{50 \text{ m}}{0.2} = 0.25 \text{ [A]}$$

$$P_{RMAX} = V_{CL1} \times I_{CL1} = 50 \text{ m} \times 0.25 = 0.0125 \text{ [W]}$$

Where:
 V_{VCL} is the VCL pin input voltage [V]
 V_{CL1} is the current limit setting voltage inside the IC [V]
 R₁ is the current detection resistance [Ω]
 I_{CL1} is the current limit setting value [A]
 P_{RMAX} is the maximum power consumption value of the current detection resistance [W]

As shown in Figure 30, the IC small signal GND line should be separated from the motor large current GND line connected to R₁.

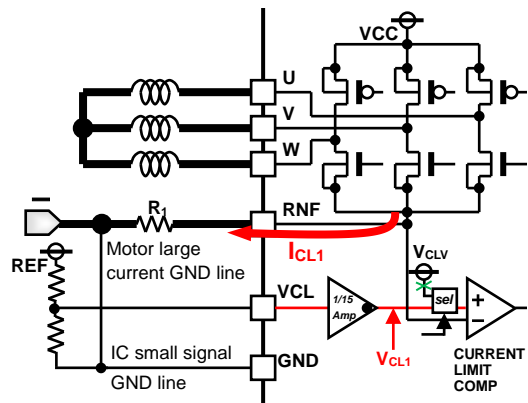

Figure 30. Current Limit Setting (Fixed Initial Position, Forcibly Synchronized Start-up Section)

2.1. Current Limit in Fixed Initial Position and Forcibly Synchronized Start-up Section – continued

The relationship between the VCL pin input voltage and the current limit setting voltage (V_{CL1}) is shown in Figure 31.

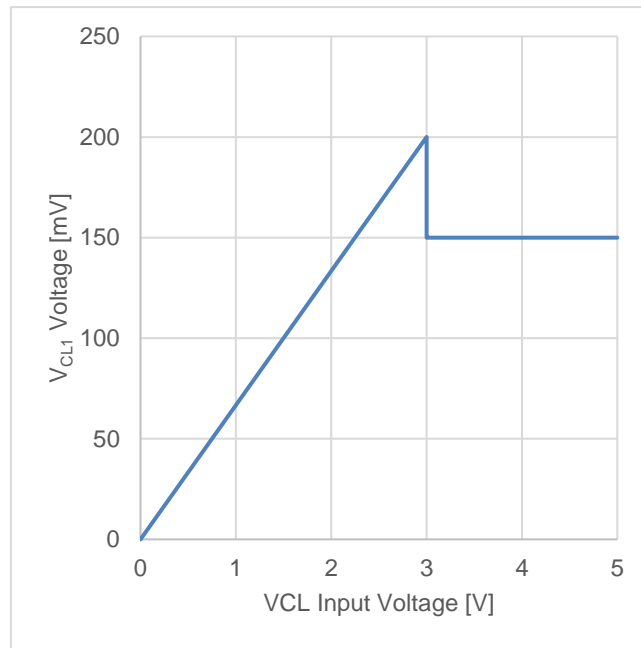

Figure 31. V_{CL1} Voltage vs VCL Input Voltage ($V_{CC}=12\text{ V}$)

If the VCL pin input voltage is 3 V, the internal setting voltage may oscillate at 150 mV and 200 mV due to the fluctuation of the input voltage. It is recommended to set the VCL pin input voltage to 0V to 2.25V or 4.5 V to the REF pin voltage.

2.2. Current Limit in BEMF Detection Driving Section

The current limit in BEMF detection driving section, turns OFF the high side output when the current flowing through the motor coil detects being a set current value or more. The current limit setting value is determined by the current limit setting voltage inside the IC (V_{CLV}) and the RNF pin voltage. As shown in Figure 32, if the current detection resistance (R_1) is 0.20 Ω , the current limit setting value and the maximum power consumption value of the current detection resistance can be obtained from the following formula.

$$I_{CL2} = \frac{V_{CLV}}{R_1} = \frac{150\text{ m}}{0.2} = 0.75\text{ [A]}$$

$$P_{RMAX} = V_{CLV} \times I_{CL2}$$

$$= 150\text{ m} \times 0.75 = 0.113\text{ [W]}$$

Where:

- V_{CLV} is the current limit setting voltage [V]
- R_1 is the current detection resistance [Ω]
- I_{CL2} is the current limit setting value [A]
- P_{RMAX} is the maximum power consumption value of the current detection resistance [W]

As shown in Figure 32, the IC small signal GND line should be separated from the motor large current GND line connected to R_1 .

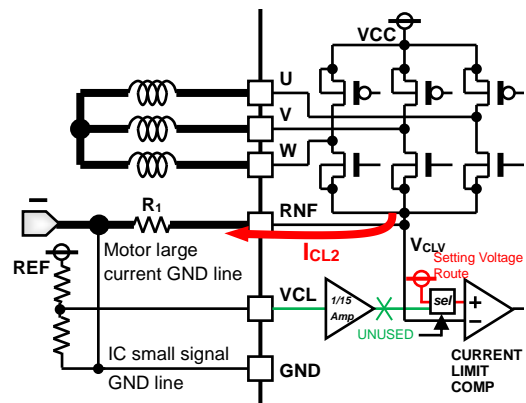

Figure 32. Current Limit Setting (BEMF Detection Driving Section)

Description of Function Operation – continued

3. Output Signals (U, V, W) and FG Signal Logic in Driving

The timing chart of the output signals (U, V, W) and the FG signal in driving is shown in Figure 33. The FG signal outputs 1 FG or 1/2 FG by the SEL2 pin input voltage.

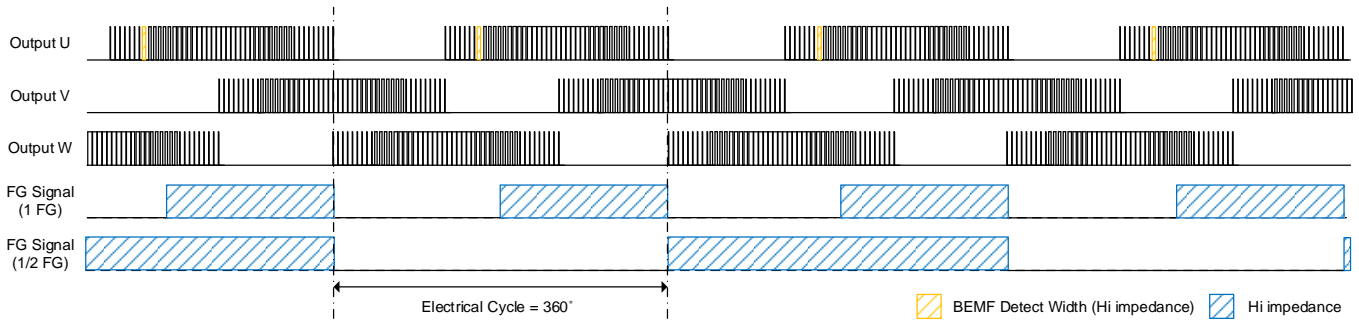

Figure 33. Timing Chart of Output Signals (U, V, W) and FG Signal in Driving

4. Start-up Assist Function (SEL Pin)

The input voltage of the SEL pin sets the start-up assist function. The input voltage range and the setting contents are shown as Table 3. If set the SEL mode 1, the start-up assist function is enabled. When the SEL mode 1 cannot detect the BEMF for a certain time (the FG output frequency is 10 Hz or less) in the BEMF detection section, it moves again to the fixed initial position section only once. After that, it moves to the forcibly synchronized start-up section. From the second time onwards, it moves to the lock protection mode ($t_{OFF}= 5.0$ s (Typ)). If set the SEL mode 2, the start-up assist function is disabled. When the SEL mode 2 cannot detect the BEMF for a certain time in the BEMF detection section, it moves to the lock protection mode. When the SEL pin is open, it sets the SEL mode 1.

Table 3. SEL Mode Voltage and Start-up Assist Function ($V_{CC}=12$ V)

SEL Mode	SEL Pin Voltage [V]	Start-up Assist Function
SEL mode 1	3.8 to V_{REF}	Enable
SEL mode 2	0.0 to 0.8	Disable

5. FG Output Pulse and Minimum BEMF Detect Width (SEL2 Pin)

The input voltage of the SEL2 pin sets the FG output pulse and the minimum BEMF detect width. The input voltage range and the setting contents are shown as Table 4. When the SEL2 pin is open, it sets the SEL2 mode 1.

Table 4. SEL2 Mode and FG Output Pulse, Minimum BEMF Detect Width ($V_{CC}=12$ V)

SEL2 Mode	SEL2 Pin Voltage [V]	FG Output Pulse for Electrical Cycles 360°	Minimum BEMF Detect Width [°]
SEL2 mode 1	3.85 to V_{REF}	FG output 1 pulse (1FG)	11.25
SEL2 mode 2	2.60 to 3.65	FG output 1 pulse (1FG)	7.5
SEL2 mode 3	1.35 to 2.40	FG output 1/2 pulse (1/2FG)	7.5
SEL2 mode 4	0.00 to 1.15	FG output 1/2 pulse (1/2FG)	11.25

Description of Function Operations – continued

6. Motor Rotation Direction Setting (FR Pin)

The FR pin input voltage sets the rotation direction of the motor. The input voltage range and function is shown as Table 5. When the FR pin is open, it sets the forward rotation mode.

Table 5. FR Mode and Motor Rotation Direction (V_{CC}=12 V)

FR Mode	FR Pin Voltage [V]	Motor Rotation Direction
Forward rotation mode	3.8 to V _{REF}	Forward rotation(U→V→W)
Reverse rotation mode	0.0 to 0.8	Reverse rotation(U→W→V)

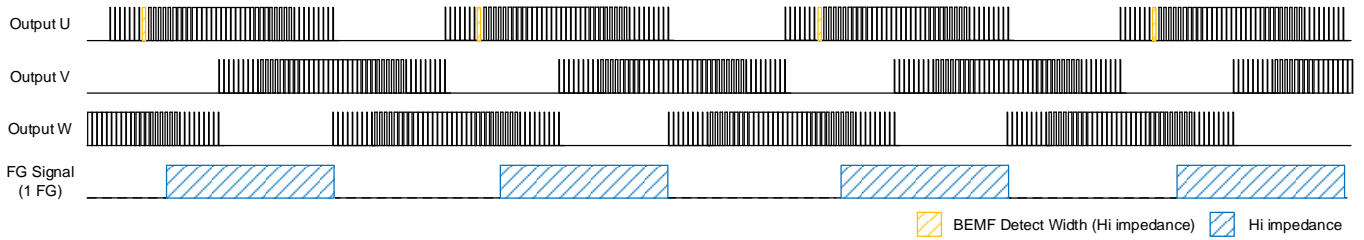

Figure 34. Timing Chart of Output Signals (U, V, W) and FG Signal in Forward Rotation Mode

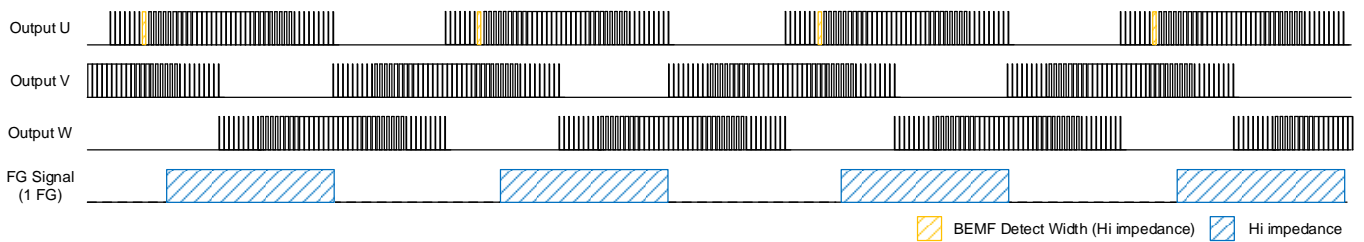

Figure 35. Timing Chart of Output Signals (U, V, W) and FG Signal in Reverse Rotation Mode

Description of Function Operations – continued

7. Speed Control

7.1. Speed Control by DC Voltage

The DC voltage input to the CONT and MIN pins control the motor rotation speed. As shown in Figure 36, the command PWM duty are generated by comparing the DC voltage input to the CONT pin with the triangular wave generated by the OSC circuit. Similarly, the minimum command PWM duty are generated by comparing the DC voltage input to the MIN pin with the triangular wave. The command PWM duty is determined by the low voltage of CONT voltage or MIN voltage.

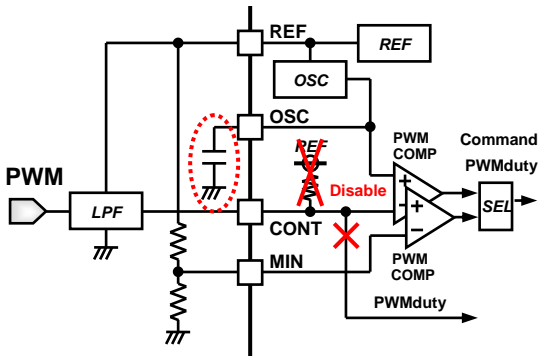

Figure 36. DC Voltage Input Application

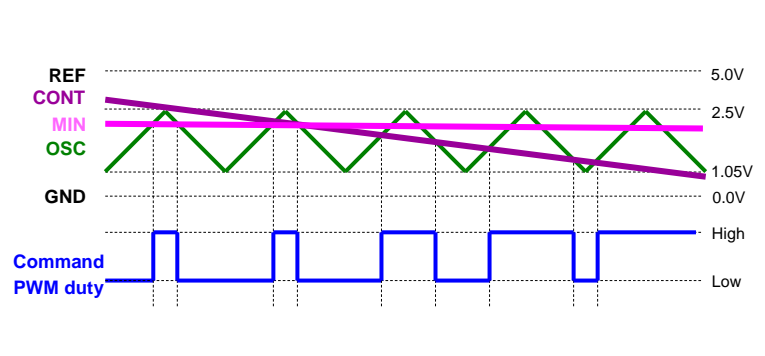

Figure 37. Timing Chart of PWM Duty Generation in DC Voltage Input

The OSC High voltage (2.50 V (Typ)) and the Low voltage (1.05 V (Typ)) are made by resistance division of the reference voltage (REF) and are designed to be resistant to voltage ratio fluctuations. Therefore, by setting the CONT pin input voltage to the REF voltage reference, it is possible to make it an application that is not easily affected even if there is voltage fluctuation of the triangular wave. In this case as well, in applications requiring strict accuracy, decide the value with sufficient margin after consideration.

7.2. OSC Frequency Setting

The capacitor value (C_{OSC}) connected to the OSC pin sets the OSC frequency.

Equation

$$f_{OSC} = \frac{|I_{DOSC} \times I_{SOSC}|}{C_{OSC} \times (|I_{DOSC}| + |I_{COSC}|) \times (V_{OSCH} - V_{OSCL})} \text{ [Hz]}$$

Where:

f_{OSC} is the OSC frequency [Hz]

C_{OSC} is the OSC capacitor value [F]

I_{DOSC} is the OSC discharge current [A] (Typ +44 μ A)

I_{COSC} is the OSC charge current [A] (Typ -44 μ A)

V_{OSCH} is the OSC high voltage [V] (Typ 2.50 V)

V_{OSCL} is the OSC low voltage [V] (Typ 1.05 V)

Example) If the OSC capacitor value is 330 pF, the OSC frequency is about 46 kHz.

$$f_{OSC} = \frac{|44 \mu \times (-44 \mu)|}{330 \text{ p} \times (|44 \mu| + |-44 \mu|) \times (2.50 - 1.05)} \cong 46.0 \text{ [kHz]}$$

7. Speed Control – continued

7.3. Speed Control by PWM Input

The PWM signal input to the CONT pin controls the motor rotation speed. As shown in Figure 38, the command PWM duty is determined by the PWM signal input to the CONT pin. The MIN pin should be pulled up the REF pin.

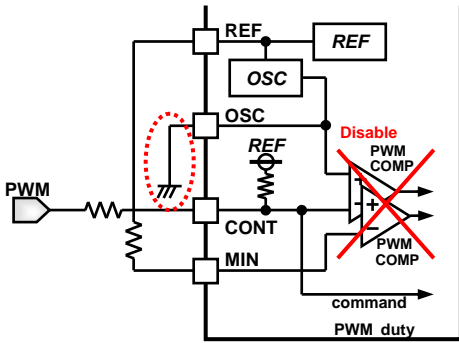

Figure 38. PWM Input Application

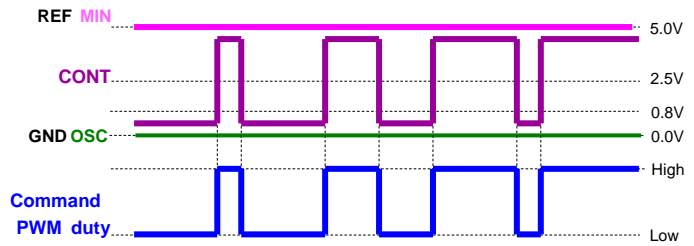

Figure 39. Timing Chart of PWM Duty Generation in PWM Input

7.4. PWM Input

When the command PWM duty reaches 5% (Typ) or more, the IC starts driving and outputs the PWM signal from output pins (U, V, W). Also, when the command PWM duty becomes 1% (Typ) or less, the IC stops driving and output pins becomes low. In other areas, the output PWM duty is proportional to the command PWM duty.

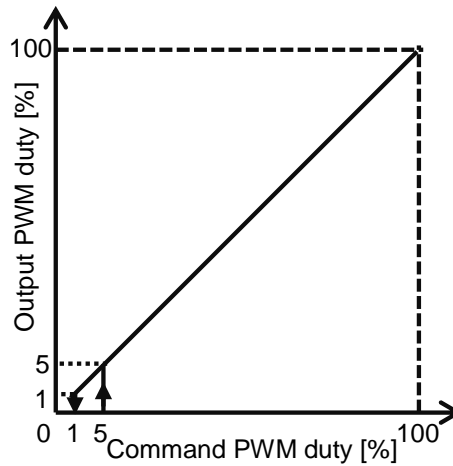

Figure 40. Output PWM Duty vs Command PWM Duty

Description of Function Operations – continued

8. Under Voltage Lock Out Protection Function (UVLO)

The under voltage lock out protection function is a protection function to prevent unexpected operation, such as large current flow, by turning output pins to OFF state in an extremely low supply voltage range deviating from normal operation. When the supply voltage is 3.9 V (Typ) or less, the under voltage lock out circuit operates (UVLO ON) and output pins are turned OFF. It returns to normal operation (UVLO OFF) when the supply voltage is 4.2 V (Typ) or more.

9. Lock Protection Function (Automatic Recovery)

When a motor is locked, the lock protection function (automatic recovery) sets output pins to low state for a certain time ($t_{OFF}=5.0$ s (Typ)) so as not to keep flowing current through the coil, and then automatically recovers. It is generated the BEMF in the coil of each phase during the motor rotation. However, when the motor lock, no the BEMF is generated. This characteristic is used to judge the motor lock state.

10. High Speed Rotation Protection Function and Low Speed Rotation Protection Function

The high speed rotation protection function and the low speed rotation protection function set output pins to low state for a certain time ($t_{OFF}=5.0$ s (Typ)) so that the motor speed does not become uncontrollable by becoming faster or slower than expected, and then automatically recovers. The speed protection function is set by the FG signal frequency condition. The FG signal frequency corresponds to the FG output pulse set with the SEL2 pin. The speed protection function and the FG frequency condition is shown as Table 6.

Table 6. Speed Protection Function and FG Signal Frequency Condition

Speed Protection Function	FG Signal Frequency Condition
High Speed Rotation Protection	400 Hz (Typ) or more
Low Speed Rotation Protection	10 Hz (Typ) or less

Thermal Resistance Model

Heat generated by consumed power of IC is radiated from the mold resin or lead frame of package. The parameter which indicates this heat dissipation capability (hardness of heat release) is called thermal resistance. Thermal resistance from the chip junction to the ambient is represented in θ_{JA} [$^{\circ}\text{C}/\text{W}$], and thermal characterization parameter from junction to the top center of the outside surface of the component package is represented in Ψ_{JT} [$^{\circ}\text{C}/\text{W}$]. Thermal resistance is divided into the package part and the substrate part. Thermal resistance in the package part depends on the composition materials such as the mold resins and the lead frames. On the other hand, thermal resistance in the substrate part depends on the substrate heat dissipation capability of the material, the size, and the copper foil area etc. Therefore, thermal resistance can be decreased by the heat radiation measures like installing a heat sink etc. in the mounting substrate. The thermal resistance model is shown in Figure 41, and equation is shown below.

Equation

$$\theta_{JA} = \frac{T_j - T_a}{P} \text{ [}^{\circ}\text{C}/\text{W}\text{]}$$

$$\Psi_{JT} = \frac{T_j - T_t}{P} \text{ [}^{\circ}\text{C}/\text{W}\text{]}$$

Where:

θ_{JA} is the thermal resistance from junction to ambient [$^{\circ}\text{C}/\text{W}$]

Ψ_{JT} is the thermal characterization parameter from junction to the top center of the outside surface of the component package [$^{\circ}\text{C}/\text{W}$]

T_j is the junction temperature [$^{\circ}\text{C}$]

T_a is the ambient temperature [$^{\circ}\text{C}$]

T_t is the package outside surface (top center) temperature [$^{\circ}\text{C}$]

P is the power consumption [W]

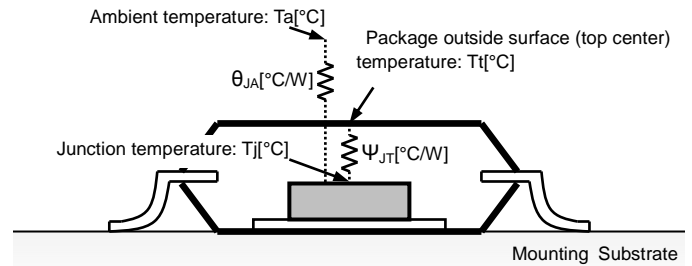
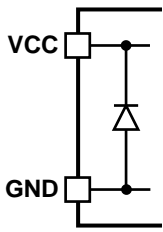

Figure 41. Thermal Resistance Model of Surface Mount

Even if it uses the same package, θ_{JA} and Ψ_{JT} are changed depending on the chip size, power consumption and the measurement environments of the ambient temperature, the mounting condition and the wind velocity, etc.

I/O Equivalence Circuits (Resistance Values are Typical)

1. VCC, GND pins



2. CONT pin

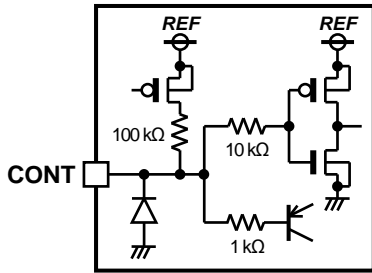

3. SEL2 pin

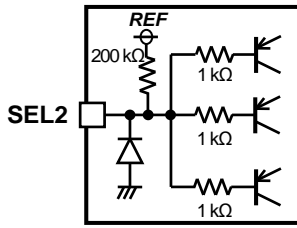

4. FR, SEL pins

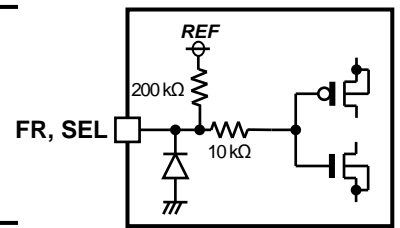

5. REF pin

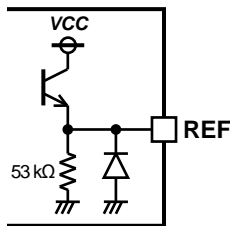

6. SOSC, OSC pins

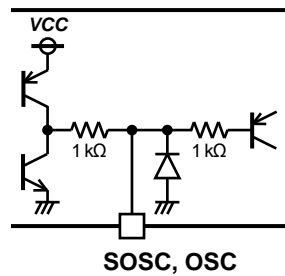

7. VCL pin

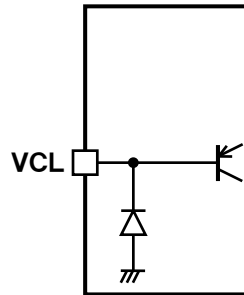

8. FG pin

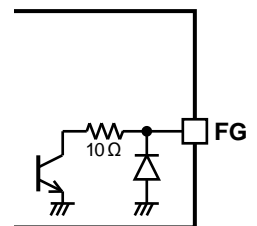

9. U, V, W, RNF pins

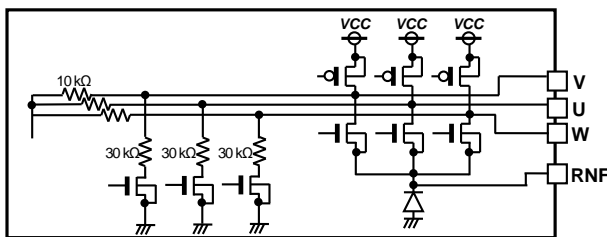

10. MIN pin

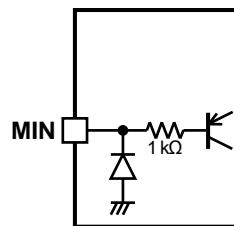

Note for Content

Timing charts might be omitted or simplified to explain functional operation.

Location of IC (Generally Three-phase Sensor-less Driver IC)

1. Generally, the three-phase sensor-less driver detects the BEMF and is rotated the motor. The line noise and resistance affect the detection of the BEMF. As shown in Figure 42, shorten the line from the motor to the IC and place the IC on the motor board.
2. For the three-phase sensor-less and the variable speed driver, it is necessary to adjust the IC and the motor for each motor unit. (Generally, the motor and the IC are adjusted by the motor manufacturer.)

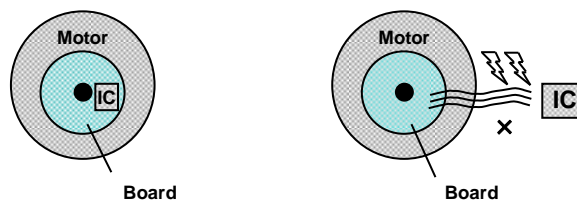

Figure 42. Location Image of IC

Operational Notes

1. Reverse Connection of Power Supply

Connecting the power supply in reverse polarity can damage the IC. Take precautions against reverse polarity when connecting the power supply, such as mounting an external diode between the power supply and the IC's power supply pins.

2. Power Supply Lines

Design the PCB layout pattern to provide low impedance supply lines. Furthermore, connect a capacitor to ground at all power supply pins. Consider the effect of temperature and aging on the capacitance value when using electrolytic capacitors.

3. Ground Voltage

Ensure that no pins are at a voltage below that of the ground pin at any time, even during transient condition. However, pins that drive inductive loads (e.g. motor driver outputs, DC-DC converter outputs) may inevitably go below ground due to back EMF or electromotive force. In such cases, the user should make sure that such voltages going below ground will not cause the IC and the system to malfunction by examining carefully all relevant factors and conditions such as motor characteristics, supply voltage, operating frequency and PCB wiring to name a few.

4. Ground Wiring Pattern

When using both small-signal and large-current ground traces, the two ground traces should be routed separately but connected to a single ground at the reference point of the application board to avoid fluctuations in the small-signal ground caused by large currents. Also ensure that the ground traces of external components do not cause variations on the ground voltage. The ground lines must be as short and thick as possible to reduce line impedance.

5. Recommended Operating Conditions

The function and operation of the IC are guaranteed within the range specified by the recommended operating conditions. The characteristic values are guaranteed only under the conditions of each item specified by the electrical characteristics.

6. Inrush Current

When power is first supplied to the IC, it is possible that the internal logic may be unstable and inrush current may flow instantaneously due to the internal powering sequence and delays, especially if the IC has more than one power supply. Therefore, give special consideration to power coupling capacitance, power wiring, width of ground wiring, and routing of connections.

7. Testing on Application Boards

When testing the IC on an application board, connecting a capacitor directly to a low-impedance output pin may subject the IC to stress. Always discharge capacitors completely after each process or step. The IC's power supply should always be turned off completely before connecting or removing it from the test setup during the inspection process. To prevent damage from static discharge, ground the IC during assembly and use similar precautions during transport and storage.

8. Inter-pin Short and Mounting Errors

Ensure that the direction and position are correct when mounting the IC on the PCB. Incorrect mounting may result in damaging the IC. Avoid nearby pins being shorted to each other specially to ground, power supply and output pin. Inter-pin shorts could be due to many reasons such as metal particles, water droplets (in very humid environment) and unintentional solder bridge deposited in between pins during assembly to name a few.

9. Unused Input Pins

Input pins of an IC are often connected to the gate of a MOS transistor. The gate has extremely high impedance and extremely low capacitance. If left unconnected, the electric field from the outside can easily charge it. The small charge acquired in this way is enough to produce a significant effect on the conduction through the transistor and cause unexpected operation of the IC. So unless otherwise specified, unused input pins should be connected to the power supply or ground line.

Operational Notes – continued

10. Regarding the Input Pin of the IC

This monolithic IC contains P+ isolation and P substrate layers between adjacent elements in order to keep them isolated. P-N junctions are formed at the intersection of the P layers with the N layers of other elements, creating a parasitic diode or transistor. For example (refer to figure below):

When $GND > Pin A$ and $GND > Pin B$, the P-N junction operates as a parasitic diode.

When $GND > Pin B$, the P-N junction operates as a parasitic transistor.

Parasitic diodes inevitably occur in the structure of the IC. The operation of parasitic diodes can result in mutual interference among circuits, operational faults, or physical damage. Therefore, conditions that cause these diodes to operate, such as applying a voltage lower than the GND voltage to an input pin (and thus to the P substrate) should be avoided.

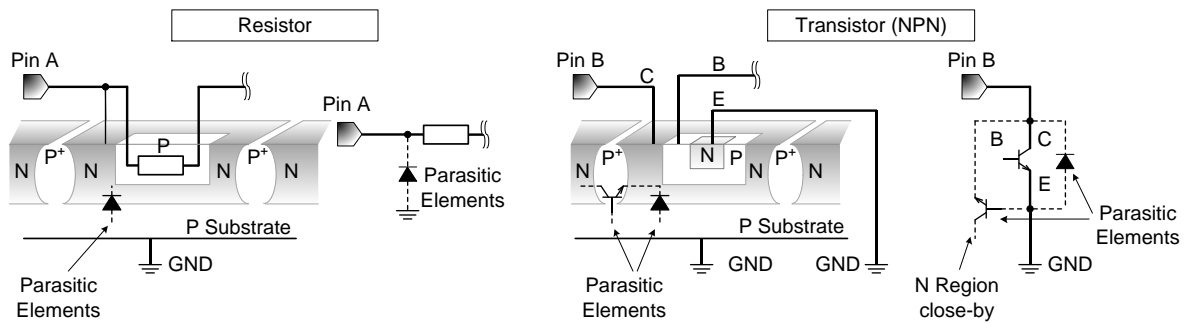

Figure 43. Example of Monolithic IC Structure

11. Ceramic Capacitor

When using a ceramic capacitor, determine a capacitance value considering the change of capacitance with temperature and the decrease in nominal capacitance due to DC bias and others.

12. Thermal Shutdown Circuit (TSD)

This IC has a built-in thermal shutdown circuit that prevents heat damage to the IC. Normal operation should always be within the IC's maximum junction temperature rating. If however the rating is exceeded for a continued period, the junction temperature (T_j) will rise which will activate the TSD circuit that will turn OFF power output pins. When the T_j falls below the TSD threshold, the circuits are automatically restored to normal operation.

Note that the TSD circuit operates in a situation that exceeds the absolute maximum ratings and therefore, under no circumstances, should the TSD circuit be used in a set design or for any purpose other than protecting the IC from heat damage.

Ordering Information

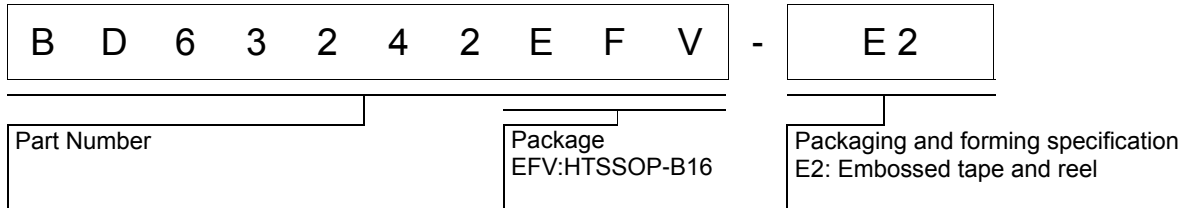

Marking Diagram

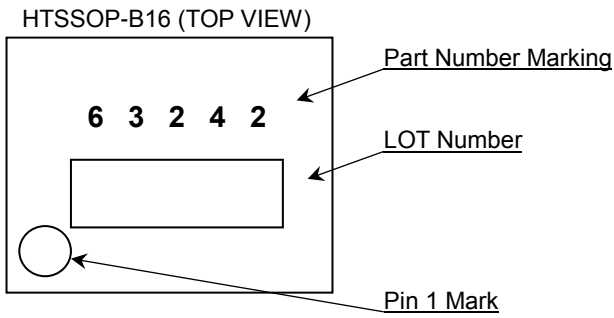

Physical Dimension and Packing Information

Package Name	HTSSOP-B16
--------------	------------

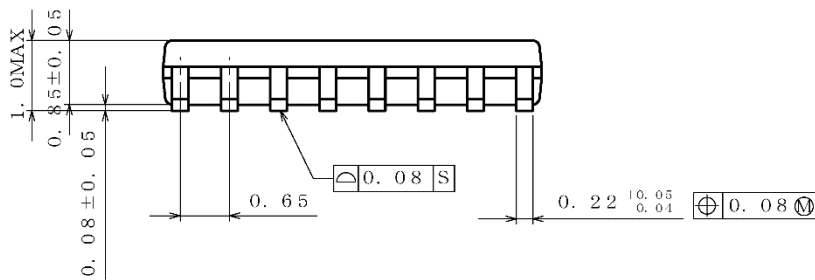
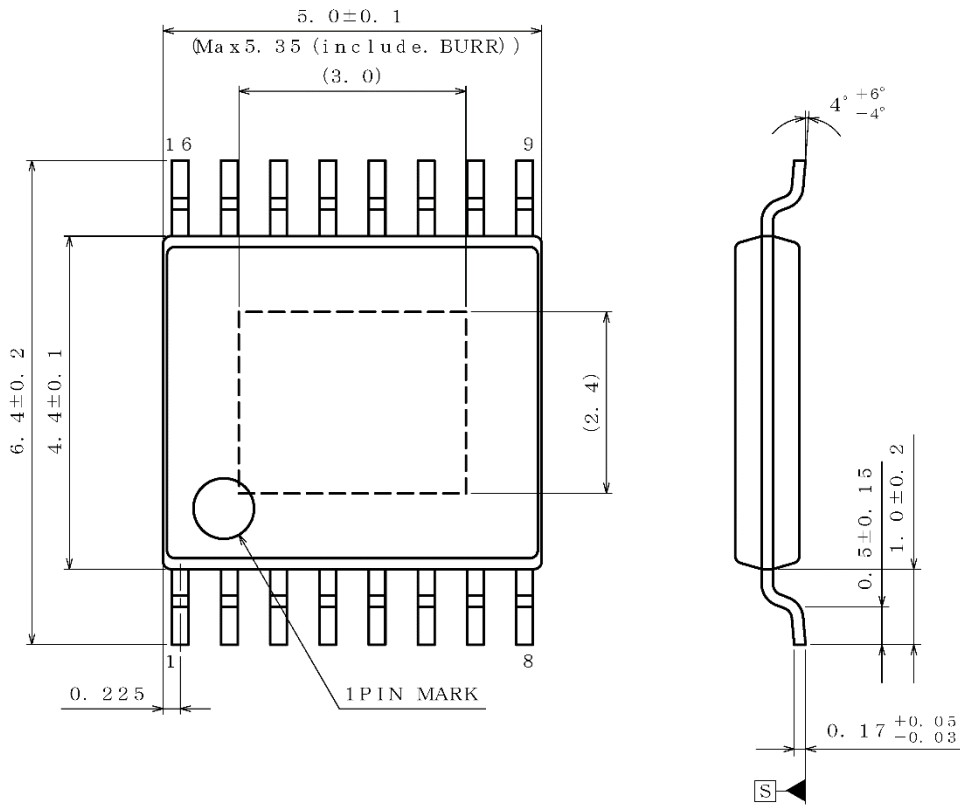

(UNIT : mm)
 PKG : HTSSOP-B16
 Drawing No. EX081-5002

< Tape and Reel Information >

Tape	Embossed carrier tape
Quantity	2500pcs
Direction of feed	E2 The direction is the pin 1 of product is at the upper left when you hold reel on the left hand and you pull out the tape on the right hand

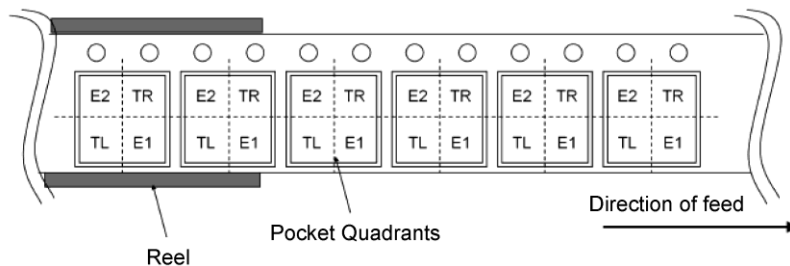

Revision History

Date	Revision	Changes
07.Aug.2018	001	New Release

Notice

Precaution on using ROHM Products

- Our Products are designed and manufactured for application in ordinary electronic equipment (such as AV equipment, OA equipment, telecommunication equipment, home electronic appliances, amusement equipment, etc.). If you intend to use our Products in devices requiring extremely high reliability (such as medical equipment ^(Note 1), transport equipment, traffic equipment, aircraft/spacecraft, nuclear power controllers, fuel controllers, car equipment including car accessories, safety devices, etc.) and whose malfunction or failure may cause loss of human life, bodily injury or serious damage to property ("Specific Applications"), please consult with the ROHM sales representative in advance. Unless otherwise agreed in writing by ROHM in advance, ROHM shall not be in any way responsible or liable for any damages, expenses or losses incurred by you or third parties arising from the use of any ROHM's Products for Specific Applications.

(Note1) Medical Equipment Classification of the Specific Applications

JAPAN	USA	EU	CHINA
CLASS III	CLASS III	CLASS II b	CLASS III
CLASS IV		CLASS III	

- ROHM designs and manufactures its Products subject to strict quality control system. However, semiconductor products can fail or malfunction at a certain rate. Please be sure to implement, at your own responsibilities, adequate safety measures including but not limited to fail-safe design against the physical injury, damage to any property, which a failure or malfunction of our Products may cause. The following are examples of safety measures:
 - Installation of protection circuits or other protective devices to improve system safety
 - Installation of redundant circuits to reduce the impact of single or multiple circuit failure
- Our Products are designed and manufactured for use under standard conditions and not under any special or extraordinary environments or conditions, as exemplified below. Accordingly, ROHM shall not be in any way responsible or liable for any damages, expenses or losses arising from the use of any ROHM's Products under any special or extraordinary environments or conditions. If you intend to use our Products under any special or extraordinary environments or conditions (as exemplified below), your independent verification and confirmation of product performance, reliability, etc. prior to use, must be necessary:
 - Use of our Products in any types of liquid, including water, oils, chemicals, and organic solvents
 - Use of our Products outdoors or in places where the Products are exposed to direct sunlight or dust
 - Use of our Products in places where the Products are exposed to sea wind or corrosive gases, including Cl₂, H₂S, NH₃, SO₂, and NO₂
 - Use of our Products in places where the Products are exposed to static electricity or electromagnetic waves
 - Use of our Products in proximity to heat-producing components, plastic cords, or other flammable items
 - Sealing or coating our Products with resin or other coating materials
 - Use of our Products without cleaning residue of flux (even if you use no-clean type fluxes, cleaning residue of flux is recommended); or Washing our Products by using water or water-soluble cleaning agents for cleaning residue after soldering
 - Use of the Products in places subject to dew condensation
- The Products are not subject to radiation-proof design.
- Please verify and confirm characteristics of the final or mounted products in using the Products.
- In particular, if a transient load (a large amount of load applied in a short period of time, such as pulse. is applied, confirmation of performance characteristics after on-board mounting is strongly recommended. Avoid applying power exceeding normal rated power; exceeding the power rating under steady-state loading condition may negatively affect product performance and reliability.
- De-rate Power Dissipation depending on ambient temperature. When used in sealed area, confirm that it is the use in the range that does not exceed the maximum junction temperature.
- Confirm that operation temperature is within the specified range described in the product specification.
- ROHM shall not be in any way responsible or liable for failure induced under deviant condition from what is defined in this document.

Precaution for Mounting / Circuit board design

- When a highly active halogenous (chlorine, bromine, etc.) flux is used, the residue of flux may negatively affect product performance and reliability.
- In principle, the reflow soldering method must be used on a surface-mount products, the flow soldering method must be used on a through hole mount products. If the flow soldering method is preferred on a surface-mount products, please consult with the ROHM representative in advance.

For details, please refer to ROHM Mounting specification

Precautions Regarding Application Examples and External Circuits

1. If change is made to the constant of an external circuit, please allow a sufficient margin considering variations of the characteristics of the Products and external components, including transient characteristics, as well as static characteristics.
2. You agree that application notes, reference designs, and associated data and information contained in this document are presented only as guidance for Products use. Therefore, in case you use such information, you are solely responsible for it and you must exercise your own independent verification and judgment in the use of such information contained in this document. ROHM shall not be in any way responsible or liable for any damages, expenses or losses incurred by you or third parties arising from the use of such information.

Precaution for Electrostatic

This Product is electrostatic sensitive product, which may be damaged due to electrostatic discharge. Please take proper caution in your manufacturing process and storage so that voltage exceeding the Products maximum rating will not be applied to Products. Please take special care under dry condition (e.g. Grounding of human body / equipment / solder iron, isolation from charged objects, setting of Ionizer, friction prevention and temperature / humidity control).

Precaution for Storage / Transportation

1. Product performance and soldered connections may deteriorate if the Products are stored in the places where:
 - [a] the Products are exposed to sea winds or corrosive gases, including Cl₂, H₂S, NH₃, SO₂, and NO₂
 - [b] the temperature or humidity exceeds those recommended by ROHM
 - [c] the Products are exposed to direct sunshine or condensation
 - [d] the Products are exposed to high Electrostatic
2. Even under ROHM recommended storage condition, solderability of products out of recommended storage time period may be degraded. It is strongly recommended to confirm solderability before using Products of which storage time is exceeding the recommended storage time period.
3. Store / transport cartons in the correct direction, which is indicated on a carton with a symbol. Otherwise bent leads may occur due to excessive stress applied when dropping of a carton.
4. Use Products within the specified time after opening a humidity barrier bag. Baking is required before using Products of which storage time is exceeding the recommended storage time period.

Precaution for Product Label

A two-dimensional barcode printed on ROHM Products label is for ROHM's internal use only.

Precaution for Disposition

When disposing Products please dispose them properly using an authorized industry waste company.

Precaution for Foreign Exchange and Foreign Trade act

Since concerned goods might be fallen under listed items of export control prescribed by Foreign exchange and Foreign trade act, please consult with ROHM in case of export.

Precaution Regarding Intellectual Property Rights

1. All information and data including but not limited to application example contained in this document is for reference only. ROHM does not warrant that foregoing information or data will not infringe any intellectual property rights or any other rights of any third party regarding such information or data.
2. ROHM shall not have any obligations where the claims, actions or demands arising from the combination of the Products with other articles such as components, circuits, systems or external equipment (including software).
3. No license, expressly or implied, is granted hereby under any intellectual property rights or other rights of ROHM or any third parties with respect to the Products or the information contained in this document. Provided, however, that ROHM will not assert its intellectual property rights or other rights against you or your customers to the extent necessary to manufacture or sell products containing the Products, subject to the terms and conditions herein.

Other Precaution

1. This document may not be reprinted or reproduced, in whole or in part, without prior written consent of ROHM.
2. The Products may not be disassembled, converted, modified, reproduced or otherwise changed without prior written consent of ROHM.
3. In no event shall you use in any way whatsoever the Products and the related technical information contained in the Products or this document for any military purposes, including but not limited to, the development of mass-destruction weapons.
4. The proper names of companies or products described in this document are trademarks or registered trademarks of ROHM, its affiliated companies or third parties.

General Precaution

1. Before you use our Products, you are requested to carefully read this document and fully understand its contents. ROHM shall not be in any way responsible or liable for failure, malfunction or accident arising from the use of any ROHM's Products against warning, caution or note contained in this document.
2. All information contained in this document is current as of the issuing date and subject to change without any prior notice. Before purchasing or using ROHM's Products, please confirm the latest information with a ROHM sales representative.
3. The information contained in this document is provided on an "as is" basis and ROHM does not warrant that all information contained in this document is accurate and/or error-free. ROHM shall not be in any way responsible or liable for any damages, expenses or losses incurred by you or third parties resulting from inaccuracy or errors of or concerning such information.

Mouser Electronics

Authorized Distributor

Click to View Pricing, Inventory, Delivery & Lifecycle Information:

[ROHM Semiconductor:](#)

[BD63242EFV-E2](#)