

9-PIN

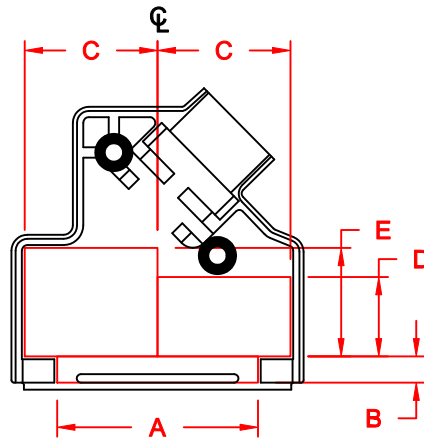

15-PIN

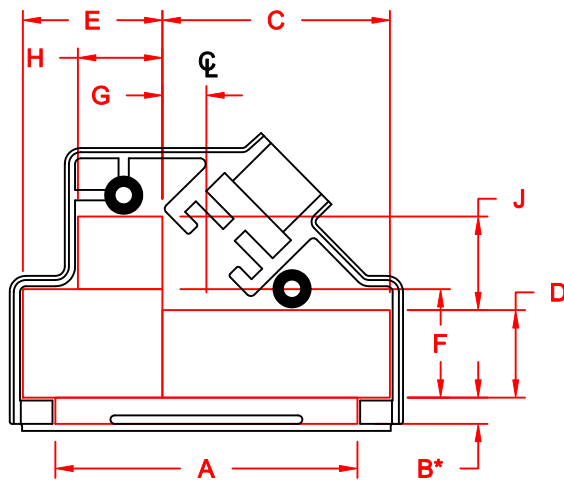

25-PIN

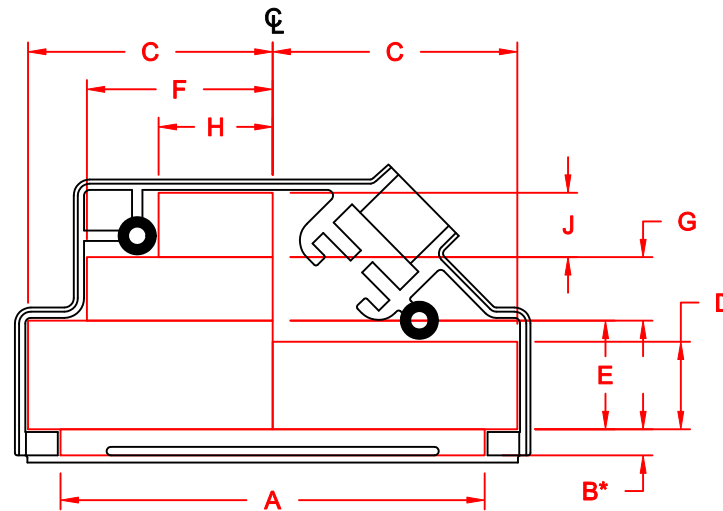

37-PIN

DIMENSIONS (mm)

	9	15	25	37
A	18.64	27.73	40.84	58.01
B*	4.03	4.21	4.21	4.21
C	13.79	18.41	30.92	33.60
D	6.14	10.76	10.87	10.92
E	14.09	14.09	18.99	14.09
F			14.09	25.12
G			5.94	9.04
H			11.43	15.41
J			9.44	8.73
PCB	10.54	10.54	10.54	10.54

SEE NOTE 1. →

SEE NOTE 2. →

NOTE:

1. "B" DIMENSION MEASURED FROM BACK SIDE OF CONNECTOR FLANGE
2. MIN. SAFE SPACING BETWEEN BACK SHELLS FOR PCB AND MOUNTED COMPONENTS
3. THESE DIMENSIONS ARE GOOD FOR THE NICKEL PLATED DIE CAST BACK SHELLS

DIE CAST

THESE DRAWINGS AND SPECIFICATIONS ARE THE PROPERTY OF MH CONNECTORS LTD. AND SHALL NOT BE REPRODUCED, COPIED OR USED AS THE BASIS FOR THE MANUFACTURE OR SALE OF APPARATUS WITHOUT WRITTEN PERMISSION.

DRAWN P. JENKINS		DATE 03-23-12
APPROVED D. CROFT		DATE 03-23-12



MH CONNECTORS LTD.

SCALE NTS	SHEET OF 1 OF 1	REV: A
DRAWING No MHDVSL INTERNAL		