

DO NOT SCALE

DIMENSIONS IN MM.

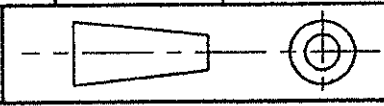

C.A.D. FILE CODE
5. C342062.2

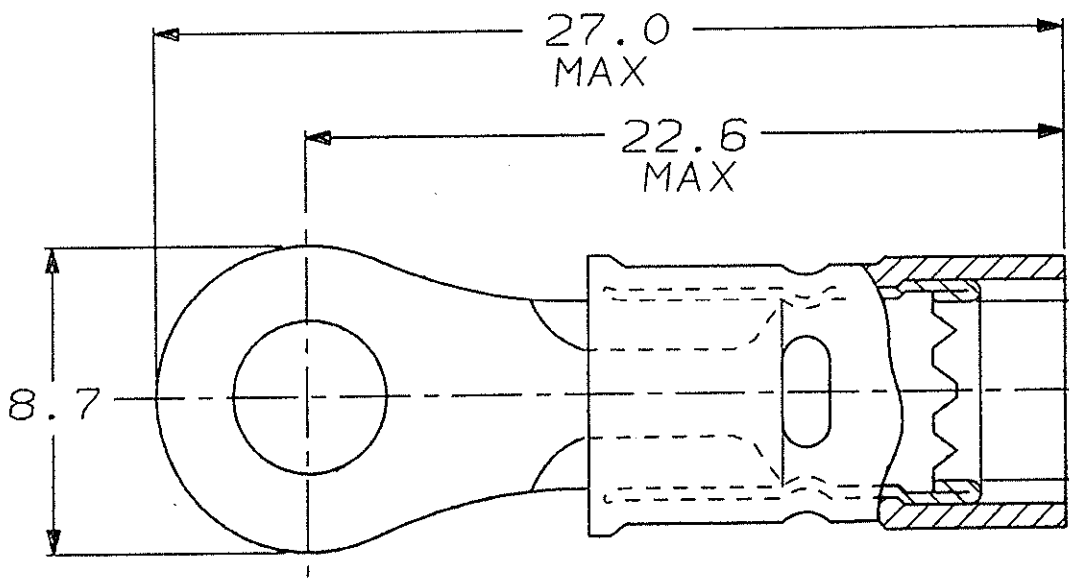

- 1. WIRE INSUL DIA 3.81-6.35
- 2. TONGUE MAT'L THICKNESS 1.07 MAX

B

A

CUSTOMER DWG FOR REFERENCE ONLY				THIS INFORMATION IS CONFIDENTIAL AND IS DISCLOSED TO YOU ON CONDITION THAT NO FURTHER DISCLOSURE IS MADE BY YOU TO OTHER THAN AMP PERSONNEL WITHOUT WRITTEN AUTHORIZATION FROM AMP OF GREAT BRITAIN LTD.									
-	-	-	-	TOLERANCES UNLESS OTHERWISE STATED :				DR. C. NIKER 17/01/95					
-	-	-	-	DEC ± 0.5				CH. B. WILSON		APP. B. WILSON			
-	-	-	-	ANGLES ± 1°				 TERMINAL HOUSE STANMORE MIDOX.					
-	-	-	-	NAME 16-14 HD PIDG R/T 5mm STUD									
A	def/m	063A-0002 04	3/04	SCALE	LOC	SIZE	DWG.No.	REV	SHEET				
2	B. WILSON	EB00-0014-95	17/01/95	NTS	E	A 4	C342062	A	1/1				
REV	APPROVED	CHANGE No.	DATE										