

Driver LC 50/60W 1200/700/1400mA fixC C SNC

essence series

Product description

- Fixed output built-in LED Driver
- Constant current LED Driver
- For luminaires of protection class I and protection class II
- Temperature protection as per EN 61347-2-13 C5e
- KC certificate for LC 60W 1400mA fixC C SNC
- Output current 1,200, 700 or 1,400 mA
- Max. output power 50 or 60 W
- Nominal life-time up to 50,000 h
- 5-year guarantee

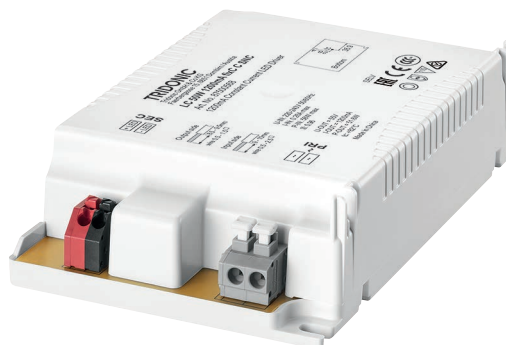

Housing properties

- Casing: polycarbonat, white
- Type of protection IP20

Functions

- Overtemperature protection
- Overload protection
- Short-circuit protection
- No-load protection



Standards, page 3

Wiring diagrams and installation examples, page 4



IP20 SELV

Driver LC 50/60W 1200/700/1400mA fixC C SNC essence series

Technical data

Rated supply voltage	220 – 240 V
AC voltage range	198 – 264 V
Mains frequency	50 / 60 Hz
Overvoltage protection	320 V AC, 1 h
THD (at 230 V, 50 Hz, full load)	< 20 %
Output current tolerance [®]	± 7.5 %
Typ. current ripple (at 230 V, 50 Hz, full load)	± 30 %
Starting time (at 230 V, 50 Hz, full load)	≤ 0.5 s
Turn off time (at 230 V, 50 Hz, full load)	≤ 0.2 s
Hold on time at power failure (output)	0 s
Ambient temperature t_a	-20 ... +50 °C
Ambient temperature t_a (at life-time 50,000 h)	40 °C
Storage temperature t_s	-40 ... +80 °C
Life-time	up to 50,000 h
Dimensions L x W x H	123 x 75 x 29.7 mm

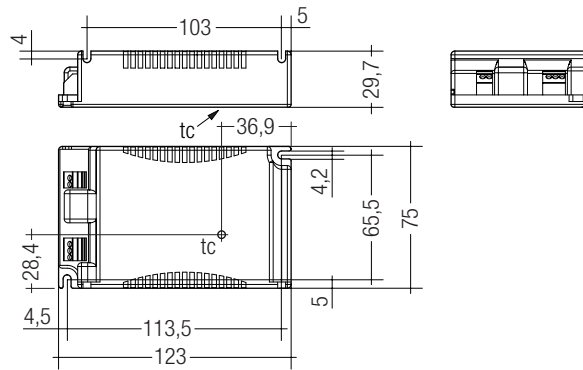

Ordering data

Type [®]	Article number [®]	Packaging, carton	Packaging, low volume	Packaging, high volume	Weight per pc.
LC 50W 1200mA fixC C SNC	87500568	30 pc(s).	450 pc(s).	2,250 pc(s).	0.151 kg
LC 60W 700mA fixC C SNC	87500569	30 pc(s).	450 pc(s).	2,250 pc(s).	0.147 kg
LC 60W 1400mA fixC C SNC	87500570	30 pc(s).	450 pc(s).	2,250 pc(s).	0.156 kg

Specific technical data

Type	Output current [®]	Input current (at 230 V, 50 Hz, full load)	Max. input power	Typ. power consumption (at 230 V, 50 Hz, full load)	Output power range	λ at full load [®]	Efficiency at full load [®]	λ at min. load [®]	Efficiency at min. load [®]	Min. forward voltage	Max. forward voltage	Max. output voltage	Max. output peak current at full load [®]	Max. output peak current at min. load [®]	Max. casing temperature t_c
LC 50W 1200mA fixC C SNC	1,200 mA	260 mA	58 W	55.5 W	36.0 – 51.6 W	0.96	90 %	0.92C	88 %	30 V	43 V	55 V	1,700 mA	1,800 mA	82 °C
LC 60W 700mA fixC C SNC	700 mA	290 mA	68 W	66.0 W	42.0 – 59.5 W	0.96	91 %	0.94C	89 %	60 V	85 V	100 V	1,000 mA	1,100 mA	85 °C
LC 60W 1400mA fixC C SNC	1,400 mA	300 mA	68 W	66.5 W	42.0 – 60.2 W	0.96	90 %	0.94C	88 %	30 V	43 V	55 V	2,000 mA	2,100 mA	88 °C

[®] Test result at 230 V, 50 Hz.

[®] The trend between min. and full load is linear.

[®] Output current is mean value.

[®] KC approval mark for art. no.: 87500568 and 87500570.

Standards

EN 55015
EN 61000-3-2
EN 61000-3-3
EN 61347-1
EN 61347-2-13
EN 61547

Overload protection

If the output voltage range is exceeded the LED Driver will protect itself and LED may flicker. After elimination of the overload, the nominal operation is restored automatically.

Overtemperature protection

The LED Driver is protected against temporary thermal overheating. If the temperature limit is exceeded, the output current is reduced to limit t_c at a certain level.

The temperature protection is activated typically at 10 °C above t_c max.

Short-circuit behaviour

In case of a short circuit on the secondary side (LED) the LED Driver switches into hic-cup mode. After elimination of the short-circuit fault the LED Driver will recover automatically.

No-load operation

The LED Driver works in burst working mode to provide a constant output voltage regulation which allows the application to be able to work safely when LED string opens due to a failure.

Expected life-time

Type	t_a	40 °C	50 °C	60 °C
LC 50W 1200mA fixC C SNC	t_c	70 °C	82 °C	x
	Life-time	50,000 h	30,000 h	x
LC 60W 700mA fixC C SNC	t_c	75 °C	85 °C	x
	Life-time	50,000 h	30,000 h	x
LC 60W 1400mA fixC C SNC	t_c	75 °C	88 °C	x
	Life-time	50,000 h	30,000 h	x

The LED Drivers are designed for a life-time stated above under reference conditions and with a failure probability of less than 10 %.

Life-time declarations are informative and represent no warranty claim.

Glow-wire test

according to EN 61347-1 with increased temperature of 850 °C passed.

Mounting of device

Max. torque for fixing: 0.5 Nm/M4

Conditions of use and storage

Humidity: 5% up to max. 85 %, not condensed (max. 56 days/year at 85 %)

Storage temperature: -40 °C up to max. +80 °C

The devices have to be within the specified temperature range (t_a) before they can be operated.

Installation instructions

The LED module and all contact points within the wiring must be sufficiently insulated against 3 kV surge voltage.

Air and creepage distance must be maintained.

Replace LED module

1. Mains off
2. Remove LED module
3. Wait for 10 seconds
4. Connect LED module again

Hot plug-in or secondary switching of LEDs is not permitted and may cause a very high current to the LEDs.

Maximum loading of automatic circuit breakers in relation to inrush current

Automatic circuit breaker type	C10	C13	C16	C20	B10	B13	B16	B20	Inrush current	
Installation \emptyset	1.5 mm ²	1.5 mm ²	1.5 mm ²	2.5 mm ²	1.5 mm ²	1.5 mm ²	1.5 mm ²	2.5 mm ²	I_{max}	Time
LC 50W 1200mA fixC C SNC	35	45	60	80	35	45	60	80	10 A	50 μ s
LC 60W 700mA fixC C SNC	25	35	45	55	25	35	45	55	12 A	50 μ s
LC 60W 1400mA fixC C SNC	25	35	45	55	25	35	45	55	12 A	50 μ s

These are max. values calculated out of continuous current running the device on full load.

There is no limitation due to inrush current.

If load is smaller than full load for calculation only continuous current has to be considered.

Harmonic distortion in the mains supply (at 230 V / 50 Hz and full load) in %

	THD	3.	5.	7.	9.	11.
LC 50W 1200mA fixC C SNC	< 20	< 12	< 4	< 2	< 2	< 2
LC 60W 700mA fixC C SNC	< 20	< 12	< 4	< 2	< 2	< 2
LC 60W 1400mA fixC C SNC	< 20	< 12	< 4	< 2	< 2	< 2

Wiring diagram

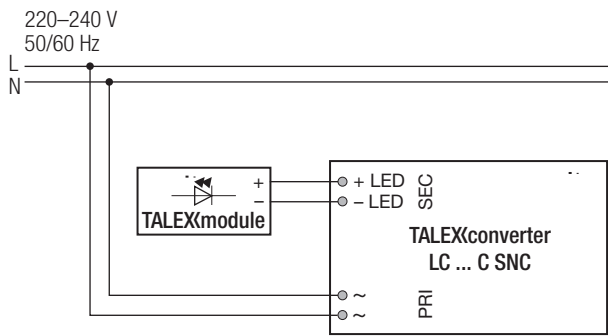

Insulation and electric strength testing of luminaires

Electronic devices can be damaged by high voltage. This has to be considered during the routine testing of the luminaires in production.

According to IEC 60598-1 Annex Q (informative only!) or ENEC 303-Annex A, each luminaire should be submitted to an insulation test with 500 V_{DC} for 1 second. This test voltage should be connected between the interconnected phase and neutral terminals and the earth terminal. The insulation resistance must be at least 2 MΩ.

As an alternative, IEC 60598-1 Annex Q describes a test of the electrical strength with 1500 V_{AC} (or 1.414 x 1500 V_{DC}). To avoid damage to the electronic devices this test must not be conducted.

Maximum number of switching cycles

All LED Driver are tested with 50,000 switching cycles. The actually achieved number of switching cycles is significantly higher.

Additional information

Additional technical information at www.tridonic.com → Technical Data

Guarantee conditions at www.tridonic.com → Services

Life-time declarations are informative and represent no warranty claim. No warranty if device was opened.

Wiring type and cross section

The input wiring can be stranded wires with ferrules with a cross section of 0.5 – 1.5 mm² or with solid wires with a cross section of 0.5 – 2.5 mm². Strip 9 – 10 mm of insulation from the cables to ensure perfect operation of the push-wire terminals.

The output wiring can be done with a cross section of 0.5 – 1.5 mm². Strip 8.5 – 9.5 mm of insulation from the cables to ensure perfect operation of the push-wire terminals.

Input wiring

wire preparation:
Solid: 0.5 – 2.5 mm²
Fine-stranded: 0.5 – 1.5 mm²

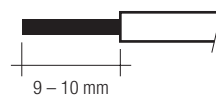

Output wiring

wire preparation:
0.5 – 1.5 mm²

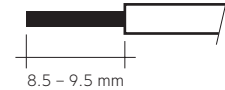

Wiring guidelines

- All connections must be kept as short as possible to ensure good EMI behaviour.
- Mains leads should be kept apart from LED Driver and other leads (ideally 5 – 10 cm distance)
- Max. length of output wires is 2 m.
- Secondary switching is not permitted.
- Incorrect wiring can damage LED modules.
- To avoid the damage of the Driver, the wiring must be protected against short circuits to earth (sharp edged metal parts, metal cable clips, louver, etc.).

Release of the wiring

Press down the "push button" and remove the cable from front.

Input terminal

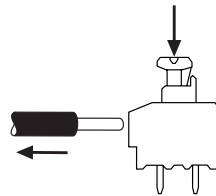

Output terminal

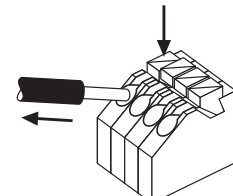

Diagrams LC 50W 1200mA fixC C SNC

Efficiency vs load

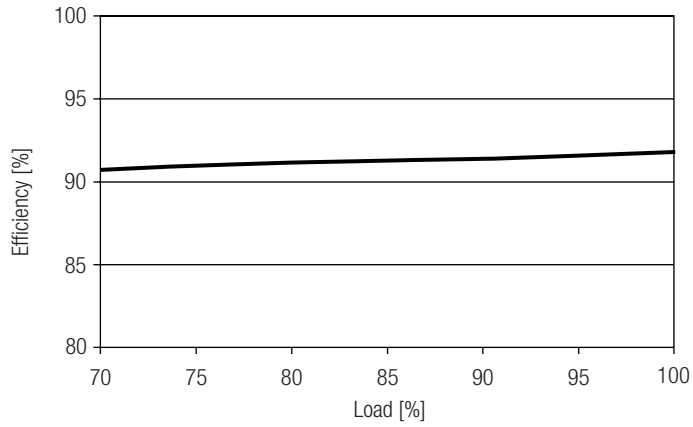

Power factor vs load

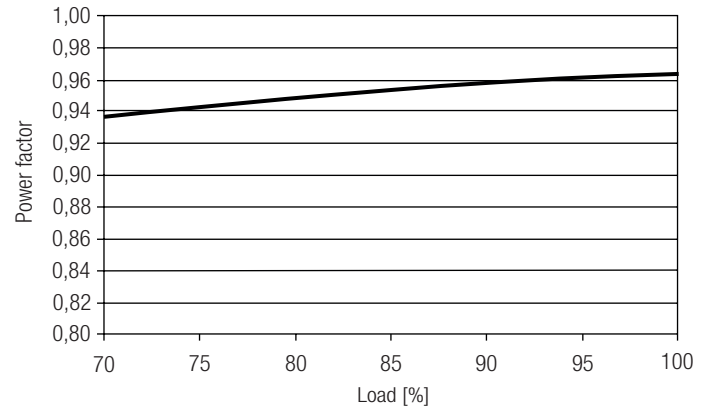

Input power vs load

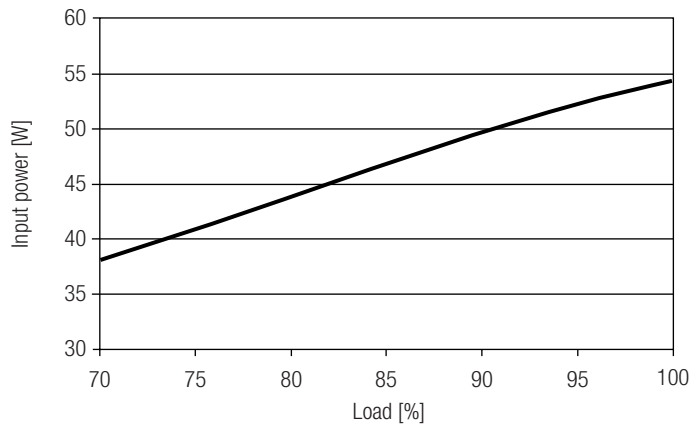

Input current vs load

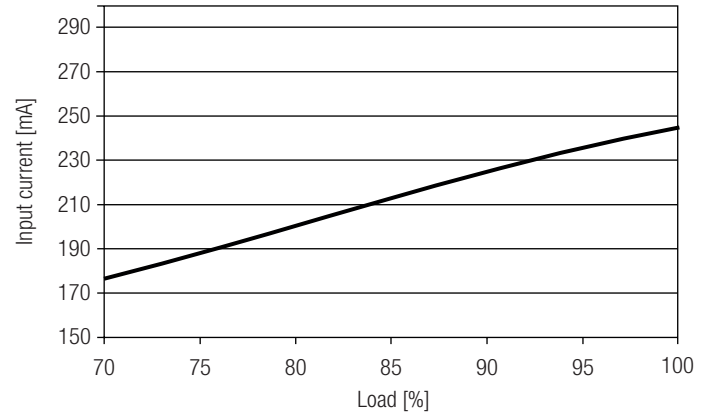

THD vs load

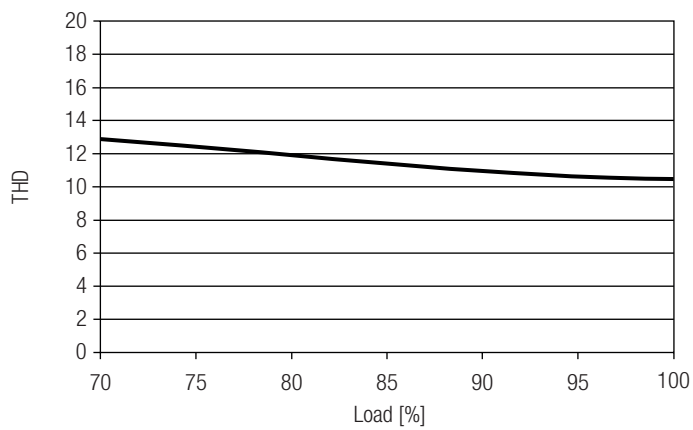

Diagrams LC 60W 700mA fixC C SNC

Efficiency vs load

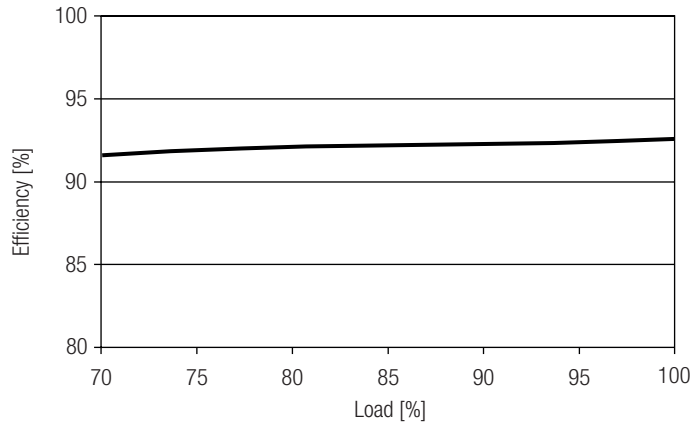

Power factor vs load

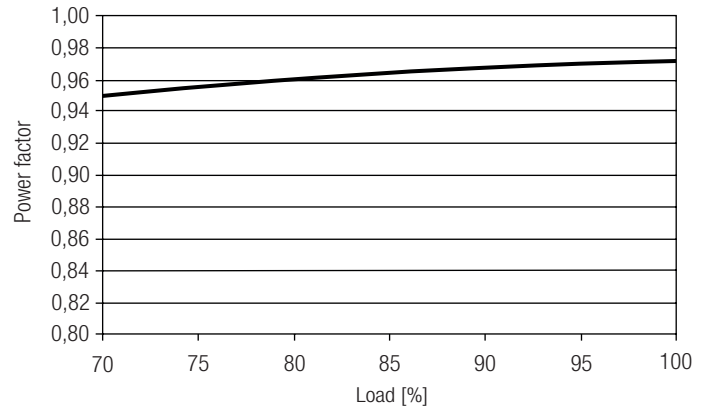

Input power vs load

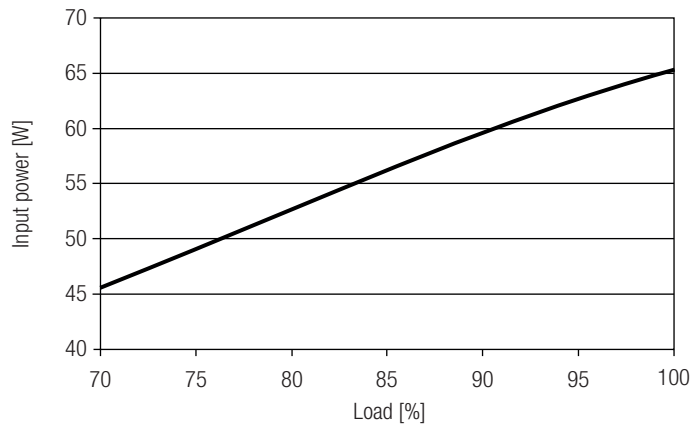

Input current vs load

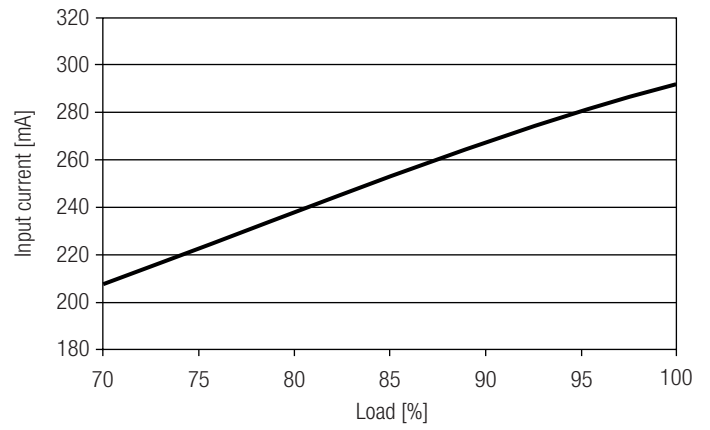

THD vs load

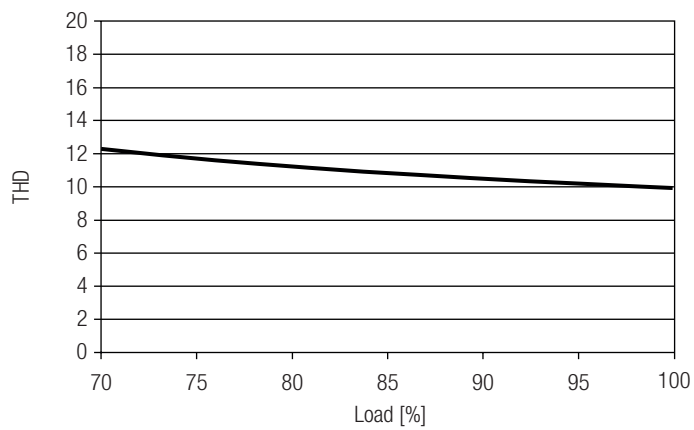

Diagrams LC 60W 1400mA fixC C SNC

Efficiency vs load

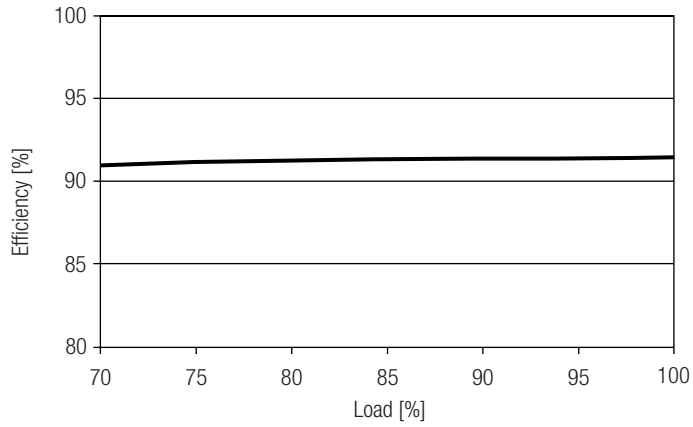

Power factor vs load

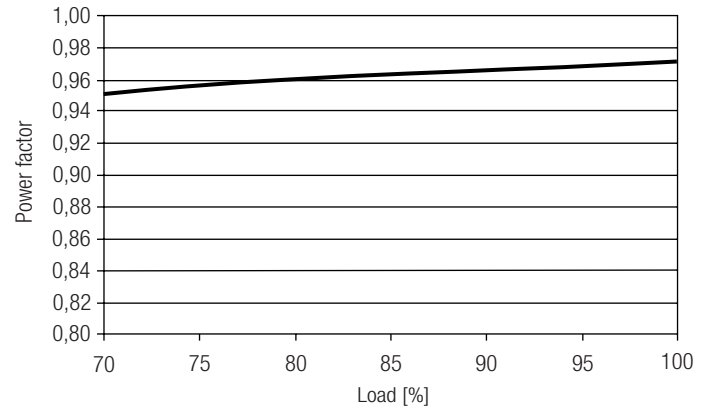

Input power vs load

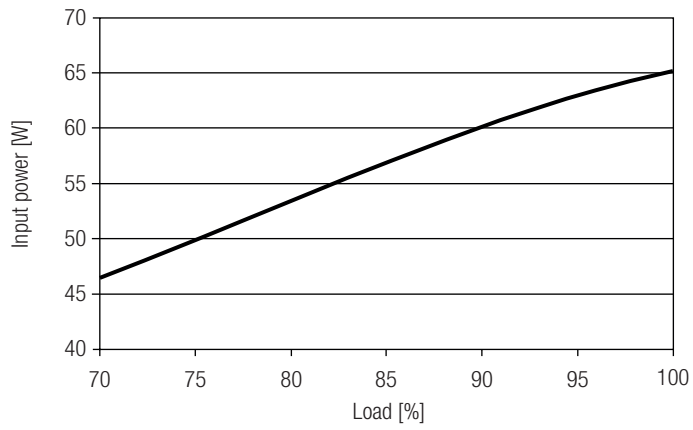

Input current vs load

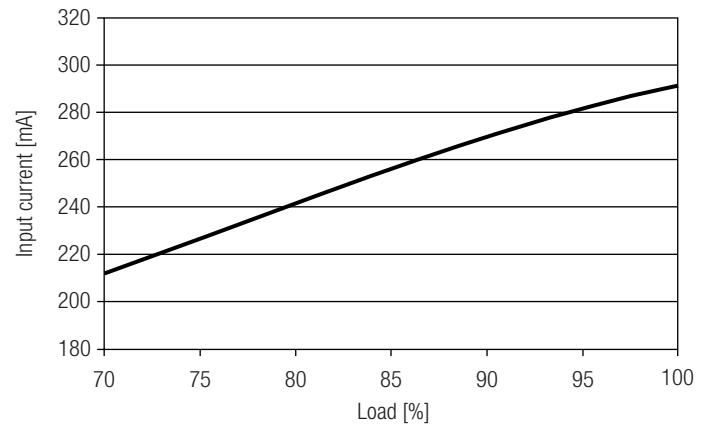

THD vs load

