

# SY 35 FM

Compliance with standard

ISO

Housing material

Cast iron

Sealing solution

Standard seals

## Dimensions

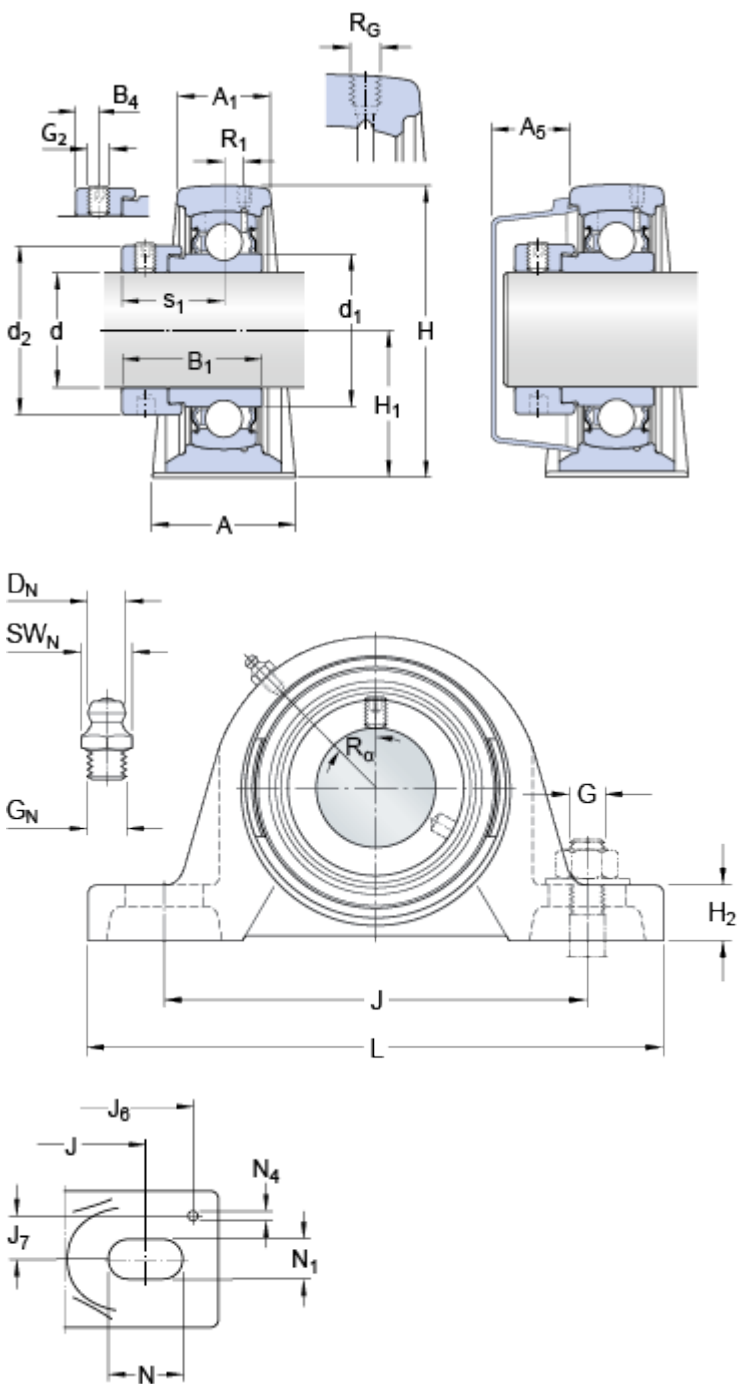

d	35	mm
d <sub>1</sub>	≈ 46.1	mm
d <sub>2</sub>	51.1	mm
A	45	mm
A <sub>1</sub>	27	mm
A <sub>5</sub>	24.5	mm
B <sub>1</sub>	38.9	mm
B <sub>4</sub>	6.75	mm
H	93	mm
H <sub>1</sub>	47.6	mm
H <sub>2</sub>	19	mm
J	126	mm
J	max. 133	mm
J	min. 119	mm
L	160	mm
N	21	mm
N <sub>1</sub>	14	mm
s <sub>1</sub>	29.4	mm

### Threaded hole

R <sub>G</sub>	1/4-28 UNF	
R <sub>1</sub>	3	mm
R <sub>α</sub>	45	°

### Grease fitting

D <sub>N</sub>	6.5	mm
SW <sub>N</sub>	7	mm

$G_N$  1/4-28 SAE-LT

### Dowel pins

$J_6$  146 mm

$J_7$  15.5 mm

$N_4$  4 mm

### Calculation data

Basic dynamic load rating  $C$  25.5 kN

Basic static load rating  $C_0$  15.3 kN

Fatigue load limit  $P_u$  0.655 kN

Limiting speed 5300 r/min

with shaft tolerance h6

### Mass

Mass bearing unit 1.5 kg

### Mounting information

Thread grub screw  $G_2$  M10x1

Hexagonal key size for grub screw  $N$  5 mm

Recommended tightening torque for grub screw 16.5 N·m

Recommended diameter for attachment bolts, mm  $G$  12 mm

Recommended diameter for attachment bolts, inch  $G$  0.5 in

### Included products

Housing SY 507 M

Bearing YET 207

### Associated products

End cover ECY 207