

Vane Type Rotary Actuator
Series CRB2/CRBU2/CRB1



Vane Type

Rotation: 90°, 180°, 270°

All series can rotate up to 270°.

The use of specially designed seals and stoppers now enables our compact vane type rotary actuators to rotate up to 270° (single vane type).

Direct mounting

The body of rotary actuator can be mounted directly.
* Direct mounting is possible for size 10 to 30 rotary actuators with angle adjuster only.

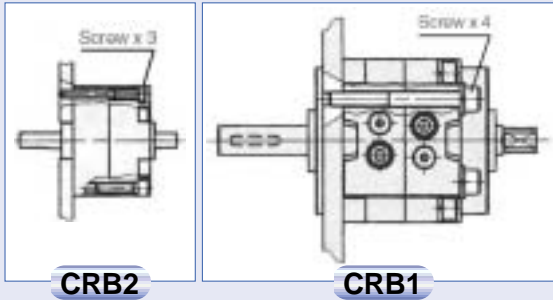

Unrestricted auto switch mounting position

Since the switches can be moved anywhere along the circumference of rotary actuator, they can be mounted at the optimum position according to the rotary actuator's specifications.

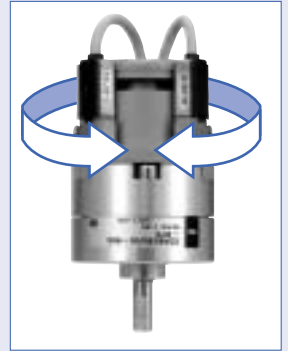

Direct mounting from 3 different directions is possible (CRBU2).

Series CRBU2 can be mounted in 3 directions: axial, top-ported, and side-ported. In the axial direction, there are 3 mounting variations.

Excellent reliability and durability

The use of bearings in all series (CRB2/CRBU2/CRB1) to support thrust and radial loads, along with the implementation of an internal rubber bumper (except for size 10), improves reliability and durability.

Two different connecting port positions (side and axial) are available.

The port position can be selected according to the application. (Only side ports are available for actuators with angle adjuster.)

Low pressure operation

Special seal construction allows for a broader operating pressure range and makes operation in low pressure applications possible.

Minimum operating pressure

Size 10: 0.2MPa

Sizes 15 to 100: 0.15MPa

Axial mounting

Body taps

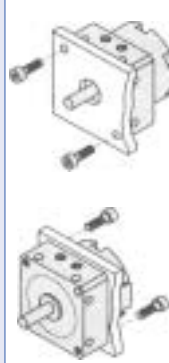

Body through holes

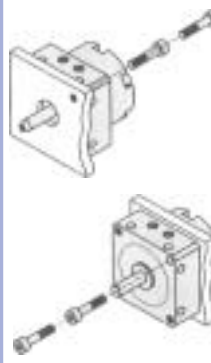

Top-ported mounting

Body through holes

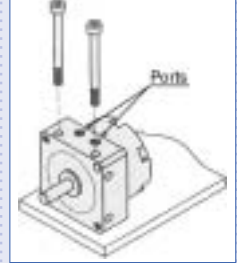

Side-ported mounting

Body through holes

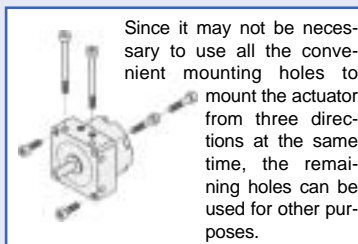

Since it may not be necessary to use all the convenient mounting holes to mount the actuator from three directions at the same time, the remaining holes can be used for other purposes.

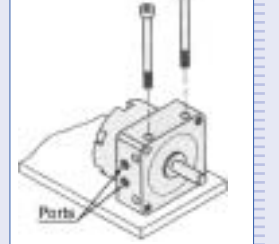

Block (Unit) type construction

Auto switch units and angle adjusters do not protrude beyond the outside diameter of the actuator body, and can be easily retrofitted to any actuator in the series.

Basic type + Switch unit



Rotary Actuator

CRB2
 Sizes: 10, 15, 20, 30, 40



Free-mounting type

CRBU2
 Sizes: 10, 15, 20, 30, 40



CRB1
 Sizes: 50, 63, 80, 100

Double vane construction is now a standard feature for 90° and 100° rotation type actuators.

Although the outside dimensions of the double vane construction actuators are equivalent to those of the single vane construction type (except for size 10), the double vane construction achieves twice the torque of the single vane type.

Model		Rotations					
		90°	100°	180°	190°	270°	280°
CRB2	Single vane	•		•		•	
	Double vane	•	•	•		•	
CRBU2	Single vane	•		•		•	
	Double vane	•	•	•		•	
CRB1	Single vane	•	•	•	•	•	•
	Double vane	•	•	•		•	

Basic type + Angle adjuster



Basic type + Angle adjuster + Switch unit



CRB2

Free-Mounting Type
 CRBU2

CRB1

Rotary Actuator: Vane Type

Series CRB2

Sizes: 10, 15, 20, 30, 40

		Fluid	Air																
		Size	10				15				20, 30				40				
		Vane type	S		D		S		D		S		D		S		D		
		Port position	Side ports	Axial ports	Side ports	Axial ports	Side ports	Axial ports	Side ports	Axial ports	Side ports	Axial ports	Side ports	Axial ports	Side ports	Axial ports	Side ports	Axial ports	
Standard	Rotation	90°	●	●	●	●	●	●	●	●	●	●	●	●	●	●	●	●	
		100°			●	●			●	●			●	●			●	●	
		180°	●	●			●	●			●	●			●	●			
		270°	●	●			●	●			●	●			●	●			
	Shaft type	Double shaft	W	●	●	●	●	●	●	●	●	●	●	●	●	●	●	●	
	Cushion	Rubber bumper																	
	Variations	Basic type		●	●	●	●	●	●	●	●	●	●	●	●	●	●	●	●
		With auto switch		●		●		●		●		●		●		●		●	
		With angle adjuster		●		●		●		●		●		●		●		●	
		With auto switch and angle adjuster		●		●		●		●		●		●		●		●	
Option	Copper-free	20-	●	●	●	●	●	●	●	●	●	●	●	●	●	●	●		
Option	Mounting type	With flange	F	●	●	●	●	●	●	●	●	●	●	●	●	●	●		
Made to Order	Shaft type	Double shaft	Long shaft without single flat & Short shaft with single flat	J	●	●	●	●	●	●	●	●	●	●		●	●	●	
			Long shaft without keyway & Short shaft with single flat													●	●	●	
		Single shaft	Same length double long shaft with single flat on both shafts	Y	●	●	●	●	●	●	●	●	●	●	●				
			Double shaft key													●	●	●	●
	Single shaft	Double round shaft	K	●	●	●	●	●	●	●	●	●	●	●	●	●	●	●	
		Single flat		●	●	●	●	●	●	●	●	●	●	●	●				
			Single shaft key	S												●	●	●	●
	Pattern	Single round shaft	T	●	●	●	●	●	●	●	●	●	●	●	●	●	●	●	●
		Shaft pattern		●	●	●	●	●	●	●	●	●	●	●	●	●	●	●	●
		Rotation pattern		●	●			●	●			●	●			●	●		

CRB2

Free-Mounting Type
CRBU2

CRB1

Rotary Actuator: Vane Type

Series CRB2

Sizes: 10, 15, 20, 30, 40

How to Order

Standard

With auto switch
Sizes: 10, 15

With auto switch
Sizes: 20, 30, 40

CRB2 B W [] **180 S E**

CDRB2 F W [] **180 S 90 L** []

CDRB2 B W [] **180 S R73 L** []

Size

10
15
20
30
40

Connecting port position

Nil	Side ports
E	Axial ports

Number of auto switches

S	1 pc.*
Nil	2 pcs.

Electrical entry/Lead wire length

Nil	Grommet, Lead wire: 0.5m
L	Grommet, Lead wire: 3m
C	Grommet, Lead wire: 0.5m
CL	Grommet, Lead wire: 3m
CN	Grommet, Without lead wire

Auto switch type

Nil	Without auto switch
-----	---------------------

Mounting

B	Basic type
F	Flange type

* When ordering "F" mounting type, flange is shipped together with the actuator, but not mounted.
* Flange can be mounted at 60 degrees intervals.

Standard Shaft type

W	Double shaft with single flat (sizes 10 to 30)
	Long shaft key, Short shaft with single flat (size 40)

Rotation

Vane type	Symbol	Rotation
Single vane	90	90°
	180	180°
	270	270°
Double vane	90	90°
	100	100°

Vane type

S	Single vane
D	Double vane

Notes

- Connectors are available only for auto switch types D-R73, D-R80, D-T79.
- Part numbers for lead wires with connectors, and their respective wire length in (), are: D-LC05 (0.5m); D-LC30 (3m); D-LC50 (5m)

* Fittings are sold separately.

* Right-hand auto switch will be used for actuators with 1 auto switch.

Auto switch specifications: Refer to page 91 for detailed auto switch specifications.

Applicable size	Type	Electrical entry	Indicator light	Wiring (output)	Load voltage		Auto switch part no.	Lead wire type	Lead wire length*				Applicable loads		
					DC	AC			0.5 (Nil)	3 (L)	5 (Z)	None (N)			
For 10 and 15	Reed	Grommet	No	2-wire	24V	5V, 12V	5V, 12V, 24V	90	Parallel cord	●	●	●	—	IC circuit	
						5V, 12V, 100V	5V, 12V, 24V, 100V	90A	Heavy-duty cord	●	●	●	—		
						—	—	97	Parallel cord	●	●	●	—		
						—	100V	93A	Parallel cord	●	●	●	—		
						—	—	T99	Heavy-duty cord	●	●	—	—		
	Solid state	Grommet	Yes	2-wire	24V	12V	—	T99V	Heavy-duty cord	●	●	—	—	Relay PLC	
								S99	Heavy-duty cord	●	●	—	—		
								S99V	Heavy-duty cord	●	●	—	—		
								S9P	Heavy-duty cord	●	●	—	—		
								S9PV	Heavy-duty cord	●	●	—	—		
For 20, 30, and 40	Reed	Grommet	Yes	2-wire	24V	—	100V	R73	Heavy-duty cord	●	●	—	—	IC circuit	
								Connector	Heavy-duty cord	●	●	●	●		
								Grommet	Heavy-duty cord	●	●	—	—		
								Connector	Heavy-duty cord	●	●	●	●		
								Connector	Heavy-duty cord	●	●	●	●		
	Solid state	Grommet	No	2-wire	24V	48V, 100V	24V, 48V, 100V	—	R80	Heavy-duty cord	●	●	—	—	IC circuit
									R80C	Heavy-duty cord	●	●	●	●	
									T79	Heavy-duty cord	●	●	—	—	
									T79C	Heavy-duty cord	●	●	●	●	
									S79	Heavy-duty cord	●	●	—	—	
Grommet	Yes	3-wire (NPN)	—	5V, 12V	—	—	—	S7P	Heavy-duty cord	●	●	—	—	IC circuit	
								3-wire (PNP)	Heavy-duty cord	●	●	—	—		

* Lead wire length symbol 0.5m Nil (Example) R73C 3m L (Example) R73CL
5m Z (Example) R73CZ None N (Example) R73CN

Flange Assembly Part No.

(Refer to page 6 for detailed specifications.)

Model	Assembly part no.
CRB2FW10	P211070-2
CRB2FW15	P211090-2
CRB2FW20	P211060-2
CRB2FW30	P211080-2

2

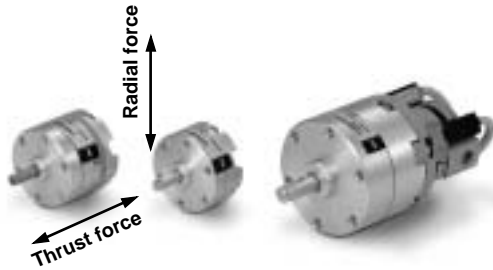

Single Vane Specifications

Model (Size)	CRB2BW10-□S	CRB2BW15-□S	CRB2BW20-□S	CRB2BW30-□S	CRB2BW40-□S	
Vane type	Single vane					
Rotation	90°, 180°, 270°	90°, 180°, 270°	90°, 180°, 270°			
Fluid	Air (non-lube)					
Proof pressure (MPa)	1.05			1.5		
Ambient and fluid temperature	5° to 60°C					
Max. operating pressure (MPa)	0.7			1.0		
Min. operating pressure (MPa)	0.2	0.15				
Speed regulation range (sec/90°) ^{Note 1)}	0.03 to 0.3			0.04 to 0.3	0.07 to 0.5	
Allowable kinetic energy (J) ^{Note 2)}	0.00015	0.001	0.003	0.02	0.04	
		0.00025	0.0004	0.015	0.03	
Shaft load	Allowable radial load (N)	15	15	25	30	60
	Allowable thrust load (N)	10	10	20	25	40
Bearing type	Ball bearing					
Port position	Side ports or axial ports					
Size	Side ports	M5 x 0.8	M3 x 0.5	M5 x 0.8	M3 x 0.5	M5 x 0.8
	Axial ports	M3 x 0.5			M5 x 0.8	
Shaft type	Double shaft (with single flat on both shafts)					Double shaft (Long shaft key & single flat)
Adjustable angle range	0° to 230°		0° to 240°		0° to 230°	
Mounting	Basic, Flange				Basic	
Auto switch	Mountable (Side ports only)					

Double Vane Specifications

Model (Size)	CRB2BW10-□D	CRB2BW15-□D	CRB2BW20-□D	CRB2BW30-□D	CRB2BW40-□D	
Vane type	Double vane					
Rotation	90°, 100°					
Fluid	Air (non-lube)					
Proof pressure (MPa)	1.05			1.5		
Ambient and fluid temperature	5° to 60°C					
Max. operating pressure (MPa)	0.7			1.0		
Min. operating pressure (MPa)	0.2	0.15				
Speed regulation range (sec/90°) ^{Note 1)}	0.03 to 0.3			0.04 to 0.3	0.07 to 0.5	
Allowable kinetic energy (J)	0.0003	0.0012	0.0033	0.02	0.04	
Shaft load	Allowable radial load (N)	15	15	25	30	60
	Allowable thrust load (N)	10	10	20	25	40
Bearing type	Ball bearing					
Port position	Side ports or axial ports					
Port size (Side ports, Axial ports)	M3 x 0.5			M5 x 0.8		
Shaft type	Double shaft (double shaft with single flat on both shafts)					
Adjustable angle range	0° to 90°					
Mounting	Basic, Flange					
Auto switch	Mountable (Side ports only)					

JIS symbol

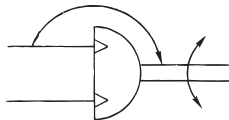

* The following notes apply to both Single and Double Vane Specification tables above.
 Note 1) Make sure to operate within the speed regulation range.
 Exceeding the maximum speed (0.3 sec/90°) can cause the unit to stick or not operate.
 Note 2) The upper numbers in this section indicate the energy factor when the rubber bumper is used (at the end of the rotation), and the lower numbers indicate the energy factor when the rubber bumper is not used.

Volume of the chambers

Vane type	Single vane										Double vane																
	CRB2BW10-□S		CRB2BW15-□S		CRB2BW20-□S		CRB2BW30-□S		CRB2BW40-□S		CRB2BW10-□D		CRB2BW15-□D		CRB2BW20-□D		CRB2BW30-□D		CRB2BW40-□D								
Rotation	90°	180°	270°	90°	180°	270°	90°	180°	270°	90°	180°	270°	90°	180°	270°	90°	100°	90°	100°	90°	100°	90°	100°	90°	100°	90°	100°
Volume (cm³)	1 (0.6)	1.2	1.5	1.5 (1.0)	2.9	3.7	4.8 (3.6)	6.1	7.9	11.3 (8.5)	15	20.2	25 (18.7)	31.5	41	1.0	1.1	2.6	2.7	5.6	5.7	14.4	14.5	33	34		

* Values inside () are volume of the supply side when A port is pressurized.

Weights

Vane type	Single vane										Double vane																
	CRB2BW10-□S		CRB2BW15-□S		CRB2BW20-□S		CRB2BW30-□S		CRB2BW40-□S		CRB2BW10-□D		CRB2BW15-□D		CRB2BW20-□D		CRB2BW30-□D		CRB2BW40-□D								
Rotation	90°	180°	270°	90°	180°	270°	90°	180°	270°	90°	180°	270°	90°	180°	270°	90°	100°	90°	100°	90°	100°	90°	100°	90°	100°	90°	100°
Body of rotary actuator	26.3	26.0	25.7	50	49	48	106	105	103	203	198	193	387	376	365	42	43	57	60	121	144	223	243	400	446		
Flange assembly	9			10			19			25			—			9		10		19		25		—			
Auto switch unit + 2 switches	30			30			50			60			46.5			30		30		50		60		46.5			
Angle adjuster	30			47			90			150			203			30		47		90		150		203			

Series CRB2

Rotary Actuator: Semi-standard options for the shaft

Rotary actuators can be ordered with following semi-standard shaft options.

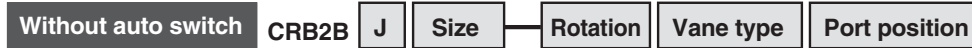

• Shaft type

Symbol	Shaft type	Shaft-end shape	Size				
			10	15	20	30	40
J	Double shaft	Long shaft without single flat & with single flat	●	●	●	●	
		Long shaft without keyway & with single flat					●
K	Double shaft	Double round shaft					●
S	Single shaft	Single shaft with single flat	●	●	●	●	
		Single shaft key					●
T	Single shaft	Single round shaft	●	●	●	●	●
Y	Double shaft	Double shaft with single flat	●	●	●	●	
		Double shaft key					●

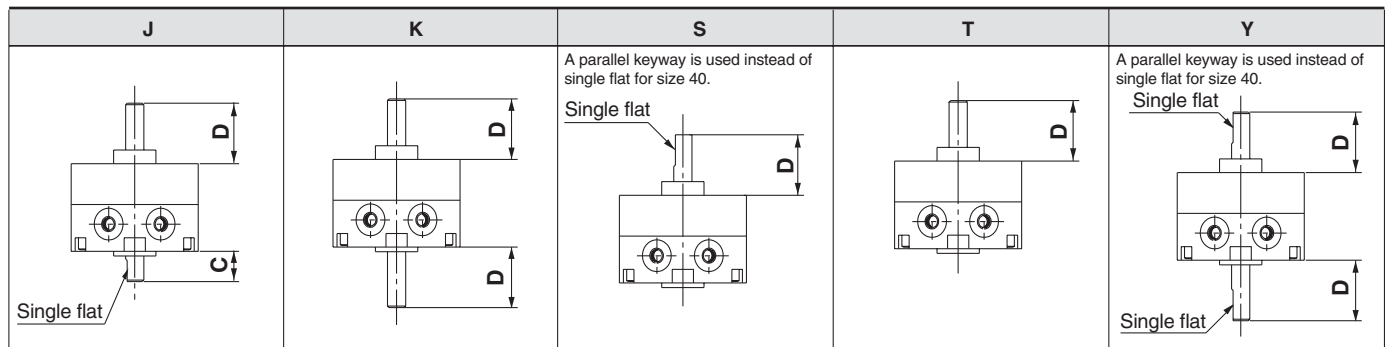

(mm)

Size	10	15	20	30	40
C	8	9	10	13	15
D	14	18	20	22	30

Notes) • Only side ports are available except for basic type.

- Dimensions and tolerance of the shaft and single flat (a parallel keyway for size 40) are the same as the standard.



• With angle adjuster

• Shaft type

With auto switch

Symbol	Shaft type	Shaft-end shape	Size				
			10	15	20	30	40
J	Double shaft	Long shaft without single flat & with single flat	●	●	●	●	
		Long shaft without keyway & with single flat					●

"J" option is the only semi-standard shaft option available for autoswitch or adjuster rotary actuators.

(mm)

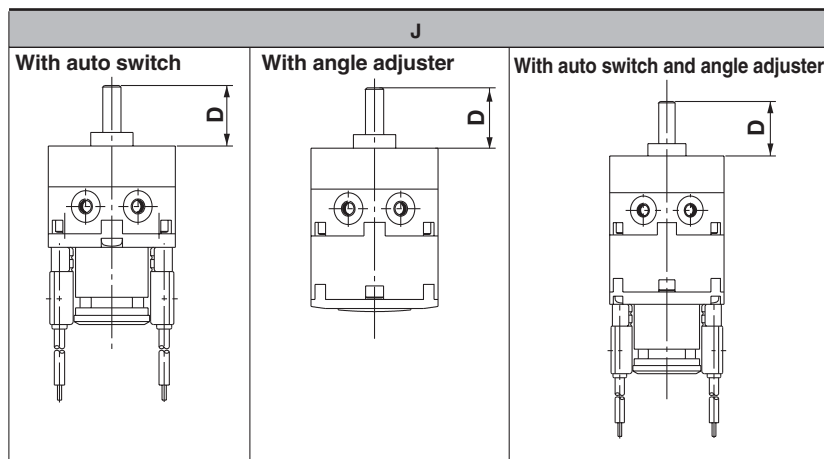

Size	10	15	20	30	40
C	8	9	10	13	15
D	14	18	20	22	30

Notes) • Only side ports are available except for basic type.

- Dimensions and tolerance of the shaft and single flat (a parallel keyway for size 40) are the same as the standard.

Copper-Free Rotary Actuator

20 – CRB2BW Size Rotation Vane type Port position

↓ Copper-free

Use the standard vane type rotary actuators in all series to prevent any adverse effects to colour CRTs* due to copper ions or fluororesin.

Specifications

Vane type	Single/Double vane				
	10	15	20	30	40
Operating pressure range (MPa)	0.2 to 0.7	0.15 to 0.7	0.15 to 1.0		
Speed regulation range (s/90°)	0.03 to 0.3		0.04 to 0.3	0.07 to 0.5	
Port position	Side ports or axial ports				
Piping	Screw-in piping				
Mounting	Basic type only				
Variations	Basic type, with auto switch, with angle adjuster				

*CRT= Cathode ray tubes

Specific Product Precautions

Be sure to read before handling.
Refer to pages 104 through 110 for safety instructions, actuator precautions, and auto switch precautions.

Angle Adjuster

Caution

1. In case of a rotary actuator for a 90° or 180° application, the maximum angle will be limited by the rotation of the rotary actuator itself. Make sure to take this into consideration when ordering.

In case of a rotary actuator for a 90° or 180° application, angle adjustment at the maximum angle of 90° or 180°, respectively, is not feasible. This is due to the fact that the rotation of the rotary actuator is limited to 90° $^{+4}_{0}$ ° or 180° $^{+4}_{0}$ °, respectively.

Therefore, for the single vane type, use a rotary actuator with a rotation angle of 270°, and for the double vane type, use a rotary actuator with a rotation of 100°.

When operating a rotary actuator with a rotation of 90° or 180°, the rotation should be adjusted to within 85° and 175°, respectively, as a guide.

2. Connecting ports are side ports only.

3. The allowable kinetic energy is the same as the specifications of the rotary actuator by itself (i.e., without angle adjuster).

Series CRB2

Optional Specifications: Flange (Sizes: 10, 15, 20, 30)



Standard type	Model			Flange assembly part no.
	With auto switch	With angle adjuster	With angle adjuster and auto switch	
CRB2FW10	CDRB2FW10	CRB2FWU10	CDRB2FWU10	P211070-2
CRB2FW15	CDRB2FW15	CRB2FWU15	CDRB2FWU15	P211090-2
CRB2FW20	CDRB2FW20	CRB2FWU20	CDRB2FWU20	P211060-2
CRB2FW30	CDRB2FW30	CRB2FWU30	CDRB2FWU30	P211080-2



Notes) The flange (with countersunk head screws) is not mounted on the actuator at the time of shipment.
The flange can be mounted on the rotary actuator at 60-degree intervals.

Assembly Part No.: P211070-2 (for C□RB2FW□10)

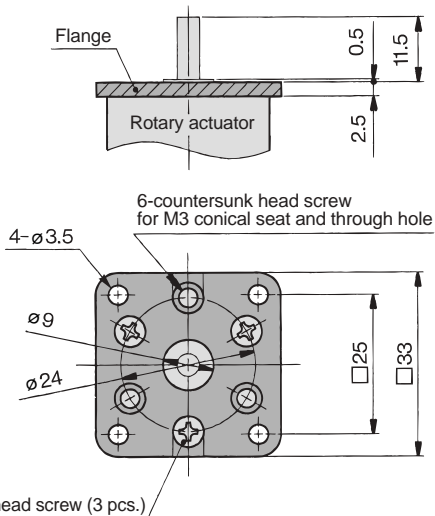

Assembly Part No.: P211090-2 (for C□RB2FW□15)

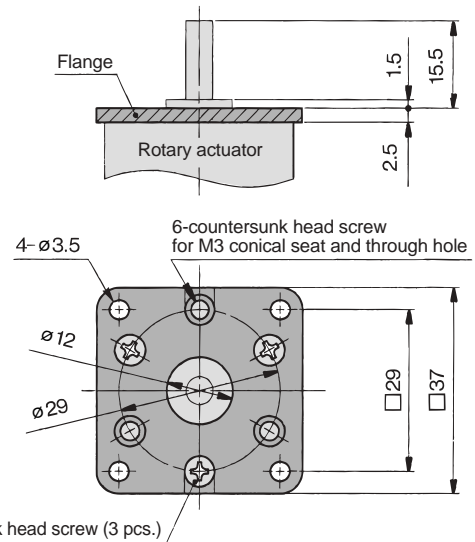

Assembly Part No.: P211060-2 (for C□RB2FW□20)

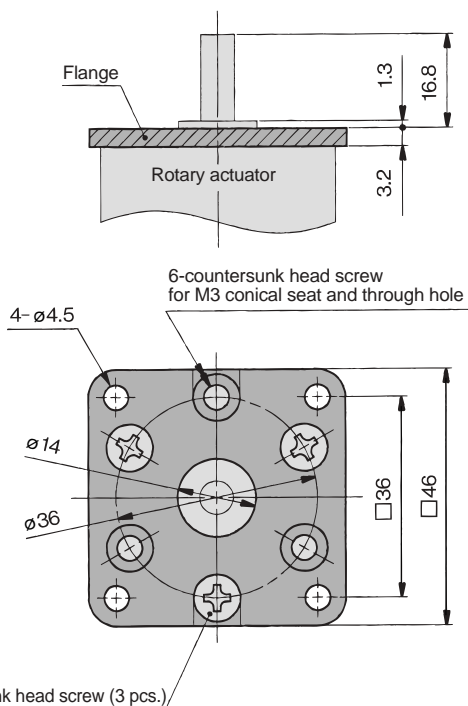

Assembly Part No.: P211080-2 (for C□RB2FW□30)

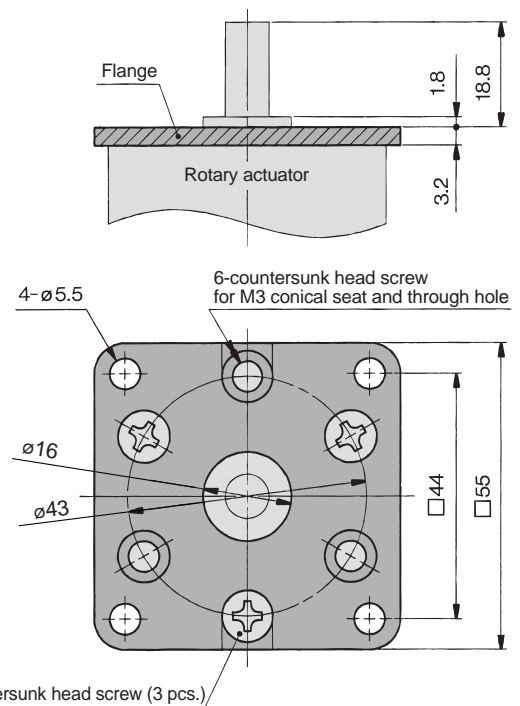

Effective Output

Direct Mounting of Body

CRB2BW10

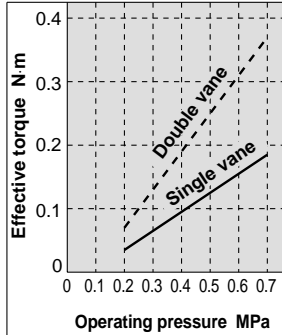

CRB2BW15

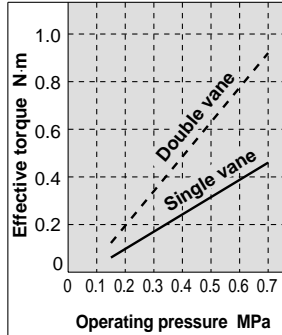

CRB2BW20

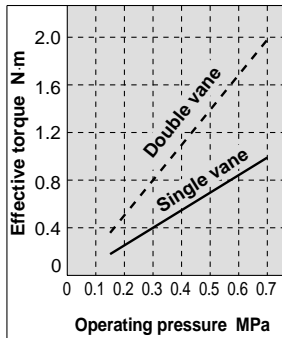

CRB2BW30

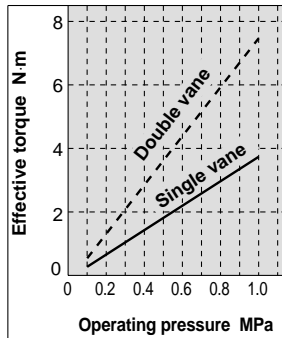

CRB2BW40

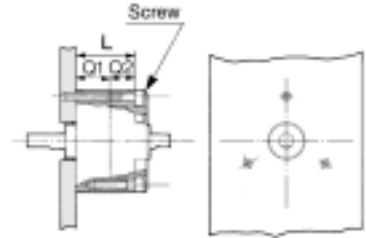
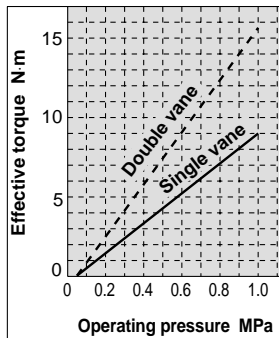

Dimension "L" of the actuators is provided in the table below for JIS standard hexagon socket head cap screws. If these types of screw are used, their heads will fit in the mounting hole.

Type	L	Screw
CRB2BW10	11.5*	M2.5
CRB2BW15	16	M2.5
CRB2BW20	24.5	M3
CRB2BW30	34.5	M4
CRB2BW40	39.5	M4

* Only the size 10 actuators have different L dimensions for single and double vane. L dimension for size 10 double vane actuator is 20.5.

* Refer to pages 10 and 11 for Q1 and Q2 dimensions.

Chamfered Position and Rotation Range: Top View from Long Shaft Side

(Chamfered positions shown below illustrate the conditions of actuators when B port is pressurized.)

Single vane type

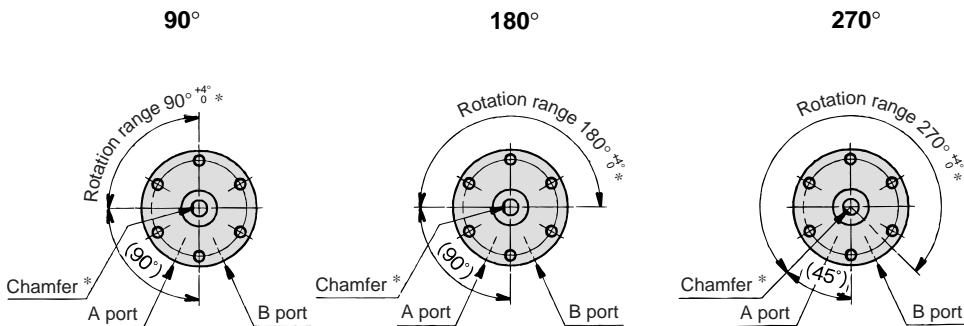

Double vane type

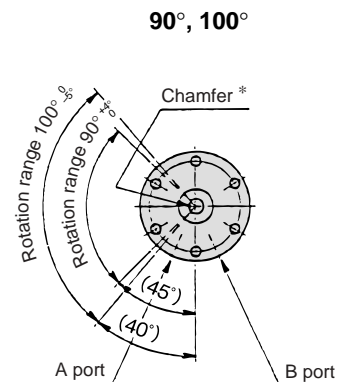

* For size 40 actuators, a parallel keyway will be used instead of chamfer.
 Note) For single vane type, rotation tolerance of 90°, 180°, and 270° actuators will be $^{+5^\circ}_0$ for size 10 actuators only.
 For double vane type, rotation tolerance of 90° actuator will be $^{+5^\circ}_0$ for size 10 actuators only.

CRB2

Free-Mounting Type
CRBU2

CRB1

Series CRB2

Construction: 10, 15, 20, 30, 40

Single vane type

- Illustrations below show size 20 actuators.
- Illustrations for 90° and 180° show the condition of the actuators when B port is pressurized, and the illustration for 270° shows the position of the ports during rotation.

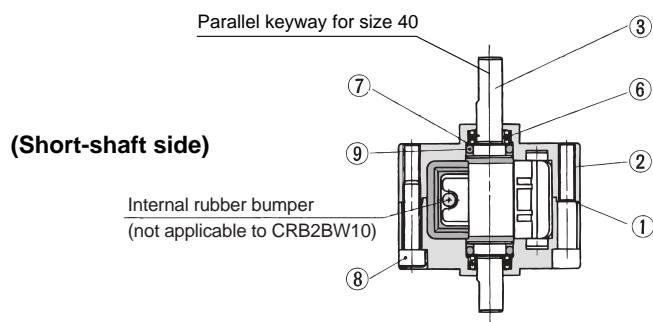
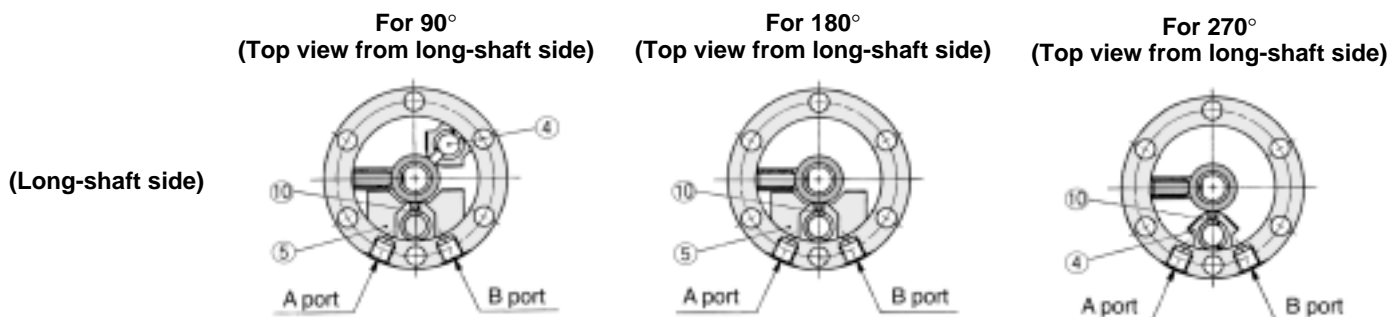

Parts list

No.	Description	Material	Note
1	Body (A)	Aluminum alloy	White
2	Body (B)	Aluminum alloy	White
3	Vane shaft	Stainless steel*	
4	Stopper	Resin	For 270°
5	Stopper	Resin	For 180°
6	Bearing	High carbon chromium steel	
7	Back-up ring	Stainless steel	
8	Hexagon socket head cap screw	Stainless steel	Special screw
9	O-ring	NBR	
10	Stopper seal	NBR	Special seal

* Carbon steel for CRB2BW30 and CRB2BW40.

Double vane type

CRB2BW10-□D • Illustrations below show the intermediate rotation position when A or B port is pressurized.

CRB2BW15, 20, 30, 40-□D • Illustrations below show size 20 actuators.

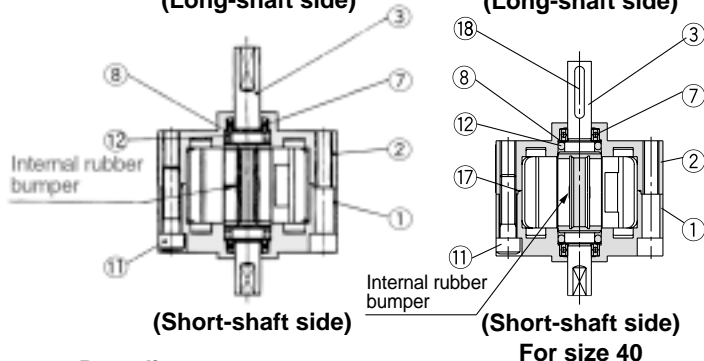
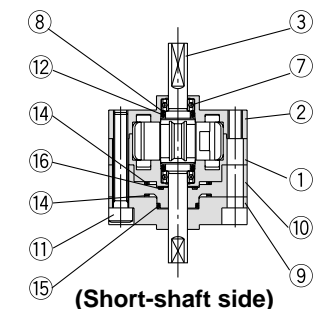
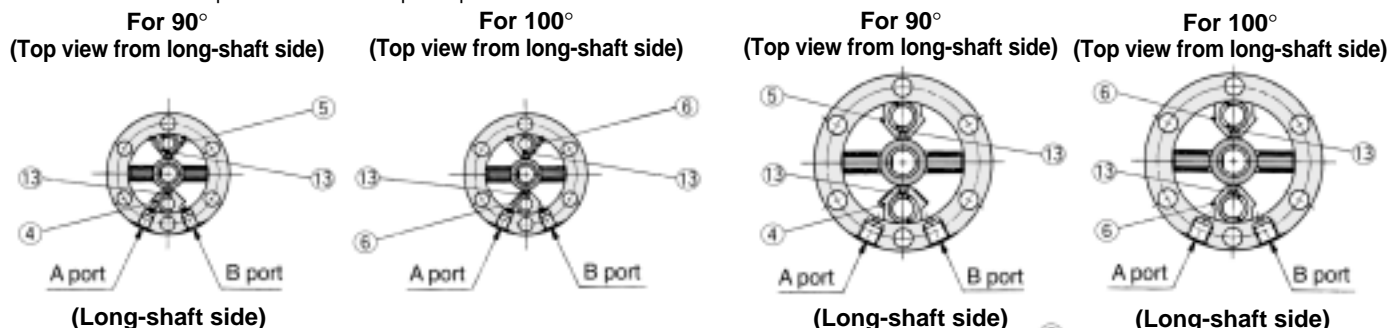

Parts list

No.	Description	Material	Note
1	Body (A)	Aluminum alloy	White
2	Body (B)	Aluminum alloy	White
3	Vane shaft	Carbon steel	
4	Stopper	Stainless steel	
5	Stopper	Resin	
6	Stopper	Stainless steel	
7	Bearing	High carbon chromium steel	
8	Back-up ring	Stainless steel	
9	Cover	Aluminum alloy	White

Parts list

No.	Description	Material	Note
10	Plate	Resin	White
11	Hexagon socket head cap screw	Stainless steel	Special screw
12	O-ring	NBR	
13	Stopper seal	NBR	Special seal
14	Gasket	NBR	Special seal
15	O-ring	NBR	
16	O-ring	NBR	
17	O-ring	NBR	Double vane only
18	Parallel keyway	Carbon steel	Size 40 only

Construction (with Auto Switch Unit)

- Single vane type
Following illustrations show actuators for 90° and 180° when B port is pressurized.
- Double vane type
Following illustrations show the intermediate rotation position when A or B port is pressurized.

(Same switch units are used for both single and double vane types.)

CDRB2BW10, 15-□^S_D

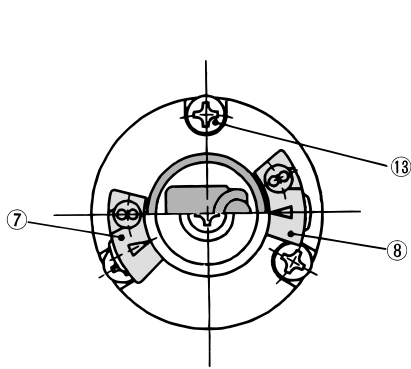

CDRB2BW20, 30-□^S_D

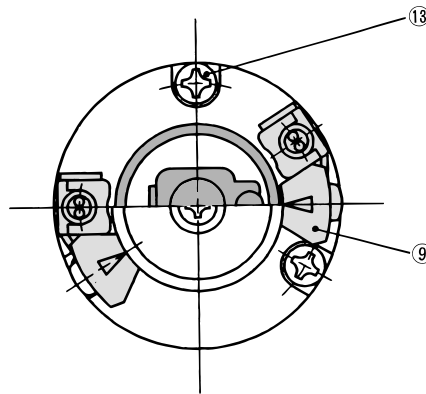

CDRB2BW40-□^S_D

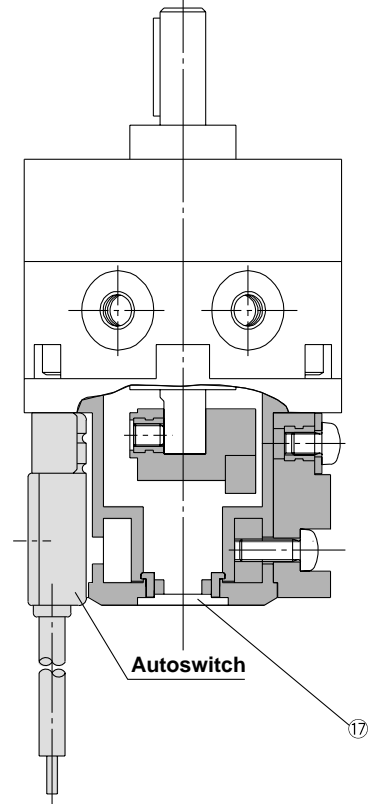
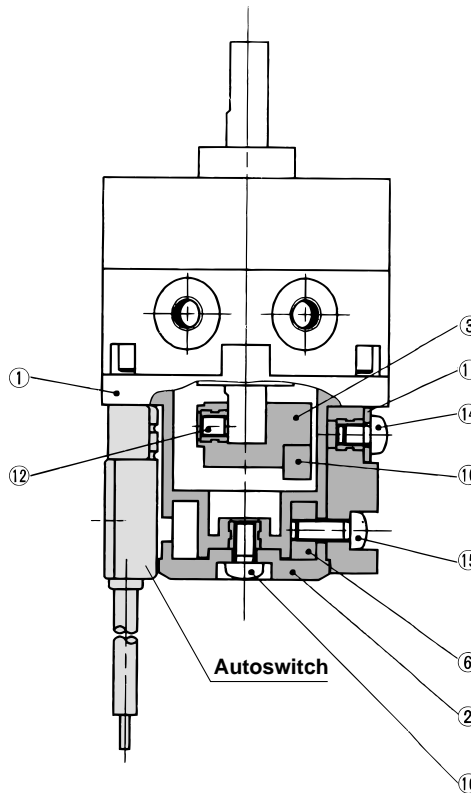
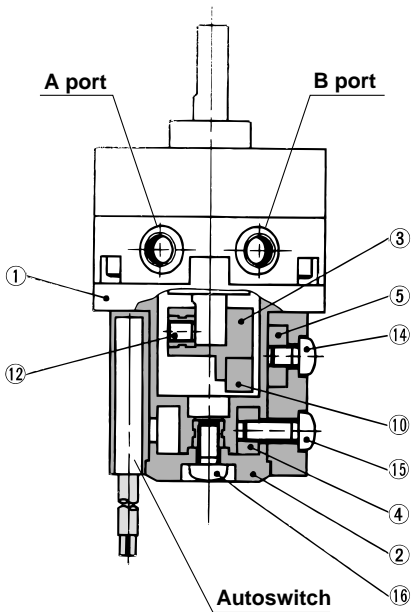
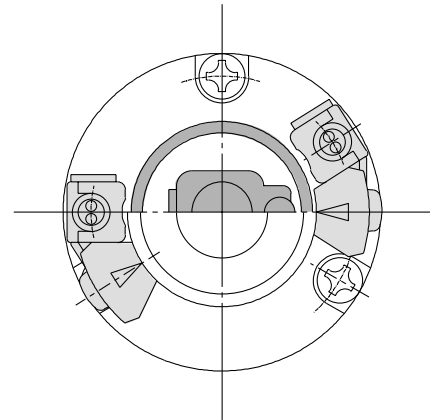

Parts list

No.	Description	Material
1	Cover (A)	Resin
2	Cover (B)	Resin
3	Magnet lever	Resin
4	Holding block (A)	Aluminum alloy
5	Holding block (B)	Aluminum alloy
6	Holding block	Aluminum alloy
7	Switch block (A)	Resin
8	Switch block (B)	Resin
9	Switch block	Resin
10	Magnet	Magnetic body

No.	Description	Material
11	Arm	Stainless steel
12	Hexagon socket head set screw	Stainless steel
13	Round head Phillips screw	Stainless steel
14	Round head Phillips screw	Stainless steel
15	Round head Phillips screw	Stainless steel
16	Round head Phillips screw	Stainless steel
17	Rubber cap	NBR

* For CDRB2BW10, 2 round head Phillips screws, ⑬, are required.

Series CRB2

Dimensions: 10, 15, 20, 30

Single vane type

• Following illustrations show actuators for 90° and 180° when B port is pressurized.

CRB2BW□-□S

<Port position: Side ports>

CRB2BW10-□S
<Port position: Side ports>

2-M3 x 0.5 with depth 4
Size 10 only (for mounting unit)

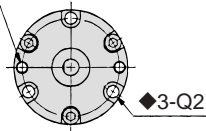

CRB2BW□-□SE
<Port position: Axial ports>

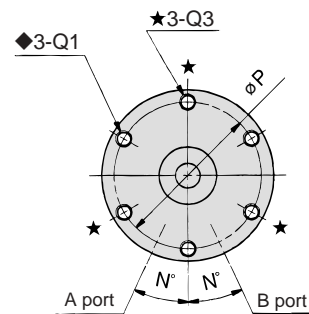
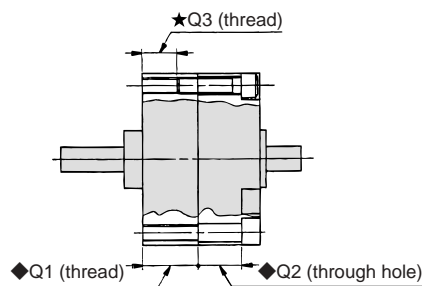
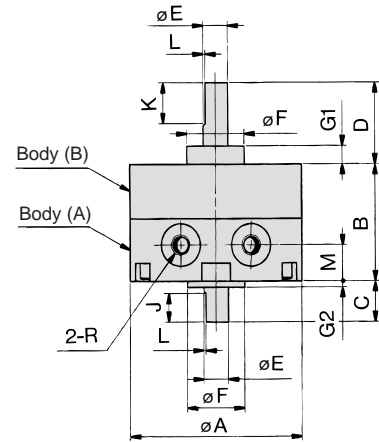
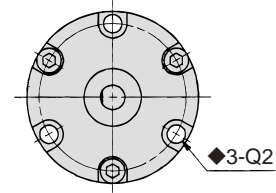
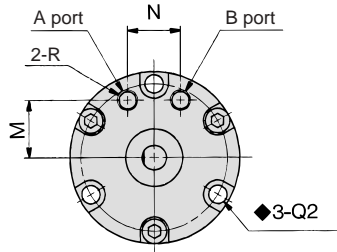

Note) Depths of Q1 and Q2 with the \blacklozenge mark indicate that the holes go through both bodies (A) and (B).



Note) The pre-drilled mounting threads for CRB2BW15, 20, and 30, 3 mounting holes depicted with the \star marks are for tightening the actuator and not to be used for external mounting.

Model	A	B	C	D	E (g6)	F (h9)	G1	G2	J	K	L	M	N	P	◆Q1	◆Q2	★Q3	R			
																		90°	180°	270°	
CRB2BW10-□S	29	15	8	14	4 ^{-0.004} _{-0.012}	9 ⁰ _{-0.036}	3	1	5	9	0.5	5	25	24	M3	3.4	—		M5	M3	
CRB2BW10-□SE												8.5	9.5								
CRB2BW15-□S	34	20	9	18	5 ^{-0.004} _{-0.012}	12 ⁰ _{-0.043}	4	1.5	6	10	0.5	5	25	29	M3	3.4	M3		M5	M3	
CRB2BW15-□SE												11	10								
CRB2BW20-□S	42	29	10	20	6 ^{-0.004} _{-0.012}	14 ⁰ _{-0.043}	4.5	1.5	7	10	0.5	9	25	36	M4	4.5	M4		M5		
CRB2BW20-□SE												14	13								
CRB2BW30-□S	50	40	13	22	8 ^{-0.005} _{-0.014}	16 ⁰ _{-0.043}	5	2	8	12	1.0	10	25	43	M5	5.5	M5		M5		
CRB2BW30-□SE												15.5	14								

Double vane type • Following illustrations show the intermediate rotation position when A or B port is pressurized.

CRB2BW10-□DE
<Port position: Axial ports>

CRB2BW15, 20, 30-□DE
<Port position: Axial ports>

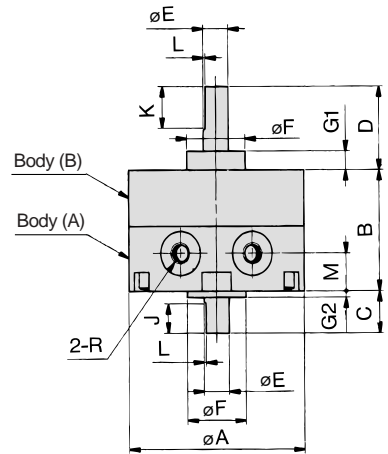
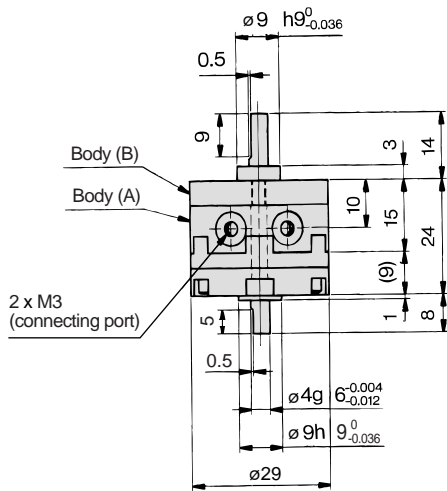
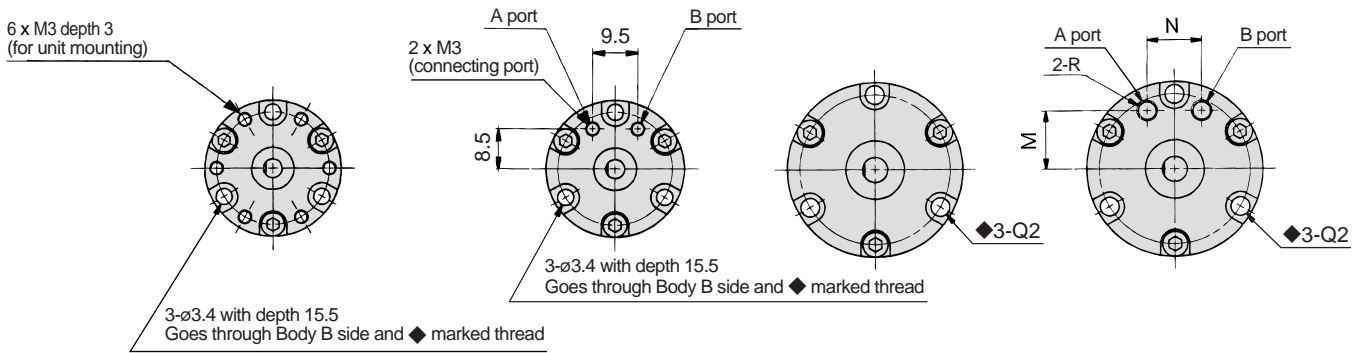

CRB2BW10-□D
<Port position: Side ports>

CRB2BW15, 20, 30-□D
<Port position: Side ports>

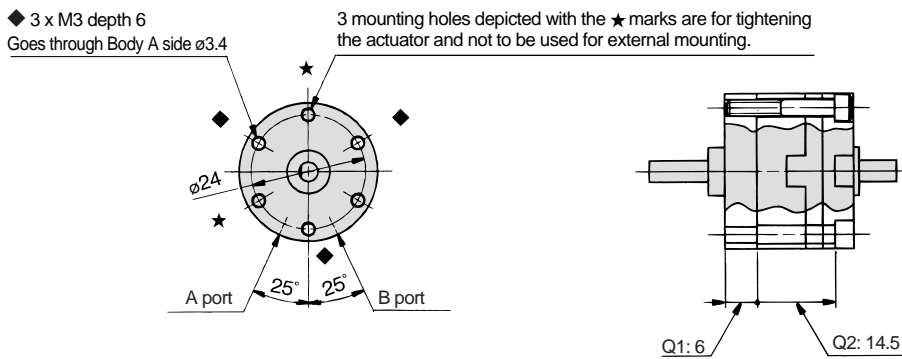

Model	A	B	C	D	E (g6)	F (h9)	G1	G2	J	K	L	M	N	P	Q (depth)			R	
															◆Q1	◆Q2	★Q3	90°	100°
CRB2BW15-□D	34	20	9	18	$5^{0.004}_{-0.012}$	$12^0_{-0.043}$	4	1.5	6	10	0.5	5	25	29	M3 (10)	3.4 (6)	M3 (5)	M3	
CRB2BW15-□DE																			
CRB2BW20-□D	42	29	10	20	$6^{0.004}_{-0.012}$	$14^0_{-0.043}$	4.5	1.5	7	10	0.5	9	25	36	M4 (13.5)	4.5 (11)	M4 (7.5)	M5	
CRB2BW20-□DE																			
CRB2BW30-□D	50	40	13	22	$8^{0.005}_{-0.014}$	$16^0_{-0.043}$	5	2	8	12	1.0	10	25	43	M5 (18)	5.5 (16.5)	M5 (10)	M5	
CRB2BW30-□DE																			

Series CRB2

Dimensions: 40

Single vane/Double vane type

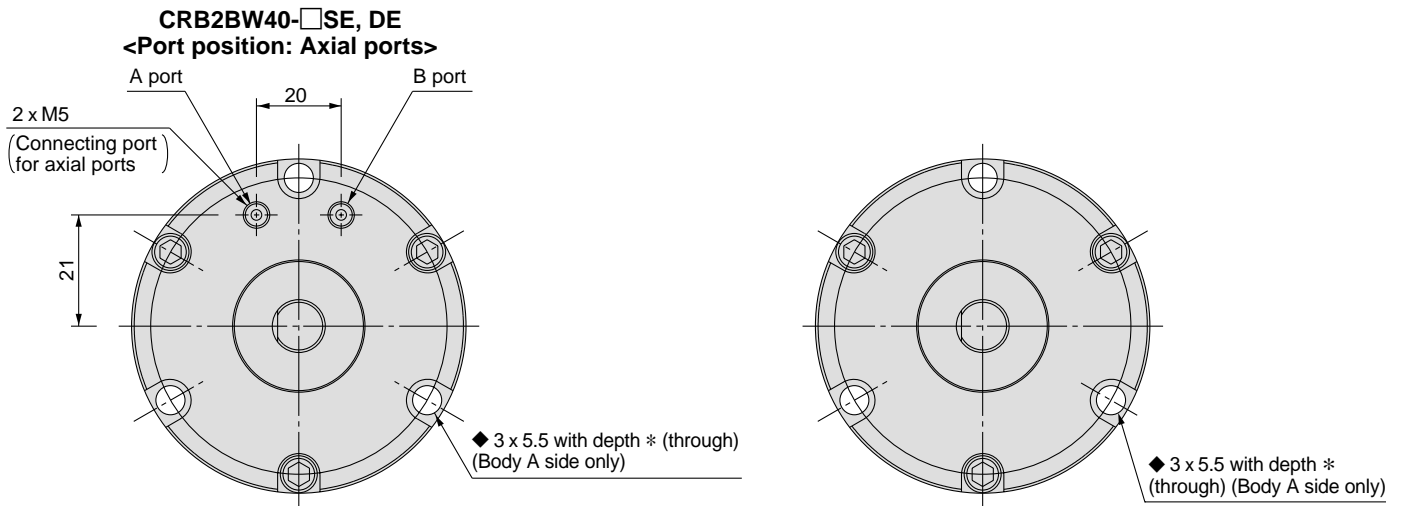

Vane type	*
Single vane	17.5
Double vane	23.5

Keyway dimensions			
	b (h9)	h (h9)	L
CRB2BW40-□□□	4 ⁰ _{-0.030}	4 ⁰ _{-0.030}	20

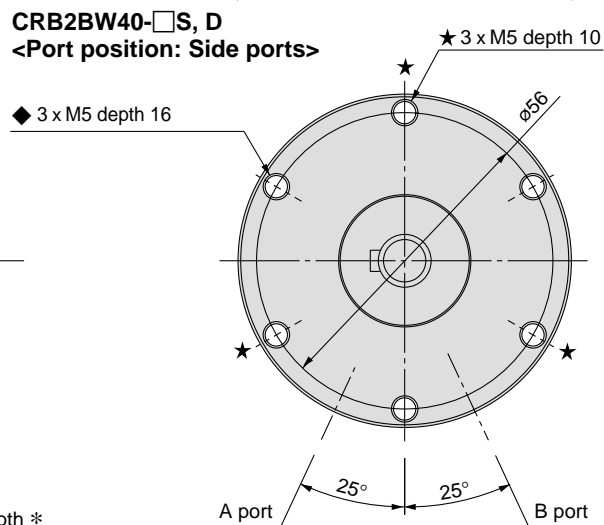
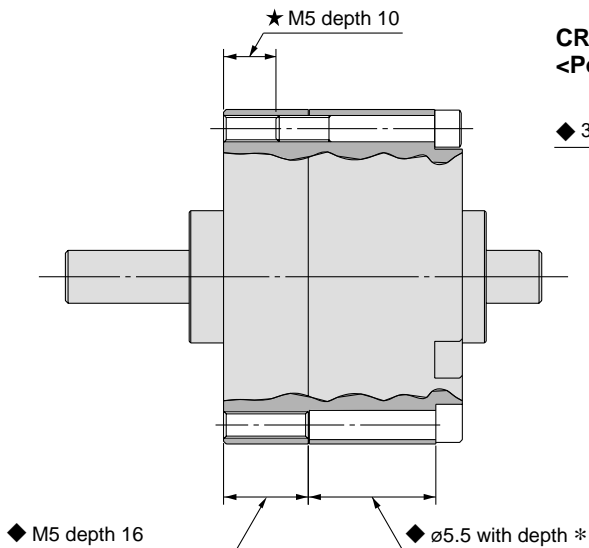
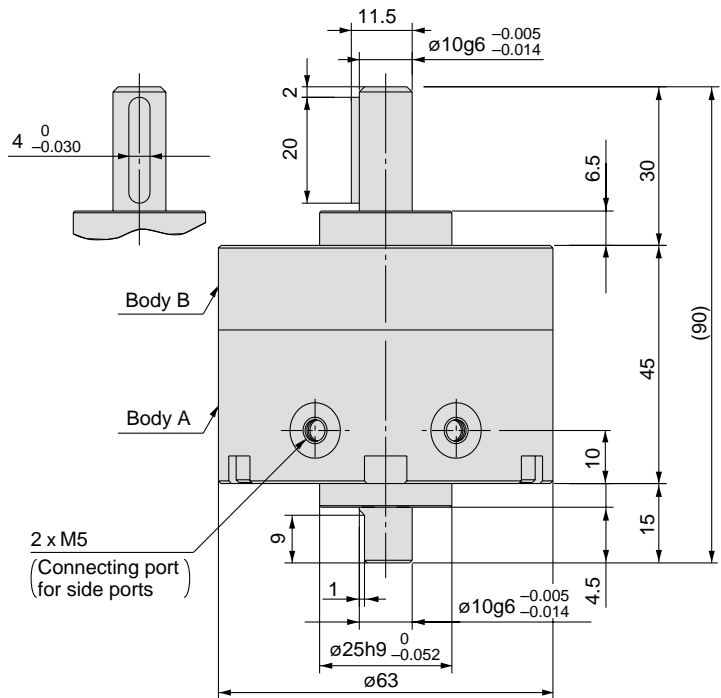

Dimensions: 10, 15, 20, 30 (with Auto Switch Unit)

Single vane type
CDRB2BW10, 15-□S

• Following illustrations show actuators for 90° and 180° when B port is pressurized.
CDRB2BW20, 30-□S

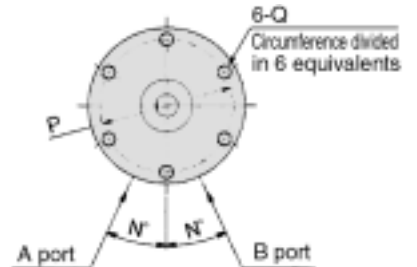
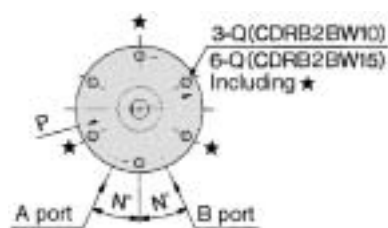
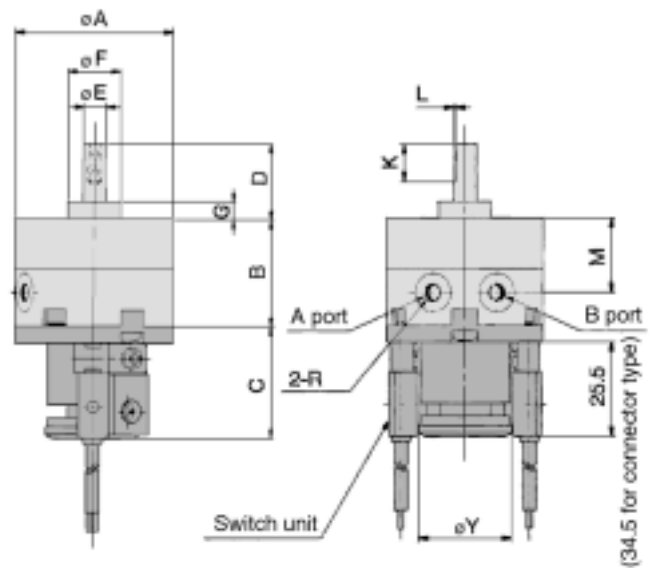
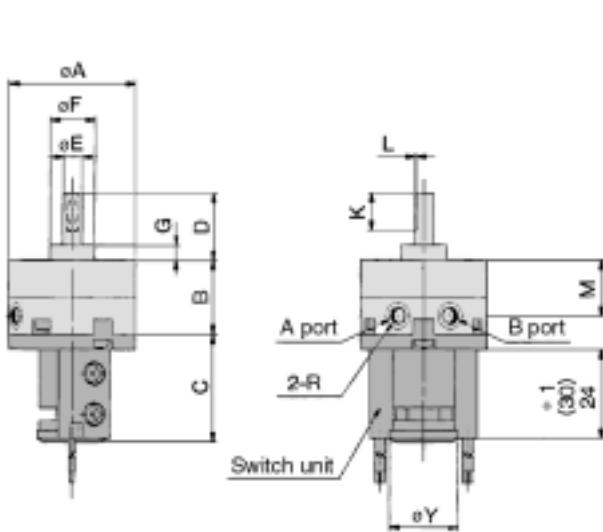
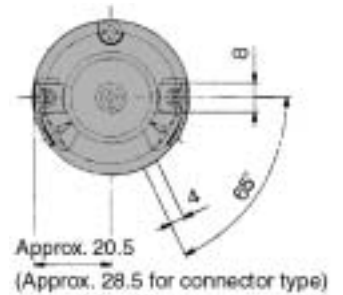
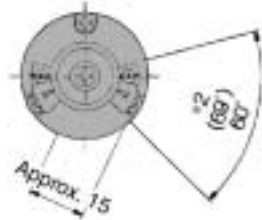

*1 The length is 24 when any of the following auto switches are used: D-90, D-90A, D-S99(V), D-T99(V), and D-S9P(V)

The length is 30 when any of the following auto switches are used: D-97 and D-93A

*2 The angle is 60° when any of the following auto switches are used: D-90, D-90A, D-97, and D-93A.

The angle is 69° when any of the following auto switches are used: D-S99(V), D-T99(V), and D-S9P(V)

Note) • For rotary actuators with auto switch unit, connecting ports are side ports only.

• The above exterior view drawings illustrate rotary actuators with one right-hand and one left-hand switches.

Model	A	B	C	D	E (g6)	F (h9)	G	K	L	M	N	P	Q	R			Y
														90°	180°	270°	
CDRB2BW10-□S	29	15	29	14	4	9	3	9	0.5	10	25	24	M3 depth 5	M5	M3	18.5	
CDRB2BW15-□S	34	20	29	18	5	12	4	10	0.5	15	25	29	M3 depth 5	M5	M3	18.5	
CDRB2BW20-□S	42	29	30	20	6	14	4.5	10	0.5	20	25	36	M4 depth 7	M5		25	
CDRB2BW30-□S	50	40	31	22	8	16	5	12	1	30	25	43	M5 depth 10	M5		25	

Series CDRB2

Dimensions: 10, 15, 20, 30 (with Auto Switch Unit)

Double vane type • Following illustrations show the intermediate rotation position when A or B port is pressurized.

CDRB2BW10-□D

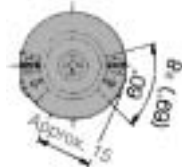

CDRB2BW15-□D

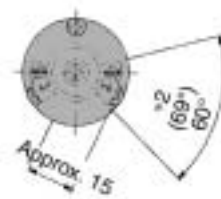

CDRB2BW20, 30-□D

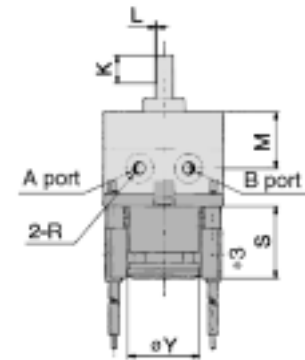
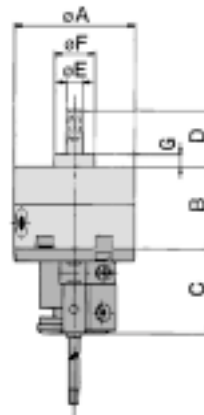
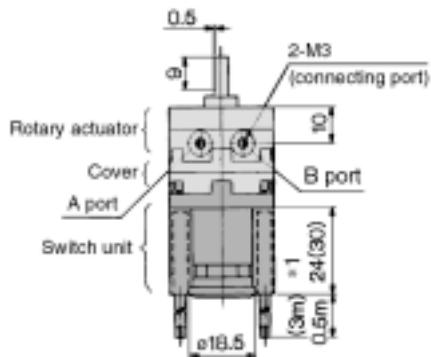
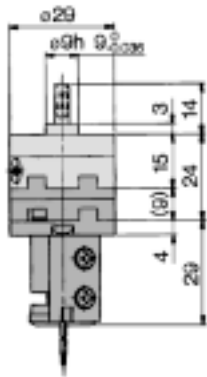
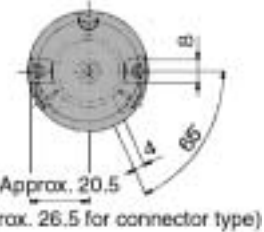

CRB2BW15, 20, 30-□D

(Dimensions are the same as the single vane type.)

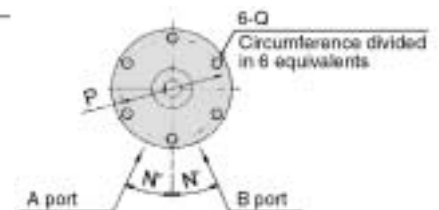
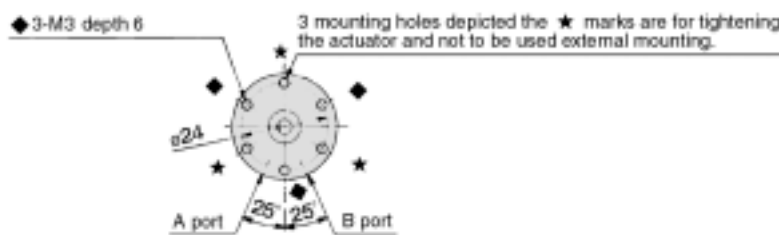

*1 The length is 24 when any of the following auto switches are used: D-90, D-90A, D-S99(V), D-T99(V), and D-S9P(V)
The length is 30 when any of the following auto switches are used: D-97 and D-93A

*2 The angle is 60° when any of the following auto switches are used: D-90, D-90A, D-97, and D-93A.

The angle is 69° when any of the following auto switches are used: D-S99(V), D-T99(V), and D-S9P(V)

*3 The length (Dimension S) is 25.5 when any of the following grommet type auto switches are used: D-R73, D-R80, D-S79, D-T79, and D-S7P
The length (Dimension S) is 34.5 when any of the following connector type auto switches are used: D-R73, D-R80, and D-T79

Model	A	B	C	D	E (g6)	F (h9)	G	K	L	M	N	P	Q	R		S	Y
														90°	100°		
CDRB2BW15-□D	34	20	29	18	5	12	4	10	0.5	15	25	29	M3 x 0.5 with depth 5	M3	24 ^{*1}	30 ^{*1}	18.5
CDRB2BW20-□D	42	29	30	20	6	14	4.5	10	0.5	20	25	36	M4 x 0.7 with depth 7	M5	25.5 ^{*3}	34.5 ^{*3}	25
CDRB2BW30-□D	50	40	31	22	8	16	5	12	1	30	25	43	M5 x 0.8 with depth 10	M5			25

Dimensions: 40 (with Auto Switch Unit)

Single vane/Double vane type

CDRB2BW40-□S, D

Keyway dimensions			
	b (h9)	h (h9)	L
Model	b (h9)	h (h9)	L
CDRB2BW40-□□□	4 ⁰ _{-0.030}	4 ⁰ _{-0.030}	20

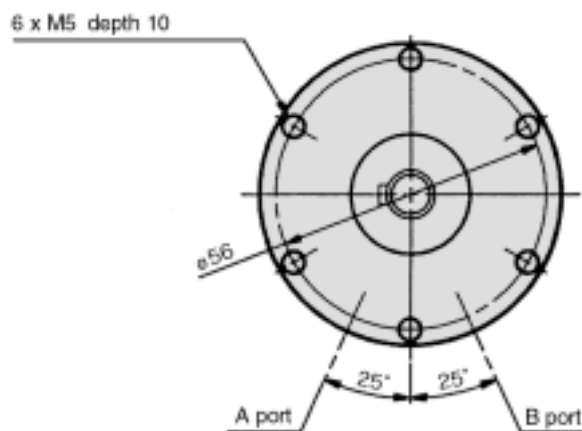
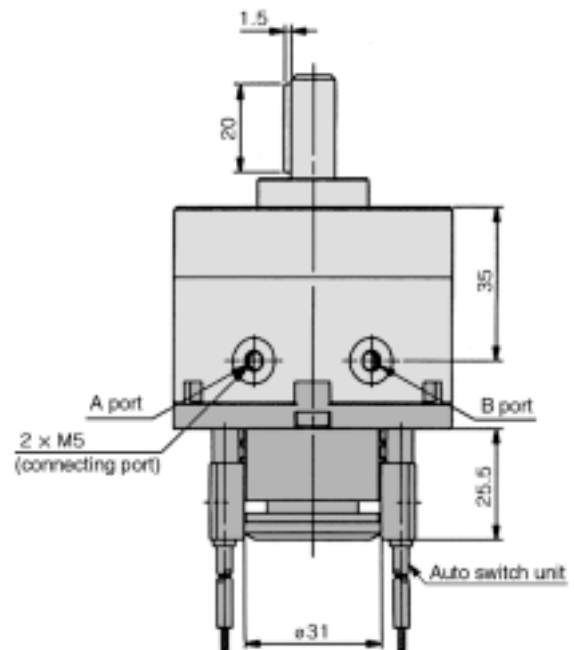
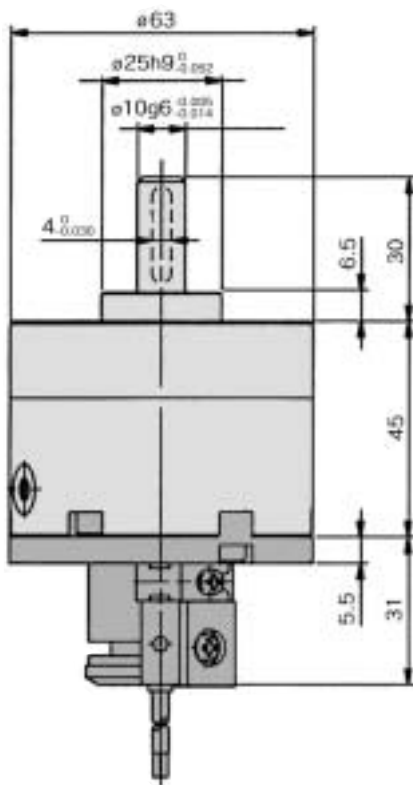
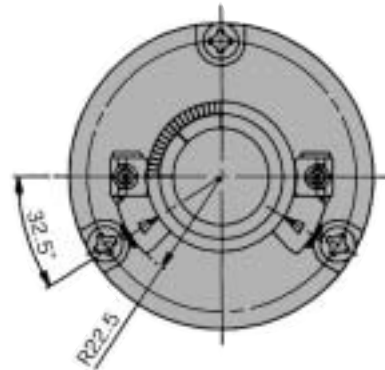

CRB2

Free-Mounting Type
CRBU2

CRB1

Vane Type Rotary Actuator with Angle Adjuster

Series CRB2BWU

Sizes: 10, 15, 20, 30, 40

How to Order

Standard



With auto switch
Sizes: 10, 15

With auto switch
Sizes: 20, 30, 40

With auto switch
(with switch unit)

Mounting

B	Basic type
F	Flange type

* When ordering "F" mounting type, flange is shipped together with the actuator, but not mounted.
* Flange can be mounted at 60 degrees intervals.



CRB2 B WU 10-180 S

CDRB2 F WU 10-180 S-90 L

CDRB2 B WU 20-180 S-R73 L

Size

10
15
20
30
40

Rotation

Vane type	Symbol	Rotation
Single vane	90	90°
	180	180°
	270	270°
Double vane	90	90°
	100	100°

Vane type

S	Single vane
D	Double vane

Auto switch type

Nil	Without auto switch
-----	---------------------

Number of auto switches

S	1 pc.*
Nil	2 pcs.

* Right-hand auto switch will be used for actuators with 1 auto switch.

Electrical entry/Lead wire length

Nil	Grommet, Lead wire: 0.5m
L	Grommet, Lead wire: 3m
C	Grommet, Lead wire: 0.5m
CL	Grommet, Lead wire: 3m
CN	Grommet, Without lead wire

Notes) • Connectors are available only for auto switch types D-R73, D-R80, D-T79.
• Part numbers for lead wires with connectors, and their respective wire length in (), are: D-LC05 (0.5m); D-LC30 (3m); D-LC50 (5m)

Auto switch specifications: Refer to page 91 for detailed auto switch specifications.

Applicable size	Type	Electrical entry	Indicator light	Wiring (output)	Load voltage		Auto switch part no.	Lead wire type	Lead wire length*				Applicable loads			
					DC	AC			0.5 (Nil)	3 (L)	5 (Z)	None (N)				
For 10 and 15	Reed	Grommet	No	2-wire	24V	5V, 12V	24V or less	90	Parallel cord	●	●	●	—	Relay PLC		
						100V or less	90A	Heavy-duty cord	●	●	●	—				
						12V	—	97	Parallel cord	●	●	●	—			
						100V	—	93A	—	●	●	—	—			
						—	—	T99	—	●	●	—	—			
	Solid state	Grommet	Yes	3-wire (NPN)	24V	—	—	—	Heavy-duty cord	T99V	●	●	—	—	IC circuit	
										S99	●	●	—	—		
										S99V	●	●	—	—		
										S9P	●	●	—	—		
										S9PV	●	●	—	—		
For 20, 30, and 40	Reed	Grommet	Yes	2-wire	24V	12V	100V	Heavy-duty cord	R73	●	●	—	—	Relay PLC		
									—	—	R73C	●	●		●	●
									5V, 12V	100V or less	R80	●	●		—	●
									24V or less	24V or less	R80C	●	●		●	—
									—	—	T79	●	●		—	●
	Solid state	Grommet	Yes	3-wire (NPN)	24V	—	—	—	Heavy-duty cord	T79C	●	●	●	—	IC circuit	
										S79	●	●	—	—		
										S7P	●	●	—	—		
										—	—	—	—	—		
										—	—	—	—	—		

* Lead wire length symbol

0.5m Nil	(Example) R73C
3m L	(Example) R73CL
5m Z	(Example) R73CZ
None N	(Example) R73CN

Construction

(Same switch units are used for both single and double vane type.)

With angle adjuster

CRB2BWU10, 15, 20, 30, 40-□^S_D

Double vane

Single vane

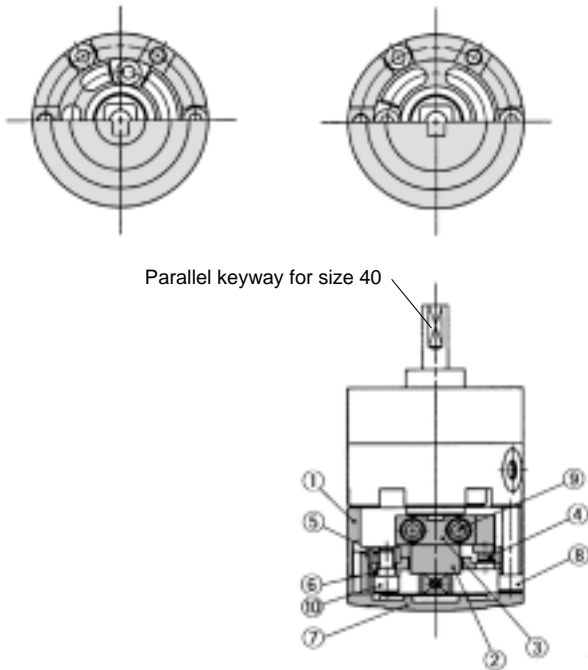

With angle adjuster + Auto switch unit

CDRB2BWU10, 15-□^S_D

CDRB2BWU20, 30, 40-□^S_D

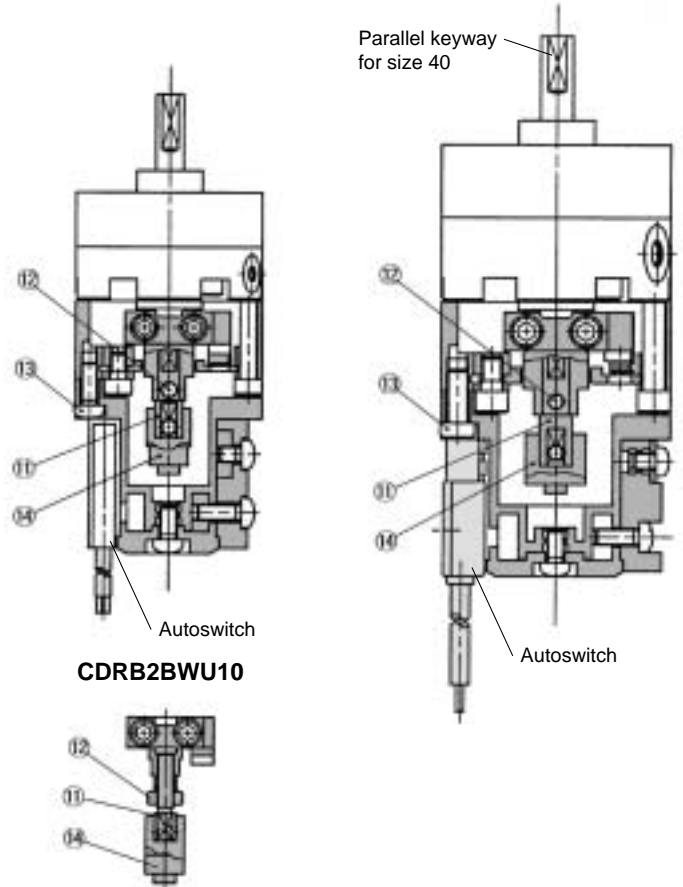

Parts list

No.	Description	Material	Note
1	Stopper ring	Die-cast aluminum	
2	Stopper lever	Carbon steel	
3	Lever retainer	Carbon steel	Zinc chromated
4	Rubber bumper	NBR	
5	Stopper block	Carbon steel	Zinc chromated
6	Block retainer	Carbon steel	Zinc chromated
7	Cap	Resin	
8	Hexagon socket head cap screw	Stainless steel	Special screw
9	Hexagon socket head cap screw	Stainless steel	Special screw
10	Hexagon socket head cap screw	Stainless steel	Special screw
11	Joint	Aluminum alloy	See note below.
12	Hexagon socket head set screw	Stainless steel	Hexagon nut will be used for size 10 only.
	Hexagon nut	Stainless steel	
13	Round head Phillips screw	Stainless steel	See note below.
14	Magnet lever	—	See note below.

Note) These items (No. 11, 13, and 14) consist of auto switch unit and angle adjuster. Refer to pages 84 and 85 for detailed specifications.

⚠ Specific Product Precautions

Be sure to read before handling.
Refer to pages 104 through 110 for safety precautions, actuator precautions, and auto switch precautions.

Angle Adjuster

⚠ Caution

1. Since the maximum angle of the rotation adjustment range will be limited by the rotation of the rotary actuator itself, make sure to take this into consideration when ordering.

Rotation of the rotary actuator	Rotation adjustment range
270° ⁺⁴ ₀	0° to 230° (Sizes: 10, 40)*
	0° to 240° (Sizes: 15, 20, 30)
180° ⁺⁴ ₀	0° to 175°
90° ⁺⁴ ₀	0° to 85°

* The maximum adjustment angle of the angle adjuster for size 10 and 40 is 230°.

2. Connecting ports are side ports only.
3. The allowable kinetic energy is the same as the specifications of the rotary actuator by itself (i.e., without angle adjuster).
4. Use a 100° rotary actuator if you desire to adjust the angle to 90° using a double vane type.

CRB2

Free-Mounting Type
CRBU2

CRB1

Series CRB2BWU

Dimensions: 10, 15, 20, 30 (with Angle Adjuster)

Single vane type

CRB2BWU10, 15, 20, 30-□S • Following illustrations show actuator for 90° when A port is pressurized.

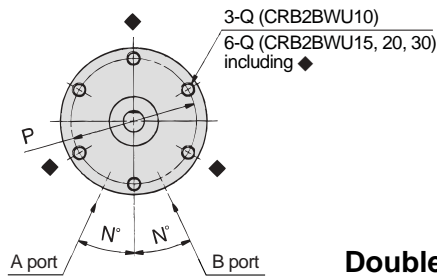
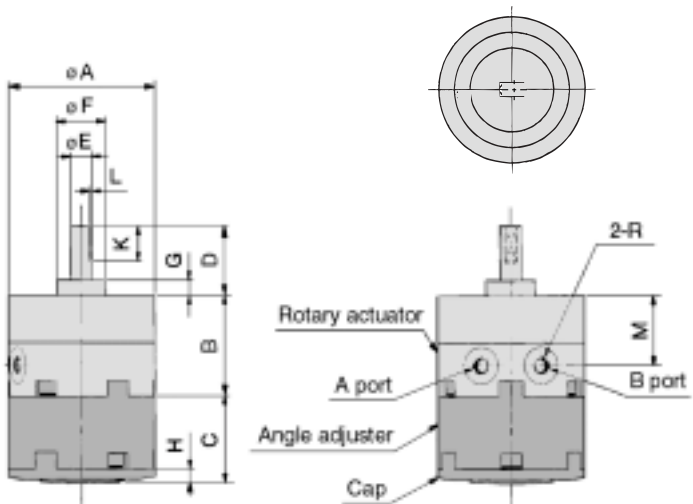

Double vane type

CRB2BWU10-□D • Following illustrations show the intermediate rotation position when A or B port is pressurized.

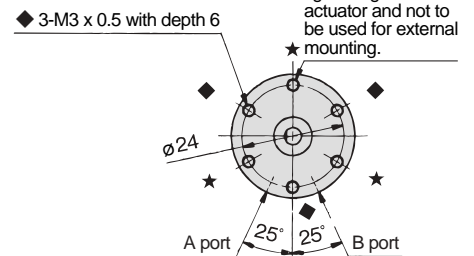
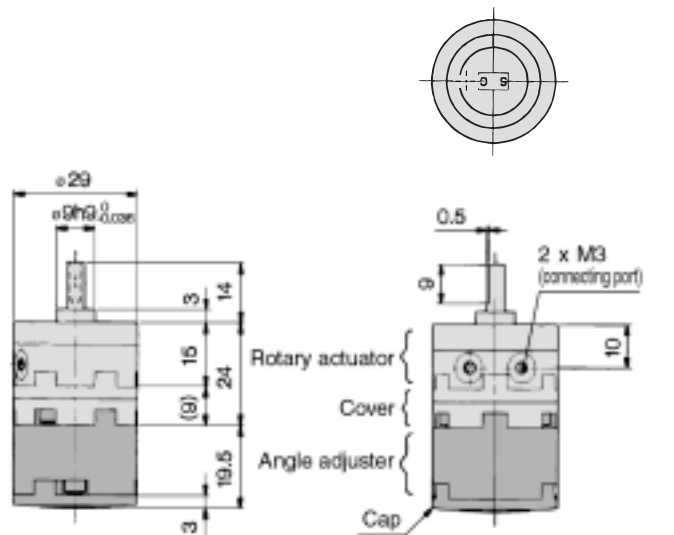

Double vane type CRB2BWU15, 20, 30-□D

Dimensions for double vane type sizes 15, 20, and 30 are the same as those of single type.

Model	A	B	C	D	E (g6)	F (h9)	G	H	K	L	M	N	P	Q
CRB2BWU10-□S	29	15	19.5	14	4	9	3	3	9	0.5	10	25	24	M3 depth 6
CRB2BWU15-□S	34	20	21.2	18	5	12	4	3.2	10	0.5	15	25	29	M3 depth 5
CRB2BWU15-□D														
CRB2BWU20-□S	42	29	25	20	6	14	4.5	4	10	0.5	20	25	36	M4 depth 7
CRB2BWU20-□D														
CRB2BWU30-□S	50	40	29	22	8	16	5	4.5	12	1	30	25	43	M5 depth 10
CRB2BWU30-□D														

Model	R			
	90°	100°	180°	270°
CRB2BWU10-□S	M5	—	M5	M3
CRB2BWU10-□D	M3		—	
CRB2BWU15-□S	M5	—	M5	M3
CRB2BWU15-□D	M3		—	
CRB2BWU20-□S	M5	—	M5	
CRB2BWU20-□D	M5		—	
CRB2BWU30-□S	M5	—	M5	
CRB2BWU30-□D	M5		—	

Dimensions: 40 (with Angle Adjuster)

Single vane/Double vane type
CRB2BWU40-□□S, D

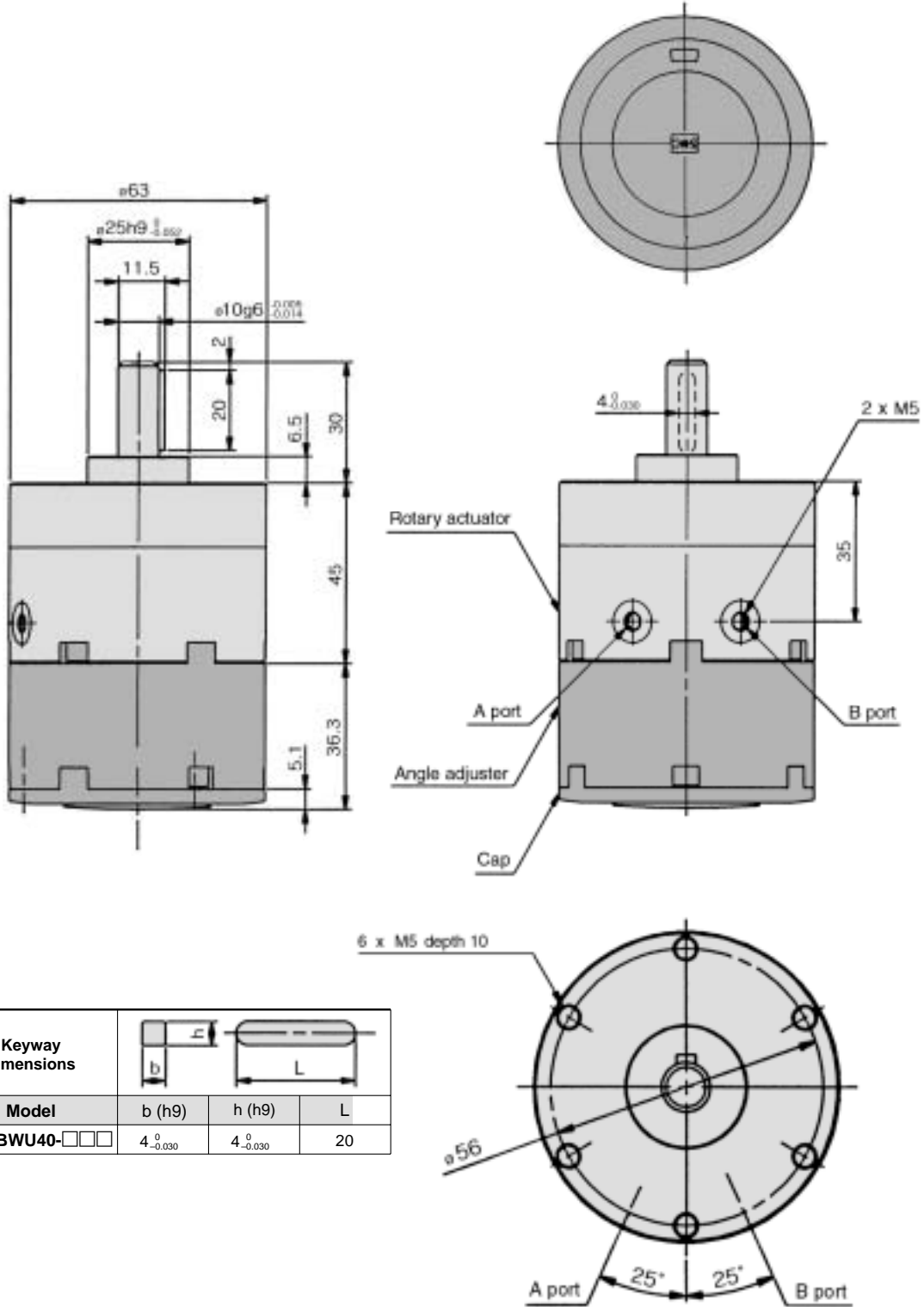

Keyway dimensions			
Model	b (h9)	h (h9)	L
CRB2BWU40-□□□	$4 \begin{smallmatrix} 0 \\ -0.030 \end{smallmatrix}$	$4 \begin{smallmatrix} 0 \\ -0.030 \end{smallmatrix}$	20

CRB2

Free-Mounting Type
CRBU2

CRB1

Series CDRB2BWU

Dimensions: 10, 15, 20, 30 (with Angle Adjuster and Auto Switch Unit)

Single vane type CDRB2BWU10, 15-□S

- Following illustrations show actuator for 90° when A port is pressurized.

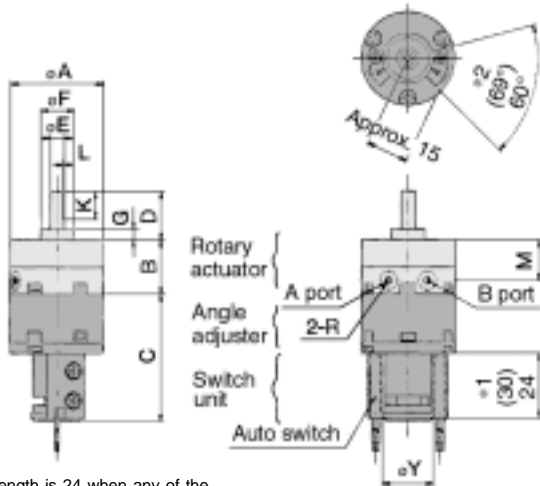

- *1. The length is 24 when any of the following auto switches are used: D-90, D90A, D-S99(V), D-T99(V), and D-S9P(V). The length is 30 when any of the following auto switches are used: D-97 and D-93A.
- *2. The angle is 60° when any of the following auto switches are used: D-90, D-90A, D-97, and D-93A. The angle is 69° when any of the following auto switches are used: D-S99(V), D-T99(V), and D-S9P(V).



Double vane type CDRB2BWU10-□D

- Following illustrations show the intermediate rotation position when A or B port is pressurized.

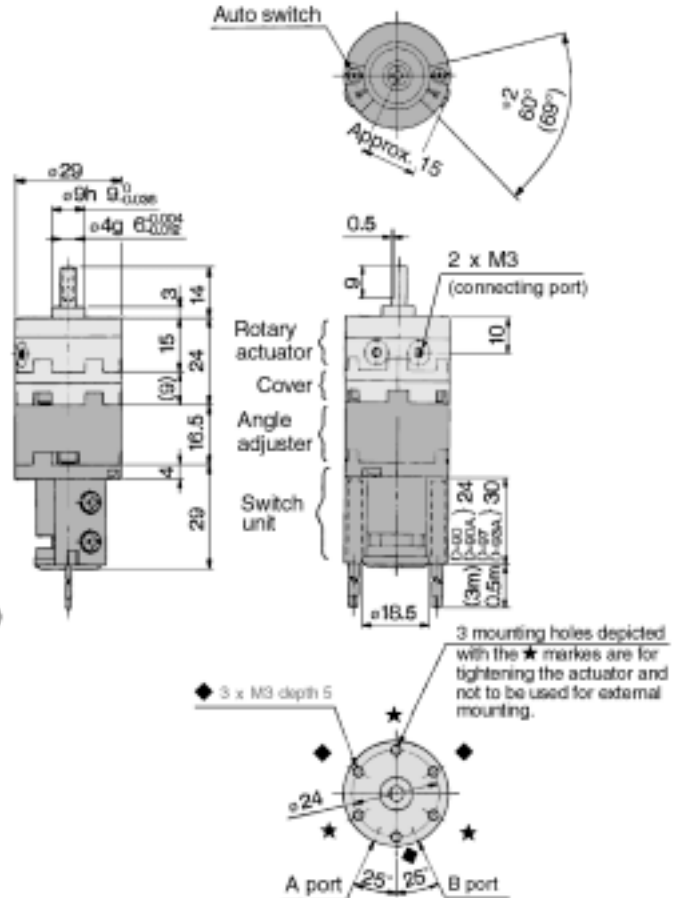

Single vane type CDRB2BWU20, 30-□S

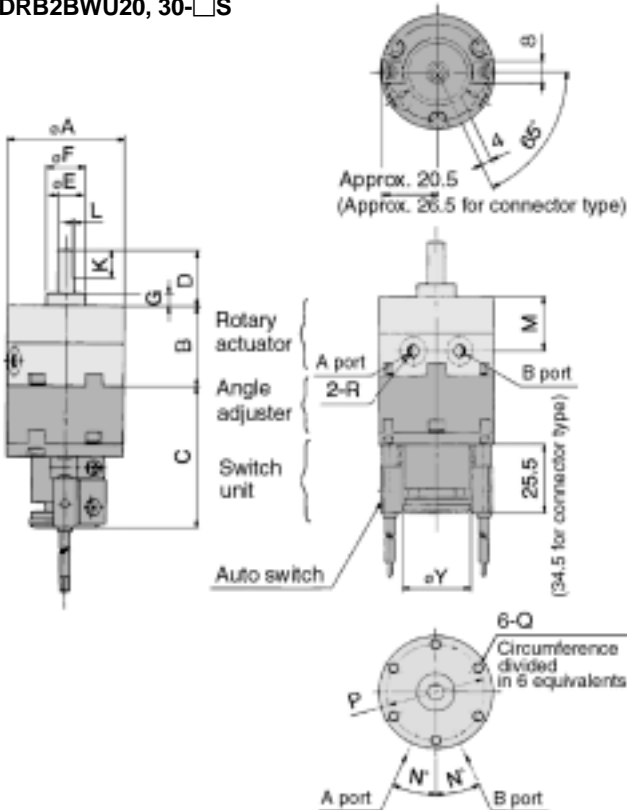

Double vane type CDRB2BWU15, 20, 30-□D

Dimensions for double vane type sizes 15, 20, and 30 are the same as those of single type.

Model	A	B	C	D	E (g6)	F (h9)	G	K	L	M
CDRB2BWU10-□S	29	15	45.5	14	4	9	3	9	0.5	10
CDRB2BWU15-□S CDRB2BWU15-□D	34	20	47	18	5	12	4	10	0.5	15
CDRB2BWU20-□S CDRB2BWU20-□D	42	29	51	20	6	14	4.5	10	0.5	20
CDRB2BWU30-□S CDRB2BWU30-□D	50	40	55.5	22	8	16	5	12	1	30

Model	N	P	Y	Q	R			
					90°	100°	180°	270°
CDRB2BWU10-□S	25	24	18.5	M3 depth 5	M5	—	M5	M3
CDRB2BWU10-□D					M3			
CDRB2BWU15-□S	25	29	18.5	M3 depth 5	M5	—	M5	M3
CDRB2BWU15-□D					M3			
CDRB2BWU20-□S	25	36	25	M4 depth 7	M5	—	M5	—
CDRB2BWU20-□D					M5			
CDRB2BWU30-□S	25	43	25	M5 depth 10	M5	—	M5	—
CDRB2BWU30-□D					M5			

- Notes) • For rotary actuators with angle adjuster and auto switch unit, connecting ports are side ports only.
- The above exterior view drawings illustrate the rotary actuator equipped with one right-hand and one left-hand switches.

Dimensions: 40 (with Angle Adjuster and Auto Switch Unit)

Single vane/Double vane type

CDRB2BWU40-□S, D

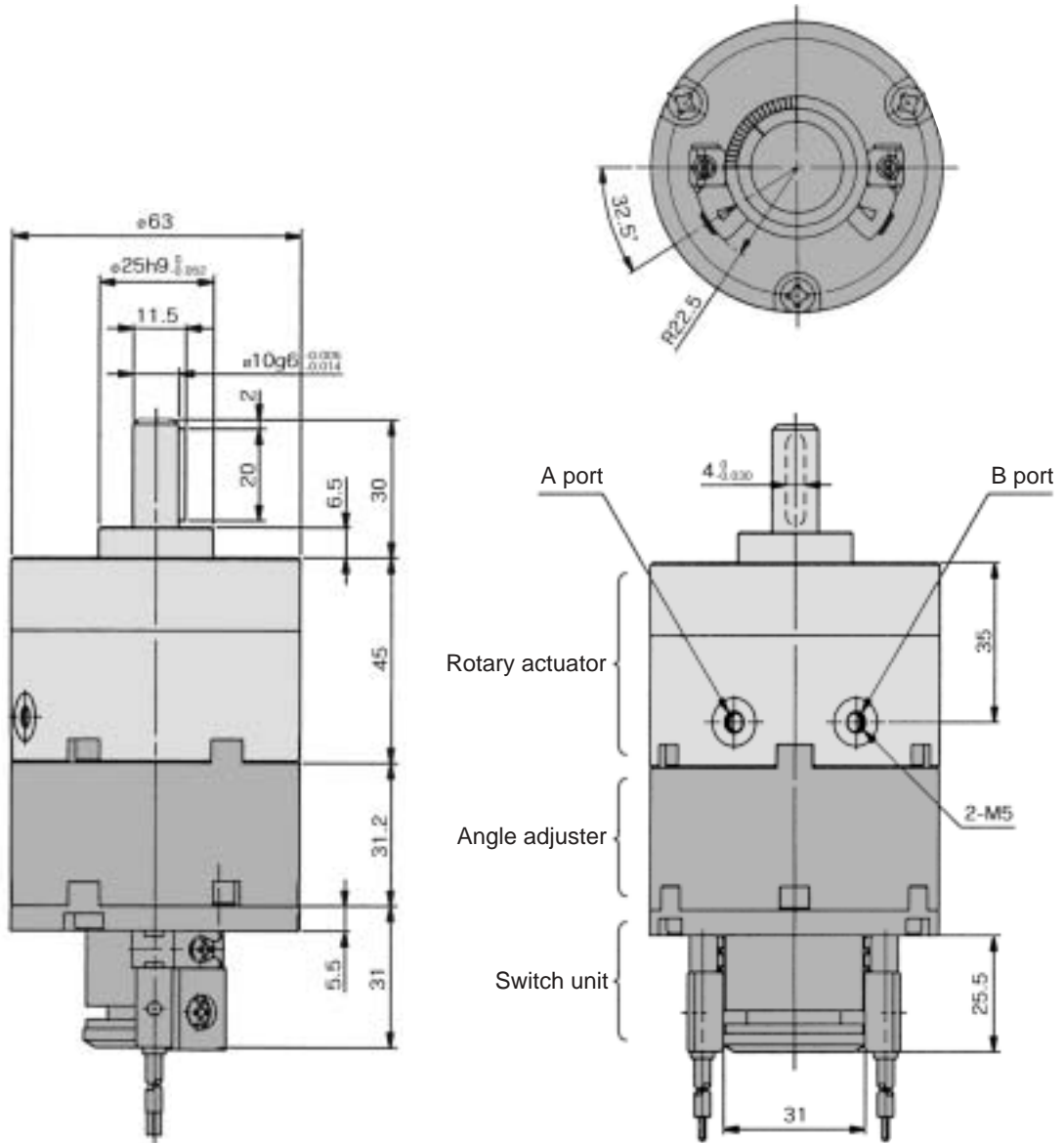

Keyway dimensions			
	b (h9)	h (h9)	L
Model	$4_{-0.030}^0$	$4_{-0.030}^0$	20

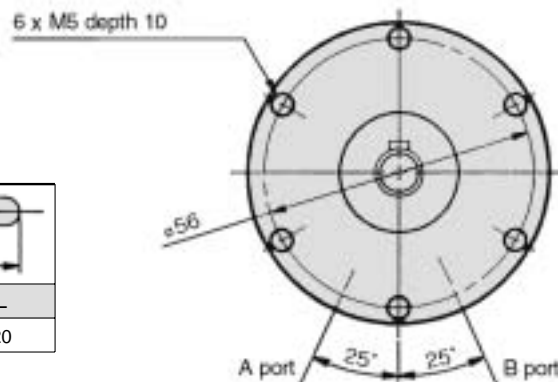

CRB2

Free-Mounting Type
CRBU2

CRB1

Series CRB2 (Sizes: 10, 15, 20, 30, 40)

Simple Specials

-XA1 to -XA24: Shaft Pattern Sequencing 1

Simple Specials System (a system for Made to Order) will be used for Shaft Pattern Sequencing (for ordering). (Refer to Features 3.) Please contact SMC for a specification sheet when placing an order.

Shaft Pattern Sequencing 1

-XA1 to XA24

Applicable shaft type: W (Standard)

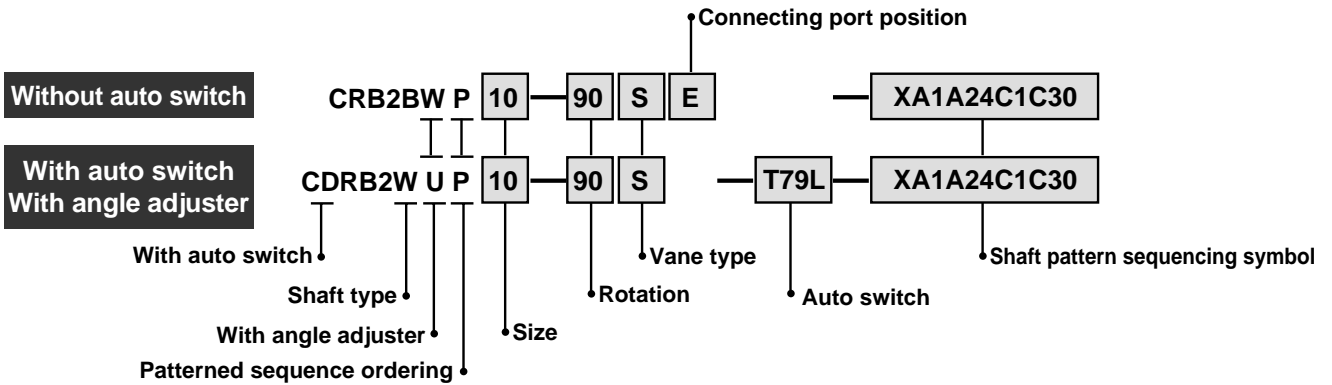

Shaft Pattern Sequencing Symbols

• Axial: Top (long-shaft side)

Symbol	Description	Applicable sizes				
		10	15	20	30	40
XA1	Shaft-end female threads		●	●	●	
XA3	Shaft-end male threads	●	●	●	●	
XA5	Stepped round shaft	●	●	●	●	
XA7	Stepped round shaft with female threads	●	●	●	●	
XA9	Modified length of standard chamfer	●	●	●	●	
XA11	Double-sided chamfer	●				
XA14*	Shaft through hole + Shaft-end female threads		●	●	●	●
XA17	Shortened shaft	●	●	●	●	
XA21	Round shaft with steps and double-sided chamfer	●	●	●	●	
XA23	Right-angle chamfer	●	●	●	●	
XA24	Double key					●

* This pattern is not available for rotary actuators with auto switch unit and/or angle adjuster.

• Axial: Bottom (short-shaft side)

Symbol	Description	Applicable sizes				
		10	15	20	30	40
XA2*	Shaft-end female threads		●	●	●	●
XA4*	Shaft-end male threads	●	●	●	●	●
XA6*	Stepped round shaft	●	●	●	●	●
XA8*	Stepped round shaft with female threads	●	●	●	●	●
XA10*	Modified length of standard chamfer	●	●	●	●	●
XA12*	Two-sided chamfer	●	●	●	●	●
XA15*	Shaft through hole + Shaft-end female thread		●	●	●	●
XA18*	Shortened shaft	●	●	●	●	●
XA22*	Stepped round shaft with double-sided chamfer	●	●	●	●	●

• Double shaft

Symbol	Description	Applicable sizes				
		10	15	20	30	40
XA13*	Shaft through hole		●	●	●	●
XA16*	Shaft through hole + Double shaft-end female threads		●	●	●	●
XA19	Shortened shaft	●	●	●	●	
XA20	Reversed shaft	●	●	●	●	●

Combinations

XA□ combinations

Symbol	Combination																								
XA1	XA1																								
XA2	●	XA2																							
XA3	—	●	XA3																						
XA4	●	—	●	XA4																					
XA5	—	●	—	●	XA5																				
XA6	●	—	●	—	●	XA6																			
XA7	—	●	—	●	—	●	XA7																		
XA8	●	—	●	—	●	—	●	XA8																	
XA9	—	●	—	●	—	●	—	●	XA9																
XA10	●	—	●	—	●	—	●	—	●	XA10															
XA11	—	●	—	●	—	●	—	●	—	●	XA11														
XA12	●	—	●	—	●	—	●	—	●	—	●	XA12													
XA13	—	—	—	—	—	—	—	—	—	—	—	●	●	—	—	—	—	—	—	—	—	—	—	—	—
XA14	—	—	—	—	—	—	—	—	—	—	—	—	●	●	—	—	—	—	—	—	—	—	—	—	—
XA15	—	—	—	—	—	—	—	—	—	—	—	—	—	●	●	—	—	—	—	—	—	—	—	—	—
XA16	—	—	—	—	—	—	—	—	—	—	—	—	—	—	—	—	—	—	—	—	—	—	—	—	—
XA17	—	●	—	●	—	●	—	●	—	●	—	●	—	●	—	●	—	●	—	●	—	●	—	●	—
XA18	●	—	●	—	●	—	●	—	●	—	●	—	●	—	●	—	●	—	●	—	●	—	●	—	●
XA19	—	—	—	—	—	—	—	—	—	—	—	—	—	—	—	—	—	—	—	—	—	—	—	—	—
XA20	—	—	—	—	—	—	—	—	—	—	—	—	—	—	—	—	—	—	—	—	—	—	—	—	—
XA21	—	●	—	●	—	●	—	●	—	●	—	●	—	●	—	●	—	●	—	●	—	●	—	●	—
XA22	●	—	●	—	●	—	●	—	●	—	●	—	●	—	●	—	●	—	●	—	●	—	●	—	●
XA23	—	●	—	●	—	●	—	●	—	●	—	●	—	●	—	●	—	●	—	●	—	●	—	●	—
XA24	—	●	—	●	—	●	—	●	—	●	—	●	—	●	—	●	—	●	—	●	—	●	—	●	—

Combination

●	Available
—	Not available

A combination of up to two XA□s are available.
Example: -XA1A2

XA□, XC□ combinations

Combination other than -XA□, such as Made to Order (-XC□), is also available.
Refer to pages 31 and 32 for detailed description of Made to Order.

Symbol	Description	Applicable sizes	Combination
			XA1 to XA24
XC1*	Add connecting port	10, 15, 20, 30, 40	●
XC2*	Change threads to through hole	15, 20, 30, 40	●
XC3*	Change a screw position	10, 15, 20, 30, 40	●
XC4	Change rotation range		●
XC5	Change rotation range between 0° to 200°		●
XC6	Change rotation range between 0° to 110°		●
XC7*	Reversed shaft		—
XC30	Fluorine grease		●

 * These specifications are not available for rotary actuators with auto switch unit and angle adjuster.
A total of four XA□ and XC□ combinations is available.
Examples: -XA1A2C1C30
 -XA2C1C4C30

CRB2

Free-Mounting Type
CRBU2

CRB1

Axial: Top (Long-shaft side)

Symbol: A1 The long shaft can be further shortened by machining female threads into it. (If shortening the shaft is not required, indicate "*" for dimension X.)

- Not available for size 10.
- The maximum dimension L1 is, as a rule, twice the thread size. (Example) For M3: L1 = 6mm
- Applicable shaft type: W

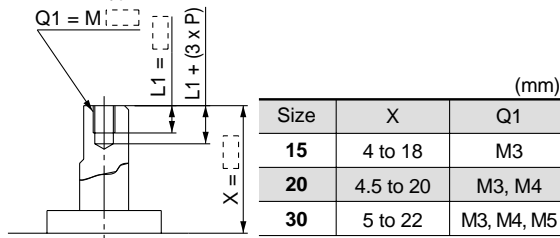

Symbol: A3 The long shaft can be further shortened by machining male threads into it. (If shortening the shaft is not required, indicate "*" for dimension X.)

- Applicable shaft type: W

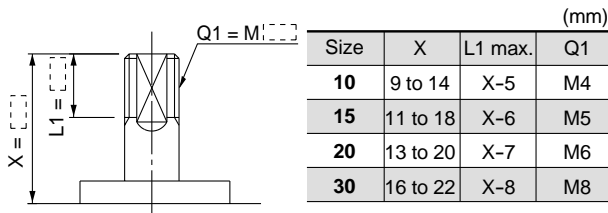

Symbol: A5 The long shaft can be further shortened by machining it into a stepped round shaft. (If shortening the shaft is not required, indicate "*" for dimension X.)

- Applicable shaft type: W
- Equal dimensions are indicated by the same marker. (If not specifying dimension C1, indicate "*" instead.)

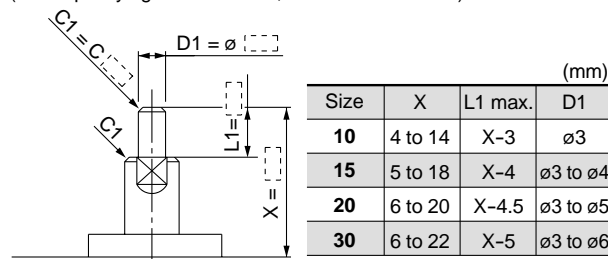

Symbol: A7 The long shaft can be further shortened by machining it into a stepped round shaft with male threads. (If shortening the shaft is not required, indicate "*" for dimension X.)

- Applicable shaft type: W
- Equal dimensions are indicated by the same marker. (If not specifying dimension C1, indicate "*" instead.)

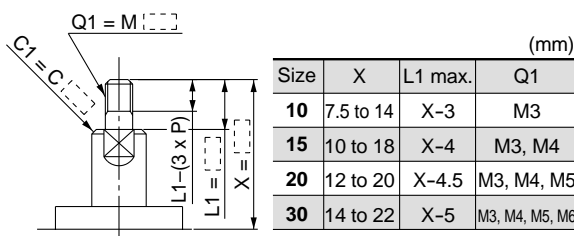

Axial: Bottom (Short-shaft side)

Symbol: A2 The short shaft can be further shortened by machining female threads into it. (If shortening the shaft is not required, indicate "*" for dimension Y.)

- Not available for size 10.
- The maximum dimension L2 is, as a rule, twice the thread size. (Example) For M3: L2 = 6mm
- Applicable shaft type: W

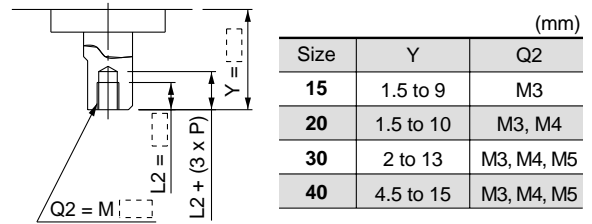

Symbol: A4 The short shaft can be further shortened by machining male threads into it. (If shortening the shaft is not required, indicate "*" for dimension Y.)

- Applicable shaft type: W

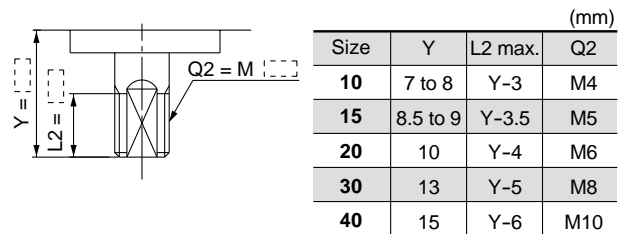

Symbol: A6 The short shaft can be further shortened by machining it into a stepped round shaft. (If shortening the shaft is not required, indicate "*" for dimension Y.)

- Applicable shaft type: W
- Equal dimensions are indicated by the same marker. (If not specifying dimension C2, indicate "*" instead.)

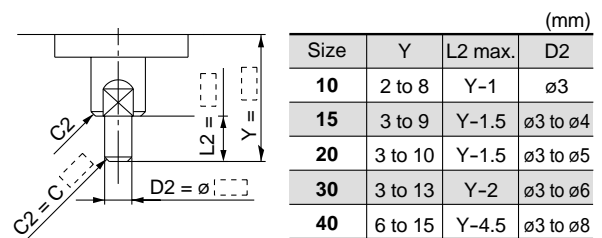

Symbol: A8 The short shaft can be further shortened by machining it into a stepped round shaft with male threads. (If shortening the shaft is not required, indicate "*" for dimension Y.)

- Applicable shaft type: W
- Equal dimensions are indicated by the same marker. (If not specifying dimension C2, indicate "*" instead.)

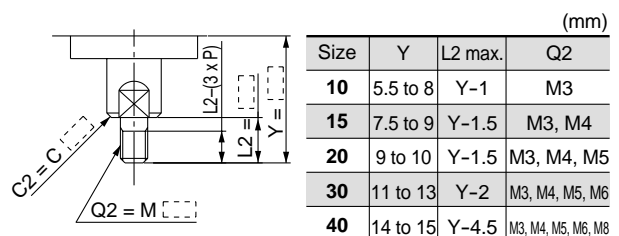

Axial: Top (Long-shaft side)

Symbol: A9 The long shaft can be further shortened by changing the length of the standard chamfer on the long shaft side. (If shortening the shaft is not required, indicate "*" for dimension X.)

- Applicable shaft type: W

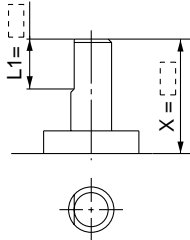

Size	X	L1
10	5 to 14	9-(14-X) to (X-3)
15	8 to 18	10-(18-X) to (X-4)
20	10 to 20	10-(20-X) to (X-4.5)
30	10 to 22	12-(22-X) to (X-5)

Symbol: A11 The long shaft can be further shortened by machining a double-sided chamfer onto it. (If altering the standard chamfer and shortening the shaft are not required, indicate "*" for both the L1 and X dimensions.)

- Since L1 is a standard chamfer, dimension E1 is 0.5mm or more, and 1mm or more with a shaft bore size of $\phi 30$.
- Applicable shaft type: W

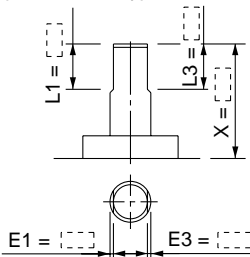

Size	X	L1	L3 max.
10	5 to 14	9-(14-X) to (X-3)	X-3
15	8 to 18	10-(18-X) to (X-4)	X-4
20	10 to 20	10-(20-X) to (X-4.5)	X-4.5
30	10 to 22	12-(22-X) to (X-5)	X-5

Symbol: A14 Applicable to single vane type only
A special end is machined onto the long shaft, and a through hole is drilled into it. Female threads are machined into the through hole, whose diameter is equivalent to the pilot hole diameter.

- Not available for size 10.
- The maximum L1 dimension is, as a rule, twice the thread size. (Example) For M3: L1 = 6mm
- A parallel keyway is used on the long shaft for size 40.
- Applicable shaft type: W

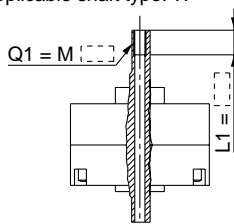

Thread	Size 15	20	30	40
M3	$\phi 2.5$	$\phi 2.5$	$\phi 2.5$	$\phi 2.5$
M4	—	$\phi 3.3$	$\phi 3.3$	—
M5	—	—	$\phi 4.2$	—

Symbol: A17 Shorten the long shaft.

- Applicable shaft type: W

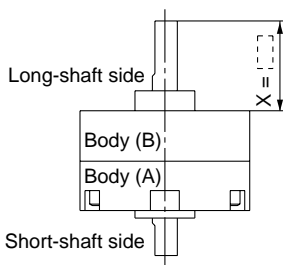

Size	X
10	3 to 14
15	4 to 18
20	4.5 to 20
30	5 to 22

Axial: Bottom (Short-shaft side)

Symbol: A10 The short shaft can be further shortened by changing the length of the standard chamfer. (If shortening the shaft is not required, indicate "*" for dimension Y.)

- Applicable shaft type: W

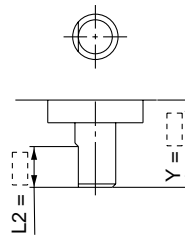

Size	Y	L2
10	3 to 8	5-(8-Y) to (Y-1)
15	3 to 9	6-(9-Y) to (Y-1.5)
20	3 to 10	7-(10-Y) to (Y-1.5)
30	5 to 13	8-(13-Y) to (Y-2)
40	7 to 15	9-(15-Y) to (Y-2)

Symbol: A12 The short shaft can be further shortened by machining a double-sided chamfer onto it. (If altering the standard chamfer and shortening the shaft are not required, indicate "*" for both the L2 and Y dimensions.)

- Since L2 is a standard chamfer, dimension E2 is 0.5mm or more, and 1mm or more with shaft bore sizes of $\phi 30$ or $\phi 40$.
- Applicable shaft type: W

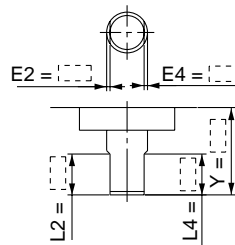

Size	Y	L2	L4 max.
10	3 to 8	5-(8-Y) to (Y-1)	Y-1
15	3 to 9	6-(9-Y) to (Y-1.5)	Y-1.5
20	3 to 10	7-(10-Y) to (Y-1.5)	Y-1.5
30	5 to 13	8-(13-Y) to (Y-2)	Y-2
40	7 to 15	9-(15-Y) to (Y-2)	Y-2

Symbol: A15 Applicable to single vane type only
A special end is machined onto the short shaft, and a through hole is drilled into it. Female threads are machined into the through hole, whose diameter is equivalent to the pilot hole diameter.

- Not available for size 10.
- The maximum L2 dimension is, as a rule, twice the thread size. (Example) For M4: L2 = 8mm
- A parallel keyway is used on the long shaft for size 40.
- Applicable shaft type: W

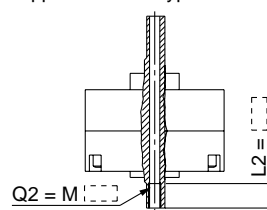

Thread	Size 15	20	30	40
M3	$\phi 2.5$	$\phi 2.5$	$\phi 2.5$	$\phi 2.5$
M4	—	$\phi 3.3$	$\phi 3.3$	—
M5	—	—	$\phi 4.2$	—

Symbol: A18 Shorten the short shaft.

- A parallel keyway is used on the long shaft for size 40.
- Applicable shaft type: W

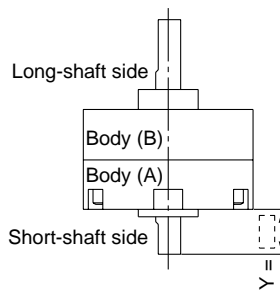

Size	Y
10	1 to 8
15	1.5 to 9
20	1.5 to 10
30	2 to 13
40	4.5 to 15

Series CRB2

Axial: Top (Long-shaft side)

Symbol: A21 The long shaft can be further shortened by machining it into a stepped round shaft with a double-sided chamfer. (If shortening the shaft is not required, indicate "*" for dimension X.)

- Applicable shaft type: W
- Equal dimensions are indicated by the same marker. (If not specifying dimension C1, indicate "*" instead.)

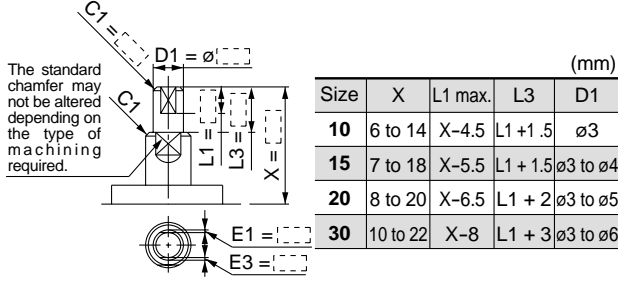

Axial: Bottom (Short-shaft side)

Symbol: A22 The short shaft can be further shortened by machining it into a stepped round shaft with a double-sided chamfer. (If shortening the shaft is not required, indicate "*" for dimension Y.)

- Applicable shaft type: W
- Equal dimensions are indicated by the same marker. (If not specifying dimension C2, indicate "*" instead.)

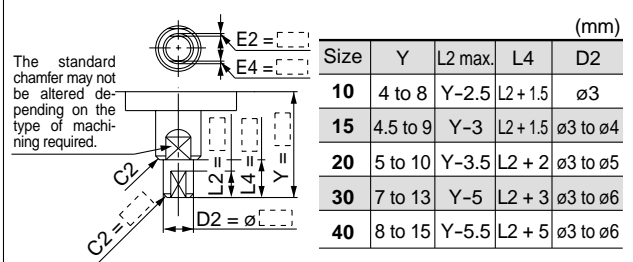

Double shaft

Symbol: A13 Applicable to single vane type only

- Shaft with through hole
- Not available for size 10.
 - Minimum machining diameter for d1 is 0.1mm.
 - A parallel keyway is used on the long shaft for size 40.
 - Applicable shaft type: W

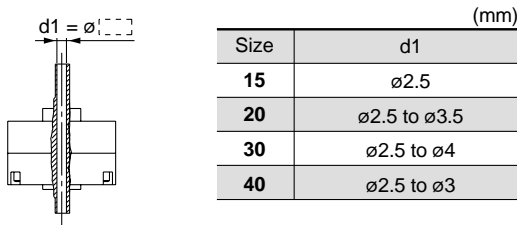

Symbol: A16 Applicable to single vane type only

A special end is machined onto both the long and short shafts, and a through hole is drilled into both shafts. Female threads are machined into the through holes, whose diameter is equivalent to the diameter of the pilot holes.

- Not available for size 10.
- The maximum L1 dimension is, as a rule, twice the thread size. (Example) For M5: L1 = 10mm (max.)
- A parallel keyway is used on the long shaft for size 40.
- Applicable shaft type: W
- Equal dimensions are indicated by the same marker.

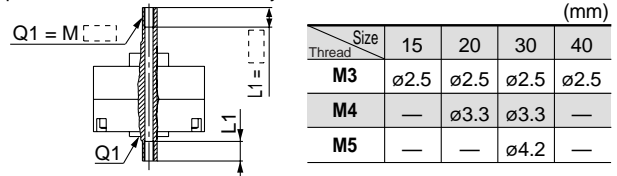

Symbol: A19 Both the long shaft and short shaft are shortened.

- A parallel keyway is used on the long shaft for size 40.
- Applicable shaft type: W

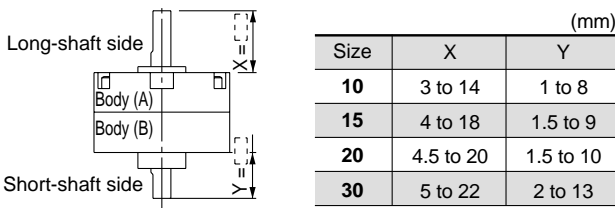

Symbol: A20 The rotation axis is reversed. (The long shaft and short shaft are shortened.)

- A parallel keyway is used on the long shaft for size 40.
- Applicable shaft type: W

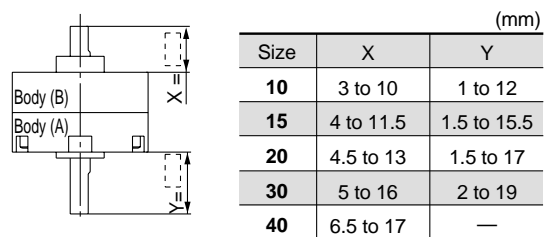

Symbol: A23 The long shaft can be further shortened by machining right-angle double-sided chamfer onto it. (If altering the standard chamfer and shortening the shaft are not required, indicate "*" for both the L1 and X dimensions.)

- Since L1 is a standard chamfer, dimension E1 is 0.5mm or more, and 1mm or more with a shaft bore sizes of ø30 or ø40.
- Applicable shaft type: W

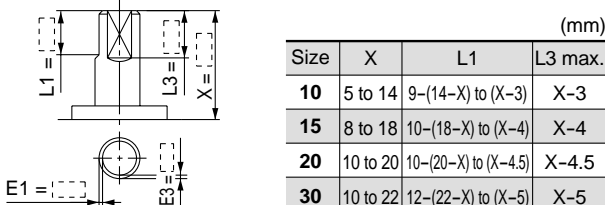

Symbol: A24 Double key

Keys and keyways are machined at 180° from the standard position.

- Applicable shaft type: W
- Equal dimensions are indicated by the same marker.

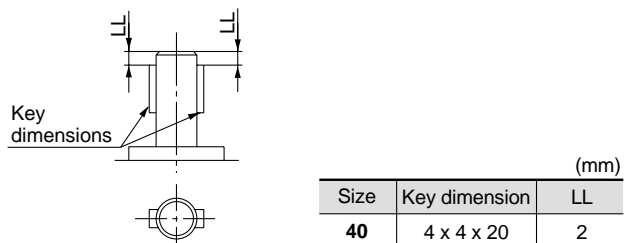

CRB2

Free-Mounting Type
CRBU2

CRB1

Series CRB2 (Sizes: 10, 15, 20, 30, 40)

Simple Specials

-XA31 to -XA47: Shaft Pattern Sequencing 2

Simple Specials System (a system for Made to Order) will be used for Shaft Pattern Sequencing (for ordering). (Refer to Features 3.) Please contact SMC for a specification sheet when placing an order.

Shaft Pattern Sequencing 2

-XA31 to XA47

Applicable shaft types: J, K, S, T, Y

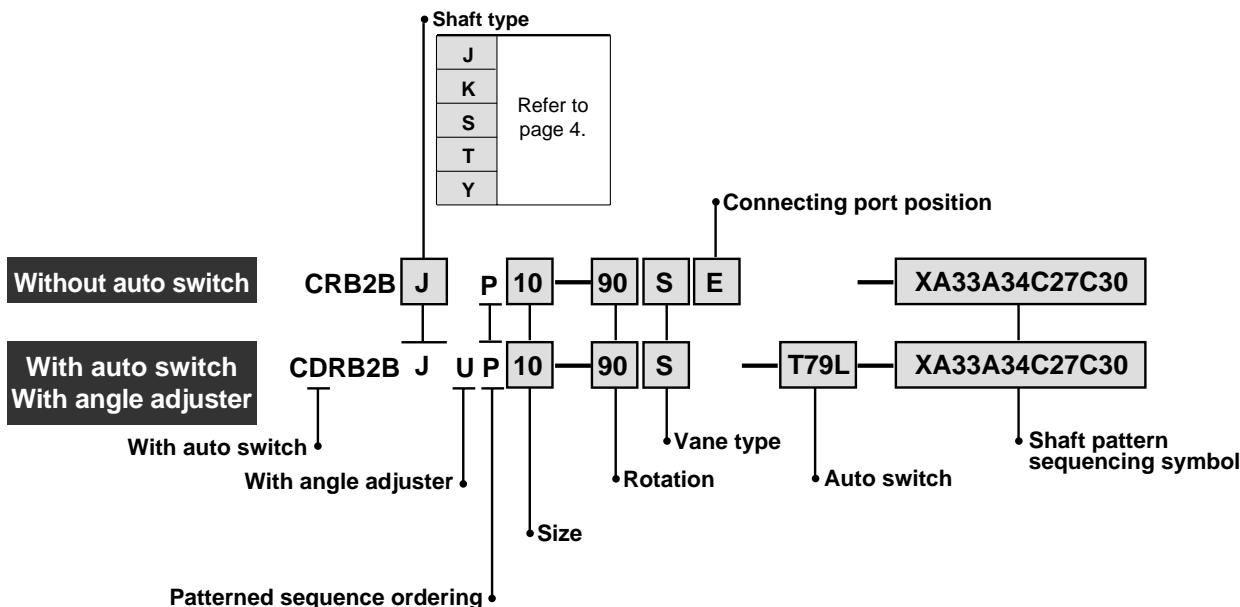

Shaft Pattern Sequencing Symbols

• Axial: Top (long-shaft side)

Symbol	Description	Shaft types	Applicable sizes				
			10	15	20	30	40
XA31	Shaft-end female threads	S, Y	●	●	●	●	●
XA33	Shaft-end female threads	J, K, T	●	●	●	●	●
XA37	Stepped round shaft	J, K, T	●	●	●	●	●
XA45	Middle-cut chamfer	J, K, T	●	●	●	●	●
XA47	Machined keyway	J, K, T			●	●	

• Axial: Bottom (short-shaft side)

Symbol	Description	Shaft types	Applicable sizes				
			10	15	20	30	40
XA32*	Shaft-end female threads	S, Y		●	●	●	●
XA34*	Shaft-end female threads	J, K, T		●	●	●	●
XA38*	Stepped round shaft	K	●	●	●	●	●
XA46*	Middle-cut chamfer	K	●	●	●	●	●

• Double shaft

Symbol	Description	Shaft types	Applicable sizes				
			10	15	20	30	40
XA39*	Shaft through hole	S, Y		●	●	●	●
XA40*	Shaft through hole	K, T		●	●	●	●
XA41*	Shaft through hole	J		●	●	●	●
XA42*	Shaft through hole + Shaft-end female threads	S, Y		●	●	●	●
XA43*	Shaft through hole + Shaft-end female threads	K, T		●	●	●	●
XA44*	Shaft through hole + Shaft-end female threads	J		●	●	●	●



* These specifications are not available for rotary actuators with auto switch unit and/or angle adjuster.

Combinations

XA□ combinations

Symbol	Combination					
XA31	XA31					
XA32	SY	XA32				
XA33	—	JKT	XA33			
XA34	—	—	JKT	XA34		
XA37	—	—	—	JKT	XA37	
XA38	—	—	K	—	K	XA38

A combination of up to two XA□s are available.
Example: -XA31A32

XA□, XC□ combinations

Combination other than -XA□, such as Made to Order (-XC□), is also available. Refer to pages 31 and 32 for detailed description of Made to Order.

Symbol	Description	Applicable sizes	Combination XA31 to XA47
XC1*	Add connecting port	10, 15, 20, 30, 40	●
XC2*	Change threads to through hole	15, 20, 30, 40	●
XC3*	Change a screw position	10, 15, 20, 30, 40	●
XC4	Change rotation range		●
XC5	Change rotation range between 0° to 200°		●
XC6	Change rotation range between 0° to 110°		●
XC7*	Reversed shaft		—
XC30	Fluorine grease		●



* These specifications are not available for rotary actuators with auto switch unit and/or angle adjuster.
A total of four XA□ and XC□ combinations is available.
Example: -XA33A34C27C30

Axial: Top (Long-shaft side)

Symbol: A31 Machine female threads into the long shaft.

- The maximum dimension L1 is, as a rule, twice the thread size.
(Example) For M3: L1 = 6mm
- Applicable shaft types: S, Y

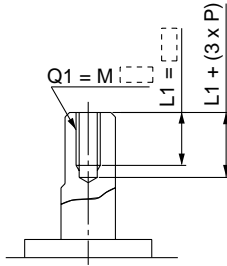

Size	Q1 (mm)	
	Shaft type	
10	S	Y
15	Not available	
20	M3	
30	M3, M4	

Symbol: A33 Machine female threads into the long shaft.

- The maximum dimension L1 is, as a rule, twice the thread size.
(Example) For M3: L1 = 6mm
- Applicable shaft types: J, K, T

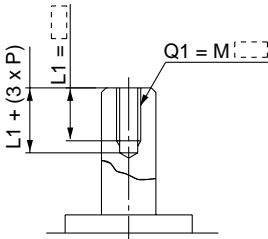

Size	Q1 (mm)		
	Shaft type	J	K
10	Not available		
15	M3		
20	M3, M4		
30	M3, M4, M5		
40	M3, M4, M5		

Symbol: A37 The long shaft can be further shortened by machining it into a stepped round shaft. (If shortening the shaft is not required, indicate "*" for dimension X.)

- Applicable shaft types: J, K, T
- Equal dimensions are indicated by the same marker.
(If not specifying dimension C1, indicate "*" instead.)

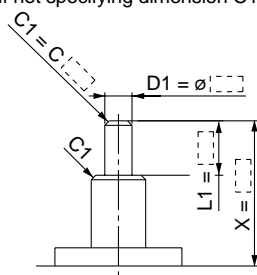

Size	X (mm)			D1
	X	L1 max.	D1	
10	4 to 14	X-3	ø3 to ø3.9	
15	5 to 18	X-4	ø3 to ø4.9	
20	6 to 20	X-4.5	ø3 to ø5.9	
30	6 to 22	X-5	ø3 to ø7.9	
40	8 to 30	X-6.5s	ø3 to ø9.9	

Symbol: A45 The long shaft can be further shortened by machining a middle-cut chamfer into it. (The position of the chamfer is same as the standard one.)
(If shortening the shaft is not required, indicate "*" for dimension X.)

- Applicable shaft types: J, K, T

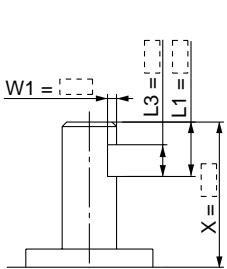

Size	X (mm)			W1			L1 max.			L3 max.		
	Shaft type	J	K	T	J	K	T	J	K	T	J	K
10	6.5 to 14			0.5 to 2			X-3			L1-1		
15	8 to 18			0.5 to 2.5			X-4			L1-1		
20	9 to 20			0.5 to 3			X-4.5			L1-1		
30	11.5 to 22			0.5 to 4			X-5			L1-2		
40	15.5 to 30			0.5 to 5			X-5.5			L1-2		

Axial: Bottom (Short-shaft side)

Symbol: A32 Machine female threads into the short shaft.

- The maximum dimension L2 is, as a rule, twice the thread size.
(Example) For M4: L2 = 8mm
However, for M5 with S shaft, the maximum dimension L2 is 1.5 times the thread size.
- Applicable shaft types: S, Y

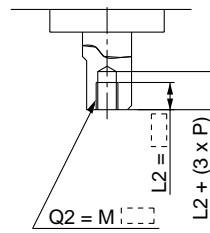

Size	Q2 (mm)	
	Shaft type	
10	S	Y
15	Not available	
20	M3	
30	M3, M4, M5	

Symbol: A34 Machine female threads into the short shaft.

- The maximum dimension L2 is, as a rule, twice the thread size.
(Example) For M3: L2 = 6mm
However, for M5 with T shaft, the maximum dimension L2 is 1.5 times the thread size.
- Applicable shaft types: J, K, T

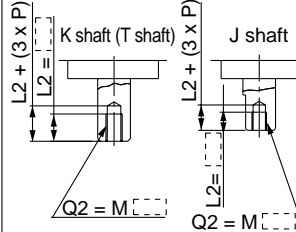

Size	Q2 (mm)		
	Shaft type	J	K
10	Not available		
15	M3		
20	M3, M4		
30	M3, M4, M5		
40	M3, M4, M5		

Symbol: A38 The short shaft can be further shortened by machining it into a stepped round shaft. (If shortening the shaft is not required, indicate "*" for dimension Y.)

- Applicable shaft type: K
- Equal dimensions are indicated by the same marker.
(If not specifying dimension C2, indicate "*" instead.)

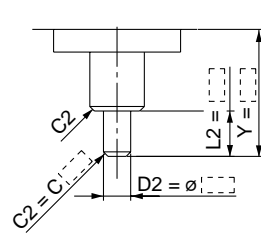

Size	Y (mm)			Q2
	Y	L2 max.	Q2	
10	2 to 14	Y-1	ø3 to ø3.9	
15	3 to 18	Y-1.5	ø3 to ø4.9	
20	3 to 20	Y-1.5	ø3 to ø5.9	
30	3 to 22	Y-2	ø3 to ø7.9	
40	6 to 30	Y-4.5	ø5 to ø9.9	

Symbol: A46 The short shaft can be further shortened by machining a middle-cut chamfer into it. (The position of the chamfer is same as the standard one.)
(If shortening the shaft is not required, indicate "*" for dimension Y.)

- Applicable shaft type: K

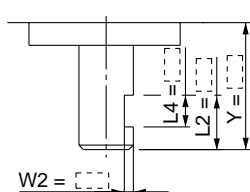

Size	Y (mm)			L4 max.	L2 max.	L4 max.
	Y	W2	L2 max.			
10	4.5 to 14	0.5 to 2	Y-1	L2-1	L4-1	L4-1
15	5.5 to 18	0.5 to 2.5	Y-1.5	L2-1	L4-1	L4-1
20	6 to 20	0.5 to 3	Y-1.5	L2-1	L4-1	L4-1
30	8.5 to 22	0.5 to 4	Y-2	L2-2	L4-2	L4-2
40	13.5 to 30	0.5 to 5	Y-4.5	L2-2	L4-2	L4-2

Series CRB2

Axial: Top (Long-shaft side)

Symbol: A47 Machine a keyway into the long shaft. (The position of the keyway is same as the standard one.)
The key must be ordered separately.

- Applicable shaft types: J, K, T

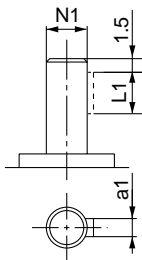

(mm)			
Size	a1	L1	N1
20	2h9 _{-0.025} ⁰	10	6.8
30	3h9 _{-0.025} ⁰	14	9.2

Double shaft

Symbol: A39 Applicable to single vane type only
Shaft with through hole (Additional machining of S, Y shaft)

- Not available for size 10.
- Minimum machining diameter for d1 is 0.1mm.
- A parallel keyway is used on the long shaft for size 40.
- Applicable shaft types: S, Y
- Equal dimensions are indicated by the same marker.

Shaft type		(mm)	
Size	S	Y	d1
15			ø2.5
20			ø2.5 to ø3.5
30			ø2.5 to ø4
40			ø2.5 to ø3

Symbol: A40 Applicable to single vane type only
Shaft with through hole (Additional machining of K, T shaft)

- Not available for size 10.
- d1 = ø2.5, L1 = 18 (max.) for size 15; minimum machining diameter for d1 is 0.1mm.
- d1 = d3 for sizes 20 to 40.
- Applicable shaft types: K, T

Shaft type		(mm)	
Size	K	T	d1
15			ø2.5 to ø3
20			ø2.5 to ø4
30			ø2.5 to ø4.5
40			ø2.5 to ø5

Symbol: A41 Applicable to single vane type only
Shaft with through hole

- Not available for size 10.
- Applicable shaft type: J
- Equal dimensions are indicated by the same marker.

(mm)	
Size	d1
15	ø2.5
20	ø2.5 to ø3.5
30	ø2.5 to ø4
40	ø2.5 to ø4.5

Symbol: A42 Applicable to single vane type only
A special end is machined onto both the long and short shafts, and a through hole is drilled into both. Female threads are machined into the through holes, whose diameter is equivalent to the diameter of the pilot holes.

- Not available for size 10.
- The maximum L1 dimension is, as a rule, twice the thread size. (Example) For M5: L1 = 10mm
- However, for M5 on the short shaft of S shaft: L1 = 7.5mm
- A parallel keyway is used on the long shaft for size 40.
- Applicable shaft types: S, Y
- Equal dimensions are indicated by the same marker.

Size		15		20		30		40		
Thread	Shaft type		S	Y	S	Y	S	Y	S	Y
	M3			ø2.5	ø2.5	ø2.5	ø2.5	ø2.5	ø2.5	—
M4			—	ø3.3	ø3.3	—	—	—	—	—
M5			—	—	ø4.2	—	—	—	—	—

Symbol: A43 Applicable to single vane type only
A special end is machined onto both the long and short shafts, and a through hole is drilled into both shafts. Female threads are machined into the through holes, whose diameter is equivalent to the diameter of the pilot holes.

- Not available for size 10.
- The maximum L1 dimension is, as a rule, twice the thread size. (Example) For M5: L1 = 10mm
- However, for M5 on the short shaft of T shaft: L1 = 7.5mm
- Applicable shaft types: K, T
- Equal dimensions are indicated by the same marker.

Size		15		20		30		40		
Thread	Shaft type		K	T	K	T	K	T	K	T
	M3			ø2.5	ø2.5	ø2.5	ø2.5	ø2.5	ø2.5	—
M4			—	ø3.3	ø3.3	—	—	—	—	—
M5			—	—	ø4.2	—	—	—	—	—

Symbol: A44 Applicable to single vane type only
A special end is machined onto both the long and short shafts, and a through hole is drilled into both shafts. Female threads are machined into the through holes, whose diameter is equivalent to the diameter of the pilot holes.

- Not available for size 10.
- The maximum L1 dimension is, as a rule, twice the thread size. (Example) For M5: L1 = 10mm
- A parallel keyway is used on the long shaft for size 40.
- Applicable shaft type: J
- Equal dimensions are indicated by the same marker.

Size		15		20		30		40	
Thread			15	20	30	40			
	M3			ø2.5	ø2.5	ø2.5	ø2.5		
M4			—	ø3.3	ø3.3	ø3.3			
M5			—	—	ø4.2	ø4.2			

Series CRB2 (Sizes: 10, 15, 20, 30, 40) Made to Order XC1, 2, 3, 4, 5, 6, 7, 30

XC1 to XC7, XC30

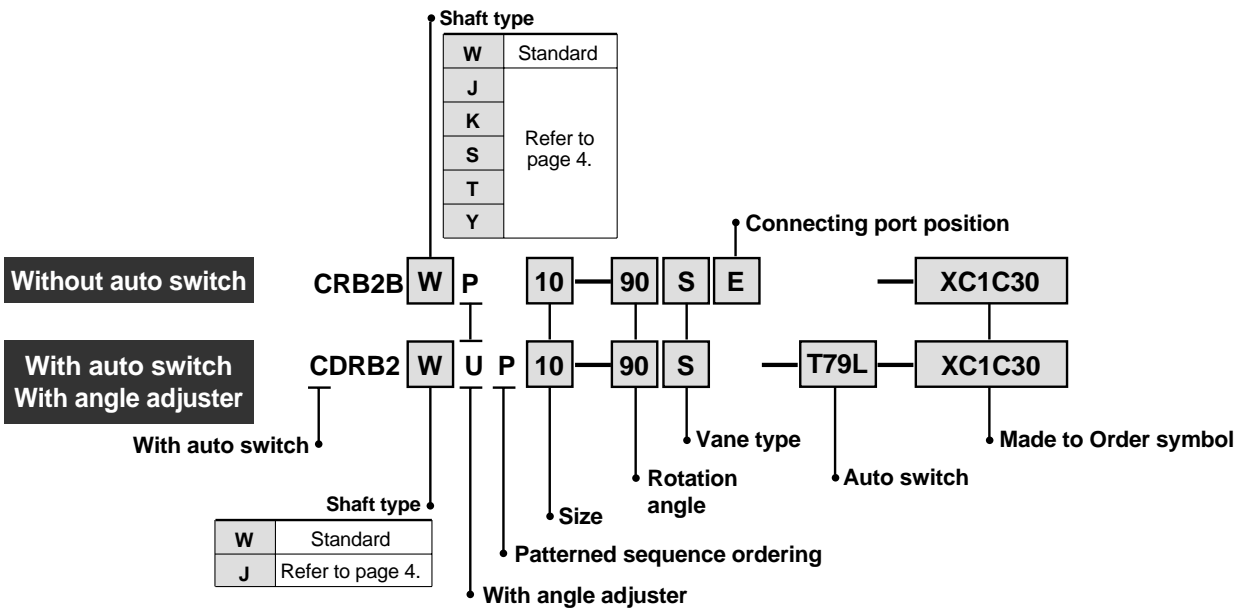

Made to Order Symbols

Symbol	Description	Applicable shaft types	Applicable sizes
		W, J, K, S, T, Y	
XC1*	Add connecting port	●	10,
XC2*	Change threaded holes to through holes	●	
XC3*	Change the screw position	●	
XC4	Change rotation range and direction	●	15,
XC5	Change rotation between 0° to 200° range and direction	●	20,
XC6	Change rotation between 0° to 110° range and direction	●	30,
XC7*	Reversed shaft	W, J	40
XC30	Fluorine grease	●	

* These specifications are not available for rotary actuators with auto switch unit and angle adjuster.

Combinations

Symbol	Combination						
XC1	XC1						
XC2	●	XC2					
XC3	●	—	XC3				
XC4	●	●	●	XC4			
XC5	●	●	●	—	XC5		
XC6	●	●	●	—	—	XC6	
XC7	●	●	●	●	●	—	XC7
XC30	●	●	●	●	●	●	●

Combination	
●	Available
—	Not available

Symbol: C1 Add connecting ports on Body (A).
(An additionally machined port will have an aluminum surface since it will be left unfinished.)

- Parallel keyway is used on the long shaft for size 40.
- This specification is not available for the rotary actuator with auto switch unit.

Size	(mm)		
	Q	M	N
10	M3	8.5	9.5
15	M3	11	10
20	M5	14	13
30	M5	15.5	14
40	M5	21	20

Symbol: C2 Change 3 threaded holes on Body (B) into through holes. (An additionally machined port will have an aluminum surface since it will be left unfinished.)

- This specification is not available for the rotary actuator with auto switch unit.

Size	(mm)
	d
15	3.4
20	4.5
30	5.5
40	5.5

(Top view from long-shaft side)

Free-Mounting Type
CRBU2
CRB1

Series CRB2

Symbol: C3 Change the position of the screws for tightening the actuator body.

3-Hexagon socket head cap screw

A port B port

(Standard) (Altered)

(Top view from long-shaft side)

Symbol: C5 Applicable to single vane type only
Start of rotation is 45° up from the bottom of the vertical line to the left side.

- Rotation tolerance for CRB2BW10 is $^{+5}_{0}$ °.
- Port size for CRB2BW10, 15 is M3.
- A parallel keyway is used instead of chamfer for size 40.

Rotation range θ

End of rotation

Chamfer (Start of rotation)

A port (45°) B port

$\theta = \begin{matrix} \square & +4 \\ \square & 0 \end{matrix}$ °

Max. = 200°

Start of rotation is the position of the chamfer (keyway) when B port is pressurized.
(Top view from long-shaft side)

Symbol: C7 The shafts are reversed.

- A parallel keyway is used instead of chamfer for size 40.

Body (B)

Body (A)

X

Y

Size	Y	X
10	12	10
15	15.5	11.5
20	17	13
30	19	16
40	28	17

(mm)

Symbol: C4 Applicable to single vane type only
Change rotation range to 90°.
Start of rotation is horizontal line (90° down from the top to the right side).

- Rotation tolerance for CRB2BW10 is $^{+5}_{0}$ °.
- A parallel keyway is used instead of chamfer for size 40.

End of rotation

Rotation range 90°

Chamfer (Start of rotation)

A port B port

Start of rotation is the position of the chamfer (keyway) when A port is pressurized.
(Top view from long-shaft side)

Symbol: C6 Applicable to single vane type only
Start of rotation is horizontal line (90° down from the top to the left side).

- Rotation tolerance for CRB2BW10 is $^{+5}_{0}$ °.
- A parallel keyway is used instead of chamfer for size 40.

Rotation range θ

End of rotation

Chamfer (Start of rotation)

A port B port

$\theta = \begin{matrix} \square & +4 \\ \square & 0 \end{matrix}$ °

Max. = 110°

Start of rotation is the position of the chamfer (keyway) when B port is pressurized.
(Top view from long-shaft side)

Symbol: C30 Change standard grease to fluorine grease.
(Not for low-speed specification.)

Free-Mounting Rotary Actuator: Vane Type

Series CRBU2

Sizes: 10, 15, 20, 30, 40

		Fluid				Air														
		Size				10		15		20, 30		40								
Vane type		S: Single vane D: Double vane				S		D		S		D		S		D				
Port position		Side ports (Nil) Axial ports (E)				Side ports	Axial ports	Side ports	Axial ports	Side ports	Axial ports	Side ports	Axial ports	Side ports	Axial ports	Side ports	Axial ports			
Standard	Rotation	90°		●	●	●	●	●	●	●	●	●	●	●	●	●	●			
		100°				●	●			●	●			●	●					
		180°		●	●			●	●			●	●			●	●			
		270°		●	●			●	●			●	●			●	●			
	Shaft type	Double shaft		W	●	●	●	●	●	●	●	●	●	●	●	●	●			
	Cushion	Rubber bumper			●	●	●	●	●	●	●	●	●	●	●	●	●			
	Variations	Basic type			●	●	●	●	●	●	●	●	●	●	●	●	●			
		With auto switch			●	●			●	●			●	●			●	●		
		With angle adjuster			●	●			●	●			●	●			●	●		
		With auto switch and angle adjuster			●	●			●	●			●	●			●	●		
		Copper-free		20-	●	●	●	●	●	●	●	●	●	●	●	●	●			
	Made to Order	Shaft type	Double shaft	Long shaft without single flat & Short shaft with single flat		J	●	●	●	●	●	●	●	●	●		●	●		
				Long shaft without keyway & Short shaft with single flat													●	●	●	●
			Single shaft	Same length double long shaft with single flat on both shafts		Y	●	●	●	●	●	●	●	●	●	●				
				Double shaft key														●	●	●
Double round shaft				K	●	●	●	●	●	●	●	●	●	●	●	●	●	●	●	
Pattern		Single flat		S	●	●	●	●	●	●	●	●	●	●	●					
		Single shaft key														●	●	●	●	
		Single round shaft		T												●	●	●	●	
Shaft pattern			●	●	●	●	●	●	●	●	●	●	●	●	●	●	●	●		
Rotation pattern			●	●			●	●			●	●			●	●				

CRB2

Free-Mounting Type
CRBU2

CRB1

Rotary Actuator: Free-Mounting Type

Series CRBU2

Sizes: 10, 15, 20, 30, 40

How to Order

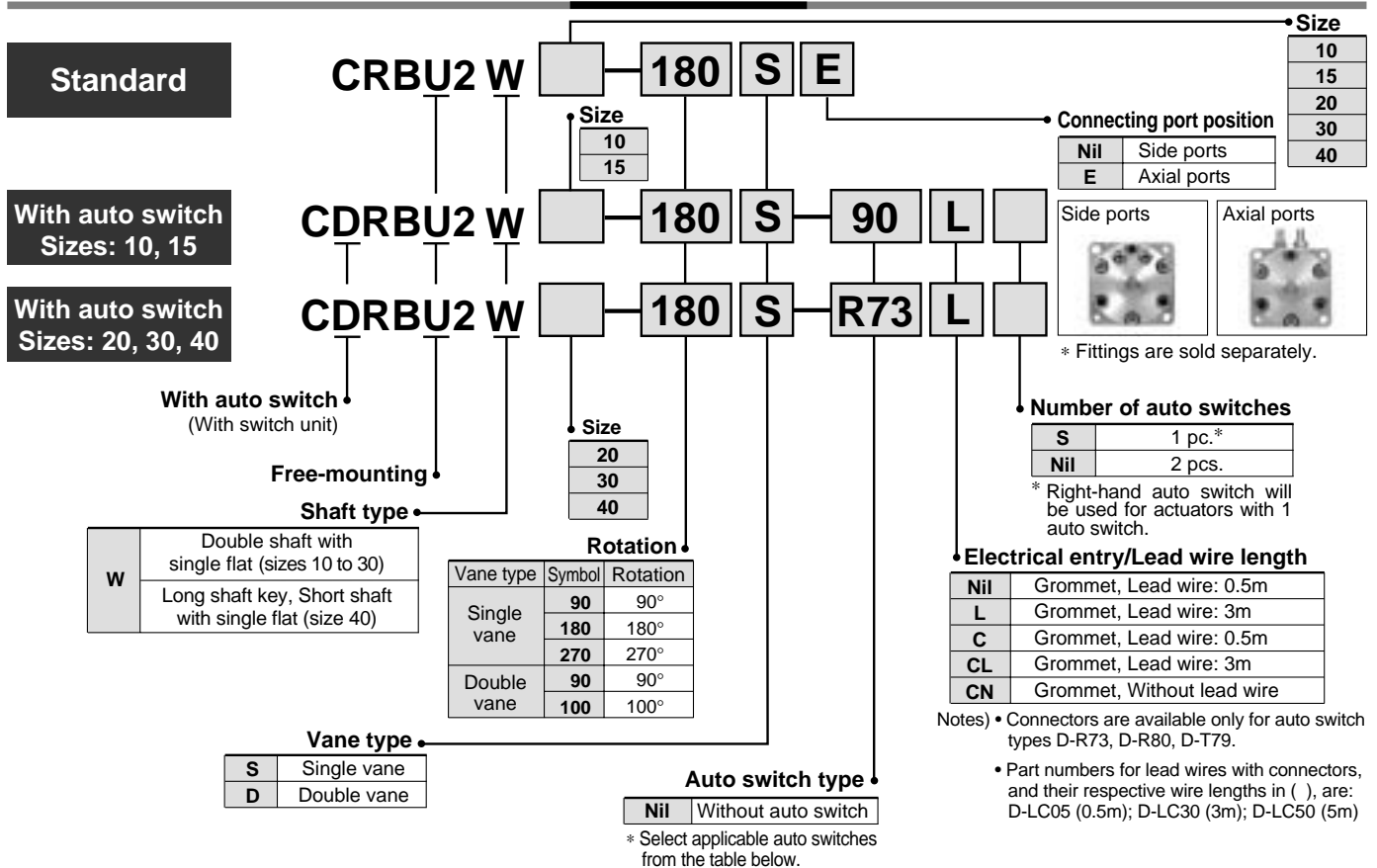

Auto switch specifications: Refer to page 91 for detailed auto switch specifications.

Applicable size	Type	Electrical entry	Indicator light	Wiring (output)	Load voltage		Auto switch part no.	Lead wire type	Lead wire length*				Applicable loads			
					DC	AC			0.5 (Nil)	3 (L)	5 (Z)	None (N)				
															24V	24V
For 10 and 15	Reed	Grommet	No	2-wire	24V	5V, 12V	5V, 12V, 24V	90	Parallel cord	●	●	●	—	IC circuit	Relay PLC	
						5V, 12V, 100V	5V, 12V, 24V, 100V	90A	Heavy-duty cord	●	●	●	—			
						—	—	97	Parallel cord	●	●	●	—			
						—	100V	93A	Heavy-duty cord	●	●	●	—			
						—	—	T99	Heavy-duty cord	●	●	—	—			
	Solid state	Grommet	Yes	3-wire (NPN)	24V	5V, 12V	—	T99V	Heavy-duty cord	●	●	—	—	IC circuit	Relay PLC	
								S99	Heavy-duty cord	●	●	—	—			
								S99V	Heavy-duty cord	●	●	—	—			
								S9P	Heavy-duty cord	●	●	—	—			
								S9PV	Heavy-duty cord	●	●	—	—			
For 20, 30, and 40	Reed	Grommet	Yes	2-wire	24V	—	100V	Heavy-duty cord	●	●	—	—	IC circuit	Relay PLC		
							48V, 100V	24V, 48V, 100V	R80	Heavy-duty cord	●	●			—	—
							—	—	R80C	Heavy-duty cord	●	●			●	●
							—	—	T79	Heavy-duty cord	●	●			—	—
							—	—	T79C	Heavy-duty cord	●	●			●	●
	Solid state	Grommet	Yes	3-wire (NPN)	24V	5V, 12V	—	S79	Heavy-duty cord	●	●	—	—	IC circuit	Relay PLC	
								S79V	Heavy-duty cord	●	●	—	—			
								S7P	Heavy-duty cord	●	●	—	—			
								S7PV	Heavy-duty cord	●	●	—	—			
								—	—	S79C	Heavy-duty cord	●	●			—

* Lead wire length symbol 0.5m Nil (Example) R73C 5m Z (Example) R73CZ
 3mL (Example) R73CL None N (Example) R73CN

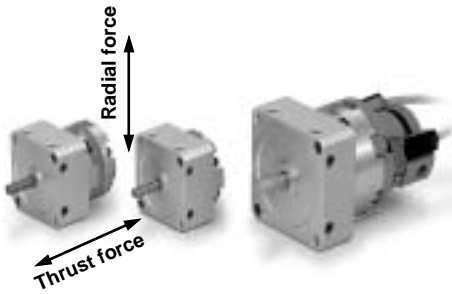

Single Vane Specifications

Model (Size)	CRBU2W10-□S	CRBU2W15-□S	CRBU2W20-□S	CRBU2W30-□S	CRBU2W40-□S
Rotation	90°, 180°, 270°				
Fluid	Air (non-lube)				
Proof pressure (MPa)	1.05			1.5	
Ambient and fluid temperature	5° to 60°C				
Max. operating pressure (MPa)	0.7			1.0	
Min. operating pressure (MPa)	0.2	0.15			
Speed regulation range (sec/90°) ^{Note 1)}	0.03 to 0.3			0.04 to 0.3	0.07 to 0.5
Allowable kinetic energy (J) ^{Note 2)}	0.00015	0.001	0.003	0.02	0.04
		0.00025	0.0004	0.015	0.033
Shaft load	Allowable radial load (N)	15	25	30	60
	Allowable thrust load (N)	10	20	25	40
Bearing type	Ball bearing				
Port position	Side ports or axial ports				
Shaft type	Double shaft (Double shaft with single flat on both shafts)				Double shaft (Long shaft key & Single flat)
Adjustable angle range	0° to 230°	0° to 240°			0° to 230°

Double Vane Specifications

Model (Size)	CRBU2W10-□D	CRBU2W15-□D	CRBU2W20-□D	CRBU2W30-□D	CRBU2W40-□D
Rotation	90°, 100°				
Fluid	Air (non-lube)				
Proof pressure (MPa)	1.05			1.5	
Ambient and fluid temperature	5° to 60°C				
Max. operating pressure (MPa)	0.7			1.0	
Min. operating pressure (MPa)	0.2	0.15			
Speed regulation range (sec/90°) ^{Note 1)}	0.03 to 0.3			0.04 to 0.3	0.07 to 0.5
Allowable kinetic energy (J)	0.0003	0.0012	0.0033	0.02	0.04
Shaft load	Allowable radial load (N)	15	25	30	60
	Allowable thrust load (N)	10	20	25	40
Bearing type	Ball bearing				
Port position	Side ports or axial ports				
Shaft type	Double shaft (Double shaft with single flat on both shafts)				Double shaft (Long shaft key & Single flat)
Adjustable angle range	0° to 90°				0° to 230°

JIS symbol

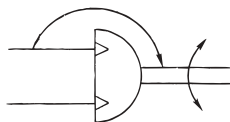

* The following notes apply to both Single and Double Vane Specification tables above.
 Note 1) Make sure to operate within the speed regulation range. Exceeding the maximum speeds can cause the unit to stick or not operate.
 Note 2) The upper numbers in this section in the table indicate the energy factor when the rubber bumper is used (at the end of the rotation), and the lower numbers indicate the energy factor when the angle adjuster is used.

Inner Volume and Connection Ports

Vane type	Model (Size)	CRBU2W10			CRBU2W15			CRBU2W20			CRBU2W30			CRBU2W40				
Single vane	Rotation	90°	180°	270°	90°	180°	270°	90°	180°	270°	90°	180°	270°	90°	180°	270°		
	Volume (cm ³)*	1 (0.6)	1.2	1.5	1.5 (1.0)	2.9	3.7	4.8 (3.5)	6.1	7.9	11.3 (8.5)	15	20.2	25	31.5	41		
	Port size	Side ports	M5															
Double vane	Rotation	90°	100°	90°	100°	90°	100°	90°	100°	90°	100°	90°	100°	90°	100°	90°	100°	
	Volume (cm ³)	1	1.1	2.6	2.7	5.6	5.7	14.4	14.5	33	34							
	Port size	Side ports	M5						M5									
		Axial ports	M3															

* Values inside () are volume of the supply side when A port is pressurized.

Caution

Be sure to read before handling. Refer to pages 104 through 110 for safety precautions, actuator precautions, and auto switch precautions.

Weights

Vane type	Model (Size)	CRBU2W10			CRBU2W15			CRBU2W20			CRBU2W30			CRBU2W40		
Single vane	Rotation	90°	180°	270°	90°	180°	270°	90°	180°	270°	90°	180°	270°	90°	180°	270°
	Body of rotary actuator	47.5	47.1	47	73	72	72	143	142	140	263	258	255	491	480	469
	Auto switch unit + 2 switches	30			30			50			60			46.5		
	Angle adjuster	30			47			90			150			203		
Double vane	Rotation	—	90°	100°	—	90°	100°	—	90°	100°	—	90°	100°	—	90°	100°
	Body of rotary actuator	—	62.2	63.2	—	77	81	—	151	158	—	289	308	—	504	550
	Auto switch unit + 2 switches	30			30			50			60			46.5		
	Angle adjuster	30			47°			90			150			203		

Series CRBU2

Rotary Actuator: Replaceable Shaft

A shaft can be replaced with a different shaft type except for standard shaft type (W).

Without auto switch CRBU2 **J** Size — Rotation — Vane type — Port position

• Shaft type

Symbol	Shaft type	Shaft-end shape	Size				
			10	15	20	30	40
J	Double shaft	Long shaft without single flat & with single flat	●	●	●	●	●
		Long shaft without keyway & with single flat					●
K	Double shaft	Double round shaft	●	●	●	●	●
S	Single shaft	Single shaft with single flat	●	●	●	●	
		Single shaft key					●
T	Single shaft	Single round shaft	●	●	●	●	●
Y	Double shaft	Double shaft with single flat	●	●	●	●	●
		Double shaft key					●

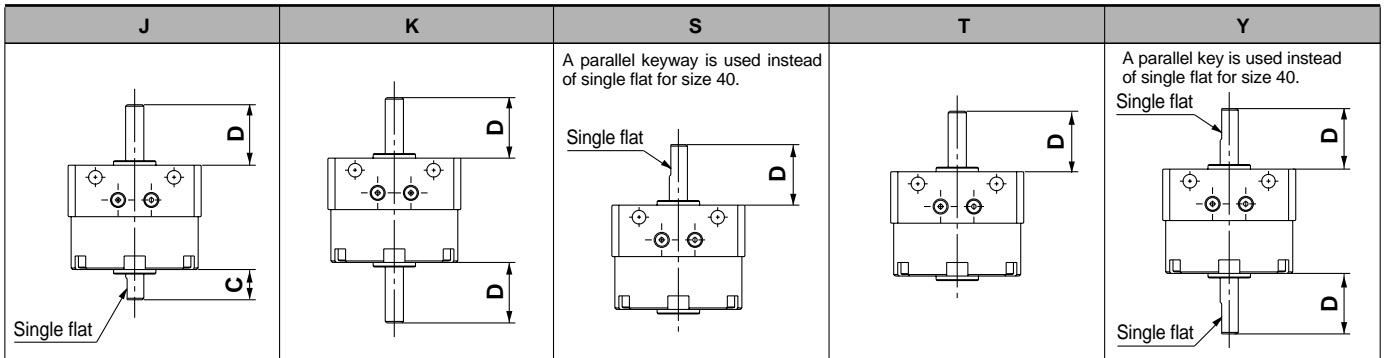

(mm)

Size	10	15	20	30	40
C	8	9	10	13	15
D	14	18	20	22	30

- Notes) • Only side ports are available except for basic type.
 • Dimensions and tolerance of the shaft and single flat (a parallel keyway for size 40) are the same as the standard.

With auto switch & With angle adjuster CDRBU2 J U Size — Rotation — Vane type — Auto switch

• With angle adjuster
 • Shaft type

Symbol	Shaft type	Shaft-end shape	Size				
			10	15	20	30	40
J	Double shaft	Long shaft without single flat & with single flat	●	●	●	●	
		Long shaft without keyway & single flat					●

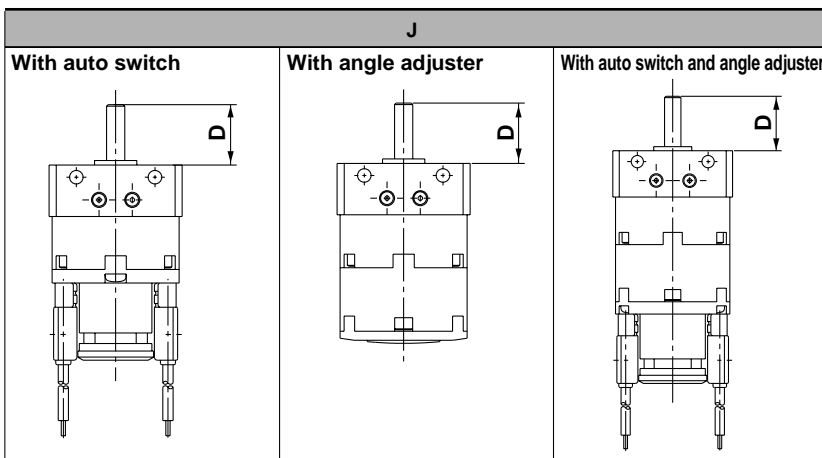

(mm)

Size	10	15	20	30	40
C	8	9	10	13	15
D	14	18	20	22	30

- Notes) • Only side ports are available except for basic type.
 • Dimensions and tolerance of the shaft and single flat (a parallel keyway for size 40) are the same as the standard.

Copper-Free Rotary Actuator

20 – CRBU2W Size Rotation Vane type Port position

↓ Copper-free

Use the standard vane type rotary actuators in all series to prevent any adverse effects to colour CRTs* due to copper ions or fluororesin.

Specifications

Vane type	Single/Double vane				
Size	10	15	20	30	40
Operating pressure range (MPa)	0.2 to 0.7	0.15 to 0.7		0.15 to 1.0	
Speed regulation range (s/90°)	0.03 to 0.3		0.04 to 0.3	0.07 to 0.5	
Port position	Side ports or axial ports				
Piping	Screw-in piping				
Mounting	Basic type only				
Variations	Basic type, with auto switch				

*CRT= Cathode ray tubes

⚠ Specific Product Precautions

Be sure to read before handling.
Refer to pages 104 through 110 for safety instructions, actuator precautions, and auto switch precautions.

Angle Adjuster

⚠ Caution

1. Since the maximum angle of the rotation adjustment range will be limited by the rotation of the rotary actuator itself, make sure to take this into consideration when ordering.

Rotation of the rotary actuator	Rotation adjustment range
270° ⁺⁴ ₀	0° to 230° (Sizes: 10, 40)*
	0° to 240° (Sizes: 15, 20, 30)
180° ⁺⁴ ₀	0° to 175°
90° ⁺⁴ ₀	0° to 85°

* The maximum adjustment angle of the angle adjuster for size 10 and 40 is 230°.

2. Connecting ports are side ports only.
3. The allowable kinetic energy is the same as the specifications of the rotary actuator by itself (i.e., without angle adjuster).
4. Use a 100° rotary actuator if you desire to adjust the angle to 90° using a double vane type.

CRB2

Free-Mounting Type
CRBU2

CRB1

Series CRBU2

Effective Output

CRBU2W10

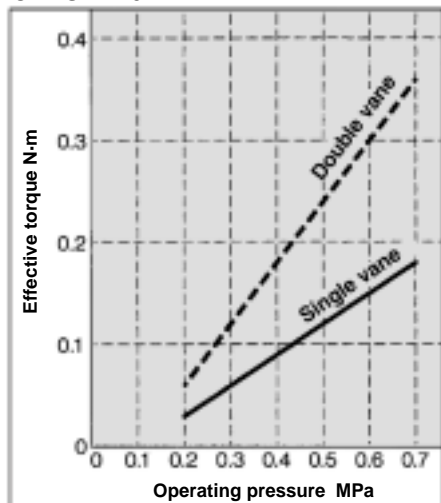

CRBU2W15

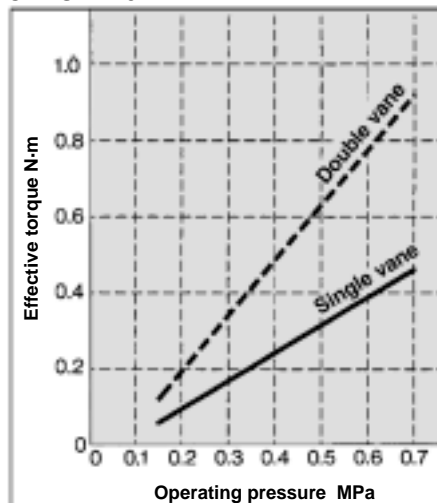

CRBU2W20

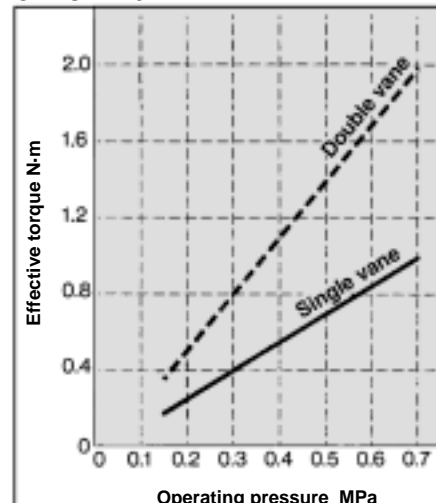

CRBU2W30

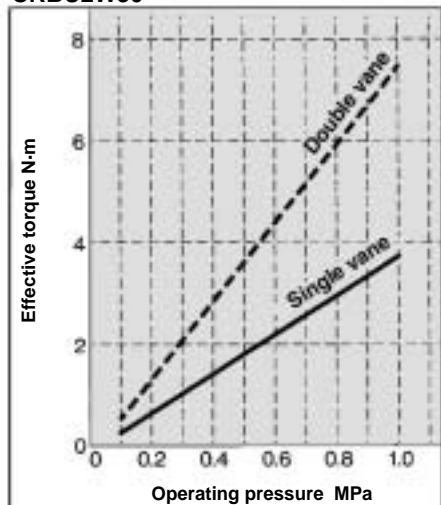

CRBU2W40

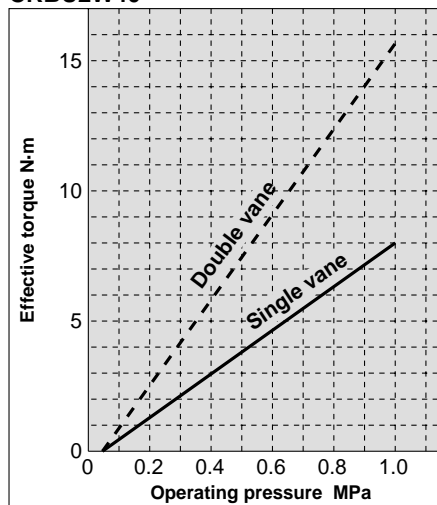

Chamfered Position and Rotation Range: Top View from Long Shaft Side

(Chamfered positions shown below illustrate the conditions of the actuators when B port is pressurized.)

Single vane type

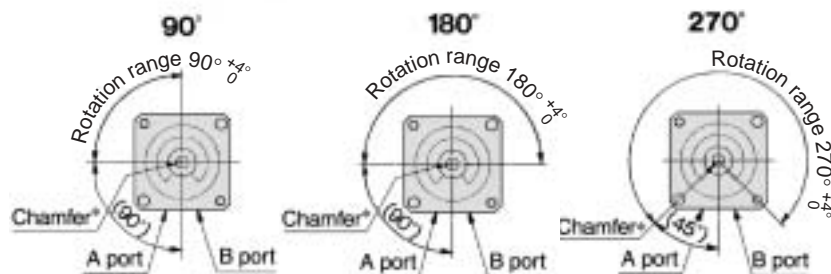

Double vane type

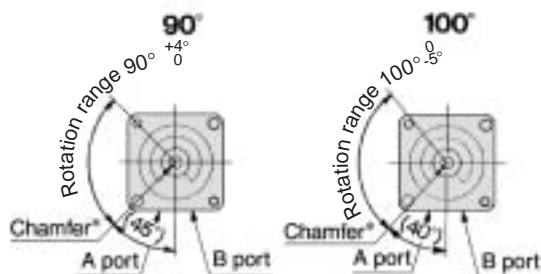

* For size 40 actuators, a parallel keyway will be used instead of chamfer.

Note) For single vane type, rotation tolerance of 90°, 180°, and 270° actuators will be $^{+5}_0$ for size 10 actuators only.

For double vane type, rotation tolerance of 90° actuators will be $^{+5}_0$ for size 10 actuators only.

Construction: 10, 15, 20, 30, 40

Single vane type

Standard: CRBU2W10, 15, 20, 30, 40-□S

(3 female threads (one of them is indicated with "**") spaced equally apart in 120° are not available for size 10.)

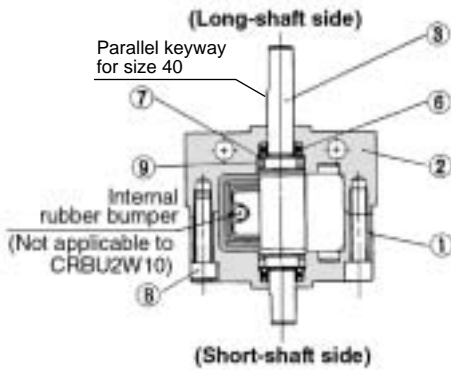

Parts list

No.	Description	Material	Note
1	Body (A)	Aluminum alloy	
2	Body (B)	Aluminum alloy	
3	Vane shaft	Stainless steel*	
4	Stopper	Resin	For 270°
5	Stopper	Resin	For 180°
6	Bearing	High carbon chromium steel	
7	Back-up ring	Stainless steel	
8	Hexagon socket head cap screw	Stainless steel	Special screw
9	O-ring	NBR	
10	Stopper seal	NBR	Special seal

*Carbon steel for CRBU2W30 and CRBU2W40.

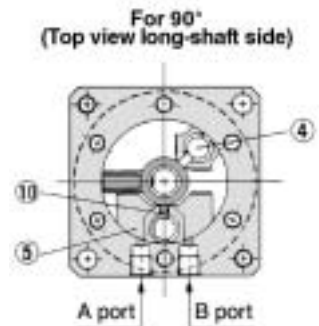
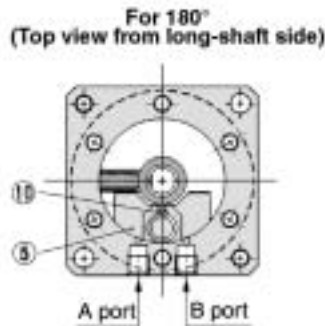
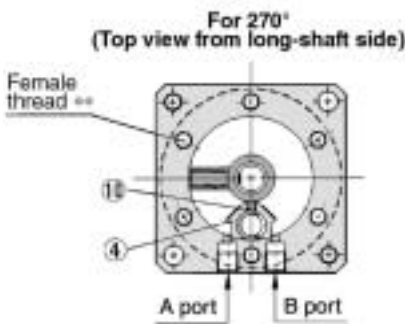

With auto switch unit (Same switch units are used for both single and double vane types.)

CDRBU2W10, 15-□^S_D

CDRBU2W20, 30, 40-□^S_D

CDRBU2W40-S, D

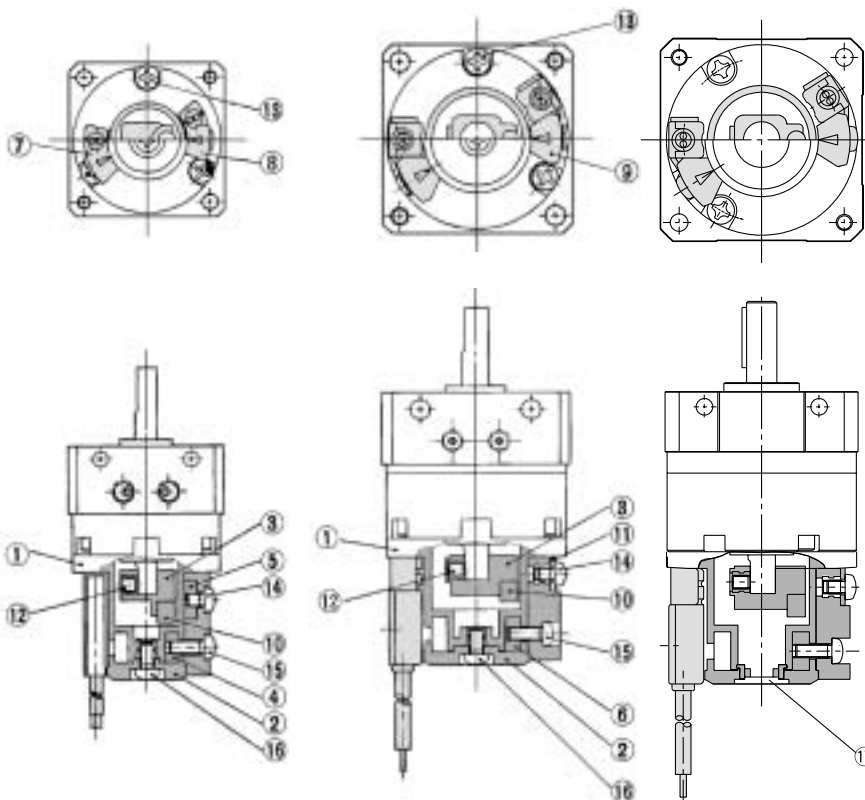

Parts list

No.	Description	Material
1	Cover (A)	Resin
2	Cover (B)	Resin
3	Magnet lever	Resin
4	Holding block (A)	Aluminum alloy
5	Holding block (B)	Aluminum alloy
6	Holding block	Aluminum alloy
7	Switch block (A)	Resin
8	Switch block (B)	Resin
9	Switch block	Resin
10	Magnet	Magnetic body
11	Arm	Stainless steel
12	Hexagon socket head set screw	Stainless steel
13	Round head Phillips screw	Stainless steel
14	Round head Phillips screw	Stainless steel
15	Round head Phillips screw	Stainless steel
16	Round head Phillips screw	Stainless steel
17	Rubber cap	NBR (size 40 only)

* For CDRBU2W10, two round head Phillips screws, ⑬, are required.

Series CRBU2

Construction: 10, 15, 20, 30, 40

Double vane type

Standard: CRBU2W10-□D

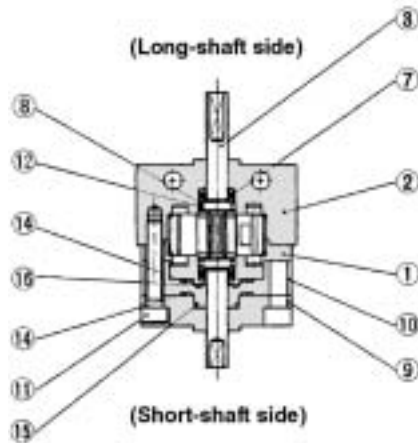

For 90°
(Top view from long-shaft side)

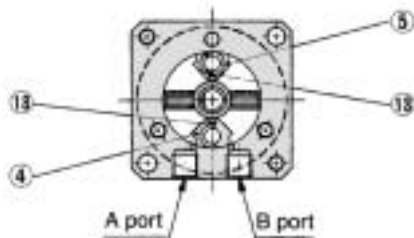

For 100°
(Top view from long-shaft side)

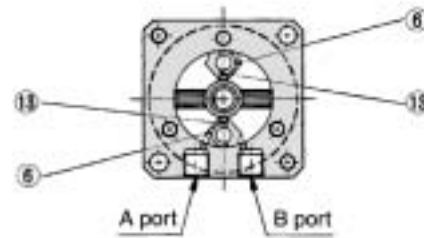

Parts list

No.	Description	Material	Note
1	Body (A)	Aluminum alloy	
2	Body (B)	Aluminum alloy	
3	Vane shaft	Carbon steel	
4	Stopper	Stainless steel	
5	Stopper	Resin	
6	Stopper	Stainless steel	
7	Bearing	High carbon chromium bearing steel	
8	Back-up ring	Stainless steel	
9	Cover	Aluminum alloy	
10	Plate	Resin	
11	Hexagon socket head cap screw	Stainless steel	Special screw
12	O-ring	NBR	
13	Stopper seal	NBR	
14	Gasket	NBR	
15	O-ring	NBR	
16	O-ring	NBR	

Standard: CRBU2W15, 20, 30, 40-□D

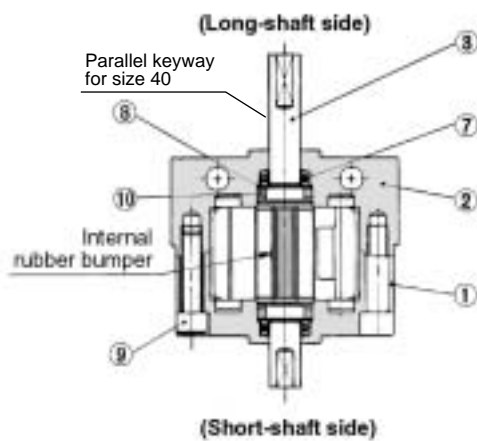

For 90°
(Top view from long-shaft side)

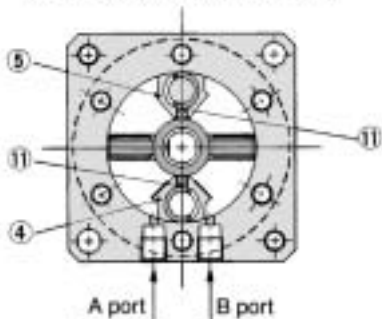

For 100°
(Top view from long shaft side)

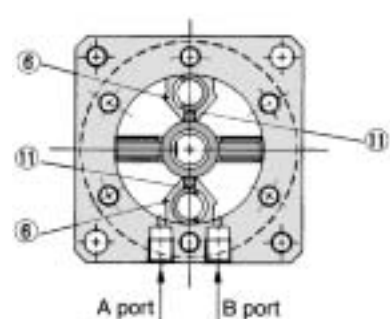

Parts list

No.	Description	Material	Note
1	Body (A)	Aluminum alloy	
2	Body (B)	Aluminum alloy	
3	Vane shaft	Carbon steel	
4	Stopper	Stainless steel	
5	Stopper	Resin	
6	Stopper	Stainless steel	
7	Bearing	High carbon chromium bearing steel	
8	Back-up ring	Stainless steel	
9	Hexagon socket head cap screw	Stainless steel	Special screw
10	O-ring	NBR	
11	Stopper seal	NBR	

Dimensions: 10, 15, 20, 30

Single vane type

• Following illustrations show actuators for 90° and 180° when B port is pressurized.

CRBU2W□-□S

<Port position: Side ports>

CRBU2W□-□SE

<Port position: Axial ports>

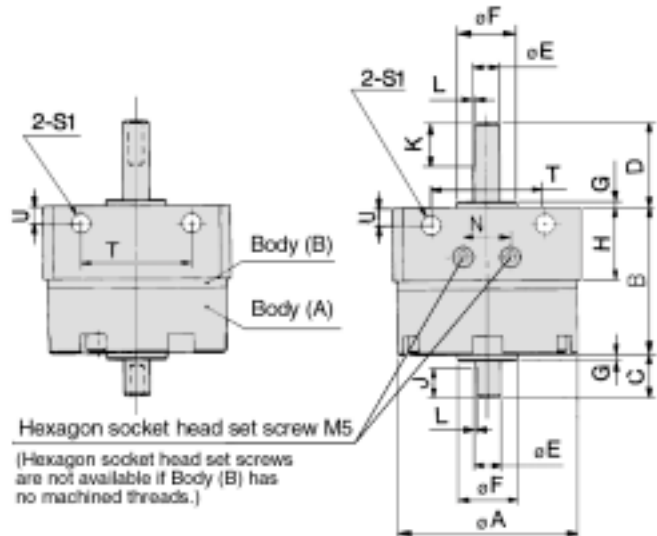
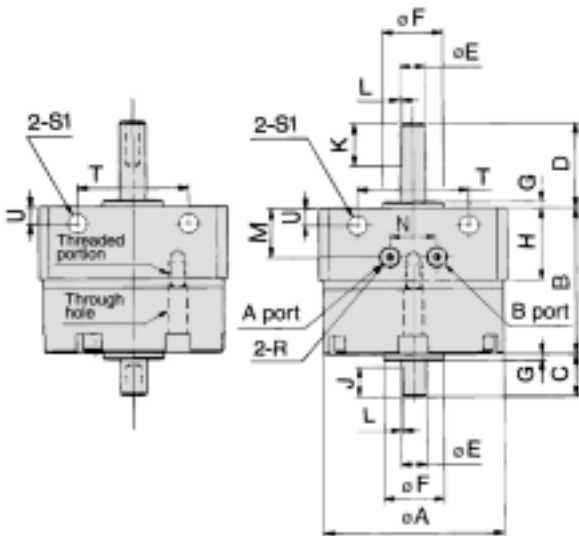
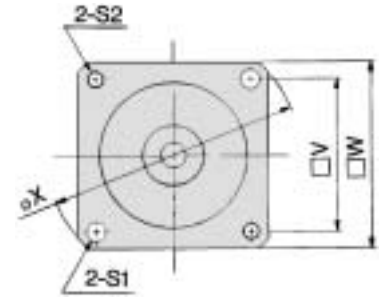
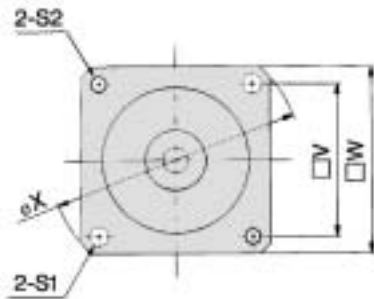

CRBU2W10□-□S

<Port position: Side ports>

CRBU2W10□-□SE

<Port position: Axial ports>

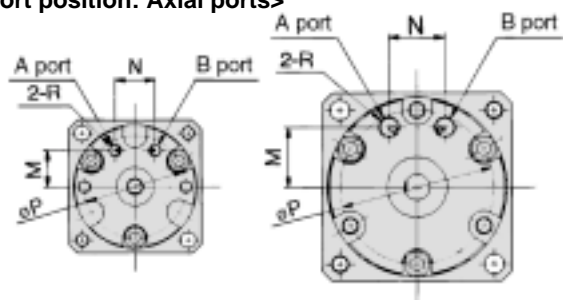
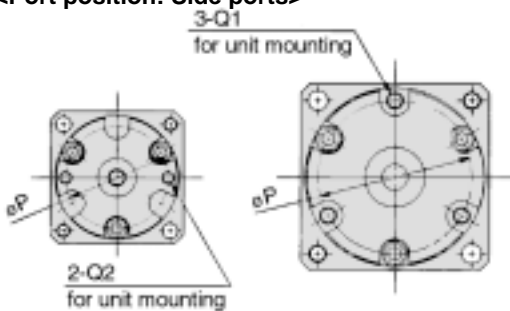

(mm)

Model	A	B	C	D	E (g6)	F (h9)	G	H	J	K	L	M	N	P	Q1	(depth) Q2	R	S1	S2	T	U	V	W	X
CRBU2W10-□S	29	22	8	14	4 ^{-0.004} _{-0.012}	9 ⁰ _{-0.036}	1	15.5	5	9	0.5	10.5	10.5	24	—	M3 (4)	M5	3.5	M3	17	3	25	31	41
CRBU2W10-□SE												M3												
CRBU2W15-□S	34	25	9	18	5 ^{-0.004} _{-0.012}	12 ⁰ _{-0.043}	1.5	15.5	6	10	0.5	10.5	10.5	29	M3	—	M5	3.5	M3	21	3	29	36	48
CRBU2W15-□SE												M3												
CRBU2W20-□S	42	34.5	10	20	6 ^{-0.004} _{-0.012}	14 ⁰ _{-0.043}	1.5	17	7	10	0.5	11.5	11	36	M4	—	M5	4.5	M4	26	4	36	44	59
CRBU2W20-□SE												M3												
CRBU2W30-□S	50	47.5	13	22	8 ^{-0.005} _{-0.014}	16 ⁰ _{-0.043}	2	17.5	8	12	1	12	13	43	M5	—	M5	5.5	M5	29	4.5	42	52	69
CRBU2W30-□SE												M3												

Dimensions: 40

Single vane/Double vane type

CRBU2W40-□S, D

<Port position: Side ports>

CRBU2W40-□SE, DE
<Port position: Axial ports>

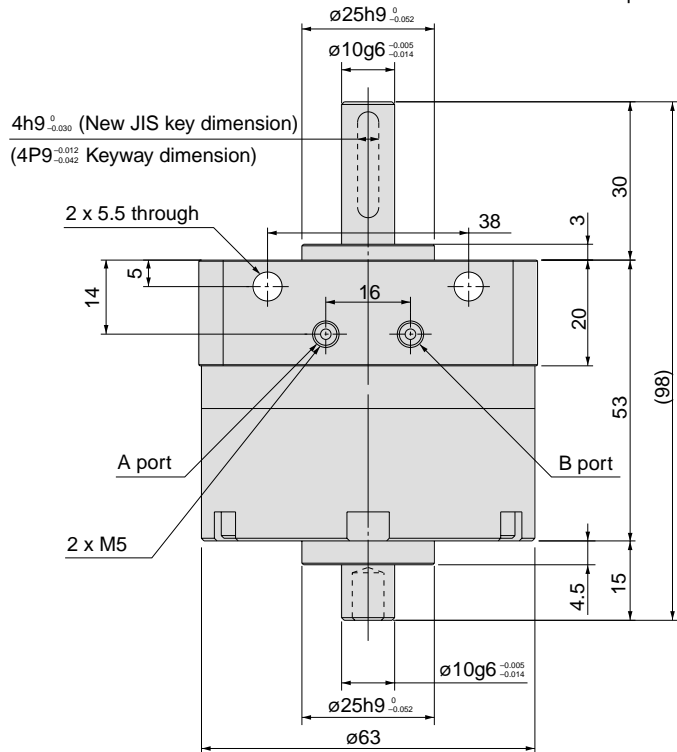
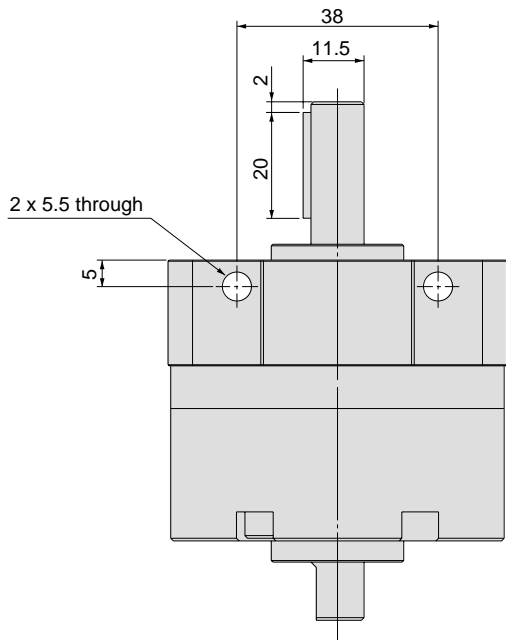
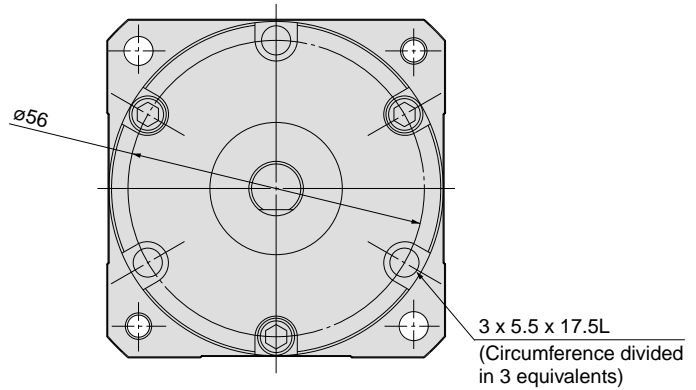
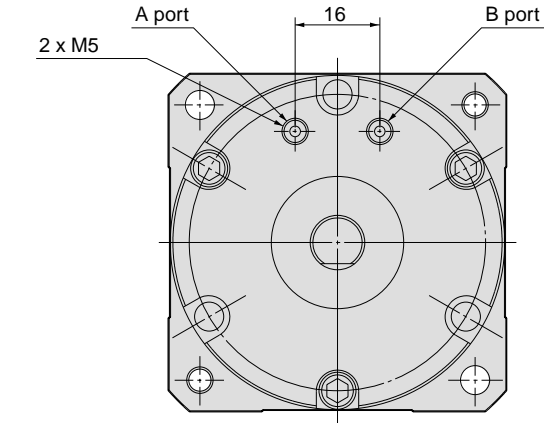

Keyway dimensions			
	b (h9)	h (h9)	L
Model	b (h9)	h (h9)	L
CRBU2W40-□□□	$4 \begin{smallmatrix} 0 \\ -0.030 \end{smallmatrix}$	$4 \begin{smallmatrix} 0 \\ -0.030 \end{smallmatrix}$	20

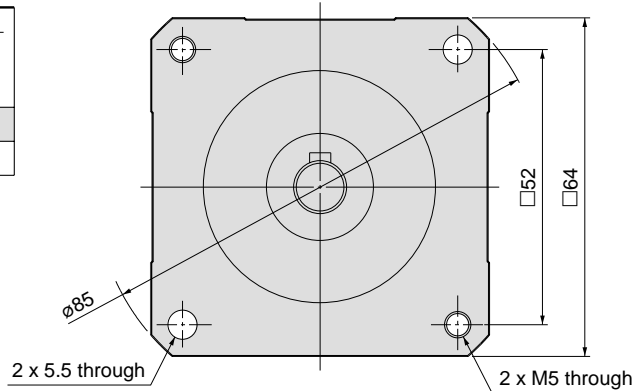

CRB2

Free-Mounting Type
CRBU2

CRB1

Series CDRBU2

Dimensions: 10, 15, 20, 30 (with Auto Switch Unit)

Single vane type

• Following illustrations show actuators for 90° and 180° when B port is pressurized.

CDRBU2W10, 15-□S

CDRBU2W20, 30-□S

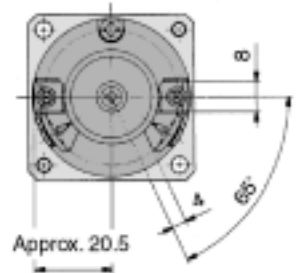
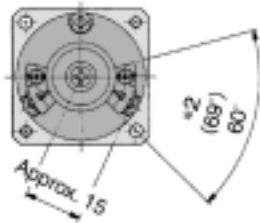

(Approx. 26.5 for connector type)

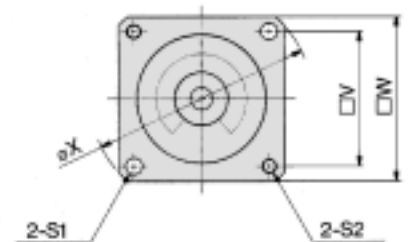
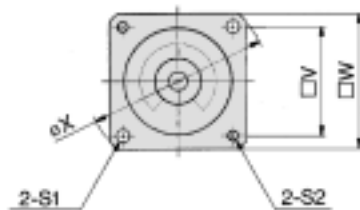
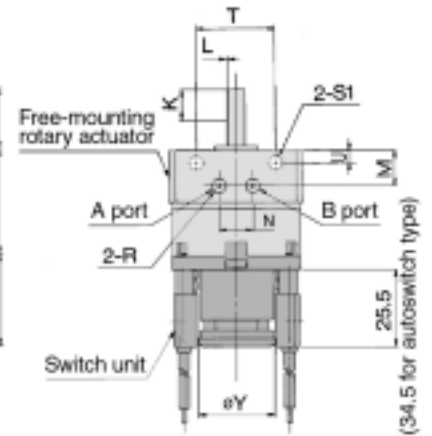
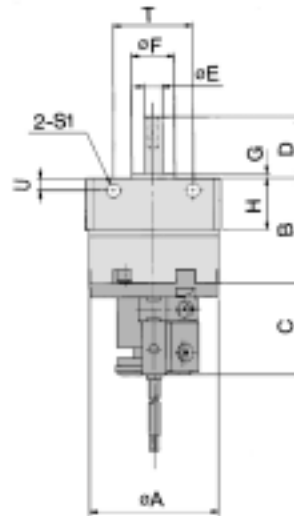
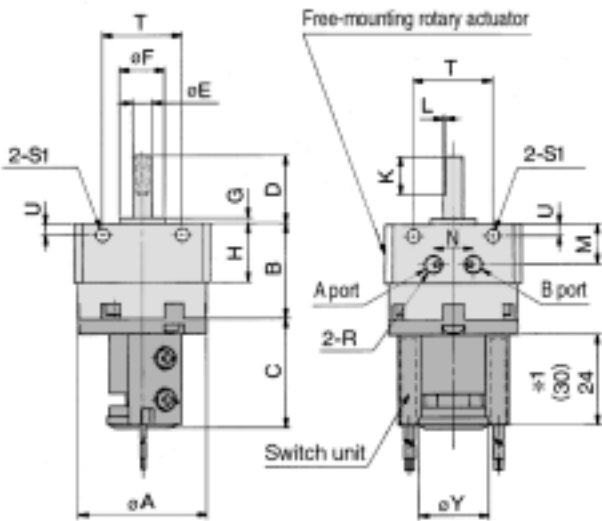

- *1. The length is 24 when any of the following auto switches are used:
D-90, D-90A, D-S99(V), D-T99(V), and D-S9P(V)
The length is 30 when any of the following auto switches are used:
D-97 and D-93A
- *2. The angle is 60° when any of the following auto switches are used:
D-90, D-90A, D-97, and D-93A.
The angle is 69° when any of the following auto switches are used:
D-S99(V), D-T99(V), and D-S9P(V)



Note • For rotary actuators with auto switch unit, connecting ports are side ports only.
• The above exterior view drawings illustrate rotary actuators with one right-hand and one left-hand switches.

Model	A	B	C	D	E (g6)	F (h9)	G	H	K	L	M	N	R	S1	S2	T	U	V	W	X	Y
CDRBU2W10-□S	29	22	29	14	4 ^{-0.004} _{-0.012}	9 ⁰ _{-0.036}	1	15.5	9	0.5	10.5	10.5	M5	3.5	M3	17	3	25	31	41	18.5
CDRBU2W15-□S	34	25	29	18	5 ^{-0.004} _{-0.012}	12 ⁰ _{-0.043}	1.5	15.5	10	0.5	10.5	10.5	M5	3.5	M3	21	3	29	36	48	18.5
CDRBU2W20-□S	42	34.5	30	20	6 ^{-0.004} _{-0.012}	14 ⁰ _{-0.043}	1.5	17	10	0.5	11.5	11	M5	4.5	M4	26	4	36	44	59	25
CDRBU2W30-□S	50	47.5	31	22	8 ^{-0.005} _{-0.014}	16 ⁰ _{-0.043}	2	17.5	12	1	12	13	M5	5.5	M5	29	4.5	42	52	69	25

Double vane type
CDRBU2W10-□D

• Illustrations below show the intermediate rotation position when A or B port is pressurized.

CDRBU2W15, 20, 30-□D

(Illustrations below show size 20 actuators.)

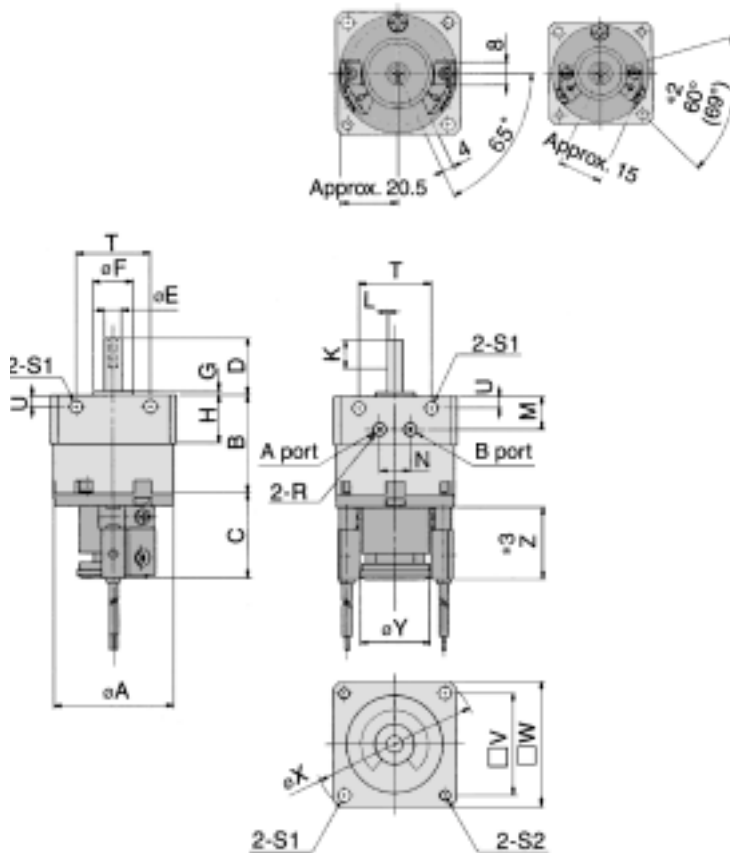
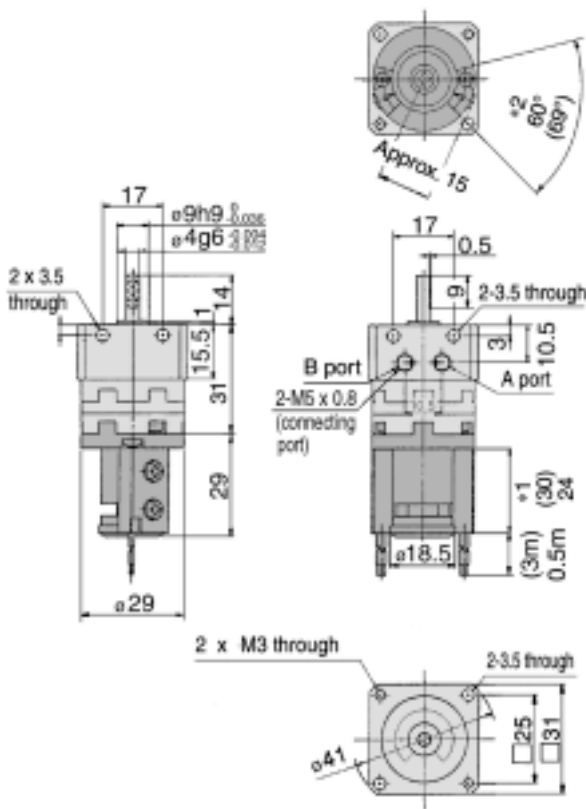

CDRBU2W15-□D

(Approx. 26.5 for connector type)
CDRBU2W20, 30-□D

*1. The length is 24 when any of the following auto switches are used: D-90, D90A, D-S99(V), D-T99(V), and D-S9P(V)
The length is 30 when any of the following auto switches are used: D-97 and D-93A

*2. The angle is 60° when any of the following auto switches are used: D-90, D-90A, D-97, and D-93A.
The angle is 69° when any of the following auto switches are used: D-S99(V), D-T99(V), and D-S9P(V)

*3. The length (Dimension S) is 25.5 when any of the following grommet type auto switches are used: D-R73, D-R80, D-S79, D-T79, and D-S7P
The length (Dimension S) is 34.5 when any of the following connector type auto switches are used: D-R73, D-R80, and D-T79

Model	A	B	C	D	E (g6)	F (h9)	G	H	K	L	M	N	R	S1	S2	T	U	V	W	X	Y	Z	
CDRBU2W15-□D	34	25	29	18	5 ^{-0.004} _{-0.012}	12 ⁰ _{-0.043}	1.5	15.5	10	0.5	10.5	10.5	M5	3.5	M3	21	3	29	36	48	18.5	24 ^{*1}	30 ^{*1}
CDRBU2W20-□D	42	34.5	30	20	6 ^{-0.004} _{-0.012}	14 ⁰ _{-0.043}	1.5	17	10	0.5	11.5	11	M5	4.5	M4	26	4	36	44	59	25	25.5 ^{*3}	34.5 ^{*3}
CDRBU2W30-□D	50	47.5	31	22	8 ^{-0.005} _{-0.014}	16 ⁰ _{-0.043}	2	17.5	12	1	12	13	M5	5.5	M5	29	4.5	42	52	69	25	25.5 ^{*3}	34.5 ^{*3}

CRB2

Free-Mounting Type
CRBU2

CRB1

Series CDRBU2

Dimensions: 40 (with Auto Switch Unit)

Single vane/Double vane type

CDRBU2W40-□□S, D

Keyway dimension			
Model	b (h9)	h (h9)	L
CDRBU2W40-□□□	$4_{-0.030}^0$	$4_{-0.030}^0$	20

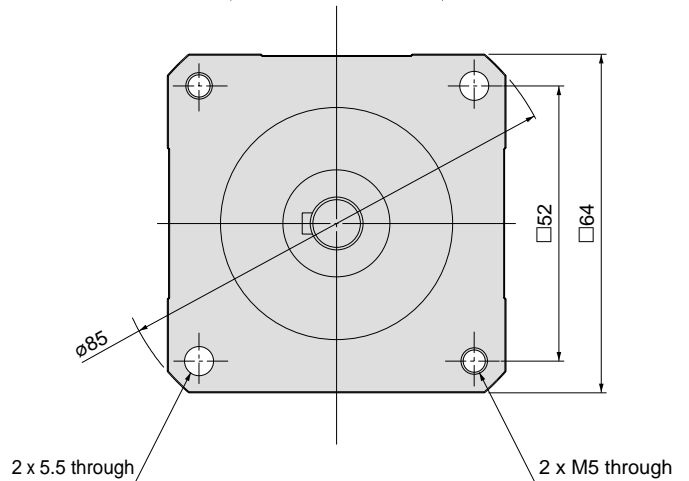
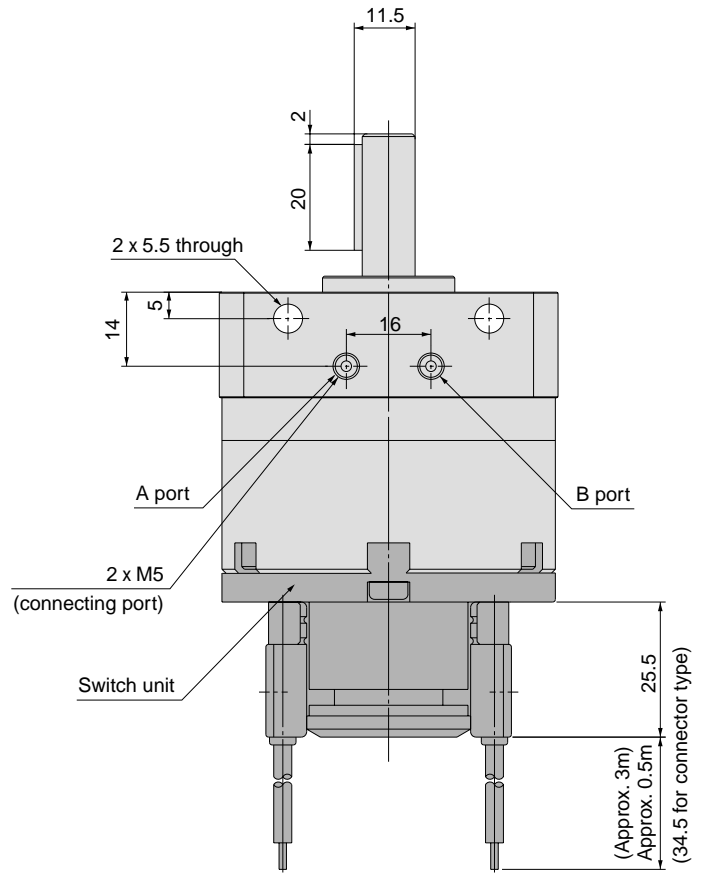
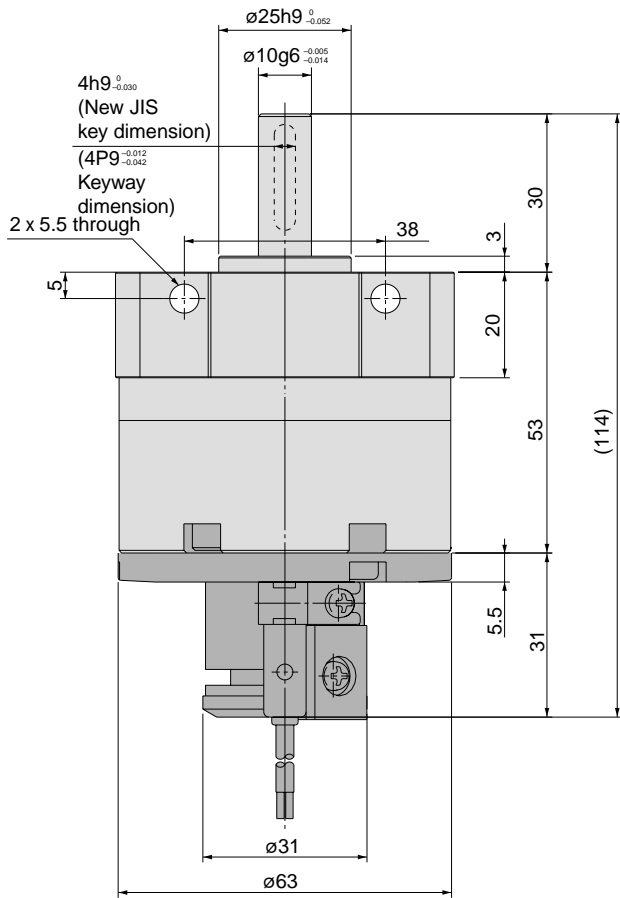
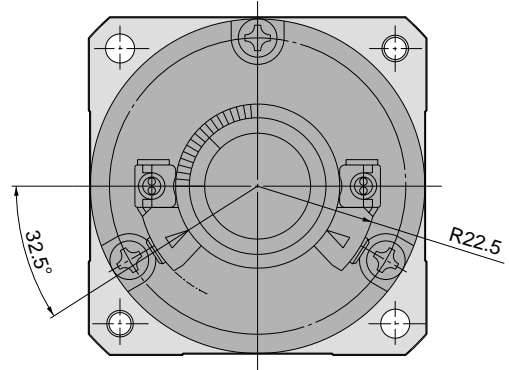

CRB2

Free-Mounting Type
CRBU2

CRB1

Rotary Actuator with Angle Adjuster Free-Mounting Type

Series CRBU2WU

Sizes: 10, 15, 20, 30, 40

How to Order

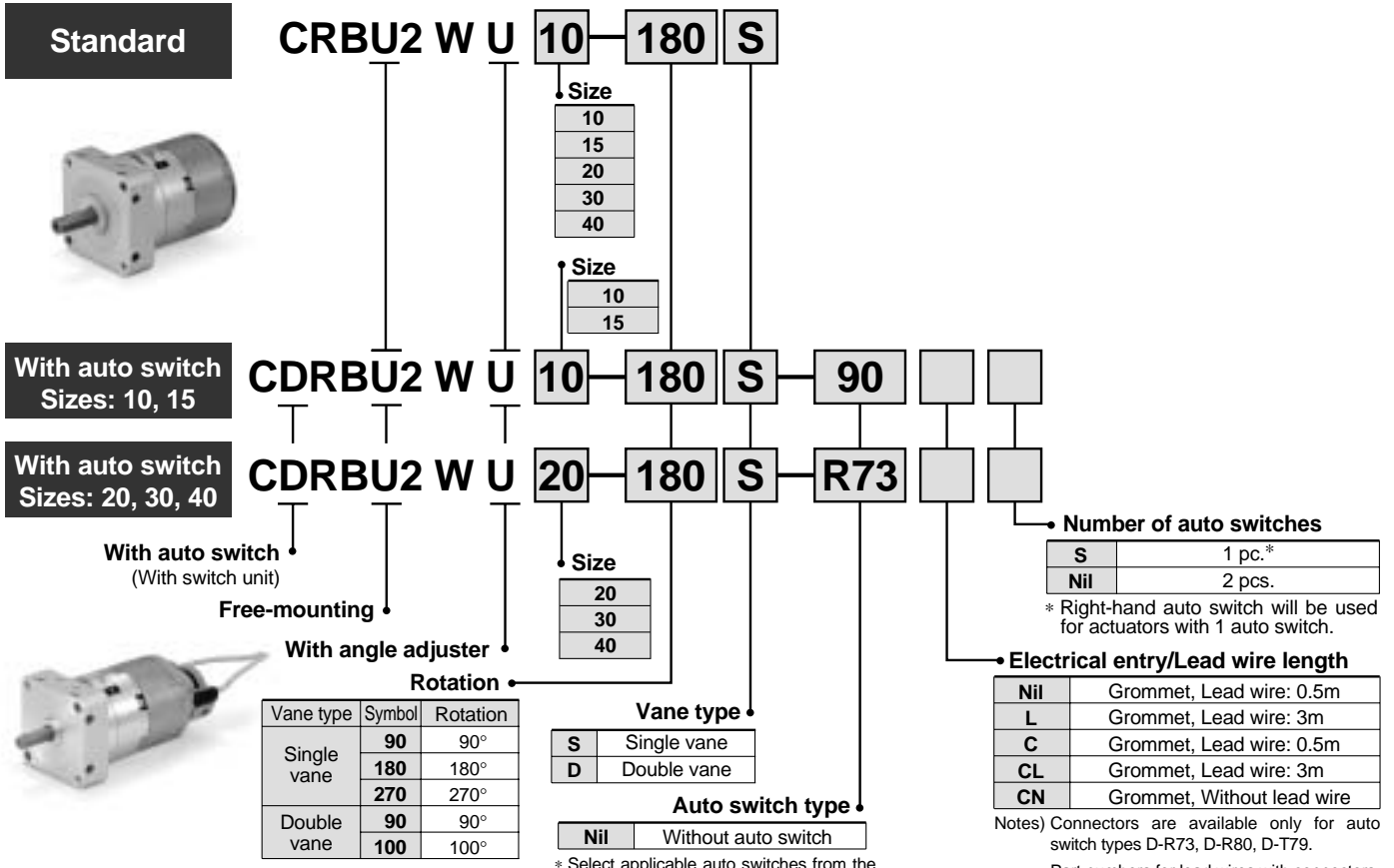

Auto switch specifications: Refer to page 91 for detailed auto switch specifications.

Applicable size	Type	Electrical entry	Indicator light	Wiring (output)	Load voltage		Auto switch part no.	Lead wire type	Lead wire length (m)*				Applicable loads	
					DC	AC			0.5 (Nil)	3 (L)	5 (Z)	None (N)		
For 10 and 15	Reed	Grommet	No	2-wire	5V, 12V	5V, 12V, 24V	90	Parallel cord	●	●	●	—	IC circuit	Relay PLC
					5V, 12V, 100V	5V, 12V, 24V, 100V	90A	Heavy-duty cord	●	●	●	—		
					—	—	97	Parallel cord	●	●	●	—		
					—	100V	93A	Heavy-duty cord	●	●	●	—		
					—	—	T99		●	●	—	—		
	Solid state	Grommet	Yes	3-wire (NPN)	—	—	—	Heavy-duty cord	●	●	—	—	IC circuit	Relay PLC
									●	●	—	—		
									●	●	—	—		
									●	●	—	—		
									●	●	—	—		
For 20, 30, and 40	Reed	Grommet	Yes	2-wire	24V	—	100V	Heavy-duty cord	●	●	—	—	IC circuit	Relay PLC
									●	●	●	●		
									●	●	—	—		
									●	●	—	—		
									●	●	—	—		
	Solid state	Grommet	No	3-wire (NPN)	—	—	—	Heavy-duty cord	●	●	—	—	IC circuit	Relay PLC
									●	●	—	—		
									●	●	—	—		
									●	●	—	—		
									●	●	—	—		
Solid state	Grommet	Yes	3-wire (PNP)	—	—	—	Heavy-duty cord	●	●	—	—	IC circuit	Relay PLC	
								●	●	—	—			
								●	●	—	—			
								●	●	—	—			
								●	●	—	—			

* Lead wire length symbol 0.5m Nil (Example) R73C 5m Z (Example) R73CZ
3m L (Example) R73CL None N (Example) R73CN

Construction: 10, 15, 20, 30, 40

Single vane/Double vane type
With angle adjuster

CRBU2W10, 15, 20, 30, 40-□^S_D

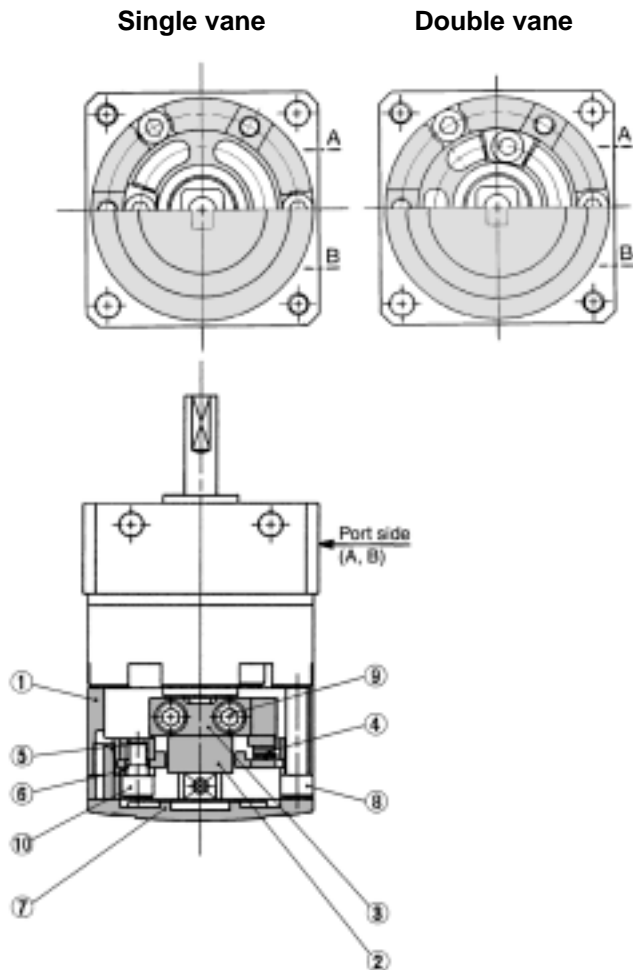

Parts list

No.	Description	Material	Note
1	Stopper ring	Die-cast aluminum	
2	Stopper lever	Carbon steel	
3	Lever retainer	Carbon steel	Zinc chromated
4	Rubber bumper	NBR	
5	Stopper block	Carbon steel	Zinc chromated
6	Block retainer	Carbon steel	Zinc chromated
7	Cap	Resin	
8	Hexagon socket head cap screw	Stainless steel	Special screw
9	Hexagon socket head cap screw	Stainless steel	Special screw
10	Hexagon socket head cap screw	Stainless steel	Special screw
11	Joint	Aluminum alloy	See note below.
12	Hexagon socket head set screw	Stainless steel	Hexagon nut will be used for CDRBU2W10 only.
	Hexagon nut	Stainless steel	
13	Round head Phillips screw	Stainless steel	See note below.
14	Magnet lever	—	See note below.

Note) These items (No. 11, 13, and 14) consist of auto switch unit and angle adjuster. Refer to pages 84 and 85 for detailed specifications.
Stainless steel is used for size 10 only.

With angle adjuster + Auto switch unit

CDRBU2WU10, 15-□^S_D CDRBU2WU20, 30, 40-□^S_D

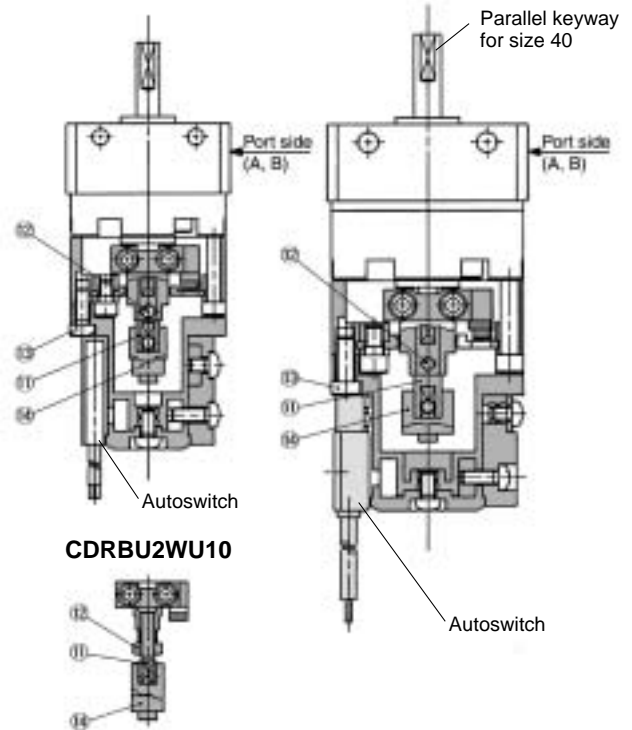

- **For single vane type:**
Illustrations above show actuators for 90° and 180° when B port is pressurized.
- **For double vane type:**
Illustrations above show the intermediate rotation position when A or B port is pressurized.

! Specific Product Precautions

Be sure to read before handling.
Refer to pages 104 through 110 for safety instructions, actuator precautions, and auto switch precautions.

Angle Adjuster

! Caution

1. Since the maximum angle of the rotation adjustment range will be limited by the rotation of the rotary actuator itself, make sure to take this into consideration when ordering.

Rotation of the rotary actuator	Rotation adjustment range
270° ⁺⁴ ₀	0° to 230° (Sizes: 10, 40)*
	0° to 240° (Sizes: 15, 20, 30)
180° ⁺⁴ ₀	0° to 175°
90° ⁺⁴ ₀	0° to 85°

* The maximum adjustment angle of the angle adjuster for size 10 and 40 is 230°.

2. Connecting ports are side ports only.
3. The allowable kinetic energy is the same as the specifications of the rotary actuator by itself (i.e., without angle adjuster).
4. Use a 100° rotary actuator if you desire to adjust the angle to 90° using a double vane type.

Free-Mounting Type **CRBU2**
CRB1

Series CRBU2WU

Dimensions: 10, 15, 20, 30 (with Angle Adjuster)

Single vane type

CRBU2WU10, 15, 20, 30-□S

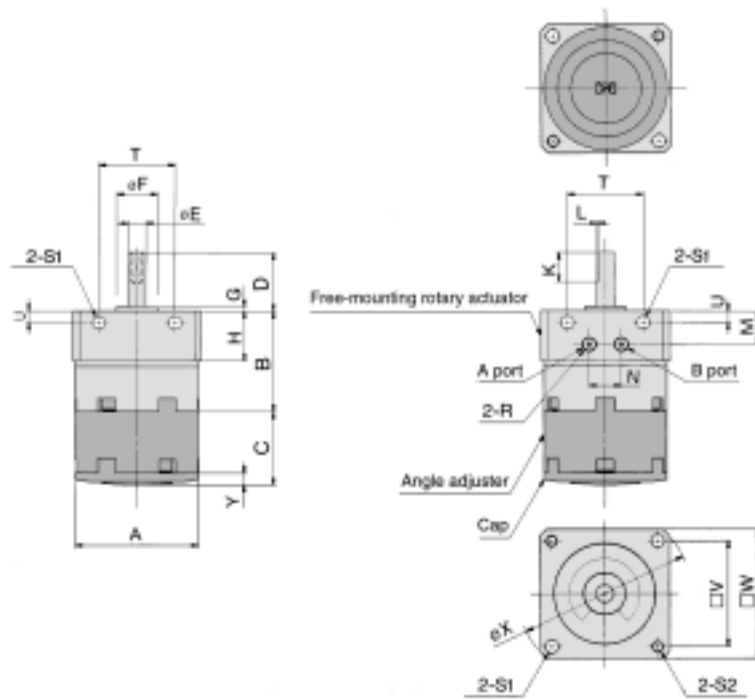

* Illustrations above show actuators for 90° and 180° when B port is pressurized, and they show size 20 actuators.

Model	A	B	C	D	E (g6)	F (h9)	G	H	K	L	M	N	R	S1	S2	T	U	V	W	X	Y
CRBU2WU10-□S	29	22	19.5	14	4 ^{+0.004} _{-0.012}	9 ⁰ _{-0.036}	1	15.5	9	0.5	10.5	10.5	M5	3.5	M3	17	3	25	31	41	3
CRBU2WU15-□S	34	25	21.2	18	5 ^{+0.004} _{-0.012}	12 ⁰ _{-0.043}	1.5	15.5	10	0.5	10.5	10.5	M5	3.5	M3	21	3	29	36	48	3.2
CRBU2WU20-□S	42	34.5	25	20	6 ^{+0.004} _{-0.012}	14 ⁰ _{-0.043}	1.5	17	10	0.5	11.5	11	M5	4.5	M4	26	4	36	44	59	4
CRBU2WU30-□S	50	47.5	29	22	8 ^{+0.005} _{-0.014}	16 ⁰ _{-0.043}	2	17.5	12	1	12	13	M5	5.5	M5	29	4.5	42	52	69	4.5

Double vane type

CRBU2WU10-□D

CRBU2WU15, 20, 30-□D

Illustrations below show size 20 actuators.

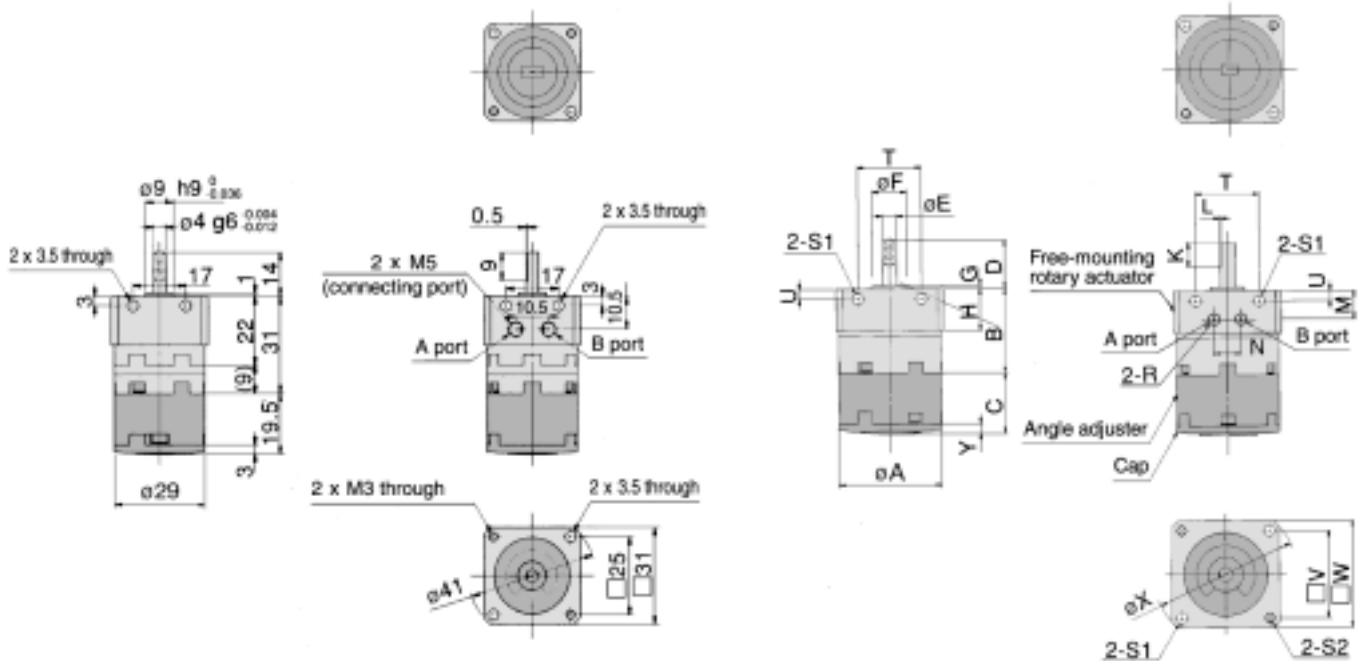

* Illustrations above show the intermediate rotation position when A or B port is pressurized.

Model	A	B	C	D	E (g6)	F (h9)	G	H	K	L	M	N	R	S1	S2	T	U	V	W	X	Y
CRBU2WU15-□D	34	25	21.2	18	5 ^{+0.004} _{-0.012}	12 ⁰ _{-0.043}	1.5	15.5	10	0.5	10.5	10.5	M5	3.5	M3	21	3	29	36	48	3.2
CRBU2WU20-□D	42	34.5	25	20	6 ^{+0.004} _{-0.012}	14 ⁰ _{-0.043}	1.5	17	10	0.5	11.5	11	M5	4.5	M4	26	4	36	44	59	4
CRBU2WU30-□D	50	47.5	29	22	8 ^{+0.005} _{-0.014}	16 ⁰ _{-0.043}	2	17.5	12	1	12	13	M5	5.5	M5	29	4.5	42	52	69	4.5

Dimensions: 40 (with Angle Adjuster)

Single vane/Double vane type
CRBU2WU40-□S, D

Keyway dimensions			
Model	b (h9)	h (h9)	L
CRBU2WU40-□□□	$4^{0}_{-0.030}$	$4^{0}_{-0.030}$	20

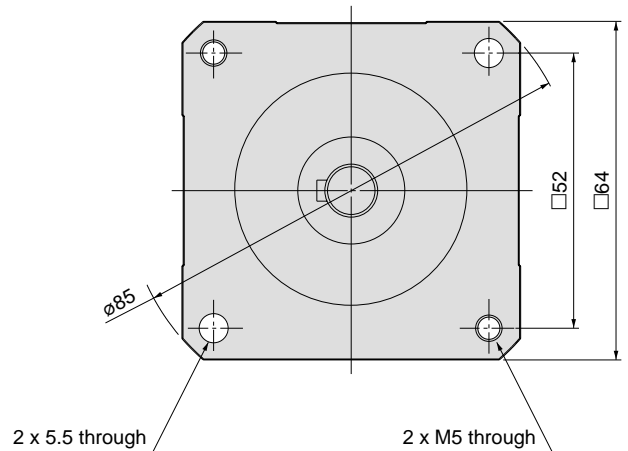
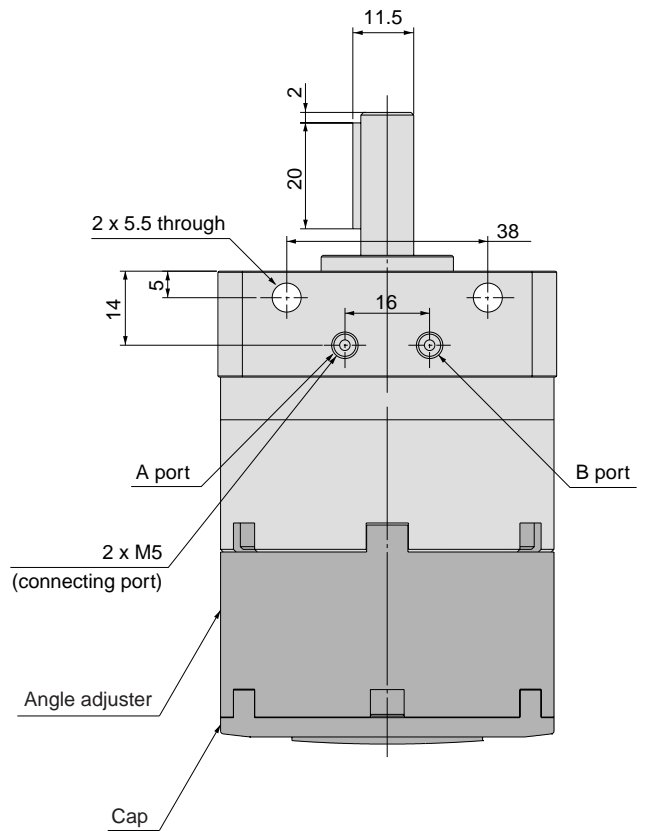
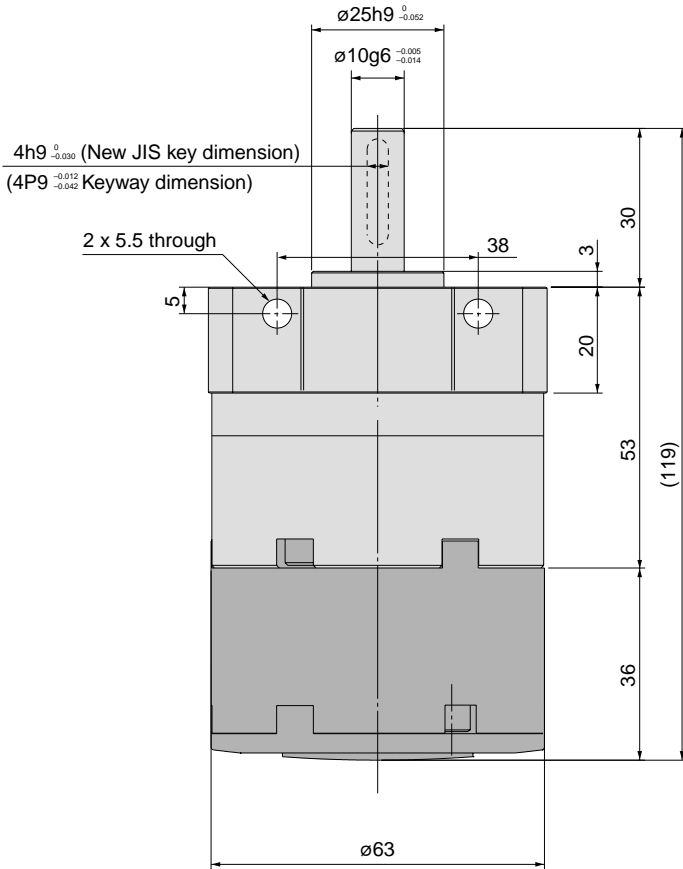
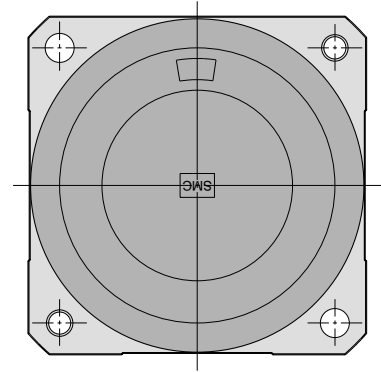

CRB2

Free-Mounting Type
CRBU2

CRB1

Series CDRBU2WU

Dimensions: 10, 15, 20, 30 (with Angle Adjuster and Auto Switch Unit)

Single vane type

CDRBU2WU10, 15-□S

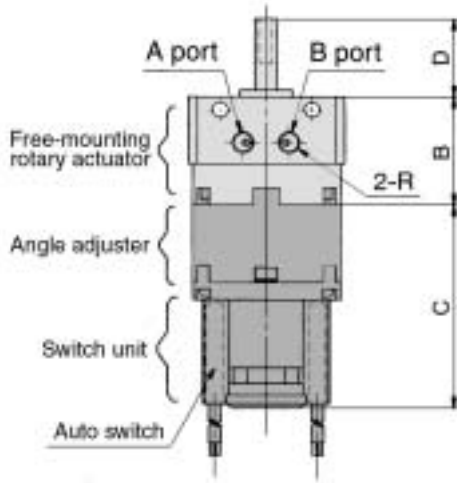

CDRBU2WU20, 30-□S

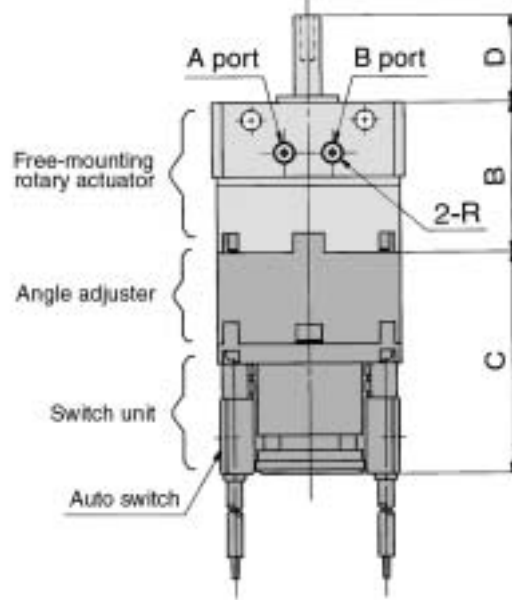

Model	B	C	D	R
CDRBU2WU10-□S	22	45.5	14	M5
CDRBU2WU15-□S	25	47	18	M5
CDRBU2WU20-□S	34.5	51	20	M5
CDRBU2WU30-□S	47.5	55.5	22	M5



* Following illustrations show actuators for 90° and 180° when A port is pressurized.

- Notes
- For rotary actuators with angle adjuster and auto switch unit, connecting ports are side ports only.
 - The above exterior view drawings illustrate the rotary actuator equipped with one right-hand and one left-hand switches.

Double vane type

CDRBU2WU10, 15-□D

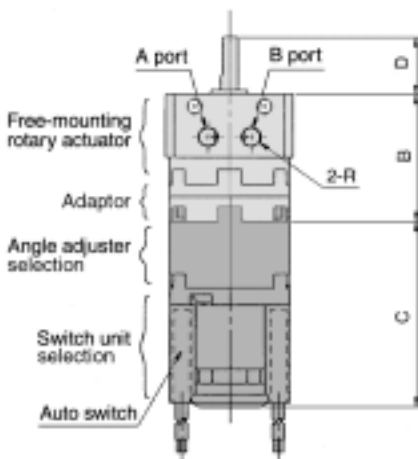

CDRBU2WU20, 30-□D

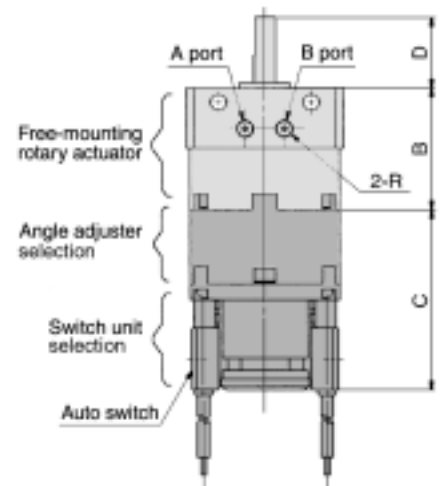
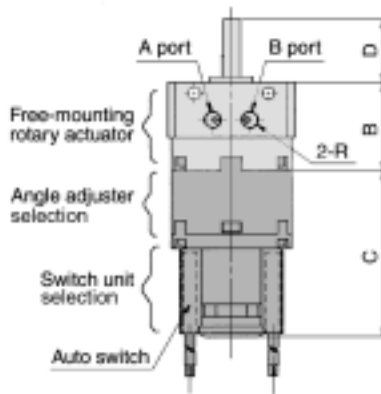

Model	B	C	D	R
CDRBU2WU10-□D	31	45.5	14	M5
CDRBU2WU15-□D	25	47	18	M5
CDRBU2WU20-□D	34.5	51	20	M5
CDRBU2WU30-□D	47.5	55.5	22	M5



* Illustrations above show the intermediate rotation position when A or B port is pressurized.

- Notes
- For rotary actuators with angle adjuster and auto switch unit, connecting ports are side ports only.
 - The above exterior view drawings illustrate the rotary actuator equipped with one right-hand and one left-hand switches.

Dimensions: 40 (with Angle Adjuster and Auto Switch Unit)

Single vane/Double vane type
CDRBU2WU40-□S, D

Keyway dimensions			
	Model	b (h9)	h (h9)
CDRBU2WU40-□□□	4 ⁰ _{-0.030}	4 ⁰ _{-0.030}	20

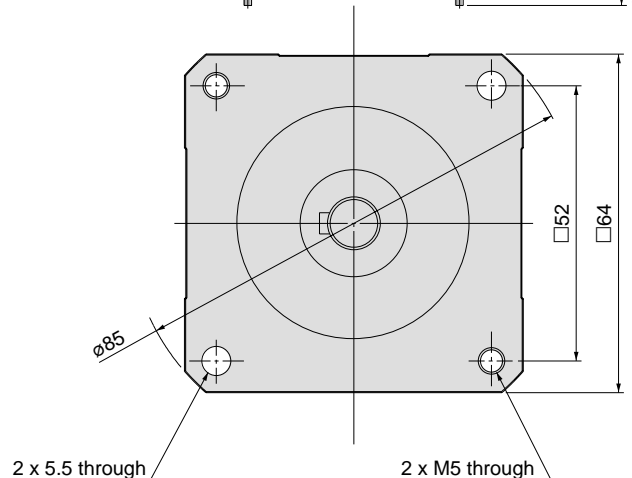
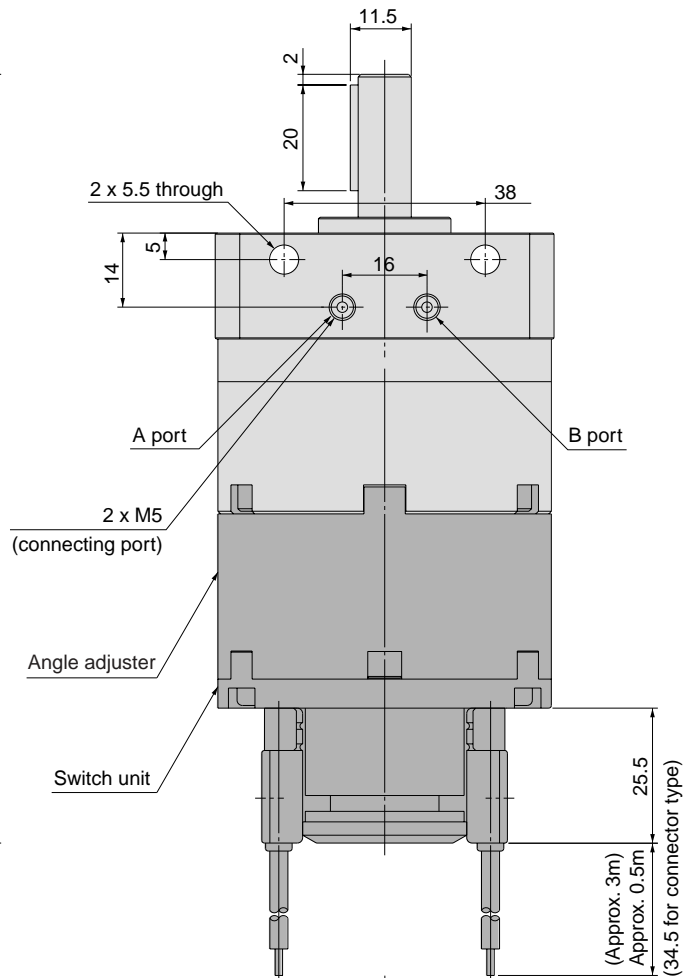
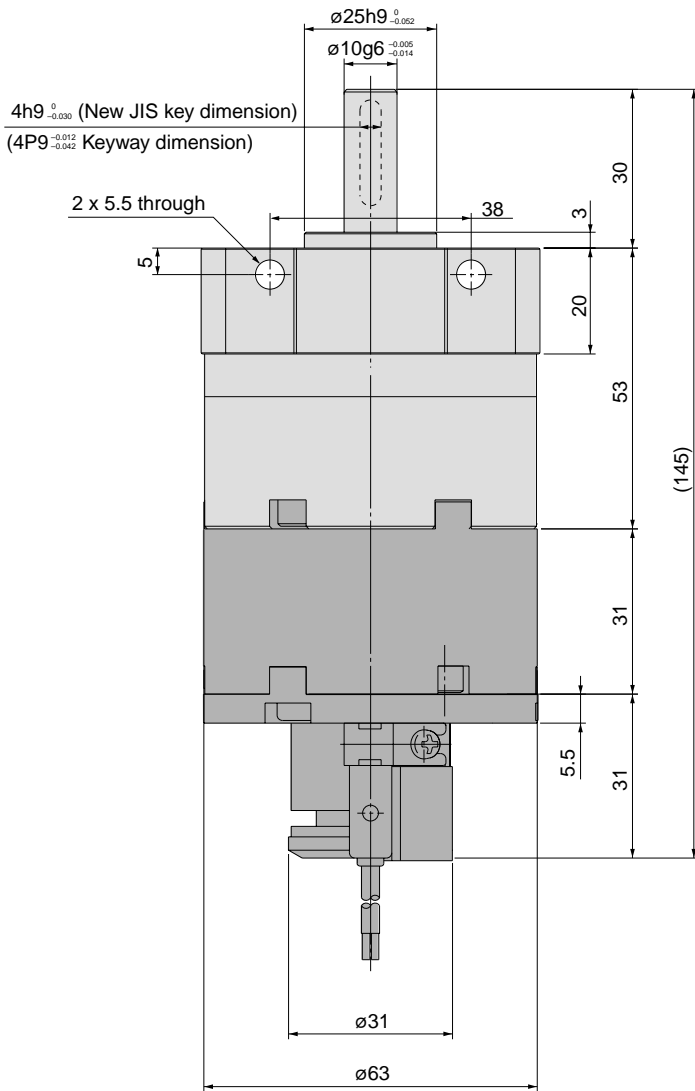
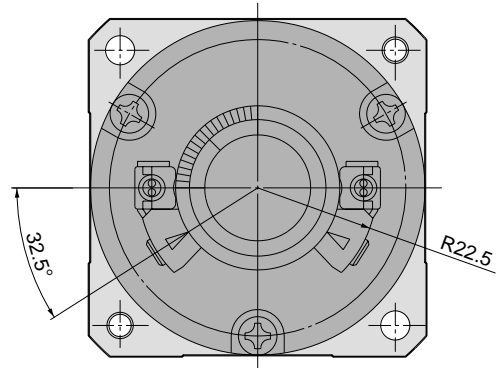

CRB2

Free-Mounting Type
CRBU2

CRB1

Series CRBU2 (Sizes: 10, 15, 20, 30, 40)

Simple Specials

-XA1 to -XA24: Shaft Pattern Sequencing 1

Simple Specials System (a system for Made to Order) will be used for Shaft Pattern Sequencing (for ordering). (Refer to Features 3.) Please contact SMC for a specification sheet when placing an order.

Shaft Pattern Sequencing 1

-XA1 to XA24

Applicable shaft type: W (Standard)

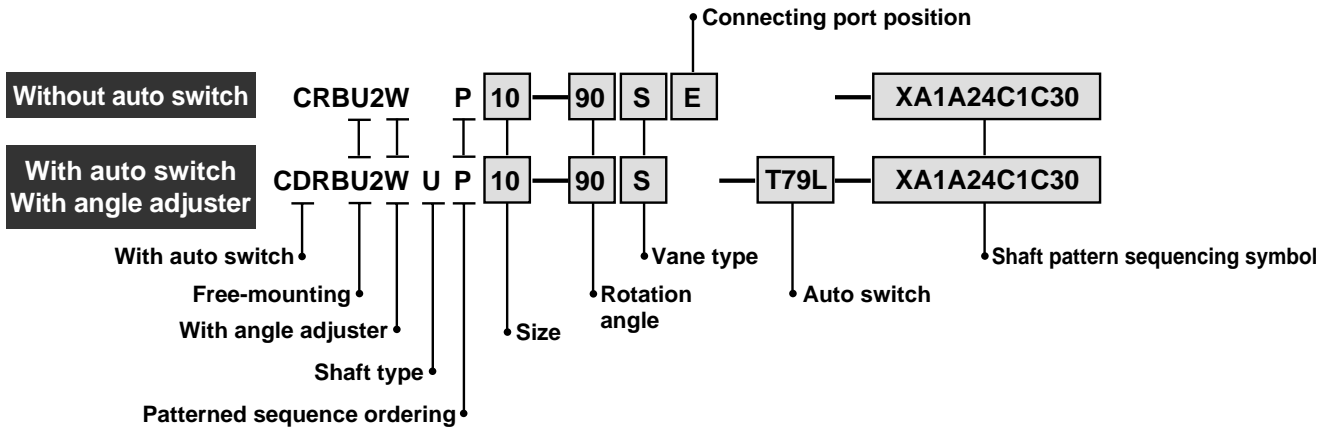

Shaft Pattern Sequencing Symbols

• Axial: Top (long-shaft side)

Symbol	Description	Applicable sizes				
		10	15	20	30	40
XA1	Shaft-end female threads	●	●	●	●	
XA3	Shaft-end male threads	●	●	●	●	
XA5	Stepped round shaft	●	●	●	●	
XA7	Stepped round shaft with female threads	●	●	●	●	
XA9	Modified length of standard chamfer	●	●	●	●	
XA11	Two-sided chamfer	●				
XA14*	Shaft through hole + Shaft-end female threads		●	●	●	●
XA17	Shortened shaft	●	●	●	●	
XA21	Round shaft with steps and two-sided chamfer	●	●	●	●	
XA23	Right-angle chamfer	●	●	●	●	
XA24	Double key					●



* This pattern is not available for rotary actuators with auto switch unit and/or angle adjuster.

• Axial: Bottom (short-shaft side)

Symbol	Description	Applicable sizes				
		10	15	20	30	40
XA2*	Shaft-end female threads		●	●	●	●
XA4*	Shaft-end male threads	●	●	●	●	●
XA6*	Stepped round shaft	●	●	●	●	●
XA8*	Stepped round shaft with male threads	●	●	●	●	●
XA10*	Modified length of standard chamfer	●	●	●	●	●
XA12*	Two-sided chamfer	●	●	●	●	●
XA15*	Shaft through hole + Shaft-end female thread		●	●	●	●
XA18*	Shortened shaft	●	●	●	●	●
XA22*	Stepped round shaft with double-sided chamfer	●	●	●	●	●

• Double shaft

Symbol	Description	Applicable sizes				
		10	15	20	30	40
XA13*	Shaft through hole		●	●	●	●
XA16*	Shaft through hole + Double shaft-end female threads		●	●	●	●
XA19	Shortened shaft	●	●	●	●	
XA20	Reversed shaft	●	●	●	●	●

Combinations

XA□ combinations

Symbol	Combination																								
XA1	XA1																								
XA2	●	XA2																							
XA3	—	●	XA3																						
XA4	●	—	●	XA4																					
XA5	—	●	—	●	XA5																				
XA6	●	—	●	—	●	XA6																			
XA7	—	●	—	●	—	●	XA7																		
XA8	●	—	●	—	●	—	●	XA8																	
XA9	—	●	—	●	—	●	—	●	XA9																
XA10	●	—	●	—	●	—	●	—	●	XA10															
XA11	—	●	—	●	—	●	—	●	—	●	XA11														
XA12	●	—	●	—	●	—	●	—	●	—	●	XA12													
XA13	—	●	—	●	—	●	—	●	—	●	—	●	XA13												
XA14	—	—	—	—	—	—	—	—	—	—	—	—	●	●	—	—	—	—	—	—	—	—	—	—	
XA15	—	—	—	—	—	—	—	—	—	—	—	—	—	—	—	—	—	—	—	—	—	—	—	—	—
XA16	—	—	—	—	—	—	—	—	—	—	—	—	—	—	—	—	—	—	—	—	—	—	—	—	—
XA17	—	●	—	●	—	●	—	●	—	●	—	●	—	●	—	●	—	●	—	●	—	●	—	●	—
XA18	●	—	●	—	●	—	●	—	●	—	●	—	●	—	●	—	●	—	●	—	●	—	●	—	●
XA19	—	—	—	—	—	—	—	—	—	—	—	—	—	—	—	—	—	—	—	—	—	—	—	—	—
XA20	—	—	—	—	—	—	—	—	—	—	—	—	—	—	—	—	—	—	—	—	—	—	—	—	—
XA21	—	●	—	●	—	●	—	●	—	●	—	●	—	●	—	●	—	●	—	●	—	●	—	●	—
XA22	●	—	●	—	●	—	●	—	●	—	●	—	●	—	●	—	●	—	●	—	●	—	●	—	●
XA23	—	●	—	●	—	●	—	●	—	●	—	●	—	●	—	●	—	●	—	●	—	●	—	●	—
XA24	—	●	—	●	—	●	—	●	—	●	—	●	—	●	—	●	—	●	—	●	—	●	—	●	—

Combination

●	Available
—	Not available

A combination of up to two XA□s are available.
Example: -XA1A24

XA□, XC□ combinations

Combination other than -XA□, such as Made to Order (-XC□), is also available.
Refer to pages 63 and 64 for detailed description of Made to Order.

Symbol	Description	Applicable sizes	Combination XA1 to XA24
XC1*	Add connecting port	10, 15, 20, 30, 40	●
XC2*	Change threads to through hole	15, 20, 30, 40	●
XC3*	Change a screw position	10, 15, 20, 30, 40	●
XC4	Change rotation range		●
XC5	Change rotation range between 0° to 200°		●
XC6	Change rotation range between 0° to 110°		●
XC7*	Reversed shaft		—
XC30	Fluorine grease		●



* These specifications are not available for rotary actuators with auto switch unit and/or angle adjuster.
A total of four XA□ and XC□ combinations is available.
Examples: -XA1A2C1C30
-XA2C1C4C30

Axial: Top (Long-shaft side)

Symbol: A1

The long shaft can be further shortened by machining female threads into it. (If shortening the shaft is not required, indicate "*" for dimension X.)

- Not available for size 10.
- The maximum dimension L1 is, as a rule, twice the thread size.

(Example) For M3: L1 = 6mm

- Applicable shaft type: W

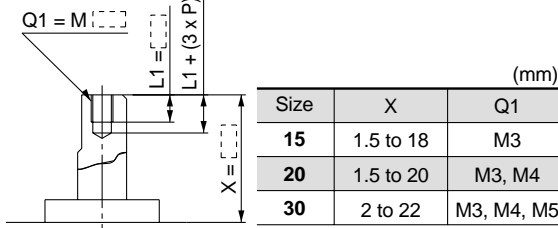

Symbol: A3

The long shaft can be further shortened by machining male threads into it. (If shortening the shaft is not required, indicate "*" for dimension X.)

- Applicable shaft type: W

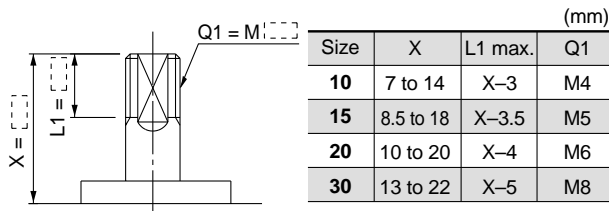

Symbol: A5

The long shaft can be further shortened by machining it into a stepped round shaft. (If shortening the shaft is not required, indicate "*" for dimension X.)

- Applicable shaft type: W
 - Equal dimensions are indicated by the same marker.
- (If not specifying dimension C1, indicate "*" instead.)

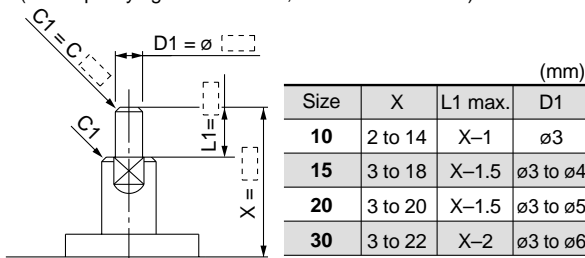

Symbol: A7

The long shaft can be further shortened by machining it into a stepped round shaft with male threads. (If a shortening of the shaft is not required, indicate "*" for dimension X.)

- Applicable shaft type: W
 - Equal dimensions are indicated by the same marker.
- (If not specifying dimension C1, indicate "*" instead.)

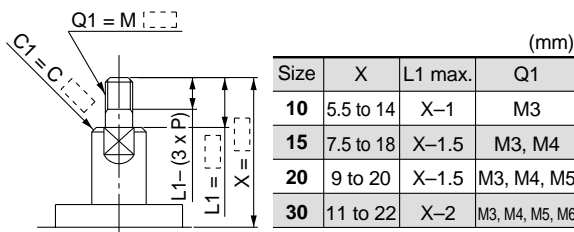

Axial: Bottom (Short-shaft side)

Symbol: A2

The short shaft can be further shortened by machining female threads into it. (If shortening the shaft is not required, indicate "*" for dimension Y.)

- Not available for size 10.
- The maximum dimension L2 is, as a rule, twice the thread size.

(Example) For M3: L2 = 6mm

- Applicable shaft type: W

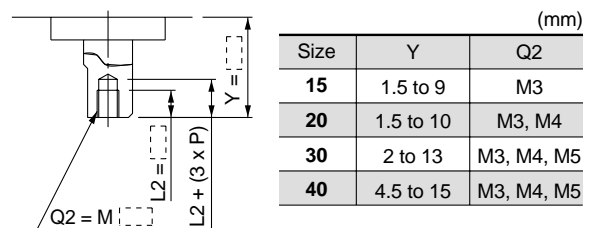

Symbol: A4

The short shaft can be further shortened by machining male threads into it. (If shortening the shaft is not required, indicate "*" for dimension Y.)

- Applicable shaft type: W

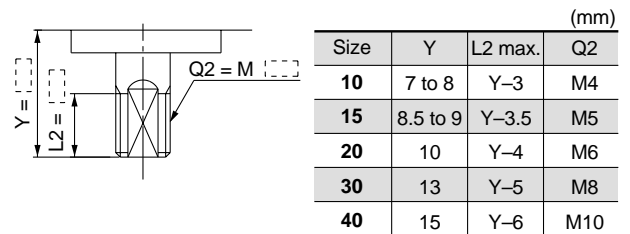

Symbol: A6

The short shaft can be further shortened by machining it into a stepped round shaft. (If shortening the shaft is not required, indicate "*" for dimension Y.)

- Applicable shaft type: W
 - Equal dimensions are indicated by the same marker.
- (If not specifying dimension C2, indicate "*" instead.)

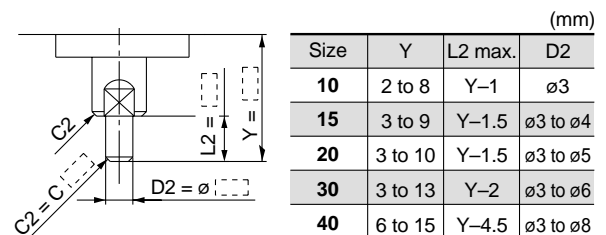

Symbol: A8

The short shaft can be further shortened by machining it into a stepped round shaft with male threads. (If shortening the shaft is not required, indicate "*" for dimension Y.)

- Applicable shaft type: W
 - Equal dimensions are indicated by the same marker.
- (If not specifying dimension C2, indicate "*" instead.)

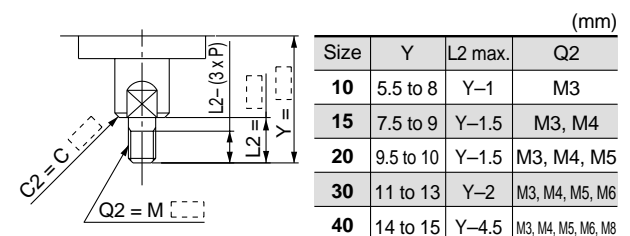

Axial: Top (Long-shaft side)

Symbol: A9 The long shaft can be further shortened by changing the length of the standard chamfer on the long shaft side. (If shortening the shaft is not required, indicate "*" for dimension X.)

- Applicable shaft type: W

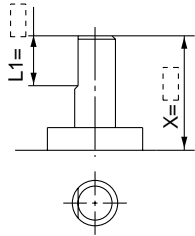

Size	X	L1
10	3 to 14	9-(14-X) to (X-1)
15	5.5 to 18	10-(18-X) to (X-1.5)
20	7 to 20	10-(20-X) to (X-1.5)
30	7 to 22	10-(22-X) to (X-1.5)

Symbol: A11 The long shaft can be further shortened by machining a double-sided chamfer onto it. (If altering the standard chamfer and shortening the shaft are not required, indicate "*" for both the L1 and X dimensions.)

- Since L1 is a standard chamfer, dimension E1 is 0.5mm or more, and 1mm or more with a shaft bore size of $\phi 30$.
- Applicable shaft type: W

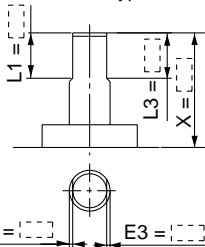

Size	X	L1	L3 max.
10	3 to 14	9-(14-X) to (X-1)	X-1
15	3 to 18	10-(18-X) to (X-1.5)	X-1.5
20	3 to 20	10-(20-X) to (X-1.5)	X-1.5
30	5 to 22	12-(22-X) to (X-2)	X-2

Symbol: A14 Applicable to single vane type only
A special end is machined onto the long shaft, and a through hole is drilled into it. Female threads are machined into the through hole, whose diameter is equivalent to the pilot hole diameter.

- Not available for size 10.
- The maximum L1 dimension is, as a rule, twice the thread size. (Example) For M3: L1 = 6mm
- A parallel keyway is used on the long shaft for size 40.
- Applicable shaft type: W

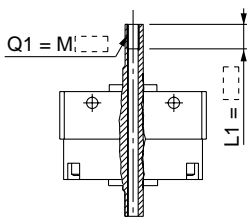

Thread	Size	15	20	30	40
M3		$\phi 2.5$	$\phi 2.5$	$\phi 2.5$	$\phi 2.5$
M4		—	$\phi 3.3$	$\phi 3.3$	—
M5		—	—	$\phi 4.2$	—

Symbol: A17 Shorten the long shaft.

- Applicable shaft type: W

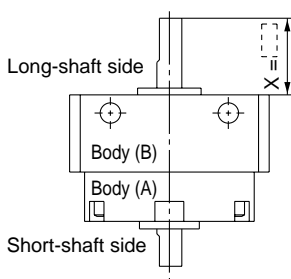

Size	X
10	1 to 14
15	1.5 to 18
20	1.5 to 20
30	2 to 22

Axial: Bottom (Short-shaft side)

Symbol: A10 The short shaft can be further shortened by changing the length of the standard chamfer. (If shortening the shaft is not required, indicate "*" for dimension Y.)

- Applicable shaft type: W

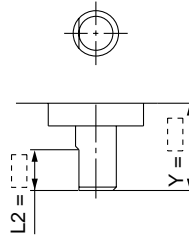

Size	Y	L2
10	3 to 8	5-(8-Y) to (Y-1)
15	3 to 9	6-(9-Y) to (Y-1.5)
20	3 to 10	7-(10-Y) to (Y-1.5)
30	5 to 13	8-(13-Y) to (Y-2)
40	7 to 15	9-(15-Y) to (Y-4.5)

Symbol: A12 The short shaft can be further shortened by machining a double-sided chamfer onto it. (If altering the standard chamfer and shortening the shaft are not required, indicate "*" for both the L2 and Y dimensions.)

- Since L2 is a standard chamfer, dimension E2 is 0.5mm or more, and 1mm or more with shaft bore sizes of $\phi 30$ or $\phi 40$.
- Applicable shaft type: W

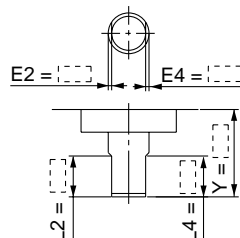

Size	Y	L2	L2 max.
10	3 to 8	5-(8-Y) to (Y-1)	Y-1
15	3 to 9	6-(9-Y) to (Y-1.5)	Y-1.5
20	3 to 10	7-(10-Y) to (Y-1.5)	Y-1.5
30	5 to 13	8-(13-Y) to (Y-2)	Y-2
40	7 to 15	9-(15-Y) to (Y-4.5)	Y-4.5

Symbol: A15 Applicable to single vane type only
A special end is machined onto the short shaft, and a through hole is drilled into it. Female threads are machined into the through hole, whose diameter is equivalent to the pilot hole diameter.

- Not available for size 10.
- The maximum L2 dimension is, as a rule, twice the thread size. (Example) For M4: L2 = 8mm
- A parallel keyway is used on the long shaft for size 40.
- Applicable shaft type: W

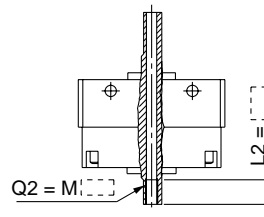

Thread	Size	15	20	30	40
M3		$\phi 2.5$	$\phi 2.5$	$\phi 2.5$	$\phi 2.5$
M4		—	$\phi 3.3$	$\phi 3.3$	—
M5		—	—	$\phi 4.2$	—

Symbol: A18 Shorten the short shaft.

- A parallel keyway is used on the long shaft for size 40.
- Applicable shaft type: W

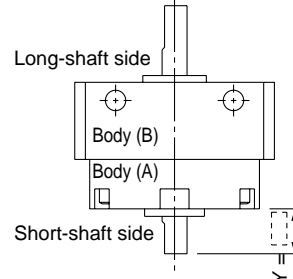

Size	Y
10	1 to 8
15	1.5 to 9
20	1.5 to 10
30	2 to 13
40	4.5 to 15

Series CRBU2

Axial: Top (Long-shaft side)

Symbol: A21

The long shaft can be further shortened by machining it into a stepped round shaft with a double-sided chamfer. (If shortening the shaft is not required, indicate "*" for dimension X.)

- Applicable shaft type: W
- Equal dimensions are indicated by the same marker. (If not specifying dimension C1, indicate "*" instead.)

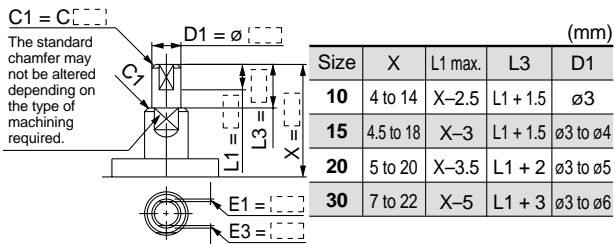

Axial: Bottom (Short-shaft side)

Symbol: A22

The short shaft can be further shortened by machining it into a stepped round shaft with a double-sided chamfer. (If shortening the shaft is not required, indicate "*" for dimension Y.)

- Applicable shaft type: W
- Equal dimensions are indicated by the same marker. (If not specifying dimension C2, indicate "*" instead.)

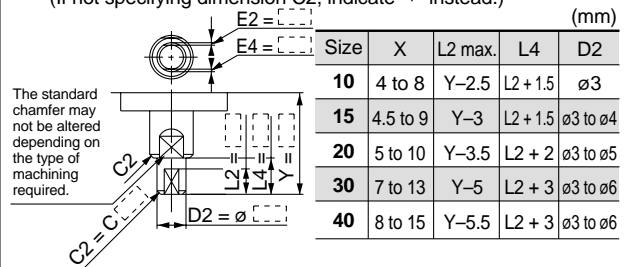

Double shaft

Symbol: A13

Applicable to single vane type only

- Shaft with through hole
- Not available for size 10.
- Minimum machining diameter for d1 is 0.1mm.
- A parallel keyway is used on the long shaft for size 40.

- Applicable shaft type: W
- Equal dimensions are indicated by the same marker. (If not specifying dimension C1, indicate "*" instead.)

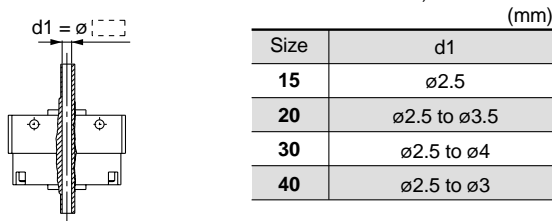

Symbol: A16

Applicable to single vane type only

A special end is machined onto both the long and short shafts, and a through hole is drilled into both shafts. Female threads are machined into the through holes, whose diameter is equivalent to the diameter of the pilot holes.

- Not available for size 10.
- The maximum L1 dimension is, as a rule, twice the thread size. (Example) For M5: L1 = 10mm
- A parallel keyway is used on the long shaft for size 40.
- Applicable shaft type: W
- Equal dimensions are indicated by the same marker.

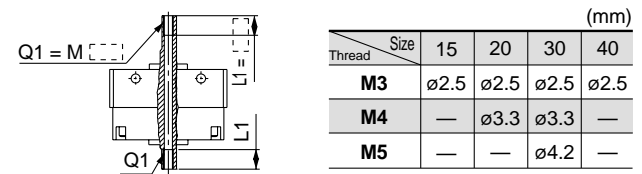

Symbol: A19

Both the long shaft and short shaft are shortened.

- A parallel keyway is used on the long shaft for size 40.
- Applicable shaft type: W

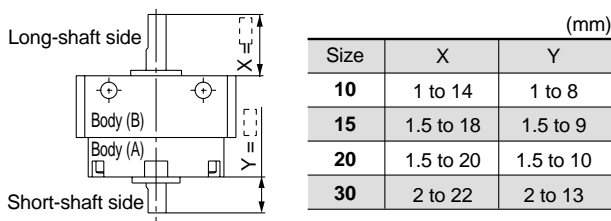

Symbol: A20

The rotation axis is reversed.

- (The long shaft and short shaft are shortened.)
- A parallel keyway is used on the long shaft for size 40.
- Applicable shaft type: W

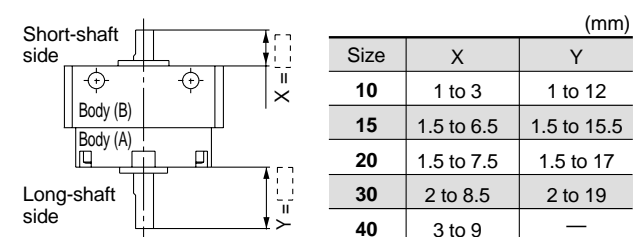

Symbol: A23

The long shaft can be further shortened by machining right-angle double-sided chamfer onto it. (If altering the standard chamfer and shortening the shaft are not required, indicate "*" for both the L1 and X dimensions.)

- Since L1 is a standard chamfer, dimension E1 is 0.5mm or more, and 1mm or more with a shaft bore sizes of ø30 or ø40.
- Applicable shaft type: W

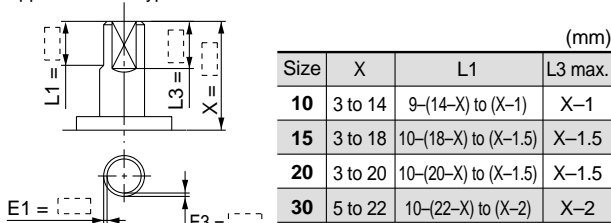

Symbol: A24

Double key

Keys and keyways are machined at 180° from the standard position.

- Applicable shaft type: W
- Equal dimensions are indicated by the same marker.

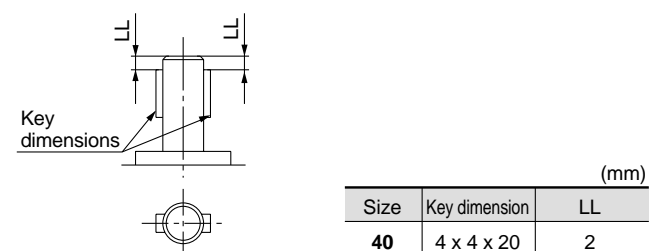

CRB2

Free-Mounting Type
CRBU2

CRB1

Series CRBU2 (Sizes: 10, 15, 20, 30, 40)

Simple Specials

-XA31 to -XA47: Shaft Pattern Sequencing 2

Simple Specials System (a system for Made to Order) will be used for Shaft Pattern Sequencing (for ordering). (Refer to Features 3.) Please contact SMC for a specification sheet when placing an order.

Shaft Pattern Sequencing 2

-XA31 to XA47

Applicable shaft types: J, K, S, T, Y

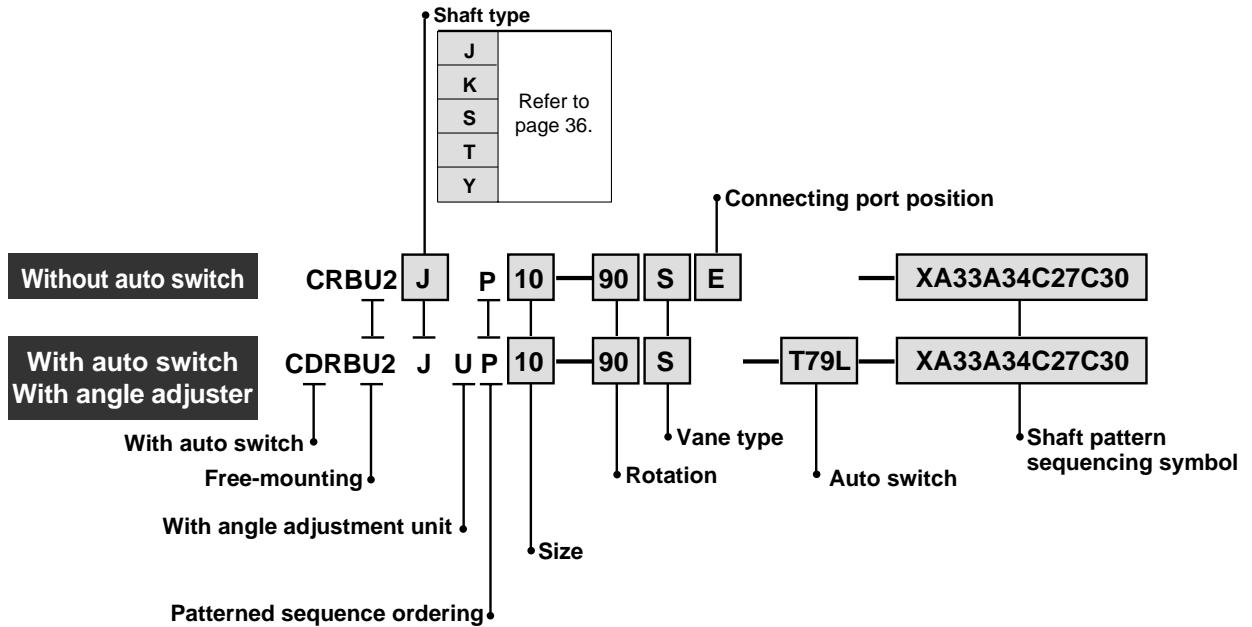

Shaft Pattern Sequencing Symbols

• Axial: Top (long-shaft side)

Symbol	Description	Shaft type	Applicable sizes				
			10	15	20	30	40
XA31	Shaft-end female threads	S, Y	●	●	●	●	●
XA33	Shaft-end female threads	J, K, T	●	●	●	●	●
XA37	Stepped round shaft	J, K, T	●	●	●	●	●
XA45	Middle-cut chamfer	J, K, T	●	●	●	●	●
XA47	Machined keyway	J, K, T			●	●	

• Axial: Bottom (short-shaft side)

Symbol	Description	Shaft type	Applicable sizes				
			10	15	20	30	40
XA32*	Shaft-end female threads	S, Y		●	●	●	●
XA34*	Shaft-end female threads	J, K, T		●	●	●	●
XA38*	Stepped round shaft	K	●	●	●	●	●
XA46*	Middle-cut chamfer	K	●	●	●	●	●

• Double shaft

Symbol	Description	Shaft type	Applicable sizes				
			10	15	20	30	40
XA39*	Shaft through hole	S, Y		●	●	●	●
XA40*	Shaft through hole	K, T		●	●	●	●
XA41*	Shaft through hole	J		●	●	●	●
XA42*	Shaft through hole + Shaft-end female threads	S, Y		●	●	●	●
XA43*	Shaft through hole + Shaft-end female threads	K, T		●	●	●	●
XA44*	Shaft through hole + Shaft-end female threads	J		●	●	●	●



* These specifications are not available for rotary actuators with auto switch unit and/or angle adjuster.

Combinations

XA□ combinations

Symbol	Combination					
XA31	XA31					
XA32	SY	XA32				
XA33	—	JKT	XA33			
XA34	—	—	JKT	XA34		
XA37	—	—	—	JKT	XA37	
XA38	—	—	K	—	K	XA38

A combination of up to two XA□s are available.
Example: -XA31A32

XA□, XC□ combinations

Combination other than -XA□, such as Made to Order (-XC□), is also available. Refer to pages 63 and 64 for detailed description of Made to Order.

Symbol	Description	Applicable sizes	Combination XA31 to XA47
XC1*	Add connecting port	10, 15, 20, 30, 40	●
XC2*	Change threads to through hole	15, 20, 30, 40	●
XC3*	Change a screw position		●
XC4	Change rotation range		●
XC5	Change rotation range between 0° to 200°	10, 15, 20, 30, 40	●
XC6	Change rotation range between 0° to 110°		●
XC7*	Reversed shaft		—
XC30	Fluorine grease		●



* These specifications are not available for rotary actuators with auto switch unit and/or angle adjuster.
A total of four XA□ and XC□ combinations is available.
Example: -XA33A34C27C30

Axial: Top (Long-shaft side)

Symbol: A31 Machine female threads into the long shaft.

- The maximum dimension L1 is, as a rule, twice the thread size. (Example) For M3: L1 = 6mm
- Applicable shaft types: S, Y

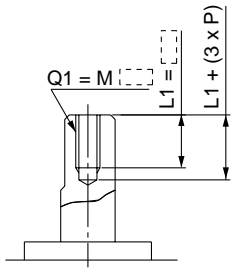

Size	Q1	
	Shaft type S	Shaft type Y
10	Not available	
15	M3	
20	M3, M4	
30	M3, M4, M5	

Symbol: A33 Machine female threads into the long shaft.

- The maximum dimension L1 is, as a rule, twice the thread size. (Example) For M3: L1 = 6mm
- Applicable shaft types: J, K, T

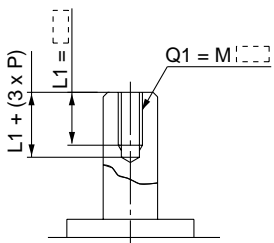

Size	Q1		
	Shaft type J	Shaft type K	Shaft type T
10	Not available		
15	M3		
20	M3, M4		
30	M3, M4, M5		
40	M3, M4, M5		

Symbol: A37 The long shaft can be further shortened by machining it into a stepped round shaft. (If shortening the shaft is not required, indicate "*" for dimension X.)

- Applicable shaft types: J, K, T
- Equal dimensions are indicated by the same marker. (If not specifying dimension C1, indicate "*" instead.)

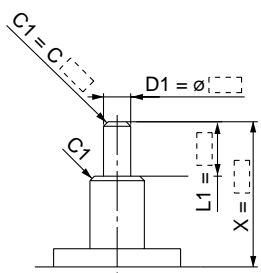

Size	X	L1 max.	D1	
			Y	Z
10	2 to 14	X-1	ø3 to ø3.9	
15	3 to 18	X-1.5	ø3 to ø4.9	
20	3 to 20	X-1.5	ø3 to ø5.9	
30	3 to 22	X-2	ø3 to ø7.9	
40	4 to 30	X-3	ø3 to ø9.9	

Symbol: A45 The long shaft can be further shortened by machining a middle-cut chamfer into it. (The position of the chamfer is same as the standard one.) (If shortening the shaft is not required, indicate "*" for dimension X.)

- Applicable shaft types: J, K, T

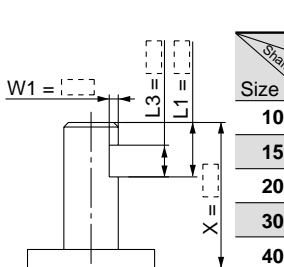

Size	X			W1			L1 max.			L3 max.		
	Shaft type J	Shaft type K	Shaft type T	Shaft type J	Shaft type K	Shaft type T	Shaft type J	Shaft type K	Shaft type T	Shaft type J	Shaft type K	Shaft type T
10	6.5 to 14			0.5 to 2			X-3			L1-1		
15	8 to 18			0.5 to 2.5			X-4			L1-1		
20	9 to 20			0.5 to 3			X-4.5			L1-1		
30	11.5 to 22			0.5 to 4			X-5			L1-2		
40	15.5 to 30			0.5 to 5			X-5.5			L1-2		

Axial: Bottom (Short-shaft side)

Symbol: A32 Machine female threads into the short shaft.

- The maximum dimension L2 is, as a rule, twice the thread size. (Example) For M4: L2 = 8mm
- However, for M5 with S shaft, the maximum dimension L2 is 1.5 times the thread size.
- Applicable shaft types: S, Y

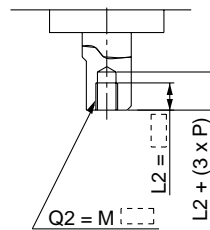

Size	Q2	
	Shaft type S	Shaft type Y
10	Not available	
15	M3	
20	M3, M4	
30	M3, M4, M5	

Symbol: A34 Machine female threads into the short shaft.

- The maximum dimension L2 is, as a rule, twice the thread size. (Example) For M3: L2 = 6mm
- However, for M5 with T shaft, the maximum dimension L2 is 1.5 times the thread size.
- Applicable shaft types: J, K, T

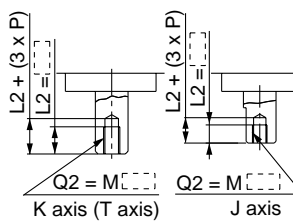

Size	Q2		
	Shaft type J	Shaft type K	Shaft type T
10	Not available		
15	M3		
20	M3, M4		
30	M3, M4, M5		
40	M3, M4, M5		

Symbol: A38 The short shaft can be further shortened by machining it into a stepped round shaft. (If shortening the shaft is not required, indicate "*" for dimension Y.)

- Applicable shaft type: K
- Equal dimensions are indicated by the same marker. (If not specifying dimension C2, indicate "*" instead.)

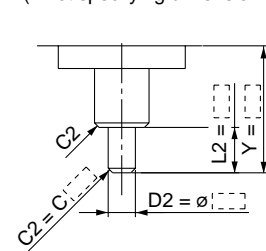

Size	Y	L2 max.	D2	
			Y	Z
10	2 to 14	Y-1	ø3 to ø3.9	
15	3 to 18	Y-1.5	ø3 to ø4.9	
20	3 to 20	Y-1.5	ø3 to ø5.9	
30	6 to 22	Y-2	ø3 to ø7.9	
40	6 to 30	Y-4.5	ø5 to ø9.9	

Symbol: A46 The short shaft can be further shortened by machining a middle-cut chamfer into it. (The position of the chamfer is same as the standard one.) (If shortening the shaft is not required, indicate "*" for dimension Y.)

- Applicable shaft type: K

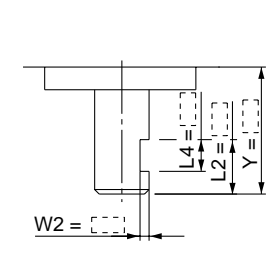

Size	Y	W2	L2 max.		L4 max.	
			Y	Z	Y	Z
10	4.5 to 14	0.5 to 2	Y-1	L2-1	L2-1	L2-1
15	5.5 to 18	0.5 to 2.5	Y-1.5	L2-1	L2-1	L2-1
20	6 to 20	0.5 to 3	Y-1.5	L2-1	L2-1	L2-1
30	8.5 to 22	0.5 to 4	Y-2	L2-2	L2-2	L2-2
40	13.5 to 30	0.5 to 5	Y-4.5	L2-2	L2-2	L2-2

Series CRBU2

Axial: Top (Long-shaft side)

Symbol: A47 Machine a keyway into the long shaft. (The position of the keyway is same as the standard one.)
The key must be ordered separately.
• Applicable shaft types: J, K, T

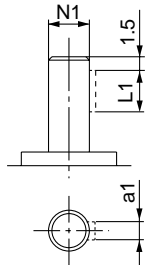

	(mm)		
Size	a1	L1	N1
20	2h _{-0.025} ⁰	10	6.8
30	3h _{-0.025} ⁰	14	9.2

Double shaft

Symbol: A39 Applicable to single vane type only
Shaft with through hole (Additional machining of S, Y shaft)
• Not available for size 10.
• Minimum machining diameter for d1 is 0.1mm.
• A parallel keyway is used on the long shaft for size 40.
• Applicable shaft types: S, Y
• Equal dimensions are indicated by the same marker.

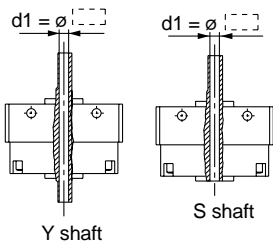

Shaft type	(mm)	
	S	Y
Size	d1	
15	ø2.5	
20	ø2.5 to ø3.5	
30	ø2.5 to ø4	
40	ø2.5 to ø5	

Symbol: A40 Applicable to single vane type only
Shaft with through hole (Additional machining of K, T shaft)
• Not available for size 10.
• d1 = ø2.5, L1 = 18 for size 15; minimum machining diameter for d1 is 0.1mm.
• d1 = d3 for sizes 20 to 40. • Applicable shaft types: K, T
• Equal dimensions are indicated by the same marker.

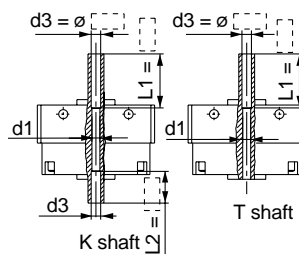

Shaft type	(mm)			
	K	T	K	T
Size	d1	d3		
15	ø2.5	ø2.5 to ø3		
20	—	ø2.5 to ø4		
30	—	ø2.5 to ø4.5		
40	—	ø2.5 to ø5		

Symbol: A41 Applicable to single vane type only
Shaft with through hole
• Not available for size 10.
• Applicable shaft type: J
• Equal dimensions are indicated by the same marker.

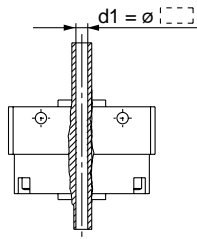

	(mm)
Size	d1
15	ø2.5
20	ø2.5 to ø3.5
30	ø2.5 to ø4
40	ø2.5 to ø4.5

Symbol: A42 Applicable to single vane type only
A special end is machined onto both the long and short shafts, and a through hole is drilled into both. Female threads are machined into the through holes, whose diameter is equivalent to the diameter of the pilot holes.
• Not available for size 10.
• The maximum L1 dimension is, in principle, twice the thread size. (Example) For M5: L1 = 10mm
However, for M5 on the short shaft of S shaft: L1 = 7.5mm
• A parallel keyway is used on the long shaft for size 40.
• Applicable shaft types: S, Y
• Equal dimensions are indicated by the same marker.

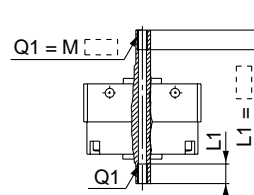

Shaft type	(mm)							
	15		20		30		40	
Size	15	20	30	40				
Thread	S	Y	S	Y	S	Y	S	Y
M3	ø2.5	ø2.5	ø2.5	ø2.5				
M4	—	ø3.3	ø3.3	—				
M5	—	—	ø4.2	—				

Symbol: A43 Applicable to single vane type only
A special end is machined onto both the long and short shafts, and a through hole is drilled into both shafts. Female threads are machined into the through holes, whose diameter is equivalent to the diameter of the pilot holes.
• Not available for size 10.
• The maximum L1 dimension is, in principle, twice the thread size. (Example) For M5: L1 = 10mm
However, for M5 on the short shaft of T shaft: L1 = 7.5mm
• Applicable shaft types: K, T
• Equal dimensions are indicated by the same marker.

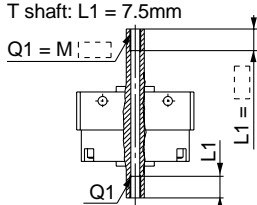

Shaft type	(mm)							
	15		20		30		40	
Size	15	20	30	40				
Thread	K	T	K	T	K	T	K	T
M3	ø2.5	ø2.5	ø2.5	ø2.5				
M4	—	ø3.3	ø3.3	ø3.3				
M5	—	—	ø4.2	ø4.2				

Symbol: A44 Applicable to single vane type only
A special end is machined onto both the long and short shafts, and a through hole is drilled into both shafts. Female threads are machined into the through holes, whose diameter is equivalent to the diameter of the pilot holes.
• Not available for size 10.
• The maximum L1 dimension is, in principle, twice the thread size. (Example) For M5: L1 = 10mm
• A parallel keyway is used on the long shaft for size 40.
• Applicable shaft type: J
• Equal dimensions are indicated by the same marker.

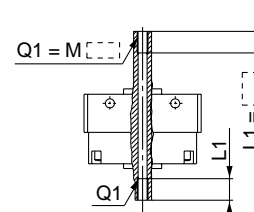

Shaft type	(mm)			
	15	20	30	40
Size	15	20	30	40
Thread	S	Y	S	Y
M3	ø2.5	ø2.5	ø2.5	ø2.5
M4	—	ø3.3	ø3.3	ø3.3
M5	—	—	ø4.2	ø4.2

Series CRBU2 (Sizes: 10, 15, 20, 30, 40)

Made to Order

XC1, 2, 3, 4, 5, 6, 7, 30

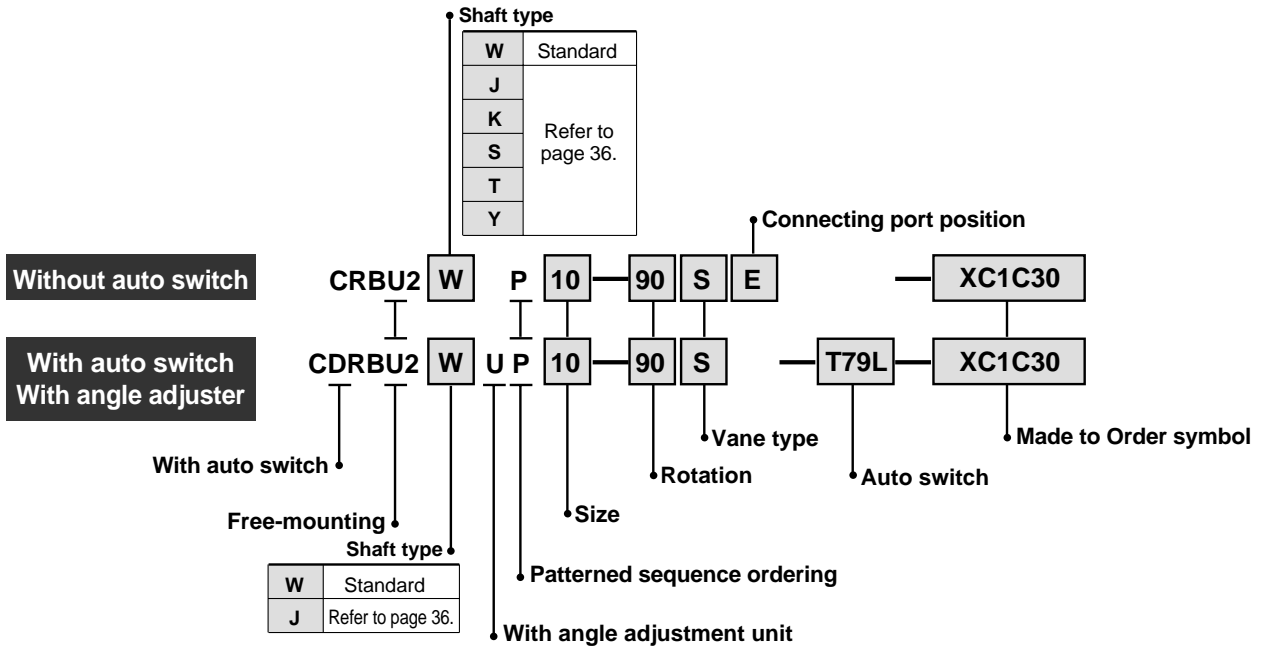

Made to Order Symbol

Symbol	Description	Applicable shaft types	Applicable sizes
		W, J, K, S, T, Y	
XC1*	Add connecting port	●	10, 15, 20, 30, 40
XC2*	Change threaded holes to through holes	●	
XC3*	Change the screw position	●	
XC4	Change rotation range and direction	●	
XC5	Change rotation range between 0° to 200°	●	
XC6	Change rotation range between 0° to 110°	●	
XC7*	Reversed shaft	W, J	
XC30	Fluorine grease	●	

* These specifications are not available for rotary actuators with auto switch unit and/or angle adjuster.

Combinations

Symbol	Combination						
XC1	XC1						
XC2	●	XC2					
XC3	●	—	XC3				
XC4	●	●	●	XC4			
XC5	●	●	●	—	XC5		
XC6	●	●	●	—	—	XC6	
XC7	●	●	●	●	●	—	XC7
XC30	●	●	●	●	●	●	●

Combination	
●	Available
—	Not available

Symbol: C1

Add connecting ports on Body (A).
(An additionally machined port will have an aluminum surface since it will be left unfinished.)

- Parallel keyway is used on the long shaft for size 40.
- This specification is not available for the rotary actuator with auto switch unit.

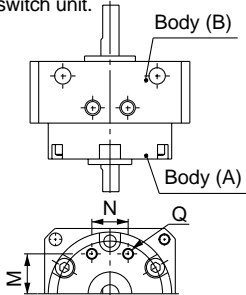

Size	Q	M	N
10	M3	8.5	9.5
15	M3	11	10
20	M5	14	13
30	M5	15.5	14
40	M5	21	20

Symbol: C2

Change 2 threaded holes on Body (B) into through holes. (An additionally machined port will have an aluminum surface since it will be left unfinished.)

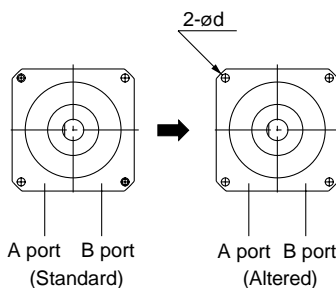

Size	d
10	3.4
15	3.4
20	4.5
30	5.5
40	5.5

Series CRBU2

Symbol: C3 Change the position of the screws for tightening the actuator body.
 • Not available for size 10.

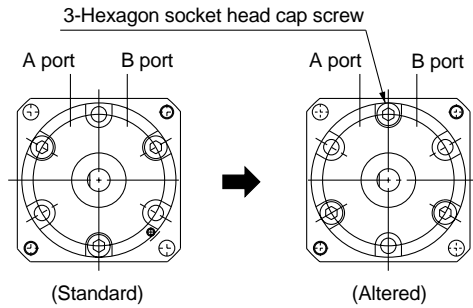

Symbol: C5 Applicable to single vane type only
 Start of rotation is 45° up from the bottom of the vertical line to the left side.
 • Rotation tolerance for CRBU2W10 is $^{+5^\circ}$.
 • A parallel keyway is used instead of chamfer for size 40.

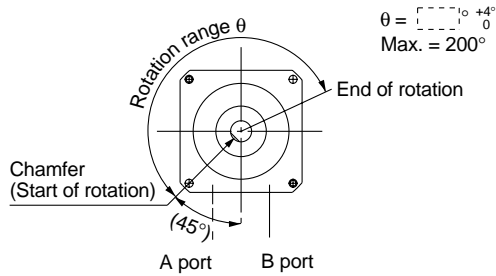

Start of rotation is the position of the chamfer (keyway) when B port is pressurized.

Symbol: C7 The shafts are reversed.
 • A parallel keyway is used instead of chamfer for size 40.

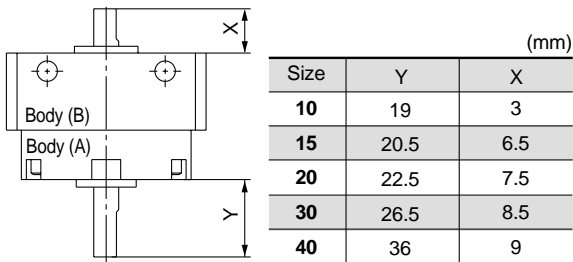

Symbol: C4 Applicable to single vane type only
 Rotation starts from the horizontal line (90° down from the top to the right side).
 • Rotation tolerance for CRBU2W10 is $^{+5^\circ}$.
 • A parallel keyway is used instead of chamfer for size 40.

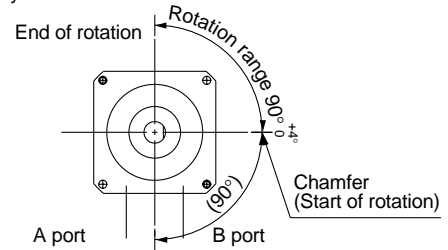

Start of rotation is the position of the chamfer (keyway) when A port is pressurized.

Symbol: C6 Applicable to single vane type only
 Rotation starts from the horizontal line (90° down from the top to the left side).
 • Rotation tolerance for CRBU2BW10 is $^{+5^\circ}$.
 • A parallel keyway is used instead of chamfer for size 40.

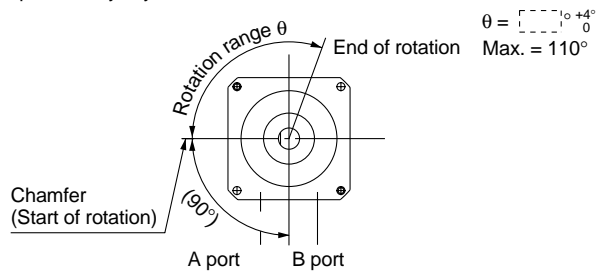

Start of rotation is the position of the chamfer (keyway) when B port is pressurized.

Symbol: C30 Change standard grease to fluorine grease.
 (Not for low-speed specification.)

Rotary Actuator: Vane Type

Series *CRB1*

Sizes: 50, 63, 80, 100

		Fluid				Air									
		Size				50		63		80		100			
Vane type		S: Single vane D: Double vane				S		D		S		D			
Port position		Side ports (Nil) Axial ports (E)				Side ports	Axial ports	Side ports	Axial ports	Side ports	Axial ports	Side ports	Axial ports		
Standard	Rotation	90°		●	●	●	●	●	●	●	●	●	●		
		180°		●	●	●	●	●	●	●	●	●	●	●	
		270°		●	●	●	●	●	●	●	●	●	●	●	
		Optional	100°		●	●	●	●	●	●	●	●	●	●	
			190°		●	●	●	●	●	●	●	●	●	●	●
			280°		●	●	●	●	●	●	●	●	●	●	●
Shaft type	Double shaft		W	●	●	●	●	●	●	●	●	●			
Cushion	Rubber bumper		●	●	●	●	●	●	●	●	●	●			
Variations	Basic type		●	●	●	●	●	●	●	●	●	●			
	With auto switch		●	●	●	●	●	●	●	●	●	●	●		
	Built-in One-touch fitting		●	●	●	●	●	●	●	●	●	●	●		
	Clean room specifications	10-	●	●	●	●	●	●	●	●	●	●			
	Copper-free	20-	●	●	●	●	●	●	●	●	●	●			
Option	Mounting type	With foot bracket		L	●	●	●	●	●	●	●	●			
Made to Order	Material	Stainless steel specifications for main parts		●	●	●	●	●	●	●	●	●			
		Shaft type	Double shaft	Double shaft (Long shaft without keyway & four chamfers)	J	●	●	●	●	●	●	●	●		
	Double shaft with four chamfers			Z	●	●	●	●	●	●	●	●			
	Double shaft key			Y	●	●	●	●	●	●	●	●			
	Double round shaft			K	●	●	●	●	●	●	●	●			
	Single shaft	Single shaft key	Single shaft key	S	●	●	●	●	●	●	●	●			
			Single round shaft	T	●	●	●	●	●	●	●	●			
			Single shaft with four chamfers	X	●	●	●	●	●	●	●	●			
			Pattern	Shaft pattern		●	●	●	●	●	●	●	●	●	
	Rotation pattern			●	●	●	●	●	●	●	●	●	●		
With solenoid valve		●	●	●	●	●	●	●	●	●	●	●			

CRB2

Free-Mounting Type
CRBU2

CRB1

Vane Type: Rotary Actuator

Series CRB1

Sizes: 50, 63, 80, 100

How to Order

Standard

E CRB1 **B** **W** **80**—**90** **S** □

With auto switch

E CDRB1 **B** **W** **80**—**90** **S** □ **R73** □ □

Thread Port

—	Rc(PT)
E	G(PF)

With auto switch

Mounting

B	Basic type
L*	Foot type

Refer to Table 1 below if only foot assembly is required separately.
* Foot accessory is shipped together with the actuator but not mounted on it.

Table 1: Foot assembly part no.

Model	Unit part no.
CRB1LW 50	P411020-5
CRB1LW 63	P411030-5
CRB1LW 80	P411040-5
CRB1LW100	P411050-5

Size

50
63
80
100

Number of auto switches

S	1 pc.*
Nil	2 pcs.

* Right-hand auto switch will be used for actuators with 1 auto switch.

Electrical entry/Lead wire length

Nil	Grommet, Lead wire: 0.5m
L	Grommet, Lead wire: 3m
C	Connector, Lead wire: 0.5m
CL	Connector, Lead wire: 3m
CN	Connector, Without lead wire

Notes) • Connectors are available only for auto switch types D-R73, D-R80, D-T79.
• Part numbers for lead wires with connectors, and their respective wire lengths in (), are:
D-LC05 (0.5m); D-LC30 (3m)

Auto switch type
* Select applicable auto switches from the table below.

Connecting port position

Nil	Side ports
E	Axial ports

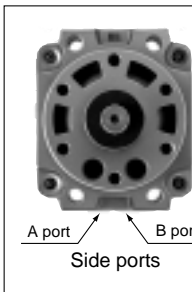
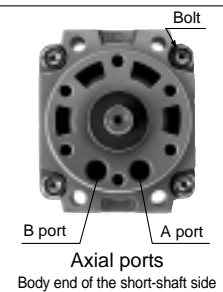
Shaft type

W	Double shaft (long shaft key & four chamfers)
----------	---

Rotation

Classification	Symbol	Single vane	Double vane
Standard	90	90°	90°
	180	180°	—
	270	270°	—
Optional	100	100°	100°
	190	190°	—
	280	280°	—

Vane type

S	Single vane
D	Double vane

Auto switch specifications: Refer to page 91 for detailed auto switch specifications.

Type	Electrical entry	Indicator light	Wiring (output)	Load voltage		Auto switch part no.	Lead wire length (m) *				Applicable loads			
				DC	AC		0.5 (Nil)	3 (L)	5 (Z)	None (N)				
Reed	Grommet	No	2-wire	24V	48V, 100V	24V, 48V, 100V	R80	●	●	—	—	IC circuit	Relay, PLC	
	Connector						R80C	●	●	●	●			
	Grommet	Yes					R73	●	●	—	—			
	Connector						R73C	●	●	●	●			
Solid state	Grommet	Yes	2-wire	24V	12V	—	T79	●	●	—	—	—	Relay, PLC	
	Connector						T79C	●	●	●	●			
	Grommet		3-wire (NPN)				S79	●	●	—	—			
							3-wire (PNP)	S7P	●	●	—			—

* Lead wire length symbol 0.5m Nil (Example) R73C 3m L (Example) R73CL 5m Z (Example) R73CZ None N (Example) R73CN

• **Excellent reliability and durability**

The use of bearings to support thrust and radial loads improves reliability and durability.

• **The body of the rotary actuator can be mounted directly.**

• **Two different port positions (side and axial) are available.**

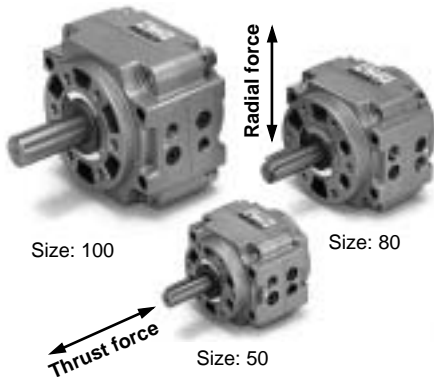

JIS symbol

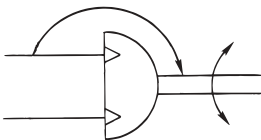

Specifications

Model (Size)	CRB1BW50	CRB1BW63	CRB1BW80	CRB1BW100	CRB1BW50	CRB1BW63	CRB1BW80	CRB1BW100	
Vane type	Single vane (S)				Double vane (D)				
Rotation	Standard	90° ⁺⁴ , 180° ⁺⁴ , 270° ⁺⁴				90° ⁺⁴			
	Optional	100° ⁺⁴ , 190° ⁺⁴ , 280° ⁺⁴				100° ⁺⁴			
Fluid	Air (non-lube)								
Proof pressure (MPa)	1.5MPa								
Ambient and fluid temperature	5° to 60°C								
Max. operating pressure (MPa)	1.0MPa								
Min. operating pressure (MPa)	0.15MPa								
Speed regulation range (sec/90°)	0.1 to 1								
Allowable kinetic energy (J)	0.082	0.12	0.398	0.6	0.112	0.16	0.54	0.811	
Shaft load	Allowable radial load (N)	245	390	490	588	245	390	490	588
	Allowable thrust load (N)	196	340	490	539	196	340	490	539
Bearing type	Ball bearing								
Port position	Side ports or axial ports								
Size	Side ports	1/8		1/4		1/8		1/4	
	Axial ports	1/8		1/4		1/8		1/4	
Mounting	Basic, Foot								

Volume

(cm³)

Classification	Rotation	Single vane (S)				Double vane (D)			
		CRB1BW50	CRB1BW63	CRB1BW80	CRB1BW100	CRB1BW50	CRB1BW63	CRB1BW80	CRB1BW100
Standard	90°	30	70	88	186	48	98	136	272
	180°	49	94	138	281	—	—	—	—
	270°	66	118	188	376	—	—	—	—
Optional	100°	32	73	93	197	52	104	146	294
	190°	51	97	143	292	—	—	—	—
	280°	68	121	193	387	—	—	—	—

Weights

(g)

Part	Rotation	Single vane (S)				Double vane (D)			
		CRB1BW50	CRB1BW63	CRB1BW80	CRB1BW100	CRB1BW50	CRB1BW63	CRB1BW80	CRB1BW100
Body	90°	810	1365	2070	3990	830	1410	2120	4150
	180°	790	1330	2010	3880	—	—	—	—
	270°	770	1290	1950	3760	—	—	—	—
	100°	808	1360	2065	3980	822	1400	2100	4100
	190°	788	1325	2005	3870	—	—	—	—
	280°	766	1285	1940	3735	—	—	—	—
Auto switch unit +2 switches		65	85	95	165	65	85	95	165
Foot bracket assembly		384	785	993	1722	384	785	993	1722

Caution

Be sure to read before handling.
Refer to pages 104 through 110 for safety instructions, actuator precautions, and auto switch precautions.

Series CRB1

Effective Output

CRB1BW50

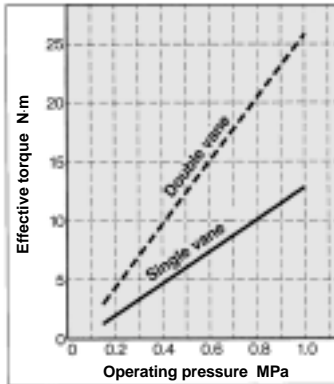

CRB1BW63

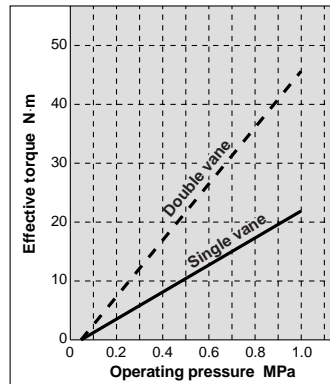

CRB1BW80

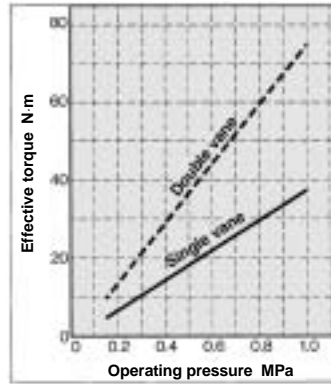

CRB1BW100

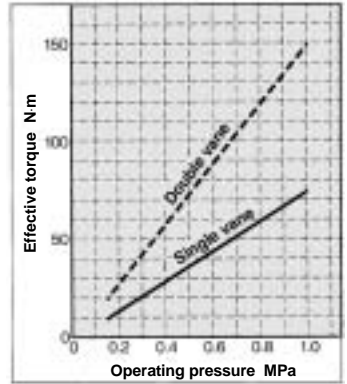

Key Position and Rotation Range: Top View from Long Shaft Side

Key positions in the illustrations below show the intermediate rotation position when A or B port is pressurized.

	Single vane type			Double vane type
Standard	90°	180°	270°	90°
Optional	100°	190°	280°	100°

Direct Mounting of Body

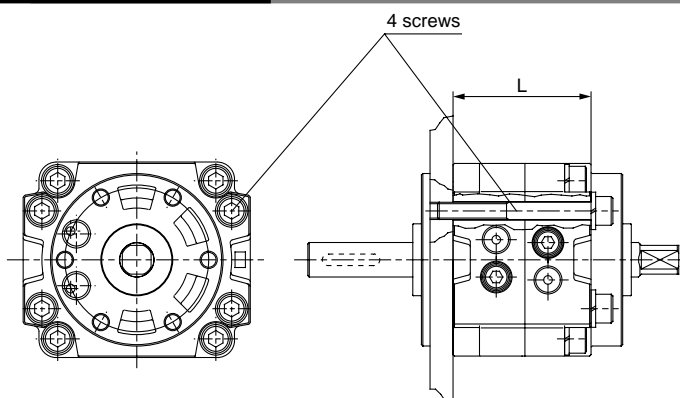

Model	L	Screw
CRB1BW 50	48	M6
CRB1BW 63	52	M8
CRB1BW 80	60	M8
CRB1BW100	80	M10

Rotary Actuator with Built-in One-Touch Fitting

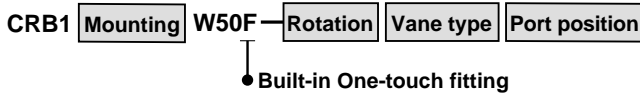

Built-in One-touch fittings facilitate the piping work and greatly reduce the installation space.

Specifications

Vane type	Single vane	Double vane
Size	50	
Operating pressure range (MPa)	0.15 to 1.0	
Speed regulation range (s/90°)	0.1 to 1	
Port position	Body ports or axial ports	
Piping	Build-in One-touch fitting	
Mounting	Basic, foot	
Variation	Basic type, with auto switch	

Applicable tube and size

Applicable tube O.D./I.D. (mm)	ø6/ø4
Applicable tube materials	Nylon, Soft nylon, Polyurethane

 Refer to page 72 for construction and page 76 for dimensions.

Rotary Actuator for Clean Room Specification

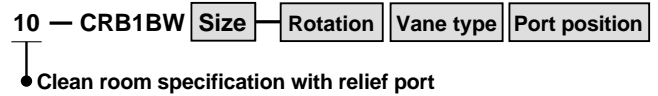

The double-seal construction of the actuator shaft section of these series to channel exhaust through the relief ports directly to the outside of a clean room environment allows operation of these cylinders in a class 100 clean room.

Specifications

Vane type	Single vane	Double vane
Size	50, 63	
Operating pressure range (MPa)	0.15 to 1.0	
Speed regulation range (s/90°)	0.1 to 1	
Port position	Body ports or axial ports	
Piping	Screw-in piping	
Relief port size	M5	
Mounting	Basic	
Variation	Basic type, with auto switch	

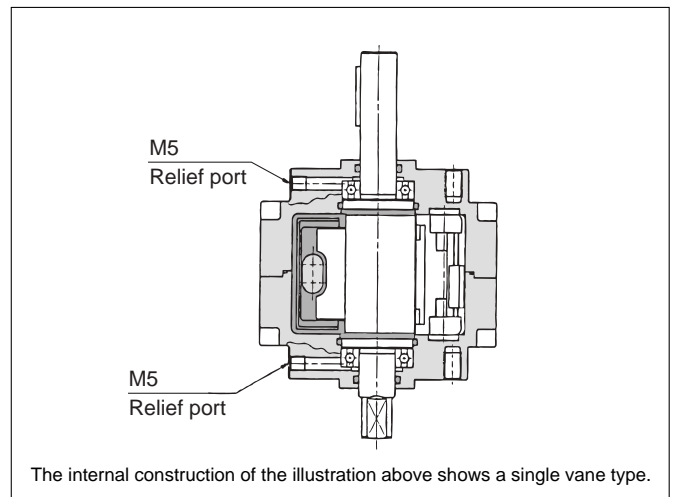

Copper-Free Rotary Actuator

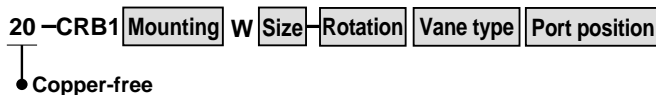

Use the standard vane type rotary actuators in all series to prevent any adverse effects to colour CRTs* due to copper ions or fluororesin.

* CRT= Cathode ray tubes

Specifications

Vane type	Single vane	Double vane
Size	50, 63, 80, 100	
Operating pressure range (MPa)	0.15 to 1.0	
Speed regulation range (s/90°)	0.1 to 1	
Port position	Body ports or axial ports	
Piping	Screw-in piping	
Mounting	Basic, foot	
Variation	Basic type, with auto switch	

Series CRB1

Rotary Actuator with Solenoid Valve

How to Order

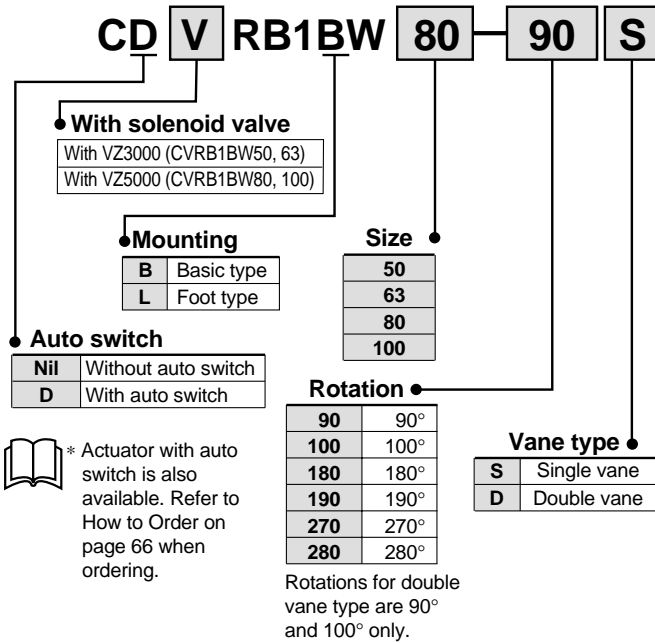

Specifications

Fluid	Air
Operating pressure (MPa)	0.15 to 0.7
Rotation	Standard: 90°, 180°, 270°; Optional: 100°, 190°, 280°
Rotation time adjustment range (s/90°)	0.3 to 1.0

Applicable solenoid valve	size50, 63: VZ3000, size80, 100: VZ5000
Operating voltage	100VAC, 200VAC, 24VDC
Electrical entry	L-plug connector, DIN terminal M-plug connector

Allowable Kinetic Energy

Size	Vane type	Allowable kinetic energy
50	Single vane	0.082J
	Double vane	0.112J
63	Single vane	0.120J
	Double vane	0.160J
80	Single vane	0.398J
	Double vane	0.54 J
100	Single vane	0.6 J
	Double vane	0.811J

* Speed regulation range: 0.3 to 1s/90°

Dimensions

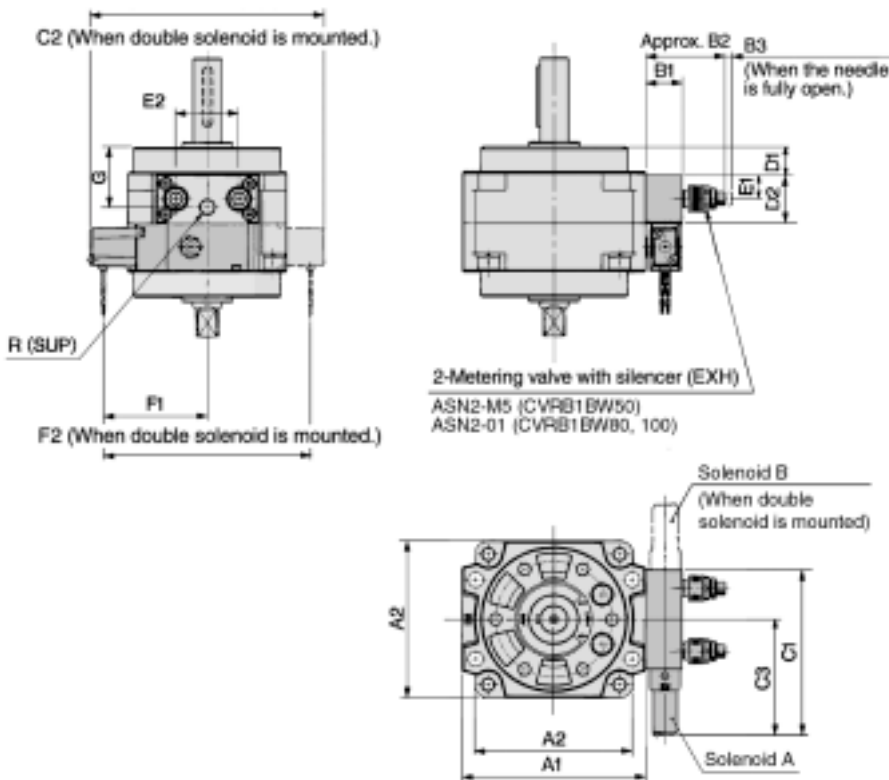

- Note 1) The solenoid valves in the illustration at left show VZ140-1G.
- Note 2) Solenoid valve dimensions are for 2-position, and dimensions in () are for 3-position.
- Note 3) Make sure to indicate the type of solenoid valve when ordering.

Model (size)	A1	A2	B1	B2	B3	C1	C2	C3	D1	D2	E1	E2	F1	F2	G	R
CVRB1BW 50	78	67	18	36	2.8	82.5	120 (136.5)	60 (61)	12	24	11.5	30	52 (53)	104 (120.5)	25	1/8
CVRB1BW 63	98	82	18	36	2.8	82.5	102 (136.5)	60 (61)	16	24	11.5	30	52 (53)	104 (120.5)	27.5	1/8
CVRB1BW 80	110	95	22	48	4	100	140 (155)	70 (71)	17	29	14	38	62 (63)	124 (139)	36	1/8
CVRB1BW100	140	125	22	48	4	100	140 (155)	70 (71)	23.5	29	14	38	62 (63)	124 (139)	42.5	1/8

Rotary Actuator: Replaceable Shaft

A shaft can be replaced with a different shaft type except for standard shaft type (W).

Without auto switch **CRB1B** **J** Size — Rotation Vane type Port position

Shaft type

J	Double shaft (Long shaft without keyway & four chamfers)
K	Double round shaft
S	Single shaft key
T	Single round shaft
X	Single shaft with four chamfers
Y	Double shaft key
Z	Double shaft with four chamfers

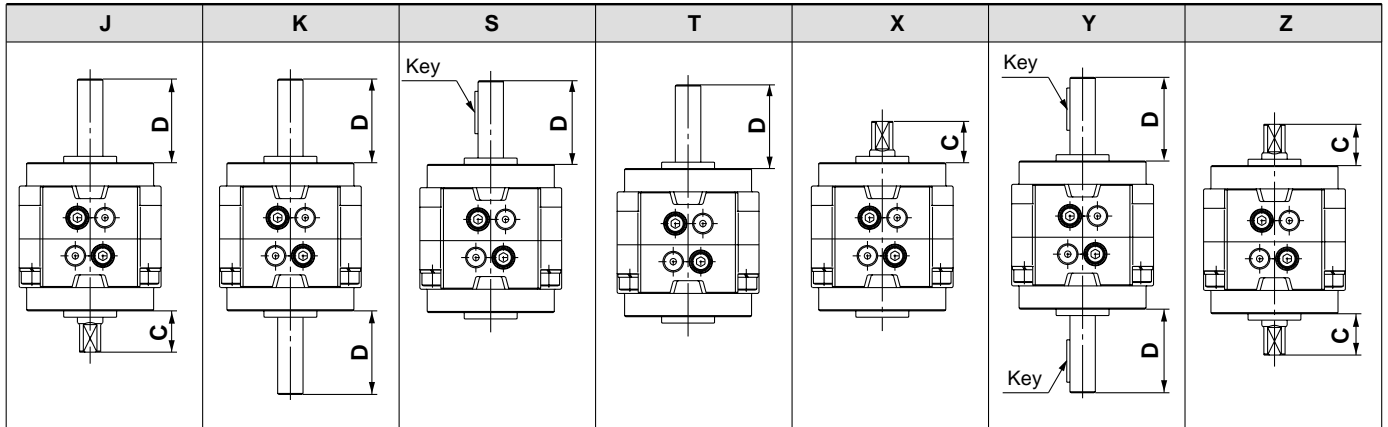

(mm)

Nominal size	C	D
50	19.5	39.5
63	21	45
80	23.5	53.5
100	30	65

Note) Dimensions and tolerance of the shaft and keyway are the same as the standard.

With auto switch **CDRB1B** **J** Size — Rotation Vane type Port position — Auto switch

With auto switch

Shaft type

J	Double shaft (Long shaft without keyway & four chamfers)
Z	Double shaft with four chamfers

(mm)

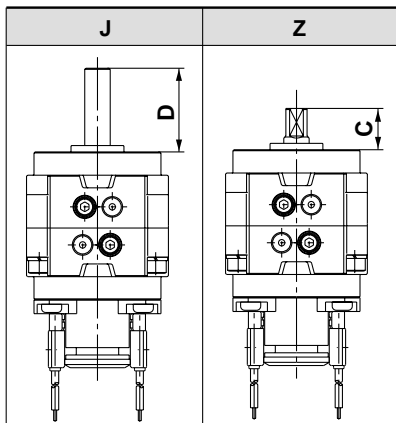

Nominal size	C	D
50	19.5	39.5
63	21	45
80	23.5	53.5
100	30	65

Note) Dimensions and tolerance of the shaft and keyway are the same as the standard.

CRB2

Free-Mounting Type
CRBU2

CRB1

Series CRB1

Construction

Standard (Keys in the illustrations below show the intermediate rotation position.)

For 270° (Top view from long-shaft side)
Single vane

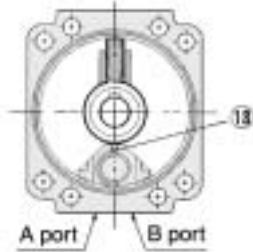

For 180° (Top view from long-shaft side)
Single vane

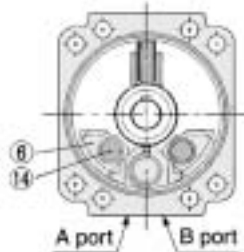

For 90° (Top view from long-shaft side)
Single vane

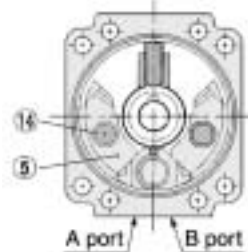

For 90° (Top view from long-shaft side)
Double vane

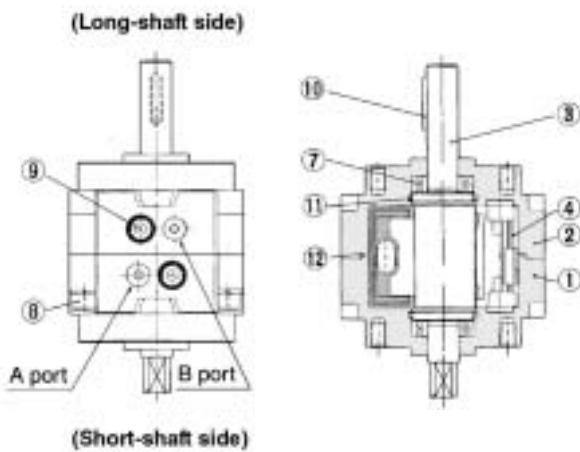
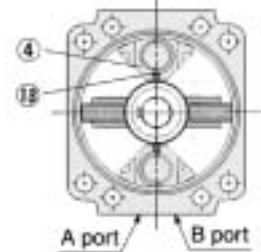

Parts list

No.	Description	Material	Note
1	Body (A)	Die-cast aluminum	CRB1BW50, 63, 80, painted
		Cast aluminum	CRB1BW100, painted
2	Body (B)	Die-cast aluminum	CRB1BW50, 63, 80, painted
		Cast aluminum	CRB1BW100, painted
3	Vane shaft	Carbon steel	
4	Stopper	Die-cast aluminum	
5	Stopper	Resin	For 90°
6	Stopper	Resin	For 180°
7	Bearing	High carbon chromium bearing steel	
8	Hexagon socket head cap screw (with washer)	Carbon steel	
9	Fuji lock bolt	Carbon steel	
10	Parallel keyway	Carbon steel	
11	O-ring	NBR	
12	O-ring	NBR	Special O-ring
13	Stopper seal	NBR	Special seal
14	Holding rubber	NBR	

With auto switch

(Keys in the illustrations below show the actuator for 180° when A port is pressurized.)

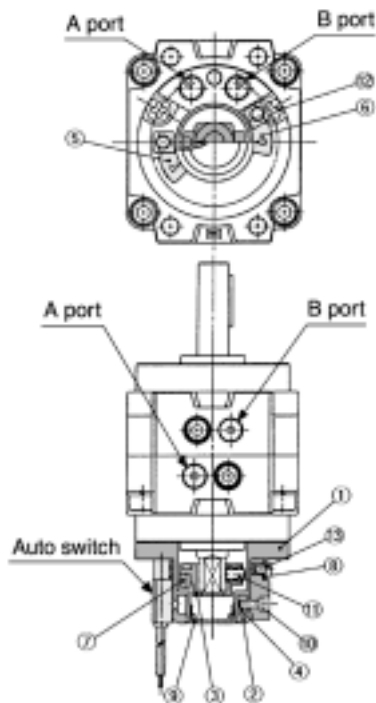

Parts list

No.	Description	Material	Note
1	Cover (A)	Resin	
2	Cover (B)	Resin	
3	Magnet lever	Resin	
4	Holding block	Aluminum alloy	
5	Switch block (A)	Resin	
6	Switch block (B)	Resin	
7	Magnet	Magnetic body	
8	Arm	Stainless steel	
9	Rubber cap	NBR	
10	Round head Phillips screw	Stainless steel	
11	Hexagon socket head set screw	Stainless steel	
12	Round head Phillips screw	Carbon steel	For CDRB1BW 50, 63, 80
	Hexagon socket head cap screw	Carbon steel	For CDRB1BW 100
13	Round head Phillips screw	Stainless steel	

Dimensions: 50, 63, 80, 100

Single vane/Double vane type

CRB1BW□-□S, D

<Port position: Side ports>

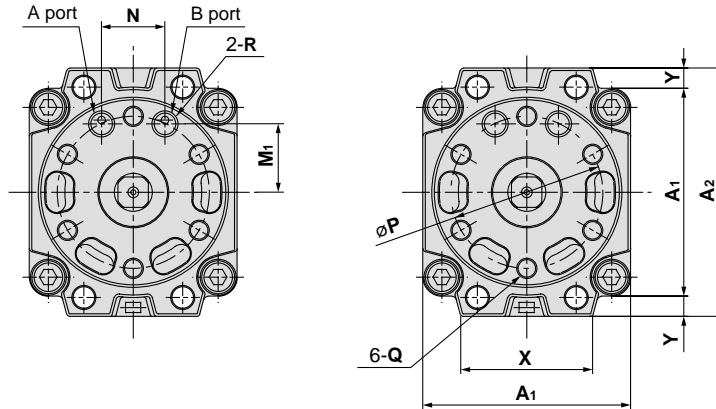

<Port position: Axial ports>

CRB1BW□-□SE, CRB1BW□-□DE

★ If B port of Body (B) is machined, the port is plugged with Rc 1/8.

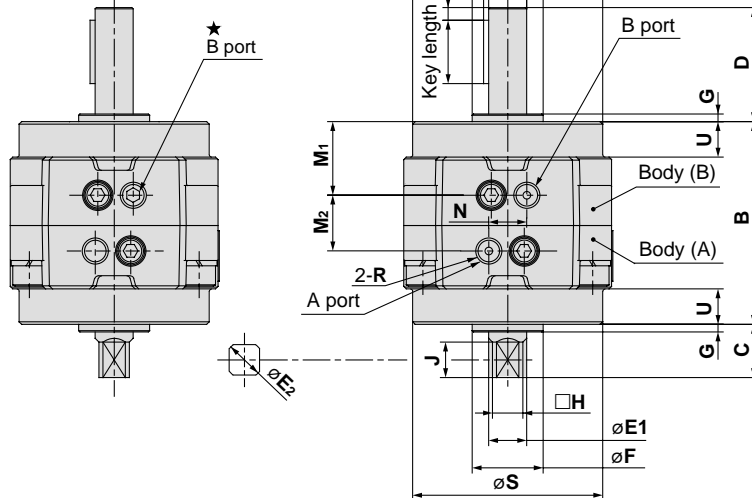

Keyway dimensions			
	b (h9)	h (h9)	L
Model			
CRB1BW 50-□□□	4 ⁰ _{-0.030}	4 ⁰ _{-0.030}	20
CRB1BW 63-□□□	5 ⁰ _{-0.030}	5 ⁰ _{-0.030}	25
CRB1BW 80-□□□	5 ⁰ _{-0.030}	5 ⁰ _{-0.030}	36
CRB1BW100-□□□	7 ⁰ _{-0.036}	7 ⁰ _{-0.036}	40

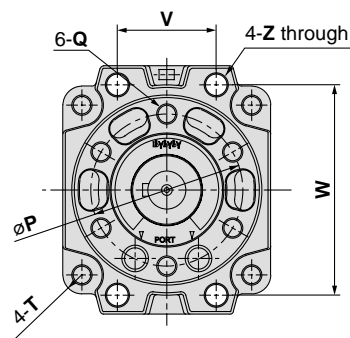

Model	(mm)																											
	A1	A2	B	C	D	E1 (g6)	E2 (h9)	F (h9)	G	H	J	K	L	M1	M2	N	P	Q	R	S	T	U	V	W	X	Y	Z	
CRB1BW 50-□□	67	78	70	19.5	39.5	12 ^{-0.006} _{-0.017}	11.9 ⁰ _{-0.043}	25 ⁰ _{-0.052}	3	10	13	5	13.5	26	18	14	50	M6 depth 9	1/8	60	R6	11	34	66	46	5.5	6.5	
CRB1BW 50-□□E														21	—	18												
CRB1BW 63-□□	82	98	80	21	45	15 ^{-0.006} _{-0.017}	14.9 ⁰ _{-0.043}	28 ⁰ _{-0.052}	3	12	14	5	17	29	22	15	60	M8 depth 10	1/8	75	R7.5	14	39	83	52	8	9	
CRB1BW 63-□□E														27	—	25												
CRB1BW 80-□□	95	110	90	23.5	53.5	17 ^{-0.006} _{-0.017}	16.9 ⁰ _{-0.043}	30 ⁰ _{-0.052}	3	13	16	5	19	30	30	20	70	M8 depth 12	1/4	88	R8	15	48	94	63	7.5	9	
CRB1BW 80-□□E														29	—	30												
CRB1BW 100-□□	125	140	103	30	65	25 ^{-0.007} _{-0.020}	24.9 ⁰ _{-0.052}	45 ⁰ _{-0.062}	4	19	22	5	28	35.5	32	24	80	M10 depth 13	1/4	108	R11	11.5	60	120	78	7.5	11	
CRB1BW 100-□□E														38	—	38												

* For single vane: Above illustrations show actuators for 180° when B port is pressurized.



Series CRB1

Dimensions: 50, 63, 80, 100 (with Auto Switch Unit)

Single vane type/Double vane type

CDRB1BW□-□S, D

<Port position: Side ports>

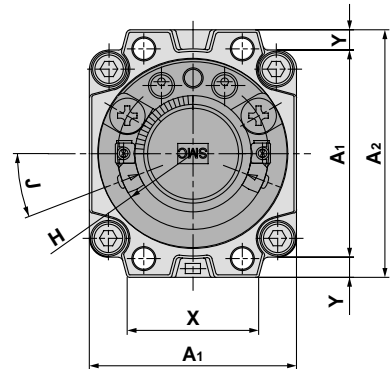
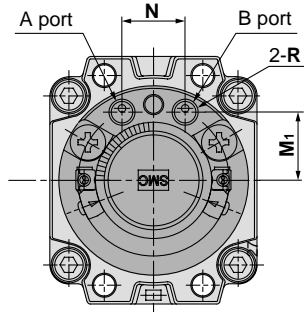

<Port position: Axial ports>

CDRB1BW□-□SE, CDRB1BW□-□DE

★ If B port of Body (B) is machined, the port is plugged with Rc 1/8.

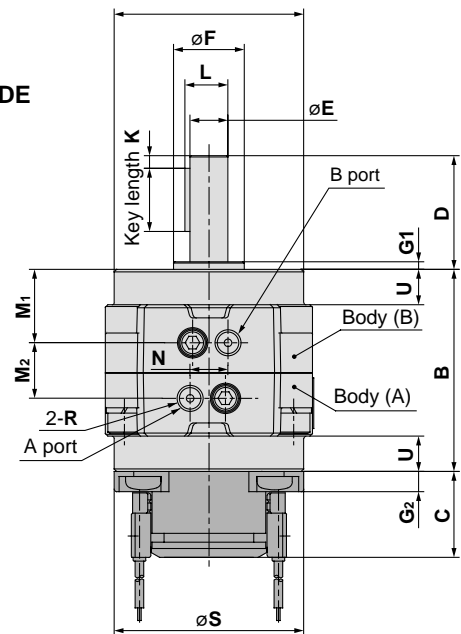
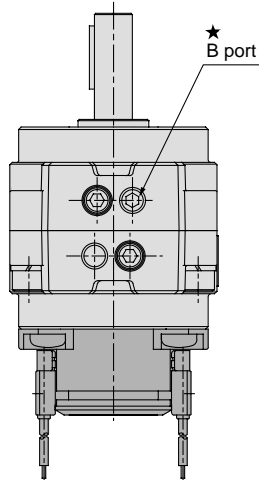

Keyway dimensions			
	b (h9)	h (h9)	L
Model			
CDRB1BW 50-□□□	4 ⁰ _{-0.030}	4 ⁰ _{-0.030}	20
CDRB1BW 63-□□□	5 ⁰ _{-0.030}	5 ⁰ _{-0.030}	25
CDRB1BW 80-□□□	5 ⁰ _{-0.030}	5 ⁰ _{-0.030}	36
CDRB1BW100-□□□	7 ⁰ _{-0.036}	7 ⁰ _{-0.036}	40

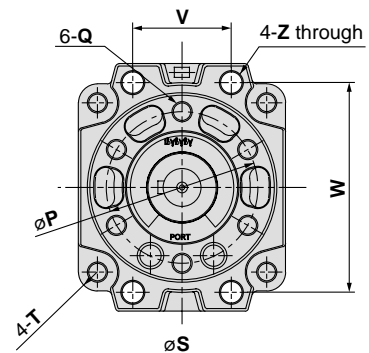

Model	A ₁	A ₂	B	C	D	E (g6)	F (h9)	G ₁	G ₂	H (R)	J	K	L	M ₁	M ₂	N	P	Q	R	S	T	U	V	W	X	Y	Z
CDRB1BW 50-□□	67	78	70	32	39.5	12 ^{-0.006} _{-0.017}	25 ⁰ _{-0.052}	3	6.5	R22.5	32.5	5	13.5	26	18	14	50	M6 depth 9	1/8	60	R6	11	34	66	46	5.5	6.5
CDRB1BW 50-□□E														21	—	18											
CDRB1BW 63-□□	82	98	80	34	45	15 ^{-0.006} _{-0.017}	28 ⁰ _{-0.052}	3	8	R30	21	5	17	29	22	15	60	M8 depth 10	1/8	75	R7.5	14	39	83	52	8	9
CDRB1BW 63-□□E														27	—	25											
CDRB1BW 80-□□	95	110	90	34	53.5	17 ^{-0.006} _{-0.017}	30 ⁰ _{-0.052}	3	8	R30	21	5	19	30	30	20	70	M8 depth 12	1/4	88	R8	15	48	94	63	7.5	9
CDRB1BW 80-□□E														29	—	30											
CDRB1BW 100-□□	125	140	103	39	65	25 ^{-0.007} _{-0.020}	45 ⁰ _{-0.062}	4	13	R30	21	5	28	35.5	32	24	80	M10 depth 13	1/4	108	R11	11.5	60	120	78	7.5	11
CDRB1BW 100-□□E														38	—	38											

* For single vane: Above illustrations show actuators for 180° when B port is pressurized.



Dimensions

Optional: Foot bracket

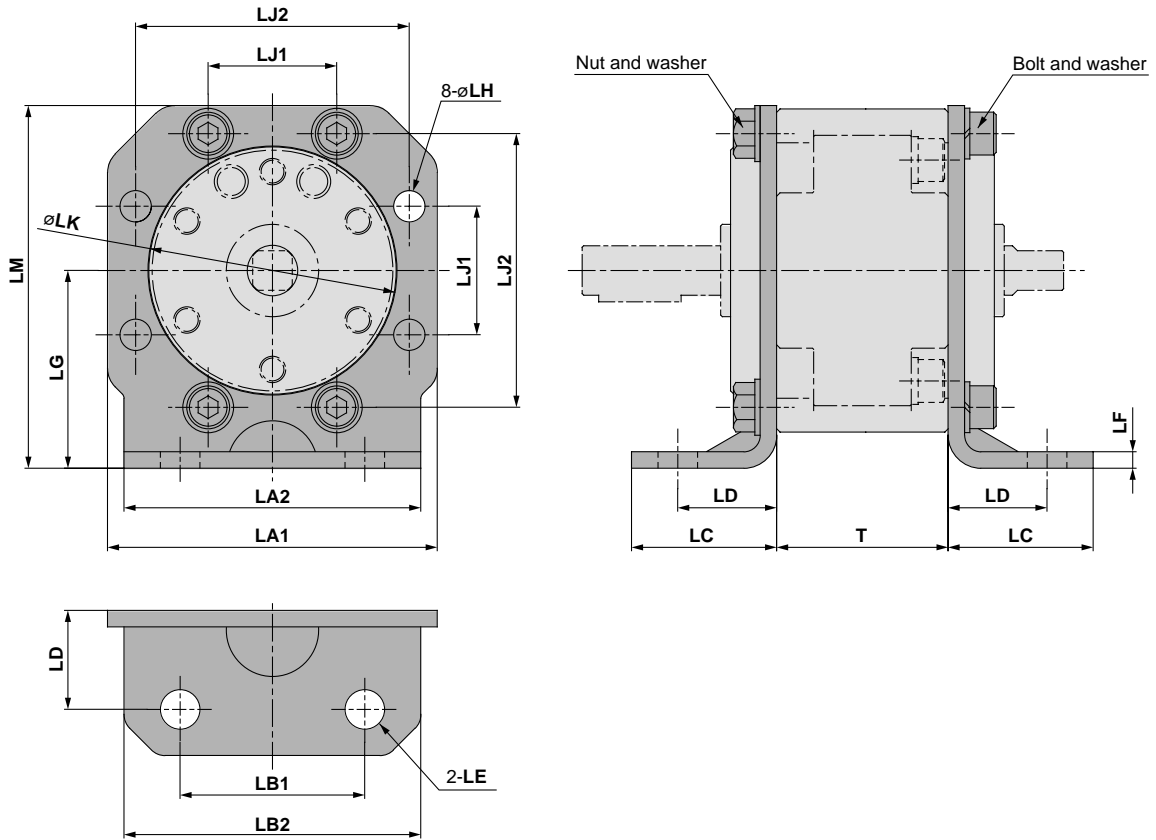

Applicable size	Foot bracket assembly no.	LA1	LA2	LB1	LB2	LC	LD	LE	LF	LG	LH	LJ1	LJ2	LK	LM	T
50	P411020-5	78	70	45	50	36	25.5	10	4.5	45	7.5	34	66	60.5	84	48
63	P411030-5	100	90	56	63	44	30	∅12	5	60	9.5	39	83	75.5	110	52
80	P411040-5	111	100	63	70	46	32	∅12	6	65	9.5	48	94	88.5	120.5	60
100	P411050-5	141	126	80	80	55	39.5	∅14	6	80	11.5	60	120	108.5	150.5	80

- Notes**
- The foot bracket (with bolt, nut, and washer) is not mounted on the actuator at the time of shipment.
 - The foot bracket can be mounted on the rotary actuator bracket 90-degree intervals.
 - Refer to the foot bracket assembly part no. in the table at right when foot bracket assembly is required separately.

Model		Foot bracket assembly no.
Basic type	With auto switch	
CRB1LW 50	CDRB1LW 50	P411020-5
CRB1LW 63	CDRB1LW 63	P411030-5
CRB1LW 80	CDRB1LW 80	P411040-5
CRB1LW100	CDRB1LW100	P411050-5

CRB2

Free-Mounting Type
CRBU2

CRB1

Series CRB1

Rotary Actuator with Built-in One-Touch Fitting: 50

Basic type

CRB1□W50F-□□

<Port position: Side ports>

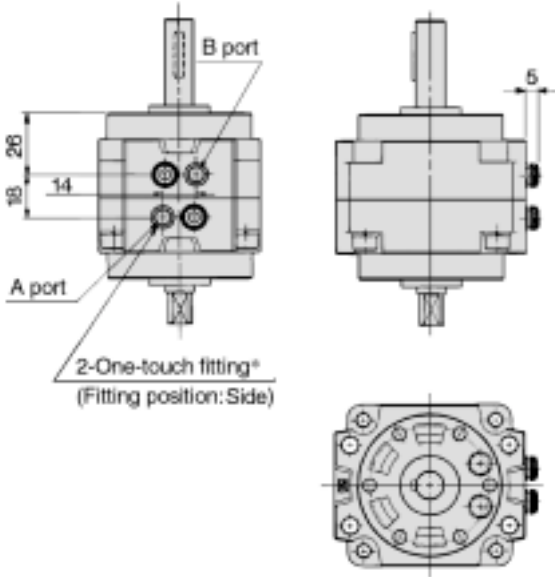

With auto switch

CDRB1□W50F-□□-□

<Port position: Side ports>

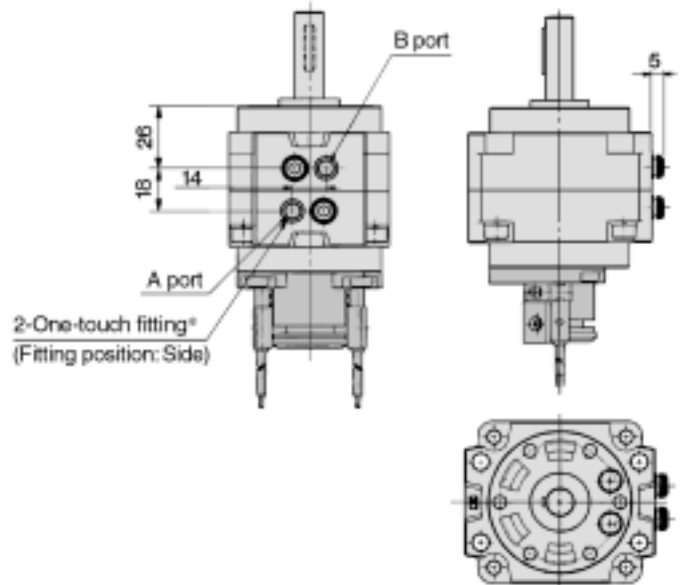

CRB1□W50F-□□E

<Port position: Axial ports>

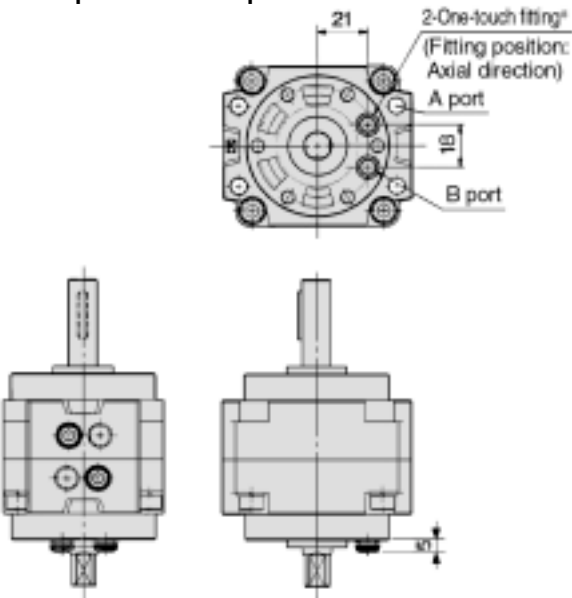

CDRB1□W50F-□□E-□

<Port position: Axial ports>

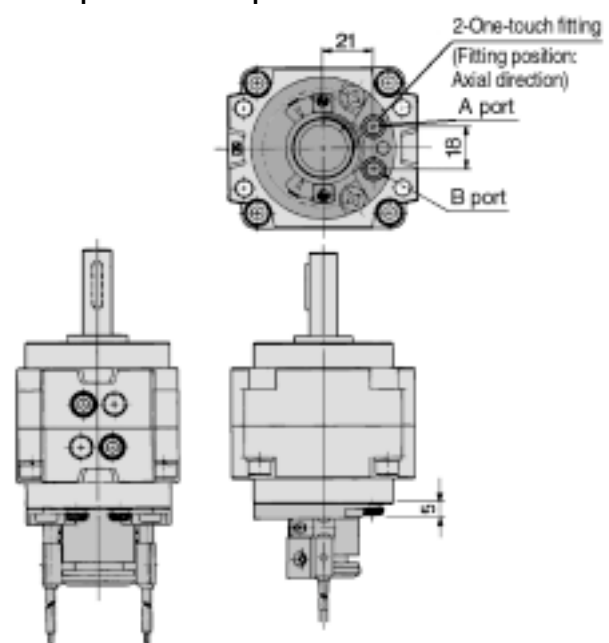

Applicable tube and size

Applicable tube O.D./I.D (mm)	ø6/ø4
Applicable tube materials	Nylon, Soft nylon, Polyurethane

 * Dimensions not indicated in the above illustrations are the same as size 50 actuator. Refer to pages 73 and 74.

* Keys in the illustrations above show the intermediate rotation position for single vane type.

Series CRB1 (Sizes: 50, 63, 80, 100) Simple Specials

-XA1 to -XA24: Shaft Pattern Sequencing 1

Simple Specials System (a system for Made to Order) will be used for Shaft Pattern Sequencing (for ordering). (Refer to Features 3.) Please contact SMC for a specification sheet when placing an order.

Shaft Pattern Sequencing 1

-XA1 to XA24

Applicable shaft type: W (Standard)

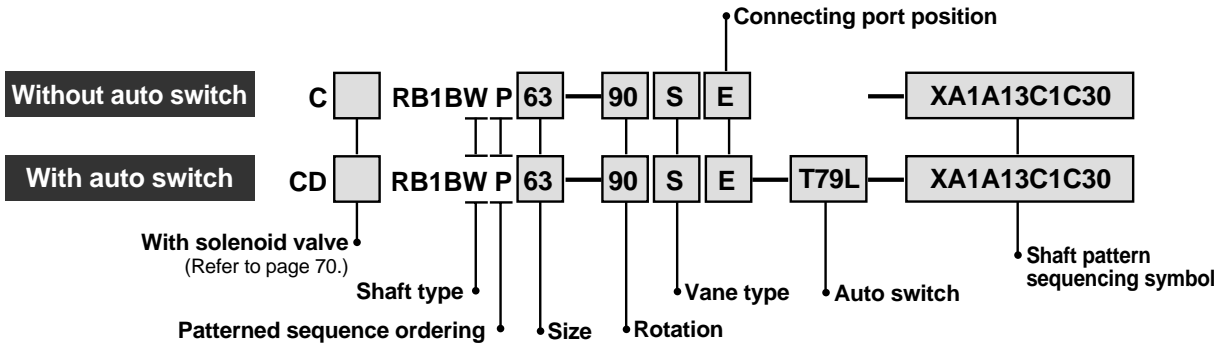

Shaft Pattern Sequencing Symbols

• Axial: Top (long-shaft side)

Symbol	Description	Applicable sizes
XA1	Shaft-end female threads	50, 63, 80, 100
XA14*	Shaft through hole + Shaft-end female threads	
XA24	Double key	

• Axial: Bottom (short-shaft side)

Symbol	Description	Applicable sizes
XA2*	Shaft-end female threads	50, 63, 80, 100
XA15*	Shaft through hole + Shaft-end female thread	

• Double shaft

Symbol	Description	Applicable sizes
XA13*	Shaft through hole	50, 63, 80, 100
XA16*	Shaft through hole + Double shaft-end female threads	



* These specifications are not available for rotary actuators with auto switch unit.

Combinations

XA□ combinations

Symbol	Combination	
	XA1	XA24
XA1	—	●
XA2	—	●
XA13	●	●
XA14	—	●
XA15	—	●
XA16	—	●
XA24	—	—

A combination of up to two XA□s are available.
Example: -XA1A13

XA□, XC□ combinations

Combination other than -XA□, such as Made to Order (-XC□), is also available. Refer to pages 82 and 83 for detailed description of Made to Order.

Symbol	Description	Applicable sizes	XA1, XA2 XA13 to 16, 24
XC1	Add connecting port	50	●
XC4	Change rotation range and direction		●
XC5	Change rotation range and direction		●
XC6	Change rotation range and direction	63	●
XC7	Reversed shaft		—
XC26	Change rotation range and direction	80	●
XC27	Change rotation range and direction		●
XC30	Fluorine grease	100	●

* A total of four XA□ and XC□ combinations is available.
Examples: -XA1A13C1C30

Combination

●	Available
—	Not available

CRB2

Free-Mounting Type
CRBU2

CRB1

Series CRB1

Axial: Top (Long-shaft side)

Symbol: A1 Machine female threads into the long shaft.

- The maximum dimension L1 is, as a rule, twice the thread size. (Example) For M3: L1 = 6mm
- Applicable shaft type: W

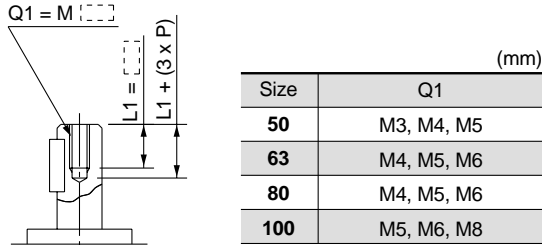

Symbol: A14 Applicable to single vane type only

A special end is machined onto the long shaft, and a through hole is drilled into it. Female threads are machined into the through hole, whose diameter is equivalent to the pilot hole diameter.

- The maximum L1 dimension is, as a rule, twice the thread size. (Example) For M5: L1 = 10mm
- Applicable shaft type: W

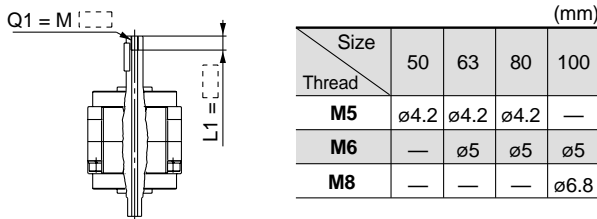

Symbol: A24 Double key

Keys and keyways are machined at 180° of standard position.

- Applicable shaft type: W
- Equal dimensions are indicated by the same marker.

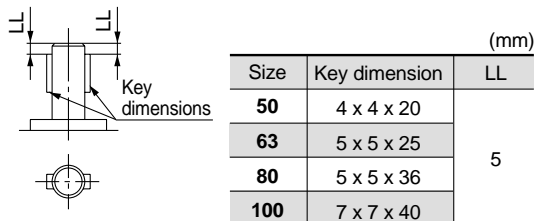

Axial: Bottom (Short-shaft side)

Symbol: A2 Machine female threads into the long shaft.

- The maximum dimension L2 is, as a rule, twice the thread size. (Example) For M4: L2 = 8mm
- Applicable shaft type: W

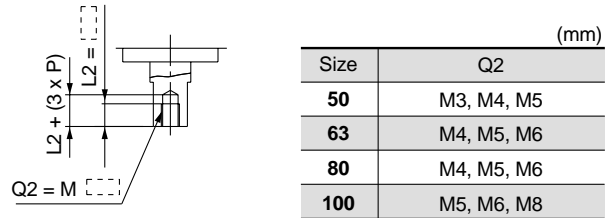

Symbol: A15 Applicable to single vane type only

A special end is machined onto the long shaft, and a through hole is drilled into it. Female threads are machined into the through hole, whose diameter is equivalent to the pilot hole diameter.

- The maximum L2 dimension is, as a rule, twice the thread size. (Example) For M5: L2 = 10mm
- Applicable shaft type: W

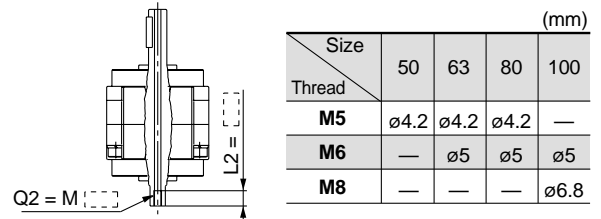

Double shaft

Symbol: A13 Applicable to single vane type only

- Shaft with through hole
- Applicable shaft type: W

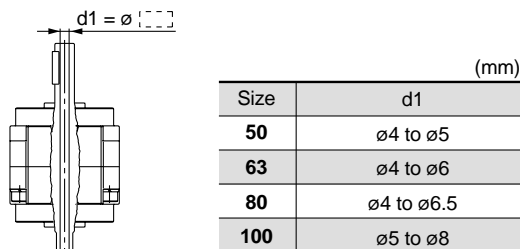

Symbol: A16 Applicable to single vane type only

A special end is machined onto both the long and short shafts, and a through hole is drilled into both. Female threads are machined into the through holes, whose diameter is equivalent to the diameter of the pilot holes.

- The maximum L1 dimension is, as a rule, twice the thread size. (Example) For M5: L1 = 10mm
- Applicable shaft type: W
- Equal dimensions are indicated by the same marker.

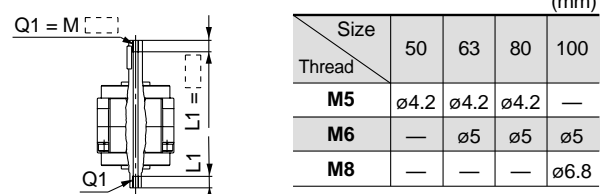

Series CRB1 (Sizes: 50, 63, 80, 100)

Simple Specials

-XA31 to -XA46: Shaft Pattern Sequencing 2

Simple Specials System (a system for Made to Order) will be used for Shaft Pattern Sequencing (for ordering). (Refer to Features 3.) Please contact SMC for a specification sheet when placing an order.

Shaft Pattern Sequencing 2

-XA31 to XA46

Applicable shaft types: J, K, S, T, X, Y, X

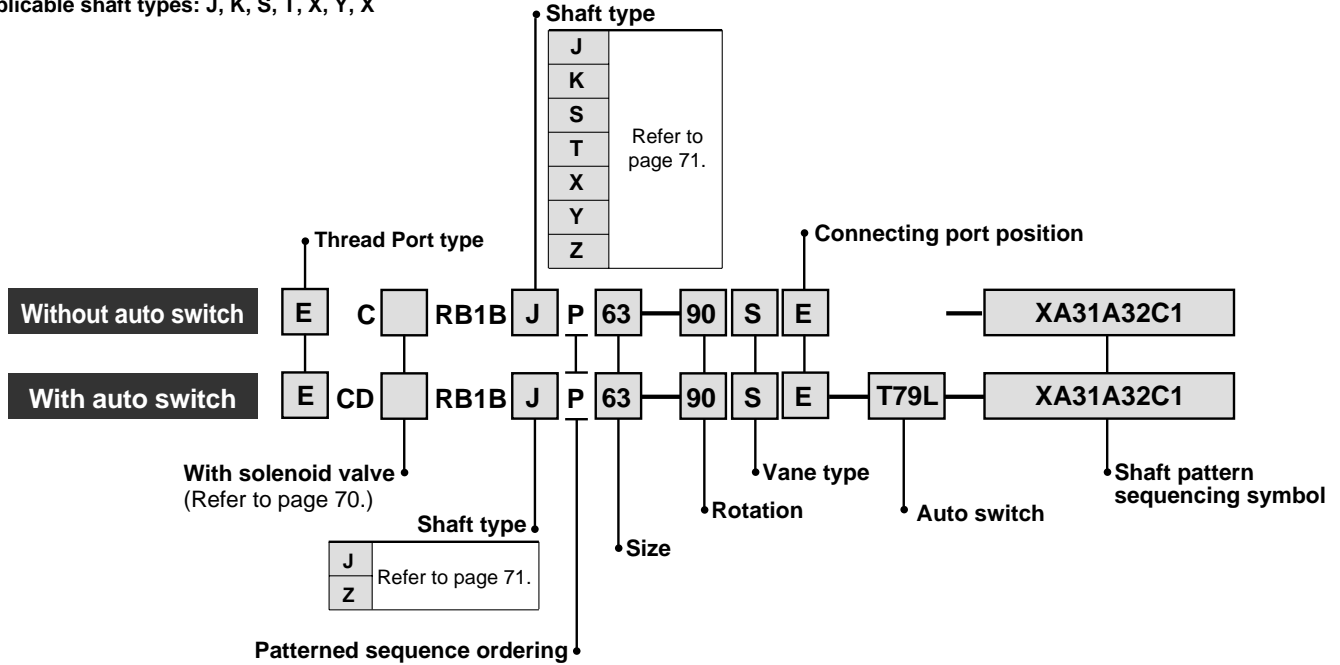

Shaft Pattern Sequencing

• Axial: Top (long-shaft side)

Symbol	Description	Shaft types	Applicable sizes
XA31	Shaft-end female threads	S, Y	50
XA33	Shaft-end female threads	J, K, T	63
XA35	Shaft-end female threads	X, Z	80
XA37	Stepped round shaft	J, K, T	100
XA45	Middle-cut chamfer	J, K, T	100

• Axial: Bottom (short-shaft side)

Symbol	Description	Shaft types	Applicable sizes
XA32*	Shaft-end female threads	S, Y	50
XA34*	Shaft-end female threads	K, T	63
XA36*	Shaft-end female threads	J, X, Z	80
XA38*	Stepped round shaft	K	100
XA46*	Middle-cut chamfer	K	100

• Double shaft

Symbol	Description	Shaft types	Applicable sizes
XA39*	Shaft through hole	S, Y	50
XA40*	Shaft through hole	K, T	63
XA41*	Shaft through hole	J, X, Z	80
XA42*	Shaft through hole + Shaft-end female threads	S, Y	100
XA43*	Shaft through hole + Shaft-end female threads	K, T	100
XA44*	Shaft through hole + Shaft-end female threads	J, X, Z	100

* These specifications are not available for rotary actuators with auto switch unit and/or angle adjuster.

Combinations

XA□ combinations

Symbol	Combination						
XA31	XA31						
XA32	●						
XA33	—	XA33					
XA34	—	●	XA34				
XA35	—	—	—	XA35			
XA36	—	J*	—	X, Z*	XA36		
XA37	—	—	K, T*	—	J*	XA37	
XA38	—	●	—	—	—	●	
XA45	—	—	K, T*	—	J*	—	XA45
XA46	—	●	—	—	—	●	●

Combinations of XA39 to XA44 with others are not available. A combination of up to two XA□s are available. Example: -XA1A24

XA□, XC□ combinations

Combination other than -XA□, such as Made to Order (-XC□), is also available. Refer to pages 82 and 83 for detailed description of Made to Order.

Symbol	Description	Shaft types	XA31 to XA46
		J, K, S, T, X, Y, Z	
XC1	Add connecting port	●	●
XC4	Change of rotation range and direction	●	●
XC5	Change of rotation range and direction	●	●
XC6	Change of rotation range and direction	●	●
XC7	Reversed shaft	J, S, T, X	—
XC26	Change of rotation range and direction	●	●
XC27	Change of rotation range and direction	●	●
XC30	Fluorine grease	●	●

* These specifications are not available for rotary actuators with auto switch unit. A total of four XA□ and XC□ combinations is available. Example: -XA1A24C1C30 -XA2C1C4C30

Series CRB1

Axial: Top (Long-shaft side)

Symbol: A31 Machine female threads into the long shaft.

- The maximum dimension L1 is, as a rule, twice the thread size.
(Example) For M3: L1 = 6mm
- Applicable shaft types: S, Y

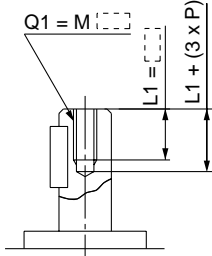

Size	Q1 (mm)	
	S	Y
50	M3, M4, M5	
63	M4, M5, M6	
80	M4, M5, M6	
100	M5, M6, M8	

Symbol: A33 Machine female threads into the long shaft.

- The maximum dimension L1 is, as a rule, twice the thread size.
(Example) For M3: L1 = 6mm
- Applicable shaft types: J, K, T

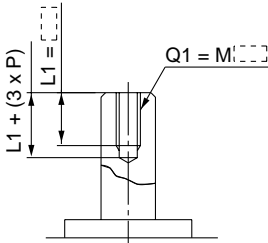

Size	Q1 (mm)		
	J	K	T
50	M3, M4, M5, M6		
63	M4, M5, M6		
80	M4, M5, M6, M8		
100	M5, M6, M8, M10		

Symbol: A35 Machine female threads into the long shaft.

- The maximum dimension L1 is, as a rule, twice the thread size.
(Example) For M3: L1 = 6mm
- Applicable shaft types: X, Z

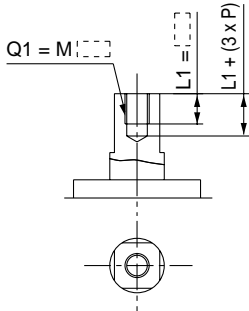

Size	Q1 (mm)	
	X	Z
50	M3, M4, M5	
63	M4, M5, M6	
80	M4, M5, M6	
100	M5, M6, M8	

Symbol: A37 The long shaft can be further shortened by machining it into a stepped round shaft. (If shortening the shaft is not required, indicate "*" for dimension X.)

- Applicable shaft types: J, K, T
- Equal dimensions are indicated by the same marker.
(If not specifying dimension C1, indicate "*" instead.)

Size	Q1 (mm)								
	X			L1 max.			D1		
	J	K	T	J	K	T	J	K	T
50	4 to 39.5			X-3			3 to 11.9		
63	4 to 45			X-3			3 to 14.9		
80	4 to 53.5			X-3			3 to 16.9		
100	5 to 65			X-4			3 to 24.9		

Axial: Bottom (Short-shaft side)

Symbol: A32 Machine female threads into the short shaft.

- The maximum dimension L2 is, as a rule, twice the thread size.
(Example) For M4: L2 = 8mm
- Applicable shaft types: S, Y

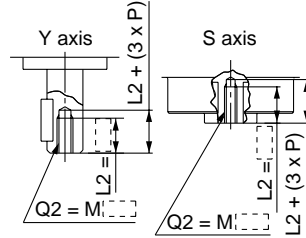

Size	Q2 (mm)	
	S	Y
50	M3, M4, M5, M6	M3, M4, M5
63	M4, M5, M6	M4, M5, M6
80	M4, M5, M6, M8	M4, M5, M6
100	M5, M6, M8, M10	M5, M6, M8

Symbol: A34 Machine female threads into the short shaft.

- The maximum dimension L2 is, as a rule, twice the thread size.
(Example) For M3: L2 = 6mm
- Applicable shaft types: K, T

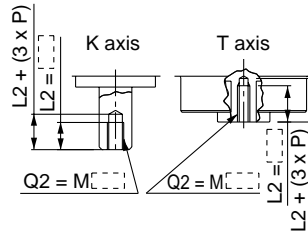

Size	Q2 (mm)	
	K	T
50	M3, M4, M5, M6	
63	M4, M5, M6	
80	M4, M5, M6, M8	
100	M5, M6, M8, M10	

Symbol: A36 Machine female threads into the short shaft.

- The maximum dimension L2 is, as a rule, twice the thread size.
(Example) For M3: L2 = 6mm
- Applicable shaft types: J, X, Z

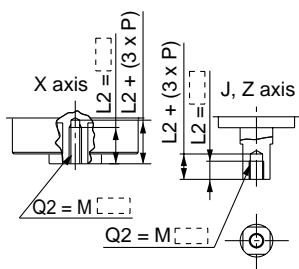

Size	Q2 (mm)		
	X	J	Z
50	M3, M4, M5, M6	M3, M4, M5	
63	M4, M5, M6	M4, M5, M6	
80	M4, M5, M6, M8	M4, M5, M6	
100	M5, M6, M8, M10	M5, M6, M8	

Symbol: A38 The short shaft can be further shortened by machining it into a stepped round shaft. (If shortening the shaft is not required, indicate "*" for dimension Y.)

- Applicable shaft type: K
- Equal dimensions are indicated by the same marker.
(If not specifying dimension C2, indicate "*" instead.)

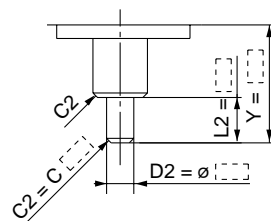

Size	Q2 (mm)		
	Y	L2 max.	D2
50	4 to 39.5	Y-3	3 to 11.9
63	4 to 45	Y-3	3 to 14.9
80	4 to 53.5	Y-3	3 to 16.9
100	5 to 65	Y-4	3 to 24.9

Axial: Top (Long-shaft side)

Symbol: **A45**

The long shaft can be further shortened by machining a middle-cut chamfer into it. (The position of the chamfer is at the standard keyway.)
(If shortening the shaft is not required, indicate "*" for dimension X.)

- Minimum machining dimension is 0.1mm.
- Applicable shaft types: J, K, T

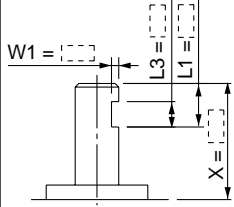

Size	X			W1			L1 max.			L3 max.		
	J	K	T	J	K	T	J	K	T	J	K	T
50	11.5 to 39.5	1 to 6	X-3	L1-2								
63	12.5 to 45	1 to 7.5	X-3	L1-2								
80	13.5 to 53.5	1 to 8.5	X-3	L1-2								
100	18.5 to 65	1 to 12.5	X-4	L1-2								

Axial: Bottom (Short-shaft side)

Symbol: **A46**

The short shaft can be further shortened by machining a middle-cut chamfer into it. (The position of the chamfer is same as the standard one.)
(If shortening the shaft is not required, indicate "*" for dimension Y.)

- Minimum machining dimension is 0.1mm.
- Applicable shaft type: K

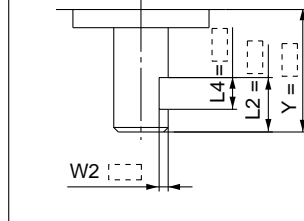

Size	Y			W2			L2 max.			L4 max.		
	J	K	T	J	K	T	J	K	T	J	K	T
50	11.5 to 39.5	1 to 6	Y-3	L2-2								
63	12.5 to 45	1 to 7.5	Y-3	L2-2								
80	13.5 to 53.5	1 to 8.5	Y-3	L2-2								
100	18.5 to 65	1 to 12.5	Y-4	L2-2								

⚠ Caution

For the shaft patterns A45 and A46, a middle-cut chamfer may interfere with the center hole if the W1/W2 dimensions and (L1-L3), (L2-L4) dimensions are less than what are shown in the tables at right.

Size	W1	W2	L1-L3	L2-L4
50	4.5 to 6	2 to 5.5		
63	6 to 7.5	2 to 3		

Size	W1	W2	L1-L3	L2-L4
80	6.5 to 8.5	2 to 6.5		
100	10.5 to 12.5	2 to 6.5		

Double shaft

Symbol: **A39**

Applicable to single vane type only
Shaft with through hole (Additional machining of S, Y shaft)

- Minimum machining diameter for d1 is 0.1mm.
- Applicable shaft types: S, Y

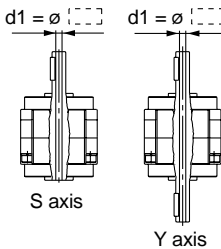

Size	d1	
	S	Y
50	ø4 to ø5	
63	ø4 to ø6	
80	ø4 to ø6.5	
100	ø5 to ø8	

Symbol: **A40**

Applicable to single vane type only
Shaft with through hole (Additional machining of K, T shaft)

- Minimum machining diameter for d1 is 0.1mm.
- d1 = d3 for sizes 20 to 40.
- Applicable shaft types: K, T

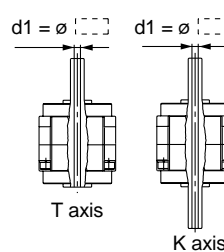

Size	d1	
	K	T
50	ø4 to ø5.5	
63	ø4 to ø6	
80	ø4 to ø7.5	
100	ø5 to ø10	

Symbol: **A41**

Applicable to single vane type only

- Shaft with through hole
- Minimum machining diameter for d1 is 0.1mm.
 - Applicable shaft types: J, X, Z

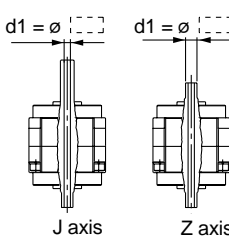

Size	d1		
	J	X	Z
50	ø4 to ø5		
63	ø4 to ø6		
80	ø4 to ø6.5		
100	ø5 to ø8		

Symbol: **A42**

Applicable to single vane type only

- A special end is machined onto both the long and short shafts, and a through hole is drilled into both shafts. Female threads are machined into the through holes, whose diameter is equivalent to the diameter of the pilot holes.
- The maximum L1 dimension is, as a rule, twice the thread size.
 - Applicable shaft types: S, Y
 - Equal dimensions are indicated by the same marker.

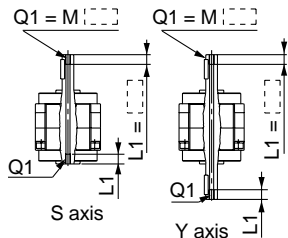

Size	50		63		80		100	
	S	Y	S	Y	S	Y	S	Y
M5	ø4.2	ø4.2	ø4.2	ø4.2	ø4.2	ø4.2		
M6	—	ø5	ø5	ø5	ø5	ø5		
M8	—	—	—	—	ø6.8	ø6.8		

Symbol: **A43**

Applicable to single vane type only

- A special end is machined onto both the long and short shafts, and a through hole is drilled into both. Female threads are machined into the through holes, whose diameter is equivalent to the diameter of the pilot holes.
- The maximum L1 dimension is, as a rule, twice the thread size.
 - Applicable shaft types: K, T
 - Equal dimensions are indicated by the same marker.

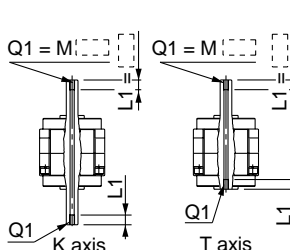

Size	50		63		80		100	
	K	T	K	T	K	T	K	T
M5	ø4.2	ø4.2	ø4.2	ø4.2	ø4.2	ø4.2		
M6	ø5	ø5	ø5	ø5	ø5	ø5		
M8	—	—	—	—	ø6.8	ø6.8		
M10	—	—	—	—	—	—	ø8.6	

Symbol: **A44**

Applicable to single vane type only

- A special end is machined onto both the long and short shafts, and a through hole is drilled into both shafts. Female threads are machined into the through holes, whose diameter is equivalent to the diameter of the pilot holes.
- The maximum L1 dimension is, as a rule, twice the thread size.
 - Applicable shaft types: J, X, Z
 - Equal dimensions are indicated by the same marker.

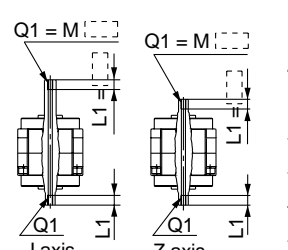

Size	50		63		80		100	
	J	X	Z	J	X	Z	J	X
M5	ø4.2	ø4.2	ø4.2	ø4.2	ø4.2	ø4.2		
M6	—	ø5	ø5	ø5	ø5	ø5		
M8	—	—	—	—	—	—	ø6.8	

Series **CRB1** (Sizes: 50, 63, 80, 100)

Made to Order

XC1, 4, 5, 6, 7, 26, 27, 30

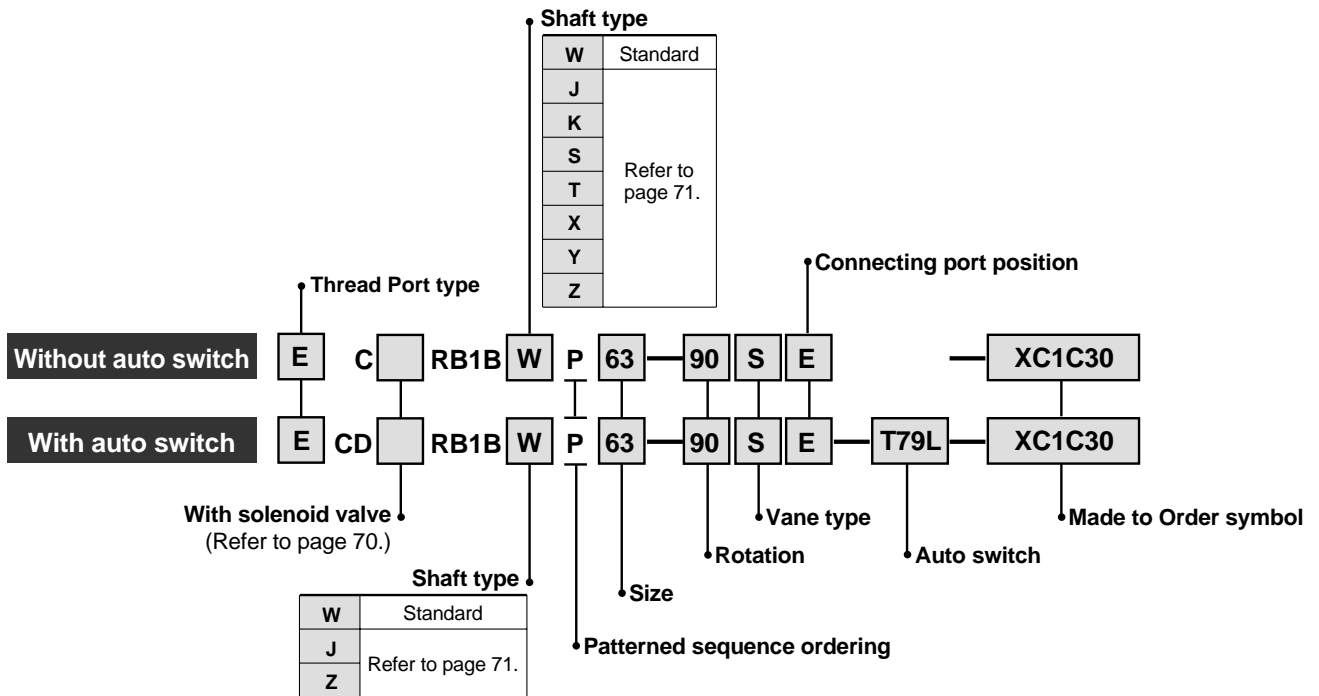

Made to Order Symbols

Symbol	Description	Applicable shaft types	Applicable sizes
		W, J, K, S, T, X, Y, Z	
XC1	Add connecting port	●	50
XC4	Change of rotation range and direction	●	
XC5	Change of rotation range and direction	●	
XC6	Change of rotation range and direction	●	63
XC7*	Reversed shaft	●	80
XC26	Change of rotation range and direction	●	
XC27	Change of rotation range and direction	●	
XC30	Fluorine grease	●	100

* This specification is not available for rotary actuators with auto switch unit and/or angle adjuster.

Combinations

Symbol	Combination	
	XC1	XC2
XC1	—	●
XC4	●	●
XC5	●	●
XC6	●	●
XC7	●	●
XC26	●	●
XC27	●	●
XC30	●	—

Symbol: C1 Add connecting ports on Body (A). (An additionally machined port will have an aluminum surface since it will be left unfinished.)

Size	Q	M	N
50	Rc 1/8	21	18
63	Rc 1/8	27	25
80	Rc 1/4	29	30
100	Rc 1/4	38	38

Symbol: C4 Change of rotation. (Applicable to single vane type only) Rotation starts from the horizontal line (90° down from the top to the right side).

Size	Rotation range θ (mm)
50	45° ^{+8°} ₀ , 90° ^{+8°} ₀ , 135° ^{+6°} ₀
63	
80	
100	

Start of rotation is the position of the key when A port is pressurized. (Top view from long-shaft side)

Symbol: C5

Change of rotation. (Applicable to single vane type only)
Rotation starts from the horizontal line (45° down from the top to the left side).

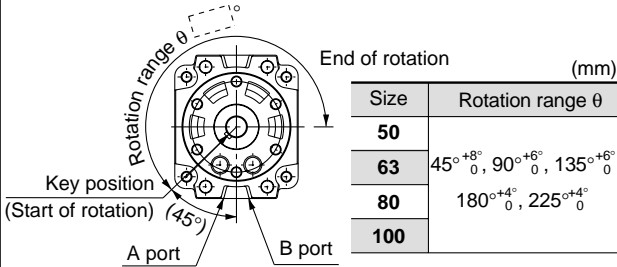

Start of rotation is the position of the key when B port is pressurized.
(Top view from long-shaft side)

Symbol: C7

The shafts are reversed.

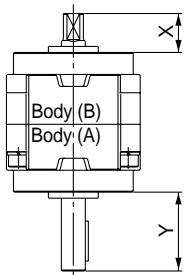

Size	Y	X
50	39.5	19.5
63	45	21
80	53.5	23.5
100	56	30

Symbol: C27

Change of rotation. (Applicable to double vane type only)
Rotation: 90° Rotation starts from the horizontal line (45° down from the top to the right side).

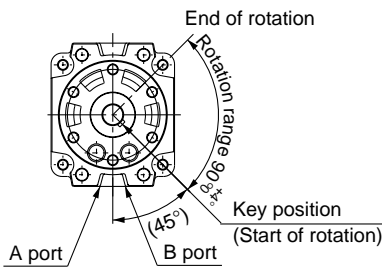

Start of rotation is the position of the key when A port is pressurized.
(Top view from long-shaft side)

Symbol: C6

Change of rotation. (Applicable to single vane type only)
Rotation starts from the horizontal line (90° down from the top to the left side).

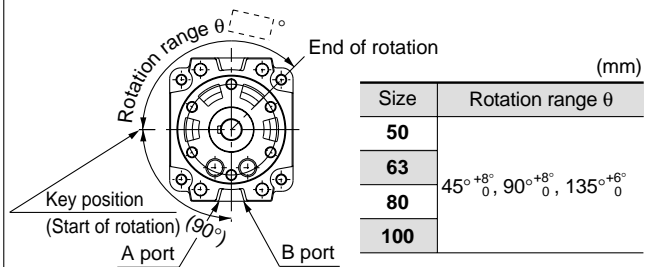

Start of rotation is the position of the key when B port is pressurized.
(Top view from long-shaft side)

Symbol: C26

Change of rotation. (Applicable to single vane type only)
Rotation starts from the horizontal line (45° down from the top to the right side).

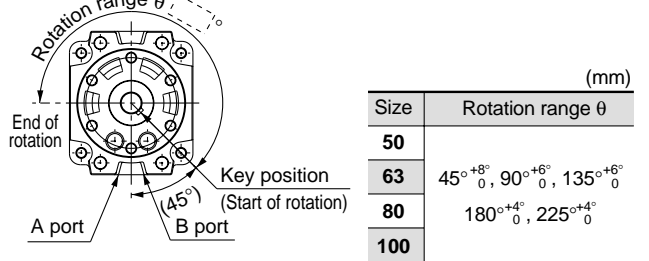

Start of rotation is the position of the key when A port is pressurized.
(Top view from long-shaft side)

Symbol: C30

Change standard grease to fluorine grease.
(Not for low-speed specification.)

CRB2

Free-Mounting Type
CRBU2

CRB1

Series CRB2/CRBU2/CRB1

Rotary Actuator

Component Unit

Auto Switch Unit and Angle Adjuster

Series CRB2/CRBU2 Auto switch unit and angle adjuster can be mounted on the rotary actuator vane type.

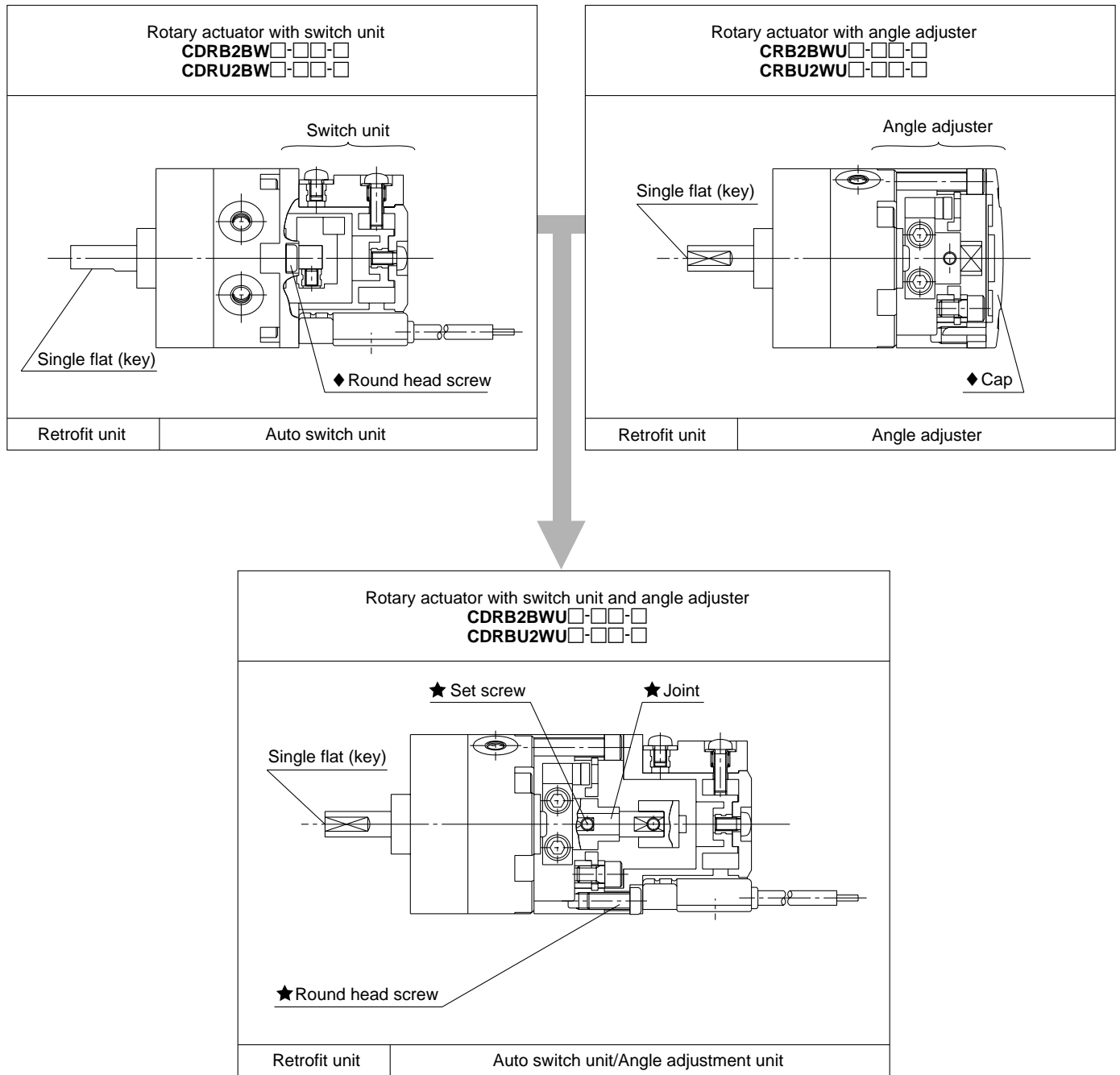

* For rotary actuator with switch unit and angle adjuster is basically a combination of a switch unit and an angle adjuster. The items marked with ★ are additionally required parts for connection (joint unit parts), and the items marked with ◆ will not be in use.

* Use a unit part number when ordering joint unit separately.

Note) Illustrations above show Series CRB2BW.

1 Auto switch unit part no.

Each unit can be retrofitted to the rotary actuator.

Series	Model	Vane type	Unit part no.
Series CRB2	CDRB2BW10	Single/Double type	P611070-1
	CDRB2BW15		P611090-1
	CDRB2BW20		P611060-1
	CDRB2BW30		P611080-1
	CDRB2BW40	Single type	P612010-1
		Double type	P611010-1
Free-mounting type Series CRBU2	CDRBU2W10	Single/Double type	P611070-1
	CDRBU2W15		P611090-1
	CDRBU2W20		P611060-1
	CDRBU2W30		P611080-1
	CDRBU2W40		P612010-1
Series CRB1	CDRB1BW50	Single/Double type	P411020-1
	CDRB1BW63		P411030-1
	CDRB1BW80		P411040-1
	CDRB1BW100		P411050-1

* Auto switch unit can be ordered separately if the rotary actuator with auto switch unit is required after the product being delivered. Auto switch itself will not be included. Please order separately.

2 Switch block unit part no.

Auto switch unit comes with one right-hand and one left-hand switch blocks that are used for addition or when the switch block is damaged.

Series	Model	Unit part no.	
Series CRB2	CDRB2BW10, 15	Right-hand	P611070-8
		Left-hand	P611070-9
	CDRB2BW20, 30	Right-hand	P611060-8
		Left-hand	
	CDRB2BW40	Right-hand	P611010-8
		Left-hand	P611010-9
Free-mounting type Series CRBU2	CDRBU2W10, 15	Right-hand	P611070-8
		Left-hand	P611070-9
	CDRBU2W20, 30	Right-hand	P611060-8
		Left-hand	
	CDRBU2W40	Right-hand	P611010-8
		Left-hand	P611010-9
Series CRB1	CDRB1BW50	Right-hand	P411020-8
		Left-hand	P411020-9
	CDRB1BW63, 80, 100	Right-hand	P411040-8
		Left-hand	P411040-9

* Solid state switch for size 10 and 15 requires no switch block, therefore the unit part no. will be P611070-13.

3 Angle adjuster part no.

Each unit can be retrofitted to the rotary actuator.

Series	Model	Vane type	Unit part no.
Series CRB2	CRB2BWU10	Single/Double type	P611070-3
	CRB2BWU15		P611090-3
	CRB2BWU20		P611060-3
	CRB2BWU30		P611080-3
	CRB2BWU40	Single type	P612010-3
		Double type	P611010-3
Free-mounting type Series CRBU2	CRBU2WU10	Single/Double type	P611070-3
	CRBU2WU15		P611090-3
	CRBU2WU20		P611060-3
	CRBU2WU30		P611080-3
	CRBU2WU40		P612010-3

4 Auto switch angle adjuster part no.

Each unit can be retrofitted to the rotary actuator.

Series	Model	Vane type	Unit part no.
Series CRB2	CDRB2BWU10	Single/Double type	P611070-4
	CDRB2BWU15		P611090-4
	CDRB2BWU20		P611060-4
	CDRB2BWU30		P611080-4
	CDRB2BWU40	Single type	P612010-4
		Double type	P611010-4
Free-mounting type Series CRBU2	CDRBU2WU10	Single/Double type	P611070-4
	CDRBU2WU15		P611090-4
	CDRBU2WU20		P611060-4
	CDRBU2WU30		P611080-4
	CDRBU2WU40		P612010-4

5 Joint unit part no.

Joint unit is a unit required to retrofit the angle adjuster to a rotary actuator with a switch unit or to retrofit the switch unit to a rotary actuator with angle adjuster.

Series	Model	Vane type	Unit part no.
Series CRB2	CDRB2BWU10	Single/Double type	P211070-10
	CDRB2BWU15		P211090-10
	CDRB2BWU20		P211060-10
	CDRB2BWU30		P211080-10
	CDRB2BWU40		P211010-10
Free-mounting type Series CRBU2	CDRBU2WU10	Single/Double type	P211070-10
	CDRBU2WU15		P211090-10
	CDRBU2WU20		P211060-10
	CDRBU2WU30		P211080-10
	CDRBU2WU40		P211010-10

Series CRB2/CRBU2 Installation of Angle Adjuster

Specifications

Single vane type

Model	Rotation adjustment range	Rubber bumper
CRB2BWU10, CRBU2WU10	0 to 230°	Yes
CRB2BWU15, CRBU2WU15	0 to 240°	
CRB2BWU20, CRBU2WU20		
CRB2BWU30, CRBU2WU30		
CRB2BWU40, CRBU2WU40	0 to 230°	

- Notes) • Use rotary actuator for 270°.
- Connecting ports are side ports only.
 - The allowable kinetic energy is the same as the specifications of the rotary actuator by itself.

Double vane type

Model	Rotation adjustment range	Rubber bumper
CRB2BWU10, CRBU2WU10	0 to 90°	Yes
CRB2BWU15, CRBU2WU15		
CRB2BWU20, CRBU2WU20		
CRB2BWU30, CRBU2WU30		
CRB2BWU40, CRBU2WU40		

- Notes) • Since the maximum angle of the rotation adjustment range will be limited by the rotation when using a rotary actuator for 90°, make sure to take this into consideration when ordering.
- Rotary actuator for 90° should be used to adjust the angle of 85° or less as a guide.
- Connecting ports are side ports only.
 - The allowable kinetic energy is the same as the specifications of the rotary actuator by itself.

Rotation Adjustment Method

Remove the resin cap in the illustrations below, slide the stopper block on the long groove and lock it into the appropriate position to adjust the rotation and rotation position. Protruding four chamfers for wrench on the output shaft that rotates allow manual operation and convenient positioning. (Refer to the rotation setting examples shown in the next page for details.)

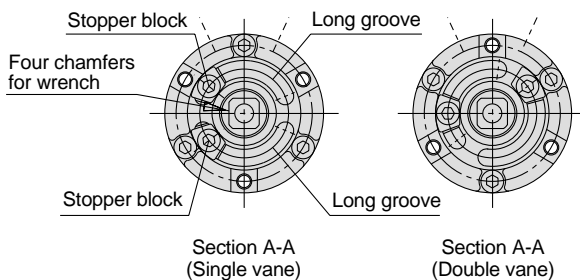

Note) For size 40, each stopper block comes with 2 holding bolts.

Recommended Tightening Torque for Holding Stopper Block

Model	Tightening torque N·m
CRB2BWU10, CRBU2WU10	1.0 to 1.2
CRB2BWU15, CRBU2WU15	
CRB2BWU20, CRBU2WU20	2.5 to 2.9
CRB2BWU30, CRBU2WU30	3.4 to 3.9
CRB2BWU40, CRBU2WU40	

Note) Stopper block is tightened temporarily at the time of shipment. Angle is not adjusted before shipment.

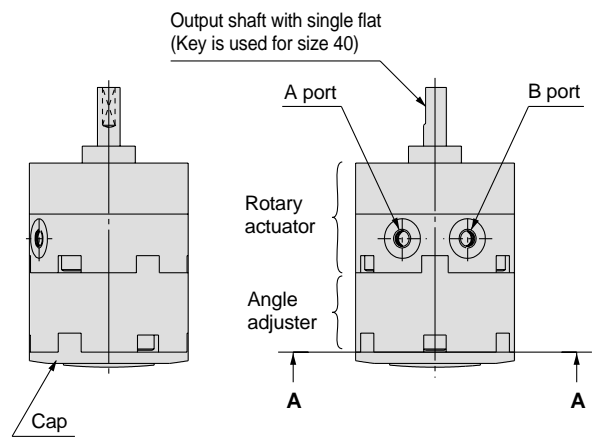

Other Operating Methods

Although one stopper block is mounted on each long groove for standard specifications as shown in the illustrations below, 2 stopper blocks can be mounted on one long groove.

Angle adjustment range when 2 stopper blocks are mounted on a single long groove:

Sizes: 10, 40 50°
 Sizes: 15, 20, 30 60°

When 2 stopper blocks are mounted on a single long groove as shown in <Figure b>, the rotation range of the output shaft with single flat (key) can be set within 50° or 60° to left of port A and B as shown in <Figure a> by moving stopper block (A) and (B). (When mounting 2 stopper blocks on the other groove, the rotation range of the output shaft with single flat (key) can be set within 50° or 60° to right of port A and B which is opposite of what is shown in <Figure a>.)

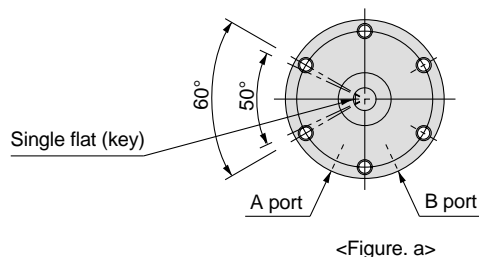

<Figure. a>

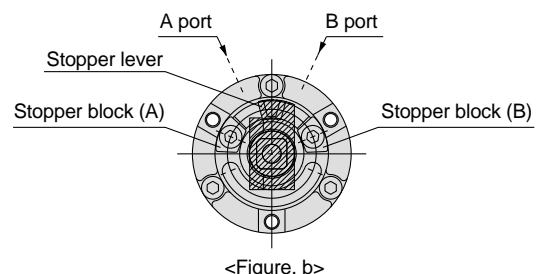

<Figure. b>

Rotation Setting Examples

Example 1 The stopper ring is mounted on the standard position.
(Rotary actuator with a rotation of 270° is used.)

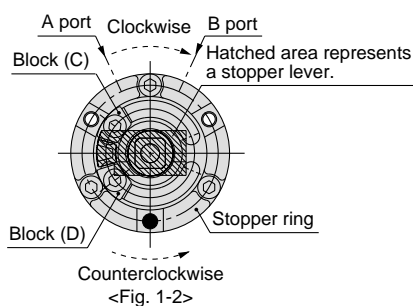
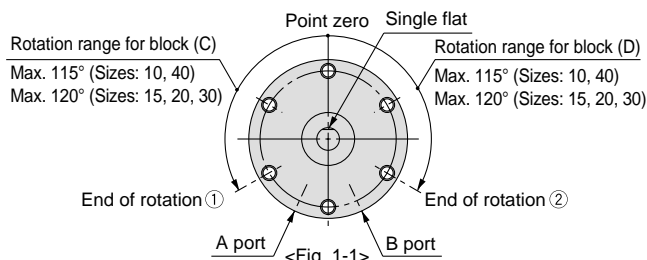

Lock block (D) in Fig. 1-2, and move block (C) clockwise to allow the rotation of the shaft with single flat in Fig. 1-1 from point zero to end of rotation ①. When block (C) is locked and block (D) is moved counterclockwise, the shaft with single flat in Fig. 1-1 rotates from point zero to end of rotation ②. The maximum rotation range of the shaft with single flat is as follows:

Sizes 10, 40: up to 230°; Sizes 15, 20, 30: up to 240°
(Fig. 1-2 shows when the rotation is 0°.)

Example 3 The stopper ring is mounted on 120° clockwise from the standard position shown in Fig. 1-2 in Example 1, just as in Fig. 4-2 of Example 4.

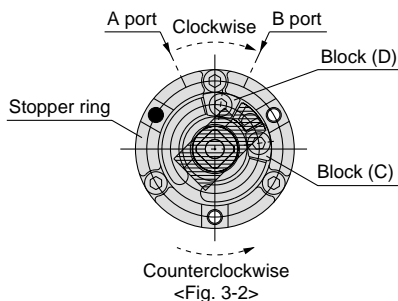
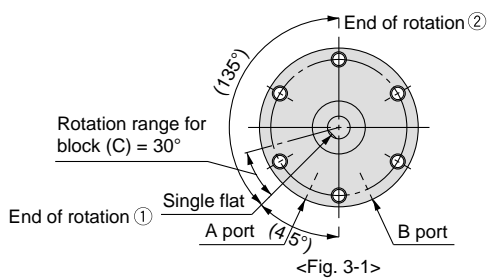

Lock block (C) in Fig. 3-2 and move block (D) counterclockwise to allow the rotation of the shaft with single flat in Fig. 3-1 from end of rotation ① to end of rotation ②. However, since the internal stopper will come into contact with the vane at end of rotation ①, make sure that the stopper lever stops at block (C) when adjusting. End of rotation side ① can be adjusted within 30° by turning block (C) counterclockwise.

Example 2 The stopper ring is mounted on 120° counterclockwise from the standard position shown in Fig. 1-2 in Example 1.

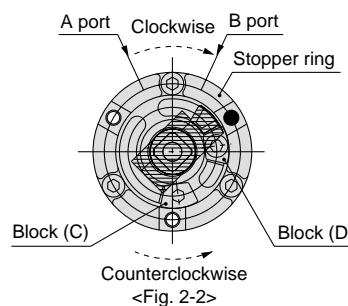
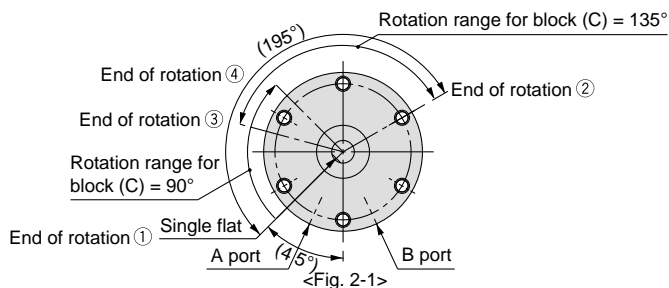

The maximum rotation range of the shaft with single flat in Fig. 2-2 is 195°, from end of rotation ① to end of rotation ②. The rotation range decreases to the range between end of rotation ② and ③ as in 2-1 when moving block (C) in Fig. 2-2 clockwise, and similarly when block (D) is moved counterclockwise, the rotation range decreases to the range between end of rotation ① and ④. However, since the internal stopper will come into contact with the vane at end of rotation ① in Fig. 2-1, make sure that the stopper lever stops at block (D) when adjusting.

Example 4 The stopper ring is mounted on 120° clockwise from the standard position shown in Fig. 1-2 in Example 1, just as in Fig. 3-2 of Example 3.

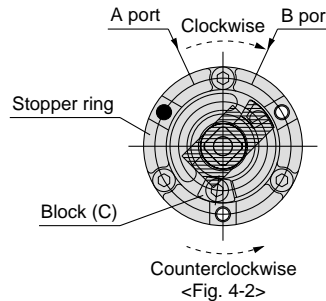
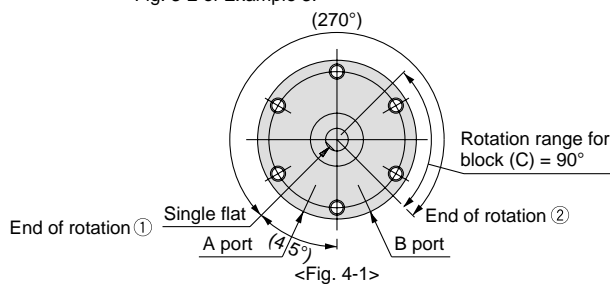

The maximum rotation range of the shaft with single flat is 270°, from end of rotation ① to end of rotation ②, when using the actuator for 270° and end of rotation ① side in Fig. 4-1 is stopped with the internal stopper and end of rotation ② side is adjusted using block (C). The rotation can be adjusted within 90° from end of rotation ②. Note that block (C) cannot be moved and set 90° counterclockwise from its position in Fig. 4-2 since the internal stopper will come into contact with the vane.

Note 1) Mounting of the stopper ring shown in Examples 2, 3, and 4 are not applicable for size 10.

Note 2) ● marks in the illustrations above indicate the position of the stopper ring assembly.

Note 3) Select the appropriate rotation of the rotary actuator by itself after careful consideration of the content of "installation of angle adjuster".

Note 4) For size 40, each block comes with 2 holding bolts.

Rotary Actuator with Auto Switch

Applicable Auto Switch

Applicable series	Switch type		Electrical entry
CDRB2BW10, 15 CDRBU2W10, 15	Reed	D-90, D-90A	Grommet, 2-wire
		D-97, D-93A	
	Solid state	D-S99, D-S99V*	Grommet, 3-wire (NPN)
		D-S9P, D-S9PV*	Grommet, 3-wire (PNP)
		D-T99, D-T99V	Grommet, 2-wire
CDRB2BW20, 30, 40 CDRBU2W20, 30, 40 CRB1BW50, 63, 80, 100	Reed	D-R73	Grommet, 2-wire
		D-R80	Connector, 2-wire
	Solid state	D-S79*	Grommet, 3-wire (NPN)
		D-S7P*	Grommet, 3-wire (PNP)
		D-T79	Grommet, 2-wire; Connector, 2-wire

Rotation Range and Actuation Range

* Operating range: θ_m

The range between the position where the auto switch turns ON as the magnet inside the auto switch unit moves and the position where the switch turns OFF as the magnet travels the same direction.

* Hysteresis range: θ_d

The range between the position where the auto switch turns ON as the magnet inside the auto switch unit moves and the position where the switch turns OFF as the magnet travels the opposite direction.

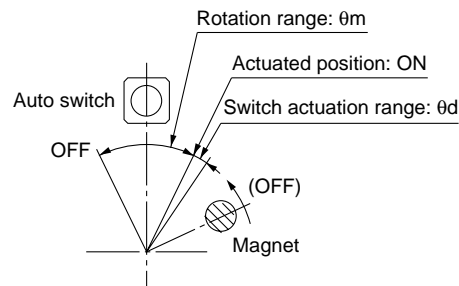

Model	Operating range: θ_m	Switch actuation range: θ_d
CDRB2BW10, 15	110°	10°
CDRBU2W10, 15		
CDRB2BW20, 30	90°	8°
CDRBU2W20, 30		
CDRB2BW40	52°	7°
CDRBU2W40		
CDRB1BW50	38°	7°
CDRB1BW63 to 100		

Moving Auto Switch Detection Position

* To set the detection position, move the switch to a desired position after loosening the set screw slightly and retighten the set screw. Do not tighten the screw past the tightening torque of approximately 0.49N·m as this could damage the switch, and the switch may not stay in place securely.

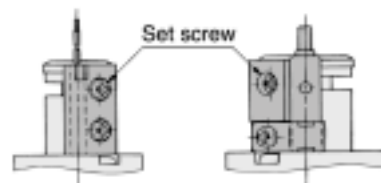

(CDRB2BW10, 15
CDRBU2W10, 15)

(CDRB2BW20 to 40
CDRBU2W20 to 30
CDRB1BW50 to 100)

Adjustment of Auto Switch

Rotation range of the output shaft with single flat (key for size 40 only) and auto switch mounting position
 Sizes: 10, 15, 20, 30, 40

<Single vane>

- * Solid-lined curves indicate the rotation range of the output shaft with single flat (key). When the single flat (key) is pointing to end of rotation ①, the switch for end of rotation ① will operate, and when the single flat (key) is pointing to end of rotation ②, the switch for end of rotation ② will operate.
- * Broken-lined curves indicate the rotation range of the built-in magnet. Rotation range of the switch can be decreased by either moving the switch for end of rotation ① clockwise or moving the switch for end of rotation ② counter-clockwise. Auto switch in the illustrations above is at the most sensitive position.
- * Each auto switch unit comes with one right-hand switch and one left-hand switch.

(CDRB2BW10 to 40)

(CDRBU2W10 to 40)

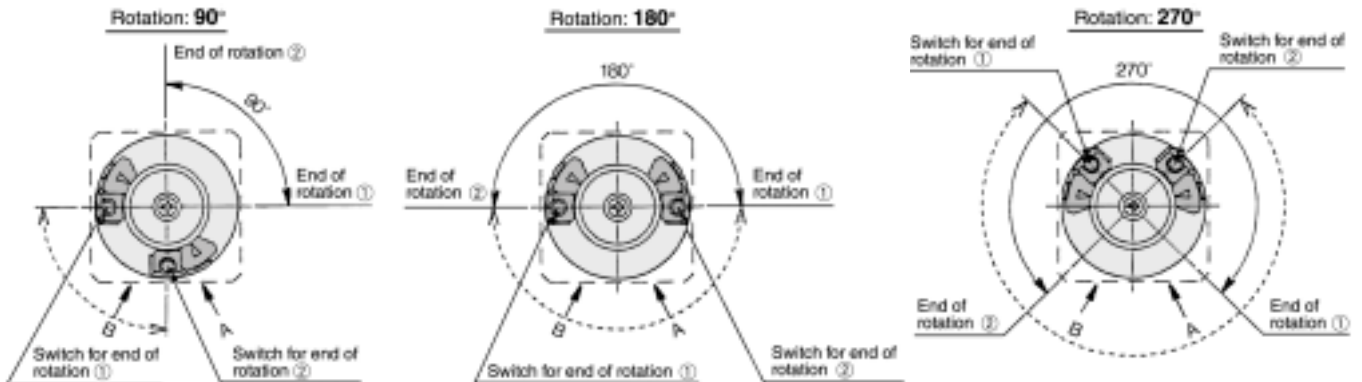
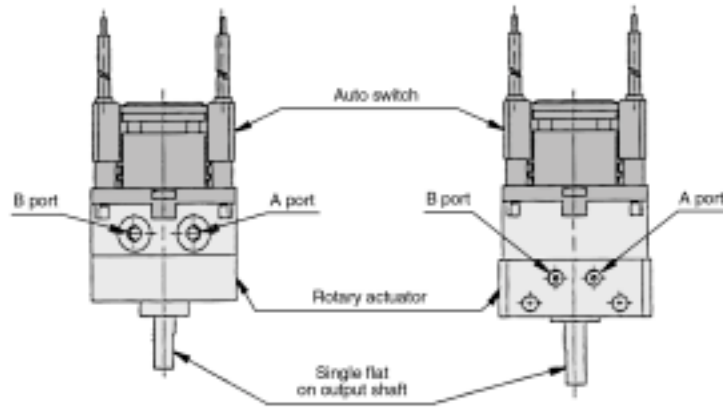

Series CDRB2/CDRBU2/CRB1

Adjustment of Auto Switch

Rotation range of the output key (keyway) and auto switch mounting position

Sizes: 50, 63, 80, 100

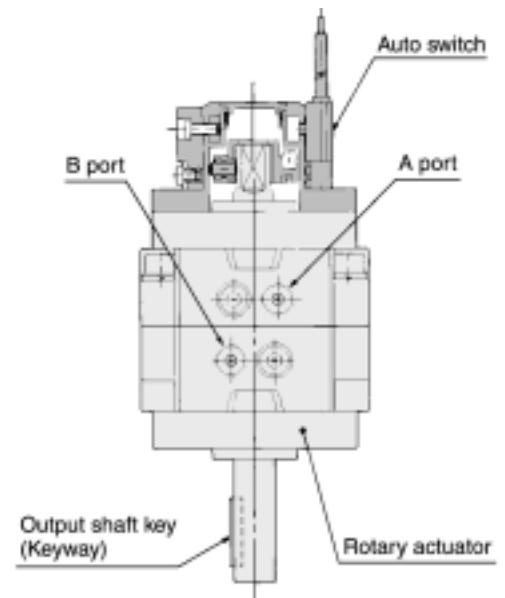
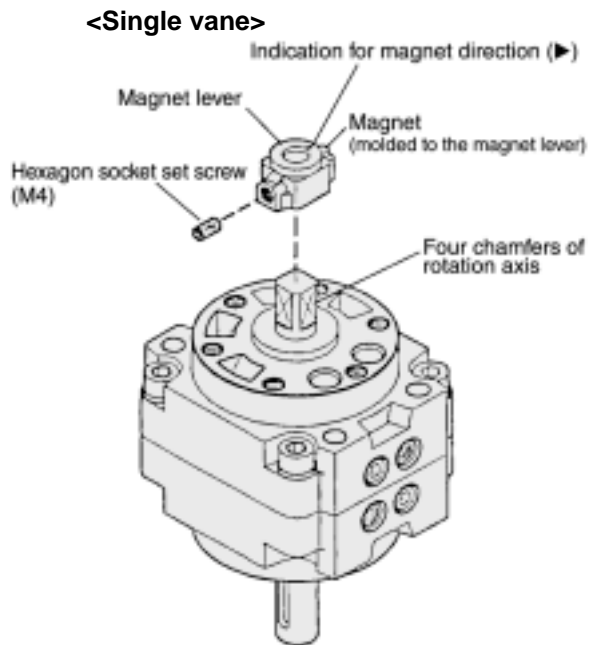

* Solid-lined curves indicate the rotation range of the output key (keyway). When the key is pointing to end of rotation ①, the switch for end of rotation ① will operate, and when the key is pointing to end of rotation ②, the switch for end of rotation ② will operate.

* Broken-lined curves indicate the rotation range of the built-in magnet. Rotation range of the switch can be decreased by either moving the switch for end of rotation ① clockwise or moving the switch for end of rotation ② counter-clockwise. Auto switch in the illustrations above is at the most sensitive position.

* Each auto switch unit comes with one right-hand and one left-hand switches.

* The magnet position can be checked with a convenient \blacktriangleright indication by removing a rubber cap when adjusting the auto switch position.

* Since four chamfers are machined into the axis of rotation, a magnet position can be readjusted at 90° intervals.

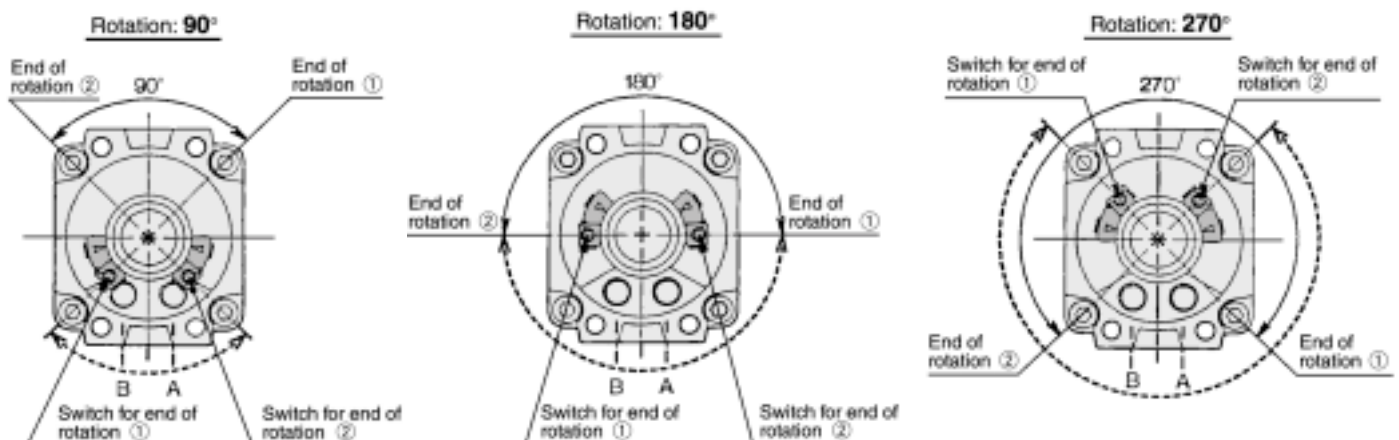
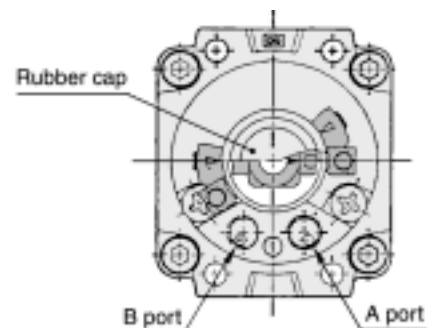

Series CRB Auto Switch Specifications

Auto Switch Common Specifications

Type	Reed switch	Solid state switch
Leakage current	None	3 wire: 100 μ A or less; 2 wire: 0.8mA or less
Operating time	1.2ms	1ms or less
Impact resistance	300m/s ²	1000m/s ²
Insulation resistance	50M Ω or more at 500VDC (between lead wire and case)	
Withstand voltage	1500VAC for 1 min.*1) (between lead wire and case)	1000VAC for 1 min. (between lead wire and case)
Ambient temperature	-10° to 60°C	
Enclosure	IEC529 standard IP67, JIS C0920 watertight construction	

*1) Electrical entry: Connector type (R73C, R80C) and D-9, D-9□A, D-A9, and D-A9□V are 1000VAC for 1 minute. (between lead wire and case)

Lead Wire Lengths

Lead wire length indication

(Example) **D-90A** **L**

Lead wire length

Nil	0.5m
L	3m
Z	5m
N*	None

* Applicable only to connector type switches D-□□C.

Note) Lead wire length: Z (5m) applicable auto switches
Reed: D-90, D-97, D-90A, D-93A, D-R73C, D-R80C
Solid state: All types are produced upon receipt of order.

Part numbers for lead wire with connector

(applicable only to connector type)

Model	Lead wire length
D-LC05	0.5m
D-LC30	3m
D-LC50	5m

Contact Protection Boxes: CD-P11, CD-P12

<Applicable switch types>

D-R73(C), D-R80(C), D-9, and D-9□A do not have built-in contact protection circuits.

A contact protection box should be used in any of the following conditions, otherwise, the life of the contacts may be reduced (They may stay on continuously):

1. The operating load is an induction load.
2. The length of wiring to the load is 5m or more.
3. The load voltage is 100 or 200VAC.

Specifications

Part no.	CD-P11		CD-P12
Load voltage	100VAC	200VAC	24VDC
Maximum load current	25mA	12.5mA	50mA

* Lead wire length — Switch connection side: 0.5m
Load connection side: 0.5m



Internal circuits

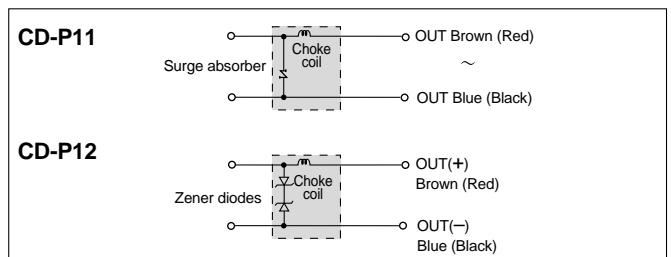

Lead wire colors inside () are those prior to conformity with IEC standards.

Dimensions

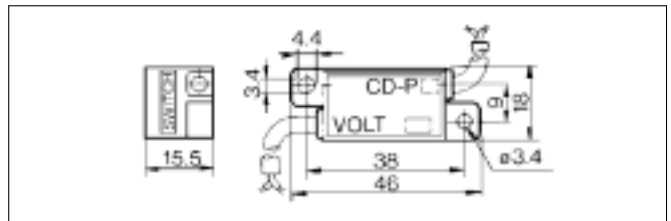

Contact Protection Box: Connection

To connect a switch unit to a contact protection box, connect the lead wire from the side of the contact protection box marked SWITCH to the lead wire coming out of the switch unit.

The switch unit should be kept as close as possible to the contact protection box with a lead wire that is no more than 1 meter in length.

Reed Switches: Direct Mount Type D-90, D97

Grommet
Lead wire: Parallel cord

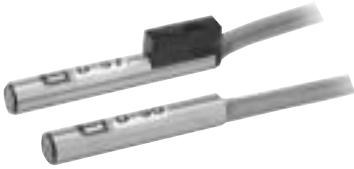

Internal circuits

Lead wire colors inside () are those prior to conformity with IEC standards.

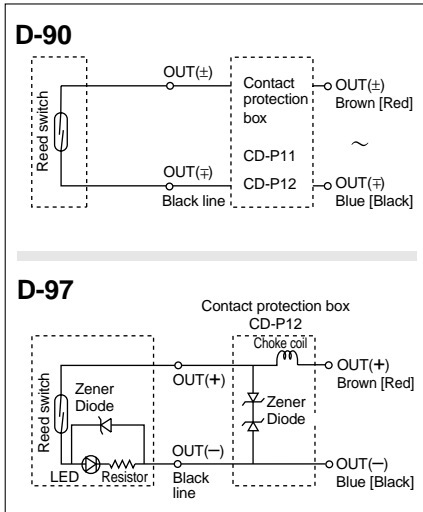

Note) Use a contact protection box in either of the following conditions, as the life of the contacts may otherwise be reduced (Refer to page 91 for details regarding contact protection boxes.):

1. The load is an induction load.
2. The lead wire length to the load is 5m or more.

Specifications

D-90 (without indicator light)

Auto switch part no.	D-90		
Application	Relay, IC circuit, PLC		
Load voltage	5V ^{AC} DC	12V ^{AC} DC	24V ^{AC} DC
Maximum load current	50mA		
Internal resistance	1Ω or less (including lead wire length of 3m)		

D-97 (with indicator light)

Auto switch part no.	D-97	
Application	Relay, PLC	
Load voltage	24VDC	
Load current range	5 to 40mA	
Internal voltage drop	2.4V or less	

• Lead wires — Parallel vinyl cord: 0.5m, 0.2mm² x 2 cores [Brown, Blue (Red, Black)]

Note) Refer to page 91 for auto switch common specifications and lead wire length.

Dimensions

D-90

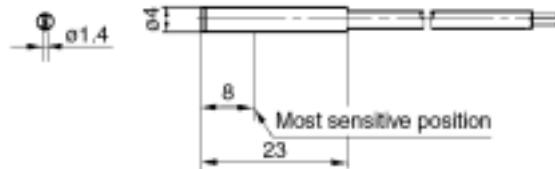

D-97

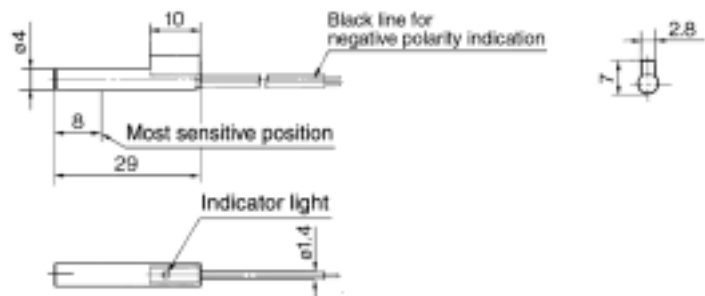

Reed Switches: Direct Mount Type

D-90A, D-93A

Grommet
Lead wire: Heavy-duty cord



Internal circuits

Lead wire colors inside () are those prior to conformity with IEC standards.

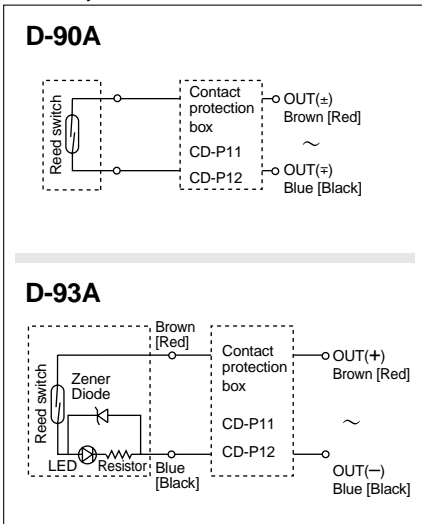

Note) Use a contact protection box in any of the following conditions, as the life of the contacts may otherwise be reduced. (Refer to page 91 for details regarding contact protection boxes.):

1. The load is an induction load.
2. The lead wire length to the load is 5m or more.
3. The load voltage is 100VAC.

Specifications

D-90A (without indicator light)

Auto switch part no.	D-90A			
Applicable load	Relay, IC circuit, PLC			
Load voltage	5V ^{AC} _{DC}	12V ^{AC} _{DC}	24V ^{AC} _{DC}	100V ^{AC} _{DC}
Maximum load current	50mA			20mA
Internal resistance	1Ω or less (including lead wire length of 3m)			

D-93A (with indicator light)

Auto switch part no.	D-93A	
Application	Relay, PLC	
Load voltage	24VDC	100VAC
Load current range	5 to 40mA	5 to 20mA
Internal voltage drop	2.4V or less	
Indicator light	Red LED lights up when ON	

• Lead wires — Oilproof heavy-duty vinyl cord: 0.5m, 0.2mm² x 2 cores [Brown, Blue (Red, Black)]
Note) Refer to page 91 for auto switch common specifications and lead wire length.

Dimensions

D-90A

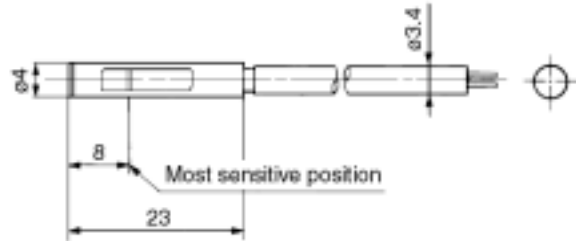

D-93A

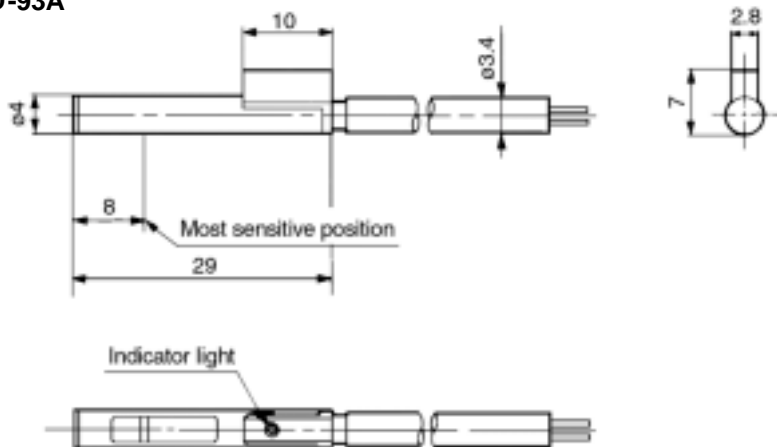

CRB2

Free-Mounting Type
CRBU2

CRB1

Reed Switches: Direct Mount Type

D-R73, D-R80

Grommet
Electrical entry direction: In-line

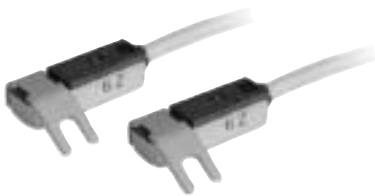

Specifications

D-R73□ (with indicator light)

Auto switch part no.	D-R731, D-R732	
Applicable load	Relay, PLC	
Load voltage	100VAC	24VDC
Maximum load current and load current range	5 to 20mA	5 to 40mA
Contact protection circuit	Not available	
Internal voltage drop	2.4V or less	
Indicator light	Red LED lights up when ON	

D-R80□ (without indicator light)

Auto switch part no.	D-R801, D-R802		
Applicable loads	Relay, IC circuit, PLC		
Load voltage	24V ^{AC} _{DC} or less	48V ^{AC} _{DC}	100V ^{AC} _{DC}
Maximum load current and load current range	50mA	40mA	20mA
Contact protection circuit	Not available		
Internal voltage drops	0		
Indicator light	None		

• Lead wires — Oilproof heavy-duty vinyl cord: 0.5m, 0.2mm² x 2 cores [Brown, Blue (Red, Black)]
Note) Refer to page 91 for auto switch common specifications and lead wire length.

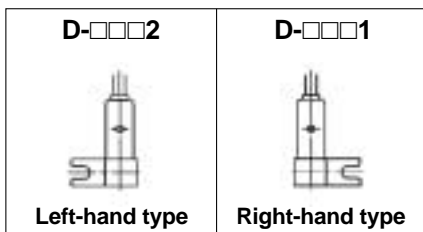

Internal circuits

Lead wire colors inside () are those prior to conformity with IEC standards.

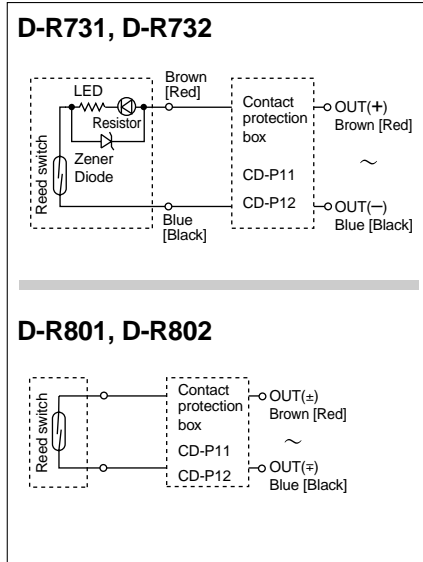

Dimensions

D-R731: Right-hand type

D-R732: Left-hand type

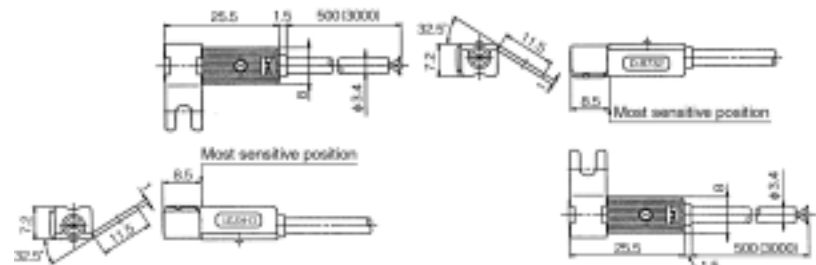

D-R801: Right-hand type

D-R802: Left-hand type

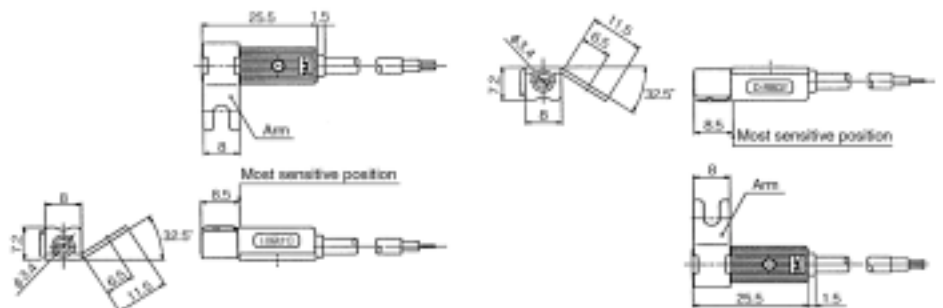

Reed Switches: Direct Mount Type

D-R73□C, D-R80□C

Connector
Electrical entry direction: In-line



Specifications

D-R73□C (with indicator light)

Auto switch part no.	D-R731C, D-R732C
Applicable load	Relay, PLC
Load voltage	24VDC
Load current range	5 to 40mA
Contact protection circuit	Not available
Internal voltage drop	2.4V or less
Indicator light	Red LED lights up when ON

D-R80□C (without indicator light)

Auto switch part no.	D-R801C, D-R802C
Applicable load	Relay, PLC
Load voltage	24V ^{AC} or less
Load current range	50mA
Contact protection circuits	Not available
Internal voltage drops	0
Indicator light	None

• Lead wires — Oilproof heavy-duty vinyl cord: 0.5m, $\phi 3.4$, 0.2mm² x 2 cores [Brown, Blue (Red, Black)]
Note) Refer to page 91 for auto switch common specifications and lead wire length.

D-□□□□C



Left-hand type

D-□□□□C



Right-hand type

Internal circuits

Lead wire colors inside () are those prior to conformity with IEC standards.

D-R731C, D-R732C

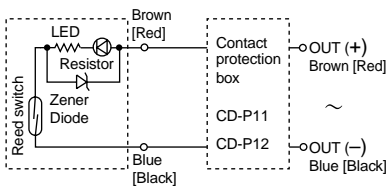

D-R801C, D-R802C

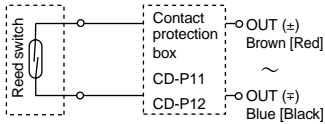

Dimensions

D-R731C: Right-hand type

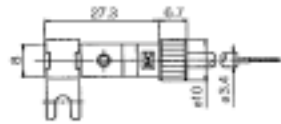

D-R732C: Left-hand type

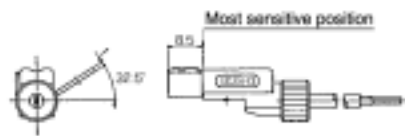

D-R801C: Right-hand type

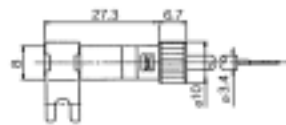

D-R802C: Left-hand type



Solid State Switches: Direct Mount Type D-S99(V), D-S9P(V), D-T99(V)

Grommet

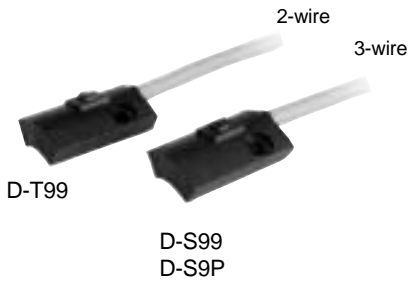

D-□991

D-□992

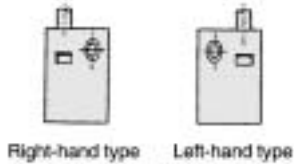

D-□99V1

D-□99V2

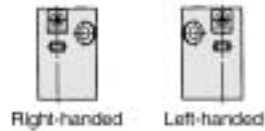

Auto switch internal circuits

Lead wire colors inside () are those prior to conformity with IEC standards.

D-S99(V)1, D-S99(V)2

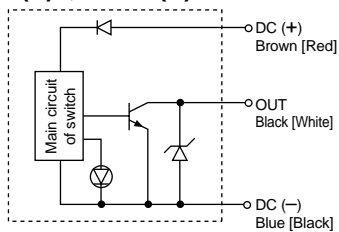

D-S9P(V)1, D-S9P(V)2

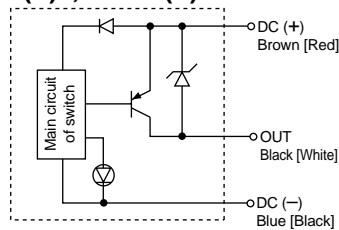

D-T99(V)1, D-T99(V)2

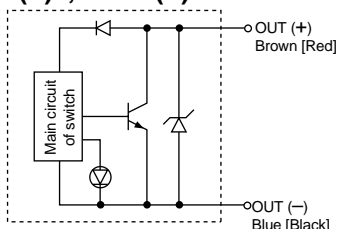

Specifications

D-S99(V), D-S9P(V), D-T99(V) (with indicator light)

Auto switch part no.	D-S991 D-S992	D-S99V1 D-S99V2	D-S9P1 D-S9P2	D-S9PV1 D-S9PV2	D-T991 D-T992	D-T99V1 D-T99V2
Electrical entry direction	In-line	Perpendicular	In-line	Perpendicular	In-line	Perpendicular
Wiring type	3-wire				2-wire	
Output type	NPN		PNP		—	
Applicable load	IC circuit, Relay, PLC				24VDC Relay, PLC	
Power supply voltage	5, 12, 24VDC (4.5 to 28VDC)				—	
Current consumption	10mA or less				—	
Load voltage	28VDC or less		—		24VDC (10 to 28VDC)	
Load current	40mA or less		80mA or less		5 to 40mA	
Internal voltage drop	1.5V or less (0.8V or less at 10mA load current)		0.8V or less		4V or less	
Leakage current	100μA or less at 24VDC				0.8mA or less at 24VDC	
Indicator light	Red LED lights up when ON					

• Lead wires — Oilproof heavy-duty vinyl cord, 0.5m, ø3.4, 0.2mm² x 3 cores [Brown, Black, Blue (Red, White, Black)]
0.2mm² x 2 cores [Brown, Blue (Red, Black)]

(Note) Refer to page 91 for auto switch common specifications and lead wire length.

Dimensions

D-S991: Right-hand type

D-S9P1:

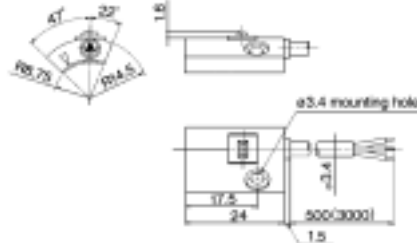

D-S992: Left-hand type

D-S9P2:

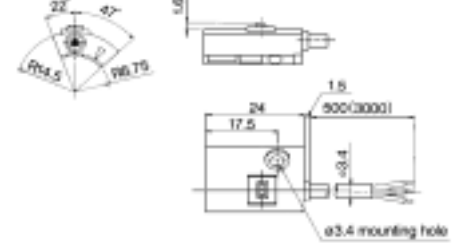

D-T991: Right-hand type

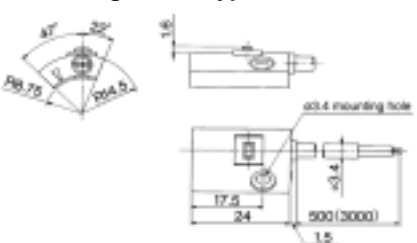

D-T992: Left-hand type

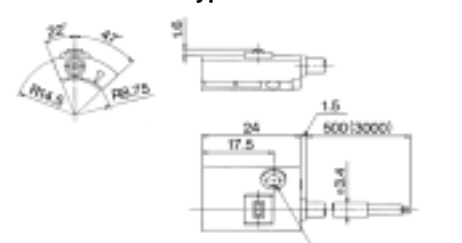

D-S99V1: Right-hand type

D-S9PV1:

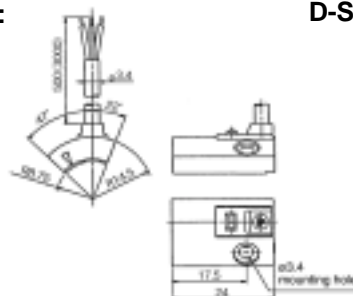

D-S99V2: Left-hand type

D-S9PV2:

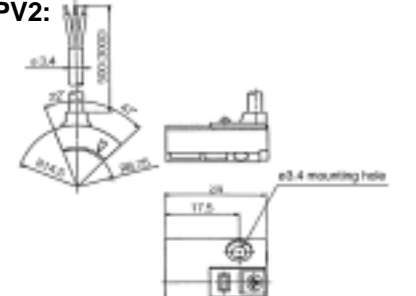

D-T99V1: Right-hand type

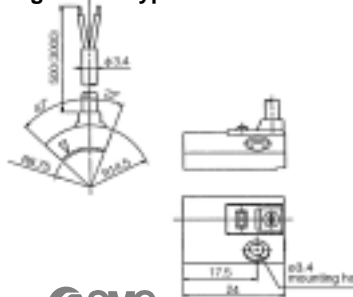

D-T99V2: Left-hand type

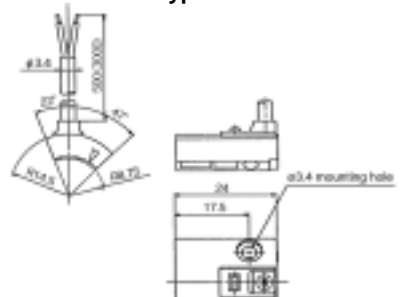

Solid State Switches: Direct Mount Type

D-S79, D-S7P, D-T79(C)

Grommet, Connector
Electrical entry direction: In-line

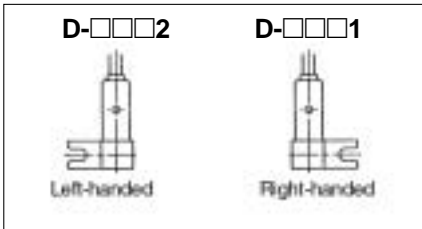
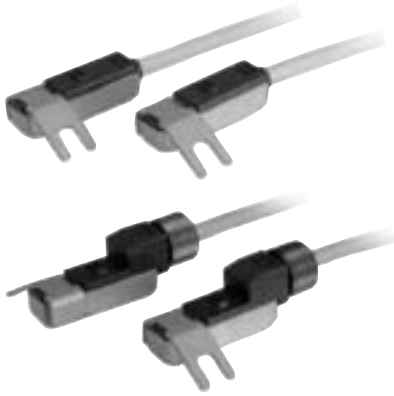

Auto switch internal circuits

Lead wire colors inside () are those prior to conformity with IEC standards.

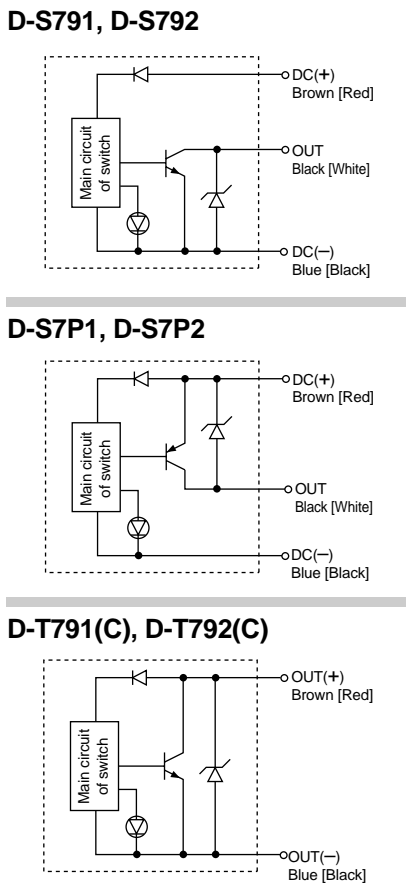

Specifications

D-S79, D-S7P, D-T79 (with indicator light)

Auto switch model no.	D-S791, D-S792	D-S7P1, D-S7P2	D-T791, D-T792, D-T791C, D-T792C
Wiring type	3-wire		2-wire
Output type	NPN	PNP	—
Applicable load	IC circuit, Relay, PLC		24VDC relay, PLC
Power supply voltage	5, 12, 24VDC (4.5 to 28VDC)		—
Current consumption	10mA or less		—
Load voltage	28VDC or less	—	24VDC (10 to 28VDC)
Load current	40mA or less	80mA or less	5 to 40mA
Internal voltage drop	1.5V or less (0.8V or less at 10mA load current)	0.8V or less	4V or less
Leakage current	100μA or less at 24VDC		0.8mA or less at 24VDC
Indicator light	Red LED lights up when ON		

• Lead wires — Oilproof heavy-duty vinyl cord, 0.5m, $\phi 3.4$, 0.2mm² x 3 cores [Brown, Black, Blue (Red, White, Black)]
0.2mm² x 2 cores [Brown, Blue (Red, Black)]

Note) Refer to page 91 for auto switch common specifications and for lead wire length.

Dimensions

D-S791: Right-hand type

D-S7P1:

D-S792: Left-hand type

D-S7P2:

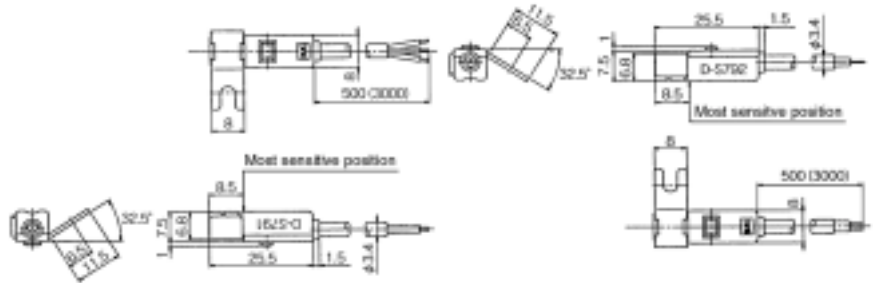

D-T791: Right-hand type

D-T792: Left-hand type

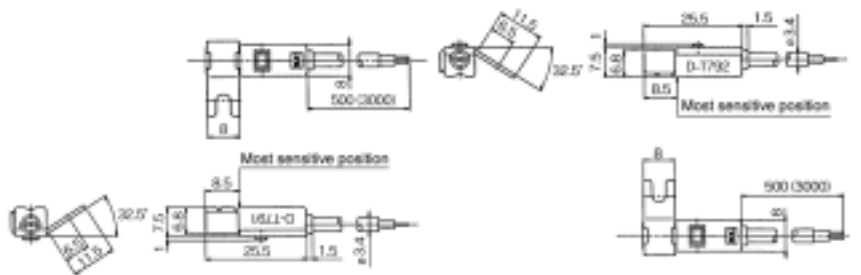

D-T791C: Right-hand type

D-T792C: Left-hand type

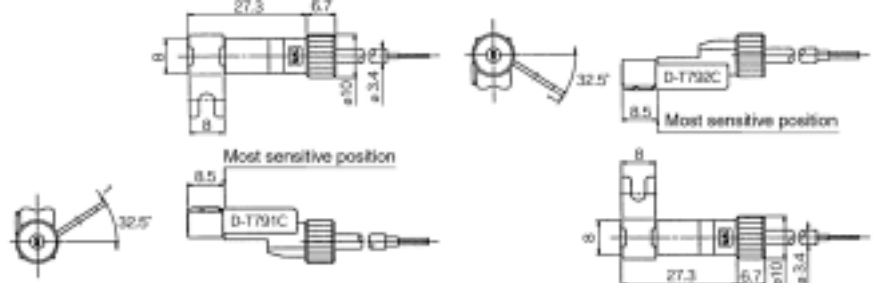

Series CRB2/CRBU2/CRB1 Model Selection

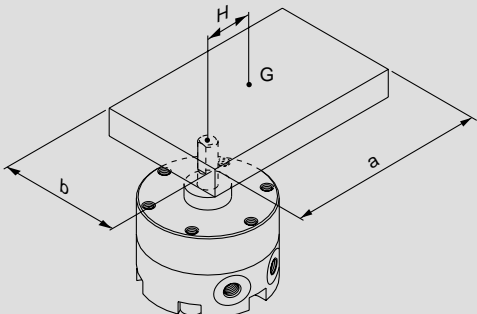
Selection Procedure	Formulas	Selection Example										
<p>1 Operating conditions</p> <p>List the operating conditions.</p>	<ul style="list-style-type: none"> • Model used • Operating pressure • Load types <ul style="list-style-type: none"> Ts (N·m) Tf (N·m) Ta (N·m) • Load configuration • Rotation time t (s) • Rotation • Load weight m (kg) • Distance between central axis and center of gravity H (mm) 	 <p>Rotary actuator: CRB2BW30-90S; Pressure: 0.5MPa Mounting orientation: Vertical; Type of load: Inertial load Ta Load configuration: 60mm x 40mm (rectangular plate) Rotation time (t): 0.3s; Rotation (θ): 90° Load weight (m): 0.15kg Distance between central axis and center of gravity (H): 30mm</p>										
<p>2 Required torque</p> <p>Confirm the type of load as shown below, and select an actuator that satisfies the required torque.</p> <ul style="list-style-type: none"> • Static load: Ts • Resistance load: Tf Load types • Inertial load: Ta 	<p>Effective torque ≥ Ts Effective torque ≥ (3 to 5)·Tf Effective torque ≥ 10·Ta Effective torque</p>	<p>Inertial load $10 \times Ta = 10 \times I \times \dot{\omega} = 10 \times 0.0002 \times \pi / 0.3^2$ $= 0.07\text{N}\cdot\text{m} < \text{Effective torque OK}$ Note) "I" substitutes for ⑤, the value for moment of inertia. $\dot{\omega} = \frac{2\theta}{t^2}$ (ω: Angular acceleration)</p>										
<p>3 Rotation time</p> <p>Confirm that it is within the adjustable range of rotation time.</p>	<table border="1"> <thead> <tr> <th>Model</th> <th>Rotation time adjustment range for stable operation S/90°</th> </tr> </thead> <tbody> <tr> <td>CRB2BW/CRBU2W10, 20</td> <td>0.03 to 0.3</td> </tr> <tr> <td>CRB2BW/CRBU2W30</td> <td>0.04 to 0.3</td> </tr> <tr> <td>CRB2BW/CRBU2W40</td> <td>0.07 to 0.5</td> </tr> <tr> <td>CRB1BW50 to 100</td> <td>0.1 to 1</td> </tr> </tbody> </table>	Model	Rotation time adjustment range for stable operation S/90°	CRB2BW/CRBU2W10, 20	0.03 to 0.3	CRB2BW/CRBU2W30	0.04 to 0.3	CRB2BW/CRBU2W40	0.07 to 0.5	CRB1BW50 to 100	0.1 to 1	<p>0.3s/90° OK</p>
Model	Rotation time adjustment range for stable operation S/90°											
CRB2BW/CRBU2W10, 20	0.03 to 0.3											
CRB2BW/CRBU2W30	0.04 to 0.3											
CRB2BW/CRBU2W40	0.07 to 0.5											
CRB1BW50 to 100	0.1 to 1											
<p>4 Allowable load</p> <p>Confirm that the radial load, thrust load, and moment are within the allowable ranges.</p>	<p>Thrust load: $m \times 9.8 \leq \text{Allowable load}$ Allowable load</p>	<p>$0.15 \times 9.8 = 1.47\text{N} < \text{Allowable load OK}$</p>										
<p>5 Inertial moment</p> <p>Find the load's inertial moment "I" for the energy calculation.</p>	<p>$I = m \times (a^2 + b^2) / 12 + m \times H^2$ Inertial moment</p>	<p>$I = 0.15 \times (0.06^2 + 0.04^2) / 12 + 0.15 \times 0.03^2$ $= 0.0002\text{kg}\cdot\text{m}^2$</p>										
<p>6 Kinetic energy</p> <p>Confirm that the load's kinetic energy is within the allowable value.</p>	<p>$1/2 \times I \times \dot{\omega}^2 < \text{Allowable energy}$ $\dot{\omega} = 2\theta / t$ (ω: Terminal angular velocity) θ: Rotation angle (rad) t: Rotation time (s) Allowable kinetic energy/Rotation time</p>	<p>$1/2 \times (0.0002) \times (2 \times (\pi/2) / 0.3)^2 =$ $0.01096\text{J} < \text{Allowable energy OK}$</p>										

Effective Torque

Unit: N·m

Size	Vane type	Operating pressure (MPa)									
		0.15	0.2	0.3	0.4	0.5	0.6	0.7	0.8	0.9	1.0
10	Single vane	—	0.03	0.06	0.09	0.12	0.15	0.18	—	—	—
	Double vane	—	0.07	0.13	0.19	0.25	0.31	0.37	—	—	—
15	Single vane	0.06	0.10	0.17	0.24	0.32	0.39	0.46	—	—	—
	Double vane	0.13	0.20	0.34	0.48	0.65	0.79	0.93	—	—	—
20	Single vane	0.16	0.23	0.39	0.54	0.70	0.84	0.99	—	—	—
	Double vane	0.33	0.47	0.81	1.13	1.45	1.76	2.06	—	—	—
30	Single vane	0.44	0.62	1.04	1.39	1.83	2.19	2.58	3.03	3.40	3.73
	Double vane	0.90	1.26	2.10	2.80	3.70	4.40	5.20	6.09	6.83	7.49
40	Single vane	0.81	1.21	2.07	2.90	3.73	4.55	5.38	6.20	7.03	7.86
	Double vane	1.78	2.58	4.3	5.94	7.59	9.24	10.89	12.5	14.1	15.8
50	Single vane	1.20	1.86	3.14	4.46	5.69	6.92	8.14	9.5	10.7	11.9
	Double vane	2.70	4.02	6.60	9.21	11.8	14.3	16.7	19.4	21.8	24.2
63	Single vane	2.59	3.77	6.11	8.45	10.8	13.1	15.5	17.8	20.2	22.5
	Double vane	5.85	8.28	13.1	17.9	22.7	27.5	32.3	37.10	41.9	46.7
80	Single vane	4.26	6.18	10.4	14.2	18.0	21.9	25.7	30.0	33.8	37.6
	Double vane	8.70	12.6	21.1	28.8	36.5	44.2	51.8	60.4	68.0	75.6
100	Single vane	8.6	12.2	20.6	28.3	35.9	43.6	51.2	59.7	67.3	75
	Double vane	17.9	25.2	42.0	57.3	72.6	87.9	103	120	135	150

Load Types

• Static load: Ts

Definition for our purposes:

A load that requires pressing force only, as represented by the clamp.

(If the mass of the clamp itself in the drawing below is considered in the calculations, it should be regarded as an inertial load.)

(Example)

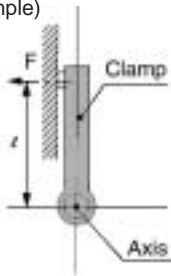

F: Pressing force (N)
Static torque calculation
 $T_s = F \times L$ (N·m)

• Static load: Ts

Definition for our purposes:

A load that is affected by external forces such as friction or gravity. Since the purpose is to move the load, and speed adjustment is necessary, allow an extra margin of 3 to 5 times in the effective torque.

* Actuator effective torque $\geq (3 \text{ to } 5) \times T_f$

(If the mass of the lever itself in the drawing below is considered in the calculations, it should be regarded as an inertial load.)

(Example)

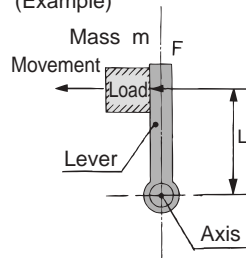

Friction coefficient: μ

$$F = \mu mg$$

Static torque calculation

$$T_f = F \times L \text{ (N·m)}$$

$$g = 9.8 \text{ m/s}^2$$

• Inertial load: Ta

Definition for our purposes:

A load that is actually rotated by the actuator. Since the purpose is to rotate the load, and speed adjustment is necessary, allow an extra margin of 10 times or more in the effective torque.

* Actuator effective torque $\geq S \times T_a$
(S is 10 times or more).

Accelerating torque calculation

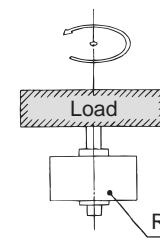

$$T_a = I \cdot \dot{\omega} \text{ (N·m)}$$

I: Inertial moment
Refer to page 100.

$\dot{\omega}$: Angular acceleration

$$\dot{\omega} = \frac{2\theta}{t^2} \text{ (rad/s}^2\text{)}$$

θ : Rotation angle (rad)

t: Rotation time (S)

Allowable Load

Application of the load on the axial direction is tolerated if no dynamic load is generated and the values are within what is shown in the table below. However, avoid such operation that the load is applied directly to the shaft.

Unit: N

Model	Load direction		
	Fsa	Fsb	Fr
CRB2BW, CRBU2W10	9.8	9.8	14.7
CRB2BW, CRBU2W15	9.8	9.8	14.7
CRB2BW, CRBU2W20	19.6	19.6	24.5
CRB2BW, CRBU2W30	24.5	24.5	29.4
CRB2BW, CRBU2W40	40	40	60
CRB1BW50	196	196	245
CRB1BW63	340	340	390
CRB1BW80	490	490	490
CRB1BW100	539	539	588

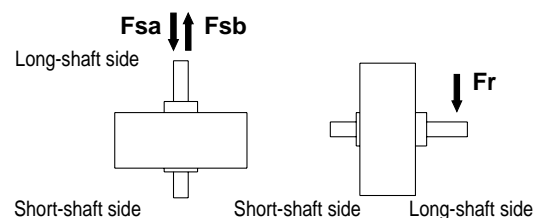

Inertial Moment

I: Inertial moment kg·m²; m: Load weight kg

1. Thin shaft

Position of rotational axis: Perpendicular to the shaft anywhere along its length

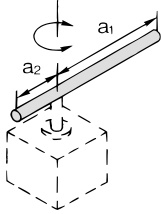

$$I = m_1 \cdot \frac{a_1^2}{3} + m_2 \cdot \frac{a_2^2}{3}$$

2. Thin shaft

Position of rotational axis: Through the shaft's center of gravity

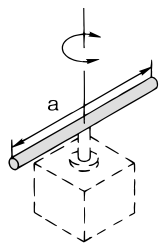

$$I = m \cdot \frac{a^2}{12}$$

3. Thin rectangular plate (rectangular parallelepiped)

Position of rotational axis: Through the plate's center of gravity

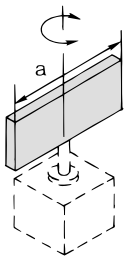

$$I = m \cdot \frac{a^2}{12}$$

4. Thin rectangular plate (rectangular parallelepiped)

Position of rotational axis: Perpendicular to the plate through one end (also the same in case of a thicker plate)

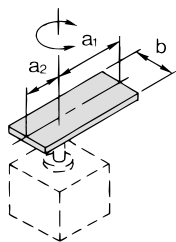

$$I = m_1 \cdot \frac{4a_1^2 + b^2}{12} + m_2 \cdot \frac{4a_2^2 + b^2}{12}$$

5. Thin rectangular plate (rectangular parallelepiped)

Position of rotational axis: Through the center of gravity and perpendicular to the plate (also the same in case of a thicker plate)

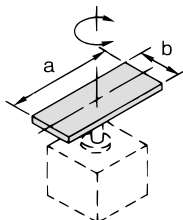

$$I = m \cdot \frac{a^2 + b^2}{12}$$

6. Cylinder (including thin round plate)

Position of rotational axis: Through the plate's central axis

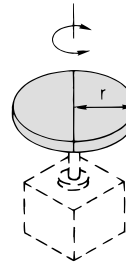

$$I = m \cdot \frac{r^2}{2}$$

7. Solid sphere

Position of rotational axis: Through the sphere's diameter

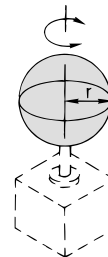

$$I = m \cdot \frac{2r^2}{5}$$

8. Thin round plate

Position of rotational axis: Through the plate's diameter

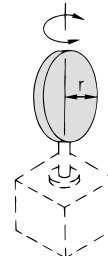

$$I = m \cdot \frac{r^2}{4}$$

9. Load at the end of lever

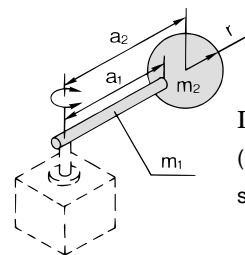

$$I = m_1 \cdot \frac{a_1^2}{3} + m_2 \cdot a_2^2 + K$$

(Example) When the shape of m_2 is a sphere, refer to 7 above: $w K = m_2 \cdot \frac{2r^2}{5}$

10. Gear transmission

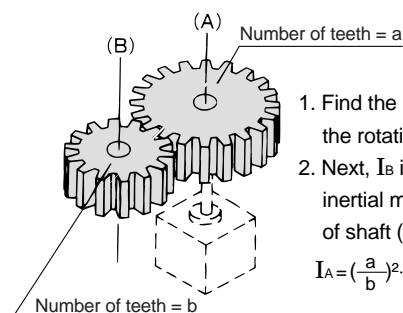

1. Find the inertial moment I_B for the rotation of shaft (B).
2. Next, I_B is entered to find the inertial moment I_A for the rotation of shaft (A) as

$$I_A = \left(\frac{a}{b}\right)^2 \cdot I_B$$

Kinetic Energy/Rotation Time

Even in cases where the torque required for rotation of the load is small, damage to internal parts may result from the inertial force of the load.

Take into account the load's inertial moment, kinetic energy, and rotation time during operation when making your model selection. (The inertial moment and rotation time charts can be used for your convenience in making model selections.)

1. Allowable kinetic energy and rotation time adjustment range

From the table below, set the rotation time within the proper adjustment range for stable operation. Note that slow speed operation exceeding the rotation time adjustment time range may lead to sticking or stopping of operation.

CRB2BW, CRBU2W: Sizes 10 to 40

Model	Allowable kinetic energy (J)		Rotation time adjustment range for stable operation (s/90°)
	Single vane	Double vane	
CRB2BW10, CRBU2W10	0.00015	0.003	0.03 to 0.3
CRB2BW15, CRBU2W15	0.001	0.0012	
CRB2BW20, CRBU2W20	0.003	0.0033	
CRB2BW30, CRBU2W30	0.02		0.04 to 0.3
CRB2BW40, CRBU2W40	0.04		0.07 to 0.5

CRB1BW: Sizes 50 to 100

Model	Allowable kinetic energy (J)		Rotation time adjustment range for stable operation (s/90°)
	Single vane	Double vane	
CRB1BW50	0.082	0.112	0.1 to 1
CRB1BW63	0.12	0.16	
CRB1BW80	0.398	0.54	
CRB1BW100	0.6	0.811	

2. Inertial moment calculation

Since the formula for inertial moment differs depending on the configuration of the load, refer to the inertial moment calculation formulas on the preceding page.

3. Model selection

Select models by applying the inertial moment and rotation time that you have calculated to the chart below.

CRB2BW, CRBU2W: Sizes 10 to 40

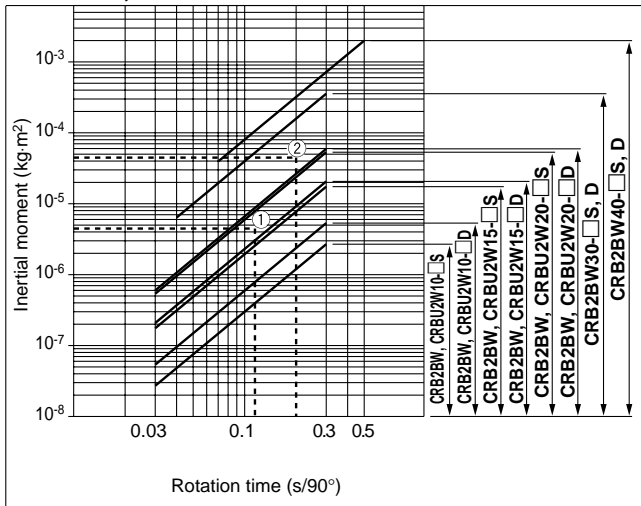

CRB1BW: Sizes 50 to 100

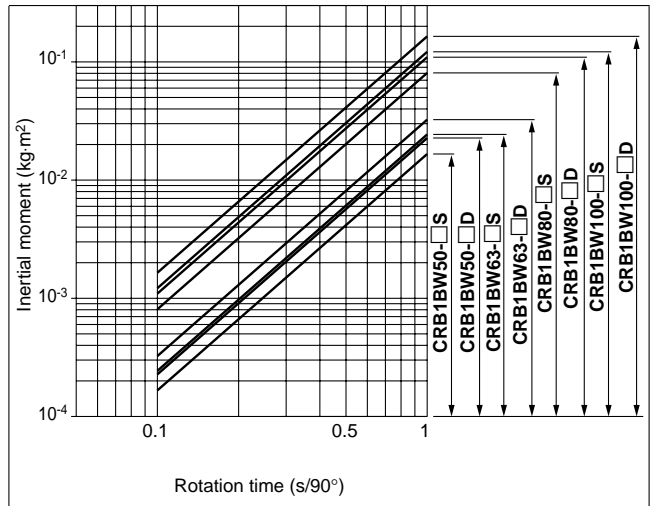

1. <How to read the chart>

- Inertial moment $3.5 \times 10^{-6} \text{ kg}\cdot\text{m}^2$
 - Rotation time $0.12\text{s}/90^\circ$
- CRB2BW, CRBU2W20 are selected in this case.

2. <Calculation example>

Load configuration: A cylinder of radius 0.03m and mass 0.1kg
Rotation time: $0.2\text{s}/90^\circ$

$$I = 0.1 \times \frac{0.03^2}{2} = 4.5 \times 10^{-5} \text{ kg}\cdot\text{m}^2$$

In the inertial moment and rotation time chart, find the intersection of the lines extended from the points corresponding to $4.5 \times 10^{-5} \text{ kg}\cdot\text{m}^2$ on the vertical axis (inertial moment) and $0.2\text{s}/90^\circ$ on the horizontal axis (rotation time).

Since the resulting intersection point falls within the CRB2BW30 and CRBU2W30 selection range, CRB2BW30, CRBU2W30, CRB2BW40, or CRBU2W40 may be selected.

How to calculate the kinetic energy of the load

$$E = \frac{1}{2} \cdot I \cdot \omega^2, \quad \omega = \frac{2\theta}{t}$$

E: Kinetic energy (J)

I: Inertial moment of the load ($\text{kg}\cdot\text{m}^2$)

* ω : Angular speed (rad/s)

θ : Rotation (rad)

$$180^\circ = 3.14\text{rad}$$

t: Rotation time (s)

* ω calculated using this formula is the angular speed at the end for equiangular accelerated motion.

Series CRB2/CRBU2/CRB1

Air Consumption/Required Air Capacity

Air Consumption

Air consumption is the volume of air that is expended by the rotary actuator's reciprocal operation inside the actuator and in the piping between the actuator and the switching valve. It is required for selection of a compressor and for calculation of its running cost.

* The air consumption (Q_{CR}) required for one reciprocation of a single rotary actuator alone is shown in the table below, and can be used to simplify the calculation.

Formulas

Q_{CR}: When the internal volume of a rotary actuator varies depending on the A and B ports, use formula (1).

$$Q_{CR} = V \times \left(\frac{P + 0.1}{0.1} \right) \times 10^{-3} \dots \dots \dots \text{Formula (1)}$$

$$Q_{CR} = 2V \times \left(\frac{P + 0.1}{0.1} \right) \times 10^{-3} \dots \dots \dots \text{Formula (2)}$$

$$Q_{CP} = 2 \times a \times L \times \frac{P}{0.1} \times 10^{-6} \dots \dots \dots \text{Formula (3)}$$

$$Q_C = Q_{CR} + Q_{CP} \dots \dots \dots \text{Formula (4)}$$

- Q_{CR} = Air consumption of rotary actuator [L (ANR)]
- Q_{CP} = Air consumption of tubing or piping [L (ANR)]
- V = Internal volume of rotary actuator [cm³]
- P = Operating pressure [MPa]
- L = Piping length [mm]
- a = Internal cross section of piping [mm²]
- Q_C = Air consumption required for one reciprocation of rotary actuator [L (ANR)]

When selecting a compressor, it is necessary to choose one that has sufficient reserve for the total downstream air consumption of all pneumatic actuators. This is affected by factors such as leakage in piping, consumption by drain valves and pilot valves, and reduction of air volume due to temperature drops.

Formula

$$Q_{C2} = Q_C \times n \times \text{Number of actuators} \times \text{Reserve factor} \dots \dots \dots \text{Formula (5)}$$

- Q_{C2} = Compressor discharge flow rate [L/min (ANR)]
- n = Actuator reciprocations per minute
- Reserve factor = 1.5 or more

Internal cross section of tubing and steel piping

Nominal size	O.D. (mm)	I.D. (mm)	Internal cross section a (mm ²)
T□ 0425	4	2.5	4.9
T□ 0604	6	4	12.6
TU 0805	8	5	19.6
T□ 0806	8	6	28.3
1/8B	—	6.5	33.2
T□ 1075	10	7.5	44.2
TU 1208	12	8	50.3
T□ 1209	12	9	63.6
1/4B	—	9.2	66.5
TS 1612	16	12	113
3/8B	—	12.7	127
T□ 1613	16	13	133
1/2B	—	16.1	204

Required Air Capacity

Required air capacity is the volume of air that is required to operate the rotary actuator at a certain speed. It is required for selection of an air preparation equipment and piping size.

Formula

$$Q_R = 30 \times \frac{Q_C}{t} \dots \dots \dots \text{Formula (6)}$$

- Q_R = Required air capacity [L/min (ANR)]
- Q_C = Air consumption required for one reciprocation of rotary actuator [L (ANR)]
..... Formula (4)
- t = Rotation time (one-way) of rotary actuator [s]

Air Consumption

<Table 1> CRB2, CRBU2, CRB1

Unit: L (ANR)

Vane type	Size	Rotation	Volume: V(cm ³)		Operating pressure (MPa)									
			Pressurized port: A	Pressurized port: B	0.15	0.2	0.3	0.4	0.5	0.6	0.7	0.8	0.9	1.0
Single vane	10	90	0.6	1.0	—	0.005	0.006	0.008	0.009	0.011	0.013	—	—	—
		180	1.2		—	0.007	0.010	0.012	0.014	0.017	0.019	—	—	—
		270	1.5		—	0.009	0.012	0.015	0.018	0.021	0.024	—	—	—
	15	90	1.0	1.5	0.006	0.007	0.010	0.012	0.015	0.017	0.020	—	—	—
		180	2.9		0.014	0.017	0.023	0.029	0.034	0.040	0.046	—	—	—
		270	3.7		0.018	0.022	0.029	0.037	0.044	0.051	0.059	—	—	—
	20	90	3.6	4.8	0.021	0.025	0.033	0.042	0.050	0.058	0.066	—	—	—
		180	6.1		0.030	0.036	0.048	0.060	0.072	0.084	0.097	—	—	—
		270	7.9		0.039	0.047	0.063	0.078	0.094	0.109	0.125	—	—	—
	30	90	8.5	11.3	0.049	0.059	0.078	0.098	0.118	0.137	0.157	0.176	0.196	0.215
		180	15		0.074	0.089	0.119	0.148	0.178	0.208	0.237	0.267	0.297	0.326
		270	20.2		0.100	0.120	0.160	0.200	0.240	0.280	0.320	0.359	0.399	0.439
	40	90	21	25	0.114	0.137	0.182	0.228	0.273	0.318	0.364	0.409	0.455	0.500
		180	31.5		0.156	0.187	0.250	0.312	0.374	0.436	0.498	0.561	0.623	0.685
		270	41		0.203	0.244	0.325	0.406	0.487	0.568	0.649	0.730	0.811	0.891
	50	90	30		0.149	0.178	0.238	0.297	0.356	0.415	0.475	0.534	0.593	0.652
		100	32		0.159	0.190	0.254	0.317	0.380	0.443	0.506	0.569	0.633	0.696
		180	49		0.243	0.291	0.388	0.485	0.582	0.678	0.775	0.872	0.969	1.065
		190	51		0.253	0.303	0.404	0.505	0.605	0.706	0.807	0.908	1.008	1.109
		270	66		0.327	0.393	0.523	0.653	0.784	0.914	1.044	1.174	1.305	1.435
		280	68		0.337	0.405	0.539	0.673	0.807	0.942	1.076	1.210	1.344	1.479
	63	90	70		0.347	0.416	0.555	0.693	0.831	0.969	1.107	1.246	1.384	1.522
		100	73		0.362	0.434	0.578	0.723	0.867	1.011	1.155	1.299	1.443	1.587
		180	94		0.466	0.559	0.745	0.930	1.116	1.302	1.487	1.673	1.858	2.044
		190	97		0.481	0.577	0.769	0.960	1.152	1.343	1.535	1.726	1.918	2.109
		270	118		0.585	0.702	0.935	1.168	1.401	1.634	1.867	2.100	2.333	2.566
		280	121		0.600	0.720	0.959	1.198	1.436	1.675	1.914	2.153	2.392	2.631
	80	90	88		0.437	0.523	0.697	0.871	1.045	1.218	1.392	1.566	1.740	1.913
		100	93		0.461	0.553	0.737	0.920	1.104	1.288	1.471	1.655	1.839	2.022
		180	138		0.685	0.821	1.093	1.366	1.638	1.911	2.183	2.456	2.728	3.001
190		143		0.709	0.851	1.133	1.415	1.698	1.980	2.262	2.545	2.827	3.109	
270		188		0.933	1.118	1.490	1.861	2.232	2.603	2.974	3.345	3.717	4.088	
280		193		0.958	1.148	1.529	1.910	2.291	2.672	3.053	3.434	3.815	4.196	
100	90	186		0.923	1.106	1.474	1.841	2.208	2.575	2.943	3.310	3.677	4.044	
	100	197		0.977	1.172	1.561	1.950	2.339	2.728	3.117	3.506	3.894	4.283	
	180	281		1.394	1.672	2.226	2.781	3.336	3.891	4.446	5.000	5.555	6.110	
	190	292		1.449	1.737	2.314	2.890	3.467	4.043	4.620	5.196	5.773	6.349	
	270	376		1.866	2.237	2.979	3.721	4.464	5.206	5.948	6.691	7.433	8.175	
	280	387		1.920	2.302	3.066	3.830	4.594	5.358	6.122	6.887	7.651	8.415	
Double vane	10	90	1.0		—	0.006	0.008	0.010	0.012	0.014	0.016	—	—	—
		100	1.1		—	0.007	0.009	0.011	0.013	0.015	0.017	—	—	—
	15	90	2.6		0.013	0.015	0.021	0.026	0.031	0.036	0.041	—	—	—
		100	2.7		0.013	0.016	0.021	0.027	0.032	0.037	0.043	—	—	—
	20	90	5.6		0.028	0.033	0.044	0.055	0.066	0.078	0.089	—	—	—
		100	5.7		0.028	0.034	0.045	0.056	0.068	0.079	0.090	—	—	—
	30	90	14.4		0.071	0.086	0.114	0.143	0.171	0.199	0.228	0.256	0.285	0.313
		100	14.5		0.072	0.086	0.115	0.144	0.172	0.201	0.229	0.258	0.287	0.315
	40	90	33		0.164	0.196	0.261	0.327	0.392	0.457	0.522	0.587	0.652	0.718
		100	34		0.169	0.202	0.269	0.337	0.404	0.471	0.538	0.605	0.672	0.739
	50	90	48		0.238	0.286	0.380	0.475	0.570	0.665	0.759	0.854	0.949	1.044
		100	52		0.258	0.309	0.412	0.515	0.617	0.720	0.823	0.925	1.028	1.131
	63	90	98		0.486	0.583	0.776	0.970	1.163	1.357	1.550	1.744	1.937	2.131
		100	104		0.516	0.619	0.824	1.029	1.235	1.440	1.645	1.851	2.056	2.261
	80	90	136		0.675	0.809	1.078	1.346	1.615	1.883	2.152	2.420	2.689	2.957
		100	146		0.724	0.869	1.157	1.445	1.733	2.022	2.310	2.598	2.886	3.175
	100	90	272		1.350	1.618	2.155	2.692	3.229	3.766	4.303	4.840	5.377	5.914
		100	294		1.459	1.749	2.329	2.910	3.490	4.071	4.651	5.232	5.812	6.393



Series *CRB2/CRBU2/CRB1* Safety Instructions

These safety instructions are intended to prevent a hazardous situation and/or equipment damage. These instructions indicate the level of potential hazard by a label of "**Caution**", "**Warning**", or "**Danger**". To ensure safety, be sure to observe ISO 4414 Note 1), JIS B 8370 Note 2) and other safety practices.

 **Caution** : Operator error could result in injury or equipment damage.

 **Warning** : Operator error could result in serious injury or loss of life.

 **Danger** : In extreme conditions, there is a possible result of serious injury or loss of life.

Note 1) ISO 4414: Pneumatic fluid power – Recommendations for the application of equipment to transmission and control systems

Note 2) JIS B 8370: General Rules for Pneumatic Equipment

Warning

1. The compatibility of pneumatic equipment is the responsibility of the person who designs the pneumatic system or decides its specifications.

Since the products specified here are used in various operating conditions, their compatibility with the specific pneumatic system must be based on specifications or after analysis and/or tests to meet your specific requirements.

2. Only trained personnel should operate pneumatically operated machinery and equipment.

Compressed air can be dangerous if handled incorrectly. Assembly, handling or repair of pneumatic systems should be performed by trained and experienced operators.

3. Do not service machinery/equipment or attempt to remove components until safety is confirmed.

1. Inspection and maintenance of machinery/equipment should only be performed after confirmation of safe locked-out control positions.
2. When equipment is to be removed, confirm the safety process as mentioned above. Cut the supply pressure for this equipment and exhaust all residual compressed air in the system.
3. Before machinery/equipment is restarted, take measures to prevent shooting-out of cylinder piston rod, etc. (Bleed air into the system gradually to create back pressure.)

4. Contact SMC if the product is to be used in any of the following conditions:

1. Conditions and environments beyond the given specifications, or if product is used outdoors.
2. Installation on equipment in conjunction with atomic energy, railway, air navigation, vehicles, medical equipment, food and beverages, recreation equipment, emergency stop circuits, press applications, or safety equipment.
3. An application which has the possibility of having negative effects on people, property, or animals, requiring special safety analysis.



Series CRB2/CRBU2/CRB1

Rotary Actuator Precautions 1

Be sure to read before handling.

Design

⚠ Warning

1. **The machinery should be designed to ensure a safety for load variations, lifting/lowering operations, or changes in frictional resistance.**

Operating speed will increase, and bodily injury may occur, or damage to the machinery itself may occur.

2. **A protective cover is recommended to minimize the risk of personal injury.**

If a driven object and moving parts of an actuator pose a danger of personal injury, design the structure to avoid contact with the human body.

3. **Securely tighten all stationary parts and connected parts so that they will not become loose.**

Particularly when a rotary actuator operates with high frequency or is installed where there is a lot of vibration, ensure that all parts remain secure.

4. **A shock absorber may be required.**

When a driven object is operated at high speed or the load is heavy, there is a danger of exceeding the allowable kinetic energy of the rotary actuator. Therefore, install an external shock absorber to relieve the impact before reaching the end of rotation. In this case, the rigidity of the machinery should also be examined.

5. **Take into account a possible drop in operating pressure due to a power outage.**

When an actuator is used as clamping mechanism, there is a danger of work piece dropping if there is a decrease in clamping force due to a drop in circuit pressure caused by a power outage. Therefore, safety equipment should be installed to prevent damage to machinery and bodily injury.

6. **Take into account a possible loss of power source.**

Measures should be taken to protect against bodily injury and equipment damage in the event that there is a loss of power to equipment controlled by pneumatics, electricity, or hydraulics.

7. **Design circuitry that takes residual pressure into a consideration when a speed controller is installed at exhaust side.**

If the supply side is pressurized when there is no residual pressure on the exhaust side, the actuator may operate abnormally fast and this can cause bodily injury, and/or damage to equipment.

8. **Take into account emergency stops.**

Design the system so that bodily injury and/or damage to machinery and equipment will not occur when machinery is stopped by a manual emergency stop or a safety device triggered by abnormal conditions such as a power outage.

9. **Take into account the action of the system when operation is restarted after an emergency stop or abnormal stop.**

Design machinery so that bodily injury or equipment damage will not occur upon restart of operation.

When the actuator has to be reset at the starting position, install safe manual control equipment.

Design

⚠ Warning

10. **Do not use this product as a shock absorbing mechanism.**

If abnormal pressure or leakage occurs, there may be a drastic loss of deceleration effectiveness, leading to danger of bodily injury as well as damage to equipment and machinery.

Selection

⚠ Warning

1. **Keep the speed setting within the product's allowable energy value.**

Operating with the kinetic energy of the load exceeding the allowable value can damage to the product, leading to bodily injury as well as damage to equipment and machinery.

2. **Provide a shock absorbing mechanism when kinetic energy applied to the product exceeds the allowable value.**

Operation of the actuator exceeding its allowable kinetic energy can damage the product, leading to bodily injury and damage to equipment and machinery.

3. **Do not perform intermediate stop or holding operations by trapping air pressure inside the actuator.**

If the operation of the actuator without an external stop mechanism is stopped at an intermediate position by trapping air pressure with a directional control valve, the stopping position may not be hold due to leakage. This can cause bodily injury and damage to equipment and machinery.

⚠ Caution

1. **Do not operate the product at low speeds that are below the prescribed speed adjustment range.**

Operating at low speeds below the speed adjustment range may cause sticking and slipping or stopping of operation.

2. **Do not apply external torque that exceeds the product's rated output.**

Applying external force exceeding the product's rated output can damage the actuator.

3. **When repeatability of the rotation angle is required, the load should be directly stopped externally.**

The initial rotation angle may vary even for the actuator equipped with angle adjustment.

4. **Avoid operation with hydraulic system.**

Operation on hydraulic systems can damage the product.

5. **Allow a torque margin for the actuator when the load variations are anticipated.**

When the actuator is mounted horizontally (i.e., the actuator is in a lateral direction), load variations can cause adverse effects to the actuator.



Series CRB2/CRBU2/CRB1 Rotary Actuator Precautions 2

Be sure to read before handling.

Mounting

⚠ Warning

1. Be sure to keep equipment from rotating any more than necessary when the angle is adjusted by supplying pressure.

When the angle is adjusted by supplying air, the actuator may rotate and fall during the adjustment depending on its mounting orientation. This can cause bodily injury and damage to equipment and machinery.

2. Do not loosen the angle adjustment screw beyond the adjustment range.

Loosening the angle adjustment screw past the adjustment range can cause the screw to come out causing bodily injury and damage to equipment and machinery.

3. Do not allow external magnetism near the actuator.

Since the auto switches are sensitive to magnetism, external magnetism in close proximity to the actuator can cause malfunction leading to bodily injury and damage to equipment and machinery.

4. Do not perform additional machining on the product.

Additional machining of the product can adversely affect product strength and damage the actuator, leading to bodily injury and damage to equipment and machinery.

5. Do not enlarge the fixed restrictor on the piping port by remachining.

Enlarging the bore size will increase the rotation speed and impact force. This can damage the actuator leading to bodily injury and damage to equipment and machinery.

6. Avoid direct connection with output shaft, but rather align using a shaft coupling with a sufficient degree of freedom to absorb the decenter and deflection angle when using on the load side.

Directly connecting a bearing and output shaft will cause twisting due to the decenter and deflection angle, and this can cause a malfunction leading to bodily injury and damage to equipment and machinery.

7. Do not apply loads to the shaft exceeding the values shown on page 99.

Applying loads exceeding the allowable values to the actuator can cause the actuator to malfunction and leading to bodily injury and damage to equipment and machinery.

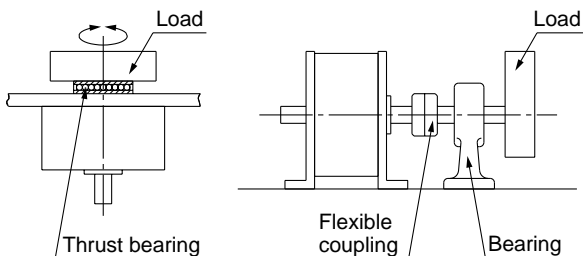

A load up to the allowable radial/thrust load can be applied provided that a dynamic load is not generated. However, applications that a load is directly applied to the shaft should be avoided whenever possible. In order to further improve operating conditions, methods such as shown in the drawings above are recommended so that the direct load is not applied to the shaft.

⚠ Warning

8. Install external stoppers away from the axis of rotation.

If the stopper is installed close to the axis of rotation, the reactive force operating on the stopper due to torque generated by the actuator itself will be applied to the shaft. This can damage the shaft and bearing, leading to bodily injury and damage to equipment and machinery.

Precautions when using external stoppers

When the kinetic energy generated by the load exceeds the limit value of the actuator, an external absorbing mechanism must be provided to absorb the energy.

The figure below illustrates the correct mounting of the external stopper.

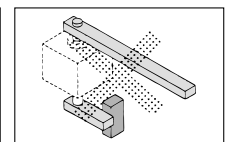
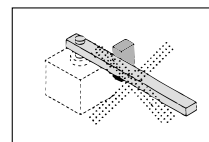
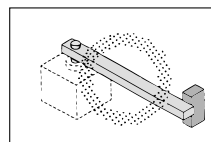
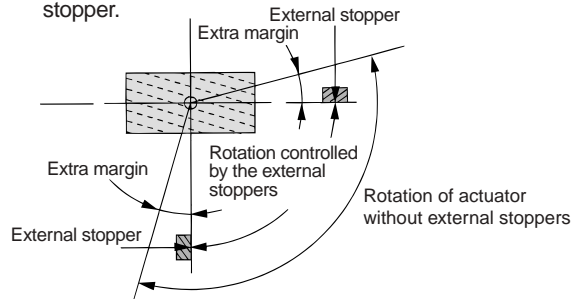

External stopper becomes a fulcrum, and the load's inertial force is applied to the shaft as a bending moment.

If an external stopper is installed on the shaft side opposite the load, the inertial force generated by the load is applied directly to the shaft.

⚠ Caution

1. Secure the block of the angle adjustment unit using the specified torque range.

Using a tightening torque below the specified value can cause the block to slip out of position and exceed its set angle during operation.

2. Do not wipe the model number on the label with solutions such as organic solvents.

Using such solutions to wipe the label can erase the model numbers.

3. Do not strike the shaft while the body is secured, or strike the body while the shaft is secured.

This can bend the shaft and damage the bearing. Secure the shaft when installing a load on the shaft.

4. Do not step directly on the shaft or the equipment installed on the shaft.

Stepping directly on the shaft can damage the shaft and bearing.

5. Operate the actuator with the angle adjustment mechanism within the specified adjustment range.

Operating beyond the adjustment range can cause malfunctioning and damage to the actuator. Refer to product specifications for the adjustment range of each product.



Series CRB2/CRBU2/CRB1

Rotary Actuator Precautions 3

Be sure to read before handling.

Air Supply

Warning

1. Use clean air.

Do not use compressed air which contains chemicals, synthetic oils containing organic solvents, salt, or corrosive gases, as this can cause damage or malfunction.

Caution

1. Install air filters.

Install air filters at the inlet side of valves. The filtration degree should be 5 μ m or finer.

2. Install an after-cooler, air dryer, or water separator (Drain Catch).

Compressed air that includes excessive drainage or condensate may cause malfunction of rotary actuators and other pneumatic equipment. To prevent this, install an after-cooler, air dryer, or water separator (Drain Catch).

3. Use the product within the specified range of fluid and ambient temperature.

Take measures to prevent freezing since moisture in circuits can freeze at, or below 5°C, and this can cause damage to seals and lead to malfunctions.

Refer to SMC's "Air Cleaning Equipment" catalog for further details on compressed air quality.

Operating Environment

Warning

1. Do not use in environments where there is a danger of corrosion.

Refer to the construction drawings regarding materials of rotary actuators.

2. Do not use in dusty environments or where exposure to water and oil spray or splash are expected.

Speed Adjustment

Warning

1. Adjust the speed gradually increasing from a low speed to the desired setting.

Adjusting the speed from a high speed can damage machinery and bodily injury.

Lubrication

Caution

1. Operate without lubrication from a pneumatic system lubricator. The actuator can be operated with lubrication; however, stick-slip will occur.

Maintenance

Warning

1. Perform maintenance inspection according to the procedure indicated in the instructional manual. Improper handling and maintenance may cause malfunctioning and damage of machinery or equipment to occur.

2. Do not disassemble the actuator while the power and supply air are turned on during maintenance inspection.

3. Conduct suitable function tests after the product has been disassembled for maintenance inspection.

Failure to test functions can result in inability to satisfy the product specifications.

Caution

1. For lubrication, use the grease specified for each product.

The use of a lubricant other than specified can cause damage to seals.



Series CRB2/CRBU2/CRB1

Auto Switch Precautions 1

Be sure to read before handling.

Design and Selection

Warning

1. Confirm the specifications.

Read the specifications carefully and use the product appropriately. The product may be damaged or malfunction if it is used outside the range of specifications of load current, voltage, temperature, or impact.

2. Take precautions when multiple actuators are used close together.

When two or more auto switch actuators are lined up in close proximity to each other, magnetic field interference may cause the switches to malfunction. Maintain a minimum actuator separation of 10mm. (When the allowable interval is specified for each actuator series, use the indicated value.)

3. Keep wiring as short as possible.

<Reed switches>

As the length of the wiring to a load gets longer, the rush current at switching on becomes greater, and this may shorten the product's life. (The switch will stay on all the time.)

- 1) For an auto switch without a contact protection circuit, use a contact protection box when the wire length is 5m or longer.
- 2) Even when an auto switch has a built-in contact protection circuit, if the lead wire length is 30m or more, the rush current cannot be adequately absorbed and the life of the switch may be shortened. Contact SMC in this case, as it will be necessary to connect a contact protection box to extend the life of the switch.

<Solid state switches>

- 3) Although wire length should not affect switch function, use a wire that is 100m or shorter.

4. Monitor the internal voltage drop of the switch.

<Reed switches>

- 1) Switches with an indicator light
 - If auto switches are connected in series as shown below, take note that there will be a large voltage drop because of internal resistance in the light emitting diodes. (Refer to internal voltage drop in the auto switch specifications.)

[The voltage drop will be "n" times larger when "n" auto switches are connected.]

Even though an auto switch operates normally, the load may not operate.

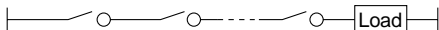

- Similarly, when operating below a specified voltage, it is possible that the load may be ineffective even though the auto switch function is normal. Therefore, the formula below should be satisfied after confirming the minimum operating voltage of the load.

$$\text{Supply voltage} - \text{Internal voltage drop of switch} > \text{Minimum operating voltage of load}$$

- 2) If the internal resistance of a light emitting diode causes a problem, select a switch without an indicator light.

<Solid state switches>

- 3) Generally, the internal voltage drop will be greater with a 2-wire solid state auto switch than with a reed switch. Take the same precautions as in 1) above.

Also, note that a 12VDC relay is not applicable.

5. Monitor leakage current.

<Solid state switches>

With a 2-wire solid state auto switch, current (leakage current) flows to the load to operate the internal circuit even when in the off state.

$$\text{Current to operate load (off condition)} > \text{Leakage current}$$

If the condition given in the above formula is not met, it will not reset correctly (stays on). Use a 3-wire switch if this specification cannot be satisfied.

Moreover, leakage current flow to the load will be "n" times larger when "n" auto switches are connected in parallel.

6. Do not use a load that generates surge voltage.

<Reed switches>

If driving a load that generates surge voltage, such as a relay, use a switch with a built-in contact protection circuit or a contact protection box.

<Solid state switches>

Although a zener diode for surge protection is connected at the output side of a solid state auto switch, damage may still occur if a surge is applied repeatedly. When directly driving a load which generates surge, such as a relay or solenoid valve, use a type of switch with a built-in surge absorbing element.

7. Cautions for use in an interlock circuit

When an auto switch is used for an interlock signal requiring high reliability, devise a double interlock system to safeguard against malfunctions by providing a mechanical protection function, or by also using another switch (sensor) together with the auto switch.

Also, perform periodic inspection and confirm proper operation.

8. Ensure sufficient clearance for maintenance activities.

When designing an application, be sure to allow sufficient clearance for maintenance and inspections.



Series CRB2/CRBU2/CRB1

Auto Switch Precautions 2

Be sure to read before handling.

Mounting and Adjustment

Warning

1. Do not drop or bump.

Do not drop, bump, or apply excessive impacts (300m/s² or more for reed switches and 1000m/s² or more for solid state switches) while handling. Although the body of the switch may not be damaged, the inside of the switch could be damaged and cause a malfunction.

2. Do not carry a rotary actuator by the auto switch lead wires.

Never carry a actuator by its lead wires. This may not only cause broken lead wires, but it may cause internal elements of the switch to be damaged by the stress.

3. Mount switches using the proper tightening torque.

When a switch is tightened beyond the torque range, the mounting screws, mounting bracket or switch may be damaged. On the other hand, tightening below torque range may allow the switch to slip out of position.

4. Mount a switch at the center of the operating range.

Adjust the mounting position of an auto switch so that the piston stops at the center of the operating range (the range in which a switch is on). (The mounting positions shown in the catalog indicate the optimum position at the stroke end.) If mounted at the end of the operating range (around the borderline of on and off), the operation will be unstable.

Wiring

Warning

1. Avoid repeatedly bending or stretching lead wires.

Broken lead wires will result from repeatedly applying bending stress or stretching force to the lead wires.

2. Be sure to connect the load before power is applied.

<2-wire type>

If the power is turned on when an auto switch is not connected to a load, the switch will be instantly damaged because of excess current.

3. Confirm proper insulation of wiring.

Be certain that there is no faulty wiring insulation (such as contact with other circuits, ground fault, improper insulation between terminals). Damage may occur due to excess current flow into a switch.

4. Do not wire in conjunction with power lines or high voltage lines.

Wire separately from power lines or high voltage lines, avoiding parallel wiring or wiring in the same conduit with these lines. Control circuits containing auto switches may malfunction due to noise from these other lines.

Wiring

Warning

5. Do not allow short circuit of loads.

<Reed switches>

If the power is turned on with a load in a short circuited condition, the switch will be instantly damaged because of excess current flow into the switch.

<Solid state switches>

D-F9□(V), D-F9□W(V) and all models of PNP output type switches do not have built-in short circuit protection circuits. If loads are short circuited, the switches will be instantly damaged, as in the case of reed switches.

Take special care to avoid reverse wiring with the brown power supply line and the black output line on 3-wire type switches.

6. Avoid incorrect wiring.

<Reed switches>

A 24VDC switch with indicator light has polarity. The brown lead wire or terminal No. 1 is (+), and the blue lead wire or terminal No. 2 is (-).

1) If connections are reversed, the switch will still operate, but the light emitting diode will not light up.

Also note that a current greater than the maximum specified one will damage a light emitting diode and make it inoperable.

<Solid state switches>

1) Even if connections are reversed on a 2-wire type switch, the switch will not be damaged because it is protected by a protection circuit, but it will remain in a normally on state. But reverse wiring in a load short circuit condition should be avoided to protect the switch from being damaged.

2) Even if (+) and (-) power supply line connections are reversed on a 3-wire type switch, the switch will be protected by a protection circuit. However, if the (+) power supply line is connected to the blue wire and the (-) power supply line is connected to the black wire, the switch will be damaged.

* Lead wire colour changes

Lead wire colors of SMC switches have been changed in order to meet NECA Standard 0402 for production beginning September, 1996 and thereafter. Please refer to the tables provided. Special care should be taken regarding wire polarity during the time that the old colours still coexist with the new colours.

2-wire			3-wire		
	Old	New		Old	New
Output (+)	Red	Brown	Power supply (+)	Red	Brown
Output (-)	Black	Blue	GND	Black	Blue
			Output	White	Black



Series **CRB2/CRBU2/CRB1**

Auto Switch Precautions 3

Be sure to read before handling.

Operating Environment

Warning

1. Never use in an atmosphere of explosive gases.

The construction of auto switches is not intended to prevent explosion. Never use in an atmosphere with an explosive gas since this may cause a serious explosion.

2. Do not use in an area where a magnetic field is generated.

Auto switches will malfunction or magnets inside actuators will become demagnetized. (Consult with SMC regarding the availability of magnetic field resistant auto switches.)

3. Do not use in an environment where the auto switch will be continually exposed to water.

Switches satisfy IEC standard IP67 construction (JIS C 0920: watertight construction). Nevertheless, they should not be used in applications where they are continually exposed to water splash or spray. This may cause deterioration of the insulation or swelling of the potting resin inside switches and may cause a malfunction.

4. Do not use in an environment with oil or chemicals.

Consult with SMC if auto switches will be used in an environment laden with coolants, cleaning solvents, various oils or chemicals. If auto switches are used under these conditions for even a short time, they may be adversely affected by a deterioration of the insulation, a malfunction due to swelling of the potting resin, or hardening of the lead wires.

5. Do not use in an environment with temperature cycles.

Consult with SMC if switches are to be used where there are temperature cycles other than normal temperature changes, as they may be adversely affected internally.

6. Do not use in an environment where there is excessive impact shock.

<Reed switches>

When excessive impact (300m/s² or more) is applied to a reed switch during operation, the contact point may malfunction and generate or cut off a signal momentarily (1ms or less). Consult with SMC regarding the need to use a solid state switch depending on the environment.

7. Do not use in an area where surges are generated.

<Solid state switch>

When there are units (such as solenoid type lifters, high frequency induction furnaces, motors) that generate a large amount of surge in the area around actuators with solid state auto switches, their proximity or pressure may cause deterioration or damage to the internal circuit elements of the switches. Avoid sources of surge generation and crossed lines.

8. Avoid accumulation of iron waste or close contact with magnetic substances.

When a large accumulated amount of ferrous waste such as machining chips or welding spatter, or a magnetic substance (something attracted by a magnet) is brought into close proximity to an actuator with auto switches, this may cause the auto switches to malfunction due to a loss of the magnetic force inside the actuator.

Maintenance

Warning

1. Perform the following maintenance inspection and services periodically in order to prevent possible danger due to unexpected auto switch malfunction.

- 1) Securely tighten switch mounting screws.

If screws become loose or the mounting position is dislocated, retighten them after readjusting the mounting position.

- 2) Confirm that there is no damage to lead wires.

To prevent faulty insulation, replace switches or repair lead wires if damage is discovered.

Other

Warning

1. Consult with SMC concerning water resistance, elasticity of lead wires, and usage at welding sites.



Austria
SMC Pneumatik GmbH (Austria).
Girakstrasse 8, A-2100 Körneuburg
Phone: 02262-62280, Fax: 02262-62285



Germany
SMC Pneumatik GmbH
Boschring 13-15, D-63329 Egelsbach
Phone: 06103-4020, Fax: 06103-402139



Netherlands
SMC Pneumatics BV
Postbus 308, 1000 AH Amsterdam
Phone: 020-5318888, Fax: 020-5318880



Slovenia
SMC Slovenia d.o.o.
Grajski trg 15, 8360 Zuzemberk
Phone: 068-88 044 Fax: 068-88 041



Belgium
SMC Pneumatics N.V./S.A.
Nijverheidsstraat 20, B-2160 Wommelgem
Phone: 03-355-1464, Fax: 03-355-1466



Greece
S. Parianopoulos S.A.
9, Konstantinoupolos Street,
GR-11855 Athens
Phone: 01-3426076, Fax: 01-3455578



Norway
SMC Pneumatics Norway AS
Vollsveien 13 C, Granfoss Næringspark
N-1324 Lysaker
Tel: (47) 67 12 90 20, Fax: (47) 67 12 90 21



Spain
SMC España, S.A.
Zuazobidea 14, Pol. Ind. Jundiz,
E-01015 Vitoria
Phone: 945-184 100, Fax: 945-184 124



Czech
SMC Czech.s.r.o.
Kodanska 46, CZ-100 10 Prague 10
Phone: 02-67154 790, Fax: 02-67154 793



Hungary
SMC Hungary Kft.
Budafoki ut 107-113, 1117 Budapest
Phone: 01-204 4366, Fax: 01-204 4371



Poland
Semac Co., Ltd.
PL-05-075 Wesola k/Warszaway, ul. Wspolna 1A
Phone: 022-6131847, Fax: 022-613-3028



Sweden
SMC Pneumatics Sweden A.B.
Ekhagsvägen 29-31, S-14105 Huddinge
Phone: 08-603 07 00, Fax: 08-603 07 10



Denmark
SMC Pneumatik
Knudsminde 4B, DK-8300 Odder
Phone: (45)70252900, Fax: (45)70252901



Ireland
SMC Pneumatics (Ireland) Ltd.
2002 Citywest Business Campus,
Naas Road, Saggart, Co. Dublin
Phone: 01-403 9000, Fax: 01-464 0500



Portugal
SMC España (Sucursal Portugal), S.A.
Rua de Engº Ferreira Dias 452, 4100 Porto
Phone: 02-610-89-22, Fax: 02-610-89-36



Switzerland
SMC Pneumatik AG
Dorfstrasse 7, CH-8484 Weisslingen
Phone: 052-396-3131, Fax: 052-396-3191



Estonia
Teknoma Eesti AS
Mustamäe tee 5, EE-0006 Tallinn, Estonia
Phone: 259530, Fax: 259531



Italy
SMC Italia S.p.A
Via Garibaldi 62, I-20061 Carugate, (Milano)
Phone: 02-92711, Fax: 02-92150394



Romania
SMC Romania srl
Vasile Stroescu 19, Sector 2, Bucharest
Phone: 01-210-1354, Fax: 01-210-1680



Turkey
Entek Pnömatik San. ve Tic Ltd. Sti.
Perpa Tic. Merkezi Kat: 11 No: 1625,
TR-80270 Okmeydanı Istanbul
Phone: 0212-221-1512, Fax: 0212-220-2381



Finland
SMC Pneumatikka OY
Veneentekijäntie 7, SF-00210 Helsinki
Phone: 09-681021, Fax: 09-6810233



Latvia
Ottensten Latvia SIA
Ciekurkalna Prima Gara Linija 11,
LV-1026 Riga, Latvia
Phone: 371-23-68625, Fax: 371-75-56748



Russia
SMC Pneumatik LLC.
36/40 Sredny pr. St. Petersburg 199004
Phone: (812) 118 5445, Fax: (812) 118 5449



UK
SMC Pneumatics (UK) Ltd
Vincent Avenue, Crownhill,
Milton Keynes, MK8 0AN
Phone: 01908-563888 Fax: 01908-561185



France
SMC Pneumatique, S.A.
1, Boulevard de Strasbourg, Parc Gustave Eiffel
Bussy Saint Georges
F-77607 Marne La Vallée Cedex 3
Phone: 01-6476 1000, Fax: 01-6476 1010



Lithuania
UAB Ottensten Lietuva
Savanoriu pr.180, LT-2600 Vilnius, Lithuania
Phone/Fax: 370-2651602



Slovakia
SMC Slovakia s.r.o.
Pribinova ul. C. 25, 819 02 Bratislava
Phone: 0-563 3548, Fax: 07-563 3551

OTHER SUBSIDIARIES WORLDWIDE:

ARGENTINA, AUSTRALIA, BOLIVIA, BRASIL, CANADA, CHILE, CHINA, HONG KONG, INDIA, MALAYSIA, MEXICO, NEW ZEALAND, PHILIPPINES, SINGAPORE, SOUTH KOREA, TAIWAN, THAILAND, USA, VENEZUELA

SMC UK Contact Numbers

Head Office: SMC Pneumatics (UK) Ltd, Vincent Avenue, Crownhill, Milton Keynes MK8 0AN

THE NATIONAL SALES CENTRE FOR ENGLAND & WALES

Internal Sales

(Price, Delivery Information & Order Placement)

Freephone: 0800 138 2930 Fax: 01908 555064
e-mail: sales@smcpneumatics.co.uk

Customer Services

(Post-Order Resolution)

Freephone: 0800 138 2931 Fax: 01908 555065
e-mail: customerservice@smcpneumatics.co.uk

TECHNICAL CENTRE

Freephone: 0800 138 2932 Fax: 01908 555066
e-mail: technical@smcpneumatics.co.uk

SMC FAST RESPONSE

(Literature & Catalogue Requests)

0800 0262006

SMC SALES CENTRE FOR SCOTLAND & N. IRELAND

Tel: 01236 781133 Fax: 01236 780611

SMC Pneumatics (UK) Ltd, 1 Carradale Crescent, Broadwood Business Park, Cumbernauld, Glasgow G69 9LE

SMC UK Sales Partners

Birmingham
JAMES LISTER
Tel: 0121 5803800
Fax: 0121 5535951

Bristol
APPLIED AUTOMATION
Tel: 0117 9827769
Fax: 0117 9235522

Cardiff
WALES FLUID POWER
Tel: 02920 494551
Fax: 02920 481955

Blackburn
BEST PNEUMATIC SYSTEMS LTD
Tel: 01254 395000
Fax: 01254 390555

Bury St Edmunds
PNEUMATIC LINES
Tel: 01284 706239
Fax: 01284 761218

Plymouth
APPLIED AUTOMATION
Tel: 01752 343300
Fax: 01752 341161