

G512B-2\$;G512G-2\$

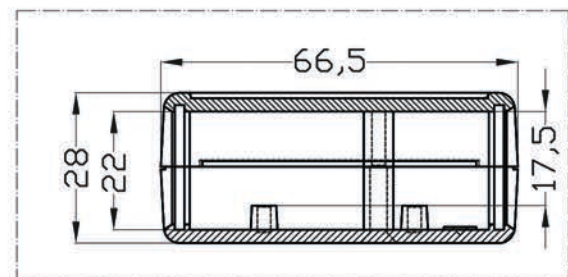
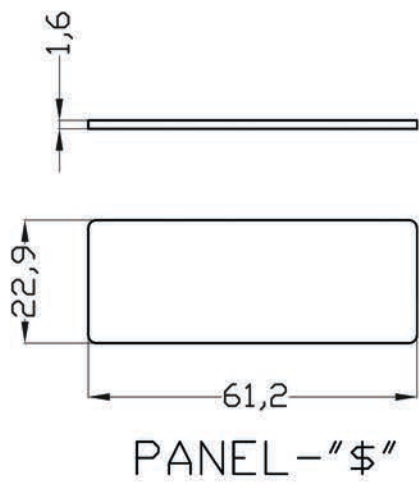
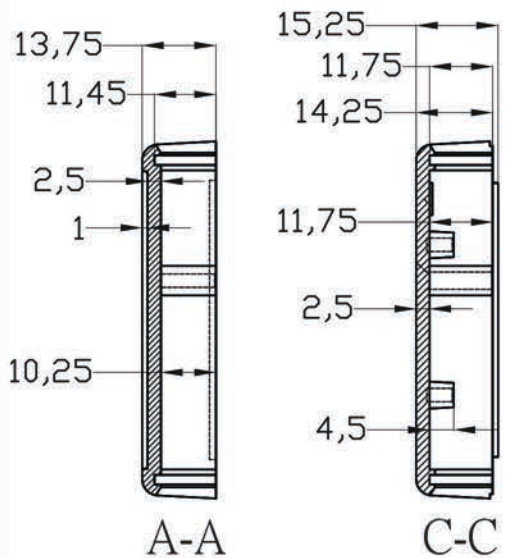
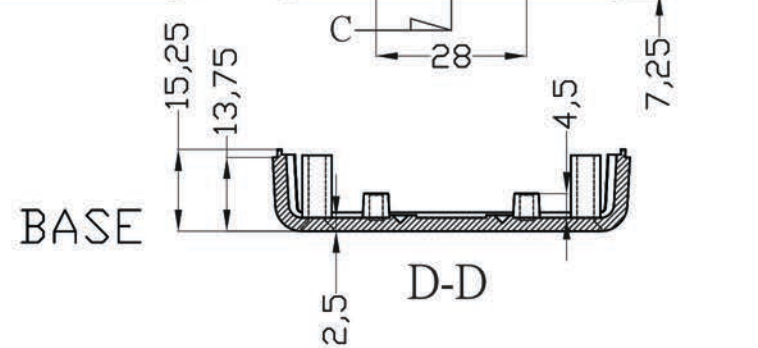
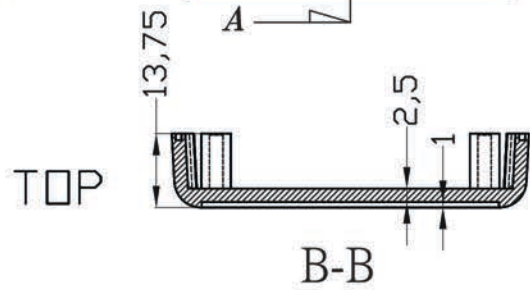
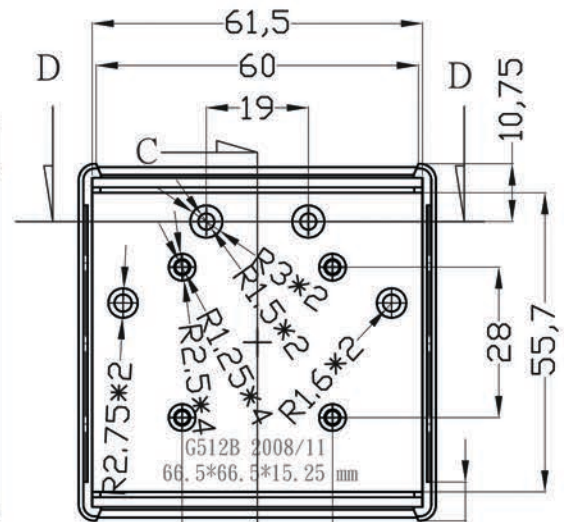
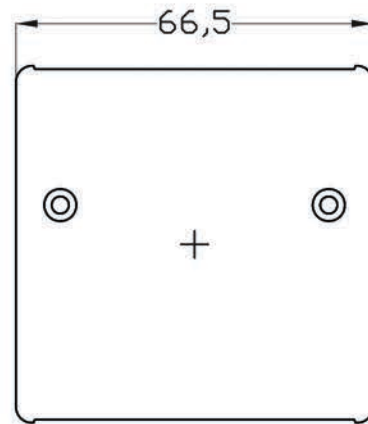
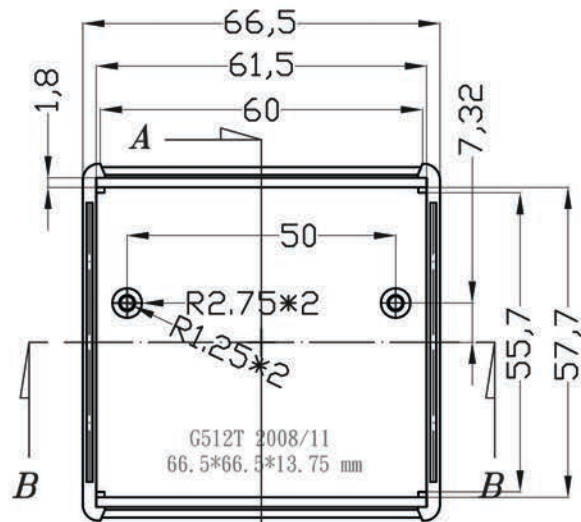
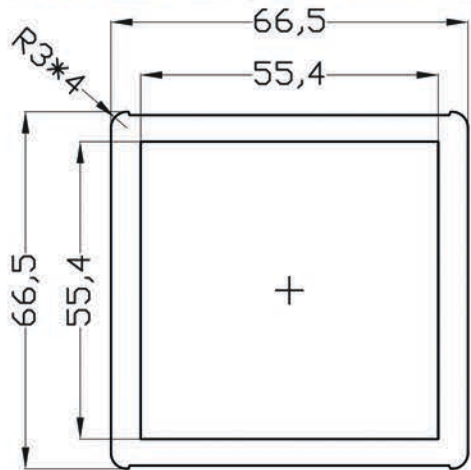

According to ISO 2768-m

Measuring DIM.=L	Tolerance
0.5<L≤3.0 mm	±0.1 mm
3.0<L≤6.0 mm	±0.1 mm
6.0<L≤30.0 mm	±0.2 mm
30.0<L≤120.0 mm	±0.3 mm
120.0<L≤400.0 mm	±0.5 mm
400.0<L≤1000.0 mm	±0.8 mm

ITEM NO	DESCRIPTION
G512B-2\$	BLACK(G512T+G512B)*1+BLACK(PANEL-"\$")*2+M3*21 mm BLACK SCREWS *2
G512G-2\$	GRAY(G512T+G512B)*1+GRAY(PANEL-"\$")*2+M3*21 mm BLACK SCREWS *2

宜又實業有限公司
GAINTA INDUSTRIES LTD.

設計 DES'D BY	繪圖 DRA'D BY	核圖 CHK'D BY	比例 SCALE	日期 DATE	材質 MATE.	圖名 TITLE	圖號 DWG NO.	圖號 REVISID	說明 DESCRIPTION
	JACKY			2009/1/7	ABS	G512B-2\$;G512G-2\$		A	