

# ATOF® Blade Fuses

Rated 32V

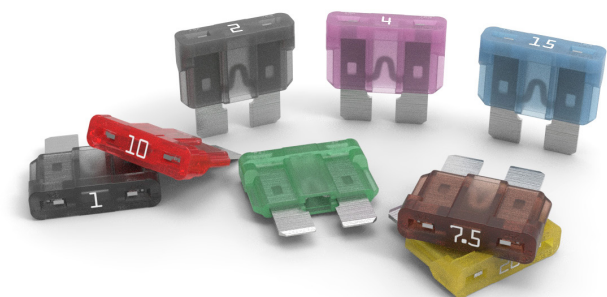

ATOF® Shunt

## Specifications

<b>Voltage Rating:</b>	32 V dc
<b>Interrupting Rating:</b>	1000 A @ 32 V dc
<b>Recommended Environmental Temperature:</b>	-40 °C to +125 °C (ATOF®) -40 °C to +105 °C (ATOF® Shunt)
<b>Terminals Material:</b>	Tin- or silver-plated*
<b>Housing Material:</b>	PA66 (UL 94 Flammability rating of V-2)
<b>Net Weight Per Fuse:</b>	1.4 g ± 5 %
<b>Comply With:</b>	SAE J1284 and ISO 8820-3
<b>UL Listed:</b>	File AU1410
<b>CSA Certified:</b>	File No. 29862

\*Tin plating's temperature limit is =130 °C. Silver plating allows up to 150 °C at the terminal interface.

## Description

ATOF® automotive blade fuses were developed to take the place of obsolete ATO Series 257 fuses. Automakers consider ATOF fuses standard equipment for protecting low-voltage circuits.

## Applications

- Cars
- Trucks
- SUVs
- Offroad vehicles
- Buses
- Watercraft as approved by Littelfuse®

## Features & Benefits

- Color coding indicates amperage rating
- See-through housings make it easier to see when fuses blow
- Checkpoints on top make it possible to measure resistance without removing the fuse
- High-contrast ampere stamps on housings aid identification
- Simple to install and remove
- Shunt version available (Tin plated only)

## Ordering Information

Part Number	Current Rating (A)	Package Size
ATOF® (Tin Plated)		
0287xxx.PXCN	1-40 & Shunt	2000
0287xxx.U	1-40	500
0287xxx.H	1-40	100
0287xxx.L	1-40	50
ATO Ag (Silver-Plated)		
0287xxx.PXS	1-40	2000

# ATOF® Blade Fuses

Rated 32V

## Ratings

Part Number	Current Rating (A)	Housing Material Color	Test Cable Size (mm <sup>2</sup> )	Typ. Voltage Drop (mV)	Typ. Cold Resistance (mΩ)	Typ. I <sup>2</sup> t (A <sup>2</sup> s)
0287001._	1	Black	0.35	176	123	0.4
0287002._	2	Grey	0.35	141	53.5	1.4
0287003._	3	Purple	0.35	137	31.1	7.4
0287004._	4	Pink	0.35	136	22.8	14
0287005._	5	Brown	0.5	128	17.85	26
028707.5._	7.5	Dark Brown	0.75	116	10.91	60
0287010._	10	Red	1	109	7.70	115
0287015._	15	Blue	1.5	102	4.80	340
0287020._	20	Yellow	2.5	98	3.38	520
0287025._	25	Light Orange	2.5	92	2.52	1 000
0287030._	30	Green	4	84	1.97	1 500
0287035._	35	Dark Green	6	87	1.61	2 300
0287040._	40	Orange	6	96	1.44	3 300
0287900._	SHUNT	White	-	-	-	-

The typical I<sup>2</sup>t is an average value calculated from the breaking capacity tests by using the melting time before the arcing occurs.

## Dimensions

Dimensions in mm for reference only.  
See outline drawing for dimensions and tolerances.

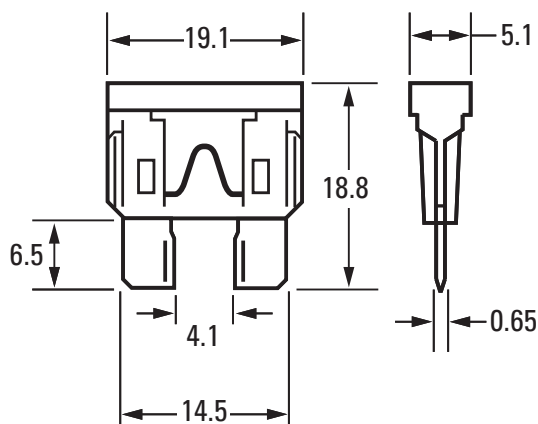

# ATOF® Blade Fuses

## Rated 32V

### Time-Current Characteristic Curves

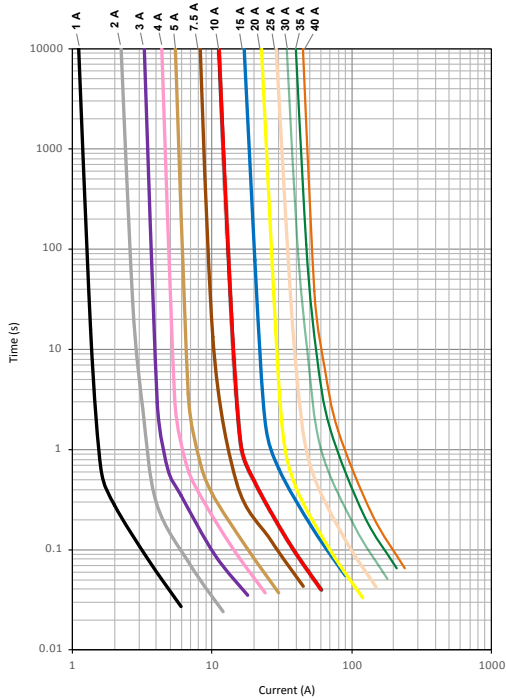

### Time-Current Characteristics

% of Rating	Current Rating (A)	Opening Time Min. / Max. (s)
100	35-40	360,000 / ∞
110	1-30	360,000 / ∞
135	1-2	0.35 / 600
	3-40	0.750 / 600
160	1-40	0.250 / 50
	3-40	0.15 / 5
200	1-2	0.1 / 5
	3-40	0.08 / 0.5
350	1-2	0.02 / 0.5
	3-40	0.1 max
600	1-30	0.15 max
	35-40	0.15 max

### Typical Derating of Fuse Melting Element

Temperature security margin is 20 %.  
 Wire cross-section and fixture test setup refer to ISO 8820-3.  
 Please contact Littelfuse for details regarding derating test setup.

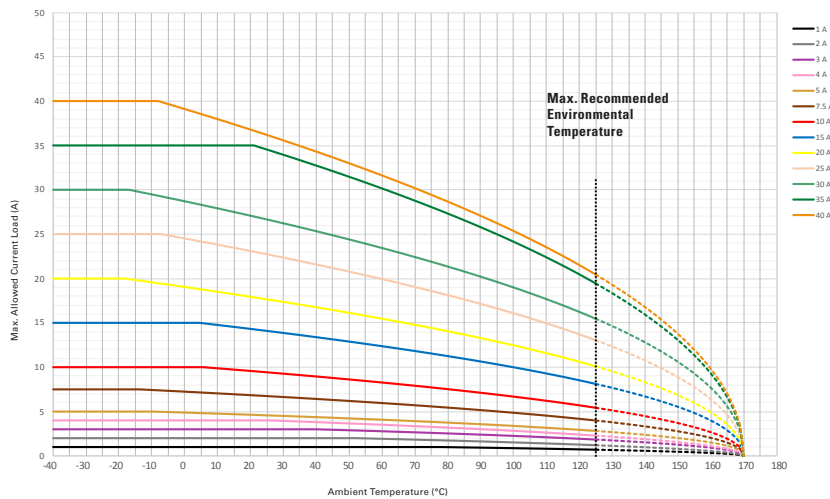

### Temperature Table

	Max. allowed current load (A) at ambient temperature (typical derating)						
	-40 °C	0 °C	20 °C	65 °C	85 °C	110 °C	125 °C
<b>1 A</b>	1	1	1	1	1	1	1
<b>2 A</b>	2	2	2	2	2	1	1
<b>3 A</b>	3	3	3	3	2	2	2
<b>4 A</b>	4	4	4	3	3	3	2
<b>5 A</b>	5	5	5	4	4	3	3
<b>7.5 A</b>	8	7	7	6	5	5	4
<b>10 A</b>	10	10	10	8	7	6	5
<b>15 A</b>	15	15	14	12	11	9	8
<b>20 A</b>	20	19	18	15	14	12	10
<b>25 A</b>	25	25	23	19	18	15	13
<b>30 A</b>	30	29	27	23	21	18	15
<b>35 A</b>	35	35	35	29	27	22	19
<b>40 A</b>	40	39	37	31	28	24	20

ATOF® SHUNT Maximum Continuous Load at 85°C: 40A

Derating curves may change depending on the final condition of the application (terminals' characteristics, wire size, etc.). Please ask Littelfuse® for more information.