

0-1564562-1 AS SHOWN  
 0-1564562-1 wie gezeigt

PROJEKT NR. SEE NOTE 9		REVISIONS			
P	LTR	DESCRIPTION	DATE	DWN	APVD
	K	DETAILS SEE PCN E-15-008283	01JUN2015	Ho.	Gilch
	K1	DETAILS SEE PCN E-16-013669	26SEP2016	MAH.	GILC
	L	DETAILS SEE PCN E-19-000765	20MAY2019	MAH.	GILC
	L1	DETAILS SEE PCN E-19-015134	15OCT2019	MAH.	GILC

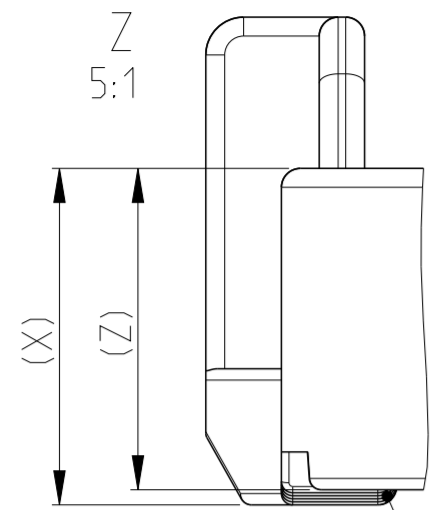

GEOMETRY GRADUALLY INCREASING FROM DIMENSION "Z" TO "X".  
 Geometrie stufenweise ansteigend von Dimension "Z" nach "X".

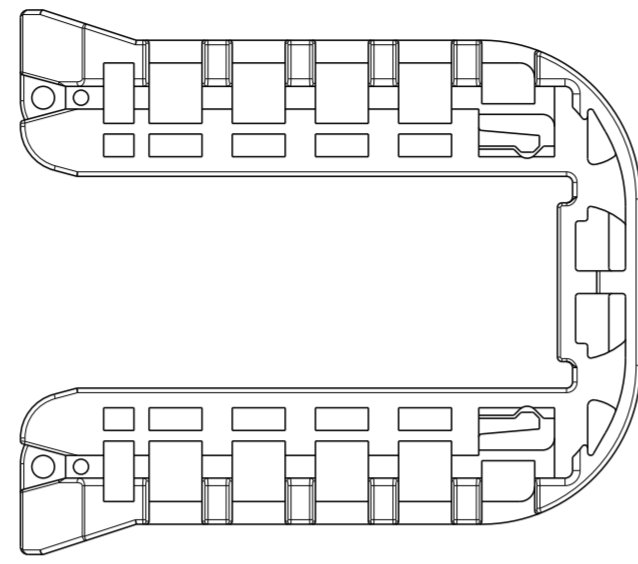

NOTES  
 Bemerkungen

- 1 TE ORDER-NO.  
TE Bestell-Nr.
- 2 PRODUCTION DATE  
Produktionsdatum
- 3 LETTER-INSERT FOR THE REVISION STATUS OF THE MOULD  
Schriftsatz fuer Aenderungszustand des Werkzeuges
- 4 MATERIAL MARKING ACCORDING TO VDA 260  
Werkstoffkennzeichnung nach VDA 260
- 5 BULK PACKAGING IN CORRUGATED BOX  
Schuettgut im Versandkarton
- 6 MOULD CAVITY MARKING  
Nestmarkierung
- 7 TE LOGO  
TE Logo
- 8 WARPAGE PERMITTED UP TO -1.5mm FROM NOMINAL SIZE  
Verzug zuLaessig bis -1.5mm vom Nennmass
- 9 SUITABLE FOR TAB HOUSING WITH FLANGE GROUP D  
SEE PRODUCT GROUP DRAWING 1563709  
Passend zu Flachsteckergehaeusen mit Flansch der Gruppe D  
siehe Produktgruppenzeichnung 1563709
- 10 MARKING FOR SUITABLE SHEET METAL THICKNESS (NOMINAL SIZE)  
Kennzeichnung fuer passende Blechstaeerke (Nennmass)

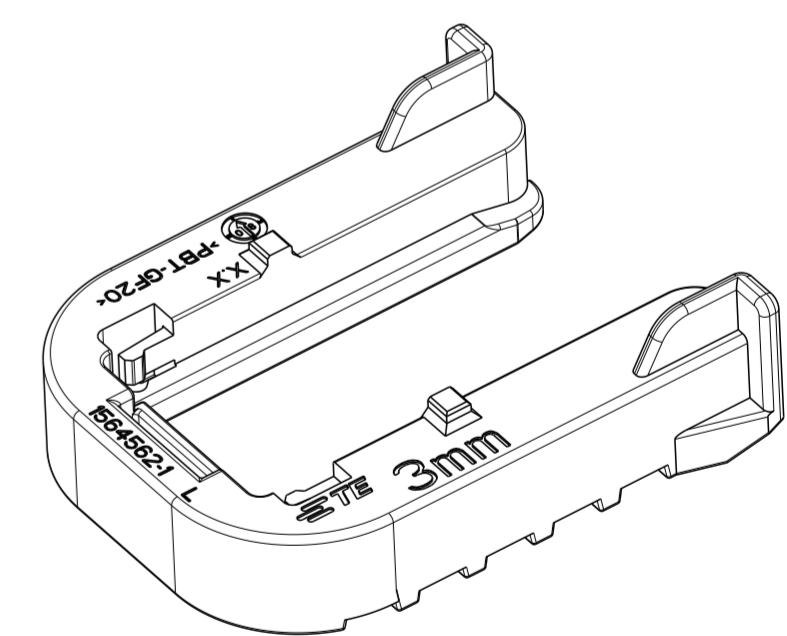
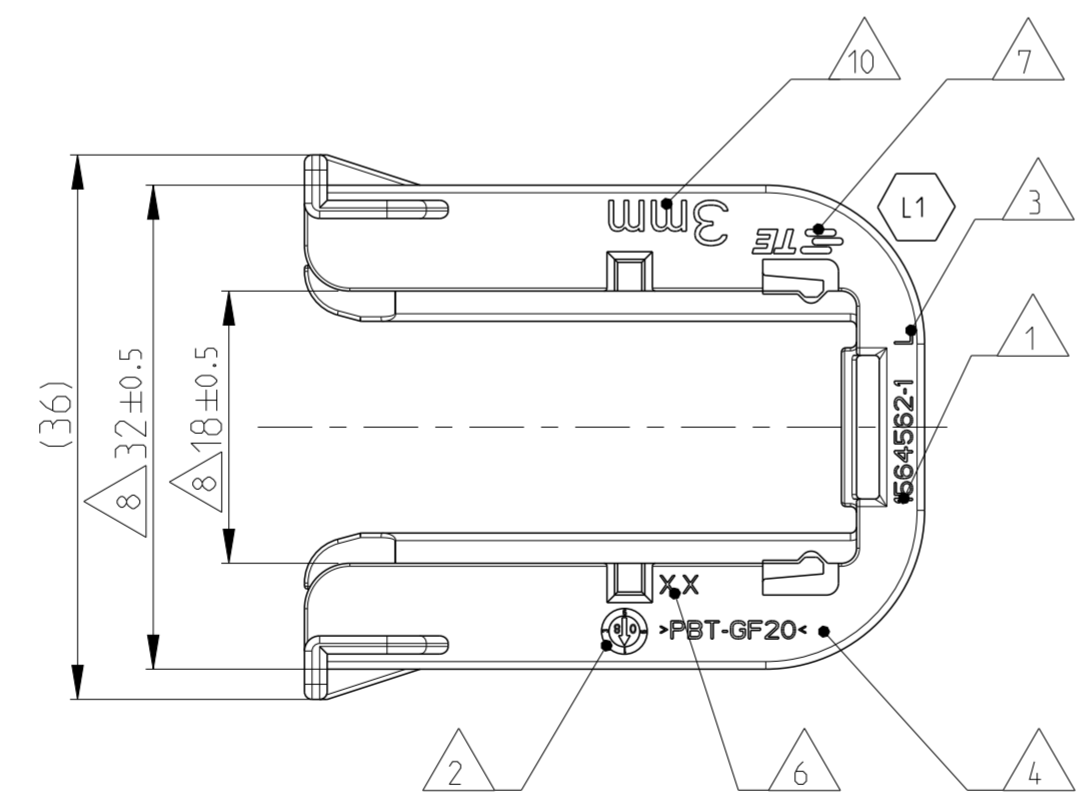
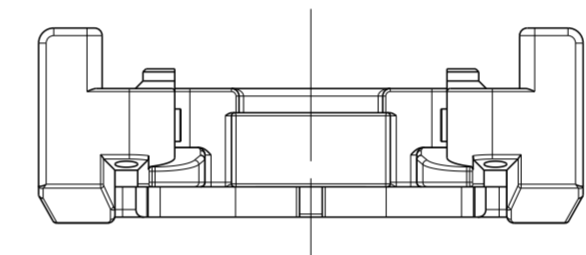
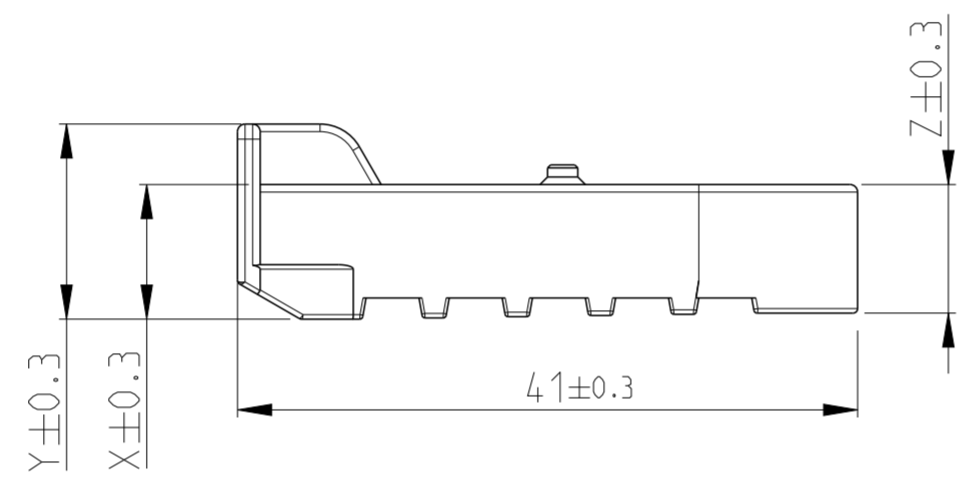
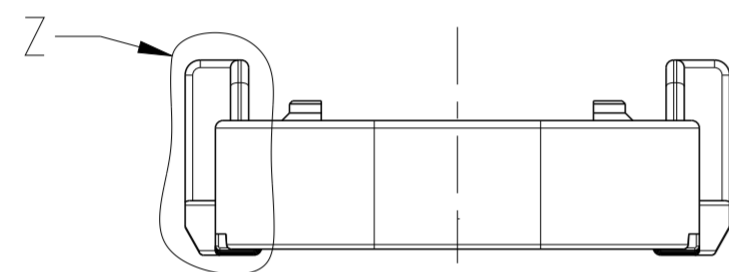

TE ORDER-NO. TE Bestell-Nr.	REV.	SHEET METAL THICKNESS Blechdicke	DIM X	DIM Y	DIM Z	MATERIAL	COLOUR Farbe	WEIGHT (g)	DESCRIPTION Beschreibung	ITEM
0-1564562-6	L	3.5±0.1mm	8.4	12.4	8.0	PBT-GF20/V-0	GREY grau	5.5	Slide, FOR 3.5mm SHEET METAL Schieber, fuer Blech 3.5mm Dicke	6
0-1564562-5	L	1.5±0.1mm	10.4	14.4	10.0	PBT-GF20/V-0	GREY grau	6.2	Slide, FOR 1.5mm SHEET METAL Schieber, fuer Blech 1.5mm Dicke	5
0-1564562-4	L	1.0±0.1mm	10.9	14.9	10.5	PBT-GF20/V-0	NATURAL natur	6.4	Slide, FOR 1.0mm SHEET METAL Schieber, fuer Blech 1.0mm Dicke	4
-	-	4.0±0.1mm	-	-	-	PBT-GF20/V-0	-	-	Slide, FOR 4.0mm SHEET METAL Schieber, fuer Blech 4.0mm Dicke	3
0-1564562-2	L	2.5±0.1mm	9.4	13.4	9.0	PBT-GF20/V-0	RED red	5.7	Slide, FOR 2.5mm SHEET METAL Schieber, fuer Blech 2.5mm Dicke	2
0-1564562-1	L	3.0±0.1mm	8.9	12.9	8.5	PBT-GF20/V-0	YELLOW gelb	5.6	Slide, FOR 3mm SHEET METAL Schieber, fuer Blech 3mm Dicke	1

THIS DRAWING IS A CONTROLLED DOCUMENT.  
 DIESES ZEICHNUNGSDOKUMENT WIRD DURCH AMV INTEGRIERT KONTROLLIERT.  
 AENDERUNGEN, DIE DEM TECHNISCHEN FORTSCHRITT DIENEN, SIND VORBEHALTEN.  
 DEN JEWEILS LETZTIGELIAGEN AENDERUNGSSTAND ERFAEHREN SIE AUF ANFRAGE.

DIMENSIONS: mm

TOLERANCES UNLESS OTHERWISE SPECIFIED:  
 ACC. TO DIN 16901-140  
 0. PLC ±  
 1. PLC ±  
 2. PLC ± ISO 8015  
 3. PLC ±  
 4. PLC ±  
 ANGLES ±2°  
 FINISH

MATERIAL SEE TABLE

DWN Shilpa Bhavikatti 20FEB2009  
 CHK J. Granzow 21FEB2009  
 APVD C. Eberwein 21FEB2009

TE Connectivity

NAME SLIDE, TAB HOUSING  
 Schieber, Flachsteckergehaeuse  
 HDSCS - GROUP D

PRODUCT SPEC 108-94020  
 APPLICATION SPEC 114-18756

SIZE A2 CAGE CODE 00779 DRAWING NO. 0-1564562 RESTRICTED TO

WEIGHT SEE TABLE SCALE 2:1 SHEET 1 OF 1 REV L1

CUSTOMER DRAWING

# Mouser Electronics

Authorized Distributor

Click to View Pricing, Inventory, Delivery & Lifecycle Information:

[TE Connectivity:](#)

[1564562-2](#)