

REVISIONS			
REV	DESCRIPTION	DATE	APPROVED
-	INITIAL RELEASE	02/02/05	A.D.M.

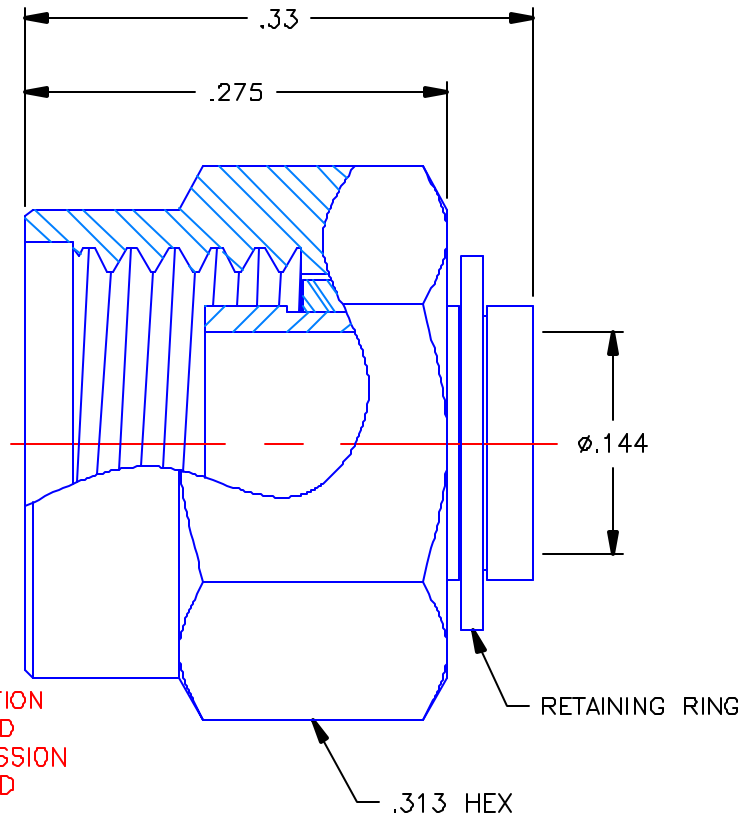

PROPRIETARY INFORMATION
NOT TO BE RELEASED
WITHOUT WRITTEN PERMISSION
FROM AN AUTHORIZED
REPRESENTATIVE OF
APPLIED ENGINEERING PRODUCTS

NOTES: CONFORMS TO MIL-C-39012 SMA SERIES

MATERIALS:

1. BODY & COUPLING NUT = STAINLESS STEEL PER ASTM A582, ALLOY 303, CONDITION "A".
2. RETAINING RING = BERYLLIUM COPPER PER ASTM B196, ALLOY C17300, TEMPER TD04.
3. GASKET = SILICONE RUBBER PER ZZ-R-765, CLASS 2B, GRADE 65-75.

FINISHES:

1. COUPLING NUT = PASSIVATE QQ-P-35, TYPE VI.
2. ALL OTHER METAL PARTS = NICKEL PLATE PER QQ-N-290, CLASS 1, GRADE G, EXCEPT .0001 TO .0002 THICK OVER .00005 TO .00010 THICK COPPER PER MIL-C-14550.

UNLESS OTHERWISE SPECIFIED DIMENSIONS ARE IN INCHES TOLERANCES ON	DWN. A.D.M.	DATE 01/31/05	 APPLIED ENGINEERING PRODUCTS 104 John W. Murphy Dr. New Haven, CT 06513
	CHKD: G.L.	DATE 02/02/05	
DECIMAL	ANGLE	APVD: D.J.C.	DATE 02/02/05
REFERENCE:		MATERIALS & FINISHES: SEE NOTES	
ORIGINATOR: A.D.M. DATE: 01/31/05		SIZE A	FSCM NO. 19505
		DWG NO. 9301-7063-009	REV -
		SCALE 8:1	SHEET 1 OF 1

9301-7063-009

Mouser Electronics

Authorized Distributor

Click to View Pricing, Inventory, Delivery & Lifecycle Information:

Radial:

[9301-7063-009](tel:9301-7063-009)