

High-current feed-through terminal blocks

Notes on the installation of high-current feed-through terminal blocks from Phoenix Contact

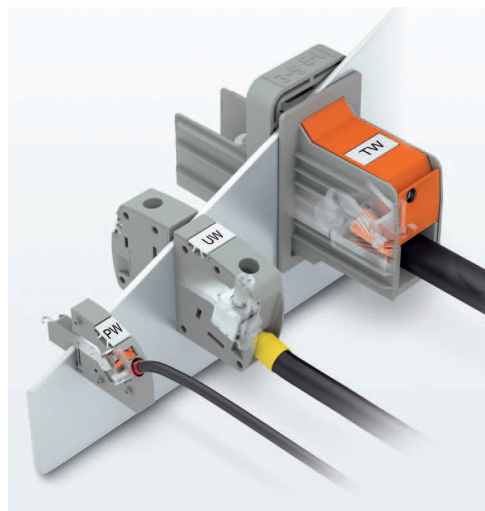

Application note
109248_en_03

© PHOENIX CONTACT 2021-10-06

1 Description

This document provides an overview of the installation of high-current feed-through terminal blocks from Phoenix Contact.

Different series of high-current feed-through terminal blocks exist. This application note applies to the following series:

- DFK...
- HDFK...
- PLW...
- PW...
- PWO...
- UW...
- TW...
- VDFK...

It describes how to connect copper wires. For the connection of aluminum conductors, specific requirements must be observed (see [“How to use aluminum conductors” on page 12](#)).

Please also observe the notes printed on the product and the instructions supplied.

Table of contents

1	Description	1
2	Safety notes.....	2
2.1	Requirements on personnel.....	2
2.2	Installation notes.....	2
2.3	Installation notes.....	2
3	How to mount high-current feed-through terminal blocks	3
3.1	Mounting the UW, PW, or PWO series	3
3.2	Mounting the DFK, HDFK, or VDFK series	4
3.3	Mounting the TW series.....	5
3.4	Mounting the PLW series.....	5
4	How to install high-current feed-through terminal blocks	6
4.1	Screw connection	6
4.2	Push-in connection	7
4.3	Push-Lock connection	8
4.4	T-LOX knee-lever connection	9
4.5	Bolt connection.....	10
4.6	Soldering or spade connection	11
5	How to use aluminum conductors.....	12
5.1	Suitable panel feed-through terminals	12
5.2	Connecting aluminum conductors	12



Make sure you always use the latest documentation.
It can be downloaded at phoenixcontact.net/products.

2 Safety notes

2.1 Requirements on personnel

Only electrically qualified personnel may install and operate high-current feed-through terminal blocks.

The qualified personnel must be familiar with the basics of electrical engineering. They must be able to recognize and prevent danger.



This symbol on the packaging indicates that only personnel familiar with electrical engineering is allowed to install and operate terminal blocks.

2.2 Installation notes

- Mount the high-current feed-through terminal blocks to a housing panel.
- Observe the specifications for panel thickness.
- Install the terminal blocks in suitable housings. Observe the specifications for touch protection.
- The cable entry funnel is not touch-proof. Never connect or disconnect the terminals when a voltage is applied. To ensure touch protection, take appropriate measures.

2.3 Installation notes

Only use accessories and tools recommended by Phoenix Contact.

Observe the corresponding technical data.

You will find information:

- On the product
- On the packing label
- In the supplied documentation
- On the web at phoenixcontact.net/products under the product
- In the brochures or in the electronic catalog
- For packing slips, go to the download area of the product at phoenixcontact.net/products

Defective high-current feed-through terminal blocks

- Only put into use high-current feed-through terminal blocks that are free of faults.
- Immediately take defective terminal blocks out of service.
- Replace damaged high-current feed-through terminal blocks. Repairs are not possible.

3 How to mount high-current feed-through terminal blocks

3.1 Mounting the UW, PW, or PWO series

Figure 1 Latching the terminals (terminals shown are examples)

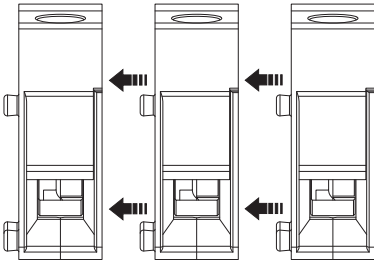

- Terminals designated with .../S can be snapped together with each other (or with terminals without .../S) to form terminal blocks.

Figure 2 Flange plates (terminals shown are examples)

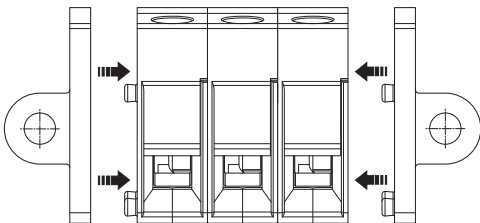

- To mount the terminals on the housing panel, you can snap flange plates onto each side of the terminal block. You can fasten a maximum of six connected terminals using the flange plates.

Figure 3 Spacer plates (terminals shown are examples)

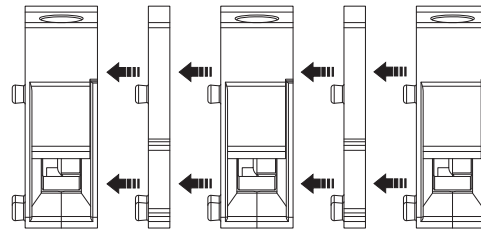

- You can snap in spacer plates between the terminals. The spacer plates increase air clearances and creepage distances between the poles.
- Create a panel cutout according to the drilling diagram.

Figure 4 Securing the terminal to prevent it from rotating (example shows an UW terminal)

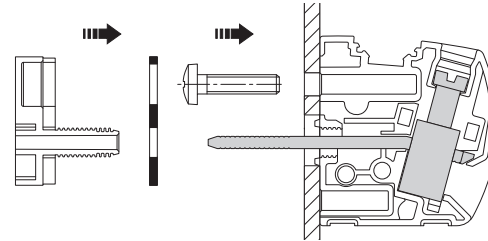

- You can use the included screws to additionally secure the terminal and prevent it from rotating. Only use screws with the dimensions specified below, else the electrical connection is at risk or a short circuit can be triggered.

	Screws
UW...4.../PW 4.../PWO 4	3x10 mm
UW...10...	4x11 mm
UW...16...	4x11 mm
UW...25...	5x14 mm
UW 50.../UW 95.../PWO 16	4x11 mm

- Join the outer and inner part of the terminal.
- Connect the cables. When doing so, observe the following instructions about each connection technology.
- Molded terminal blocks have an order designation including -POT. Fill those terminals with a suitable potting compound to ensure compliance with the voltage specifications.

3.2 Mounting the DFK, HDFK, or VDFK series

Figure 5 Latching the terminals (terminals shown are examples)

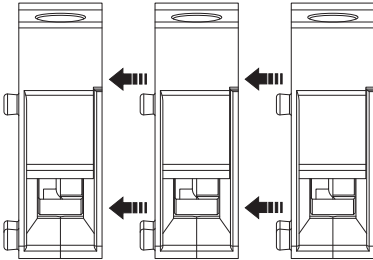

- Terminals designated with .../Z can be snapped together with each other (or with terminals without .../Z) to form terminal blocks.

Figure 6 Spacer plates (terminals shown are examples)

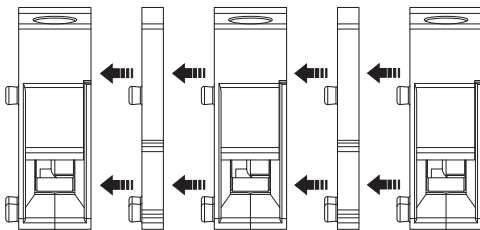

- You can snap in spacer plates between the terminals. The spacer plates increase air clearances and creepage distances between the poles.
- Create a panel cutout according to the drilling diagram.
- Join the outer and inner part of the terminal.
- Connect the cables. When doing so, observe the following instructions about each connection technology.
- Molded terminal blocks have an order designation including -VP. Fill those terminals with a suitable potting compound to ensure compliance with the voltage specifications.

Mounting the DFK and HDFK series PE panel feed-through terminal blocks

- Create a panel cutout according to the drilling diagram.
- The housing panel must be conductive. If necessary, remove coating from the connection point.
- **HDFK 25-PE**
Screw the external part to the panel. Tighten the screw with 1.8 Nm.
Push on the inner part.
- **DFK 4-PE**

Figure 7 Mounting the DFK 4-PE

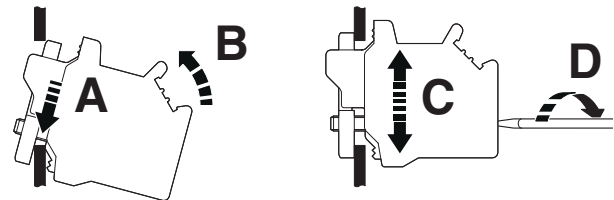

- Place the lower metal part of the terminal block behind the panel.
- Tilt the terminal block upwards until the entire metal part is located behind the panel.
- Push the terminal block into the correct position.
- Tighten the lower screw with 0.6 ... 0.8 Nm.

3.3 Mounting the TW series

TW terminals are secured in the housing by a mounting wedge.

Figure 8 Orientation in which to place the wedge

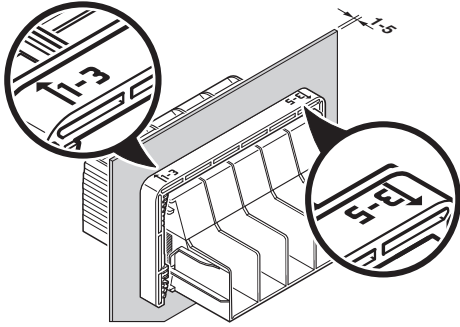

- The terminal block is secured in the housing by a mounting wedge. The wedge has two different sides to adapt to the thickness of the panel (1 to 3 mm and 3 to 5 mm). An arrow on the wedge indicates the orientation in which it should be attached.
- Create a panel cutout.
- Insert the terminal from the outside through the panel cutout.

Figure 9 Placing the wedge

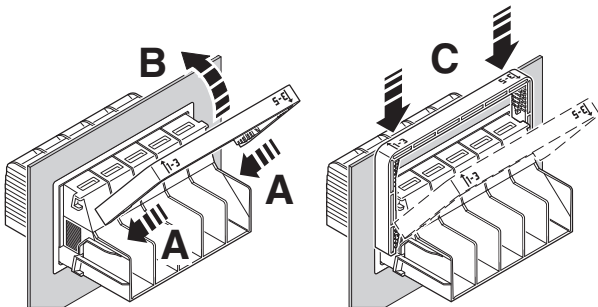

- Place the wedge from above, at an angle. Swivel it in the direction of the panel.
- Next, push the wedge down straight until it cannot be pushed any further.

3.4 Mounting the PLW series

- Create a panel cutout.
- Insert the terminal from the outside through the panel cutout.

If you screw on the terminal from the outside, then you need neither a spacer adapter nor a terminal wedge.

Figure 10 Placing the spacer adapter (DP) and the terminal wedge

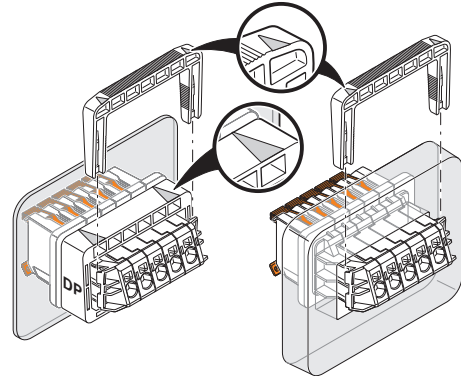

- You need a spacer adapter with a number of positions that matches the panel thickness. Push the spacer adapter over the inner part of the terminal block so that the arrows point to the panel. The spacer adapter has to be flush against the panel.
- Place the terminal wedge on the inner side of the housing from the top onto the terminal block so that the arrows point to the panel. Once the terminal wedge can be pushed no further, the terminal block is locked in securely.

4 How to install high-current feed-through terminal blocks

4.1 Screw connection

Series

DFK... UW...
 HDFK...
 VDFK...

Example

Figure 11 Screw connection with tension sleeve



The screw connection technology can be used to connect conductors with or without ferrules. It enables high contact forces per contact surface to be achieved irrespective of the conductor cross section.

Connecting the conductor

- Strip the specified length off the conductors.
- Flexible conductors can be fitted with ferrules.
Crimp the ferrules using crimping pliers. Ensure that the test requirements in accordance with DIN 46228-1 and DIN 46228-4 are met.
The length of the ferrule corresponds to the stripping length of the conductor.
- Insert the conductors into the terminal points. When connecting the conductors, make sure that they are inserted into the terminal point as far as they will go.

Figure 12 Connecting a conductor to an HDFK terminal

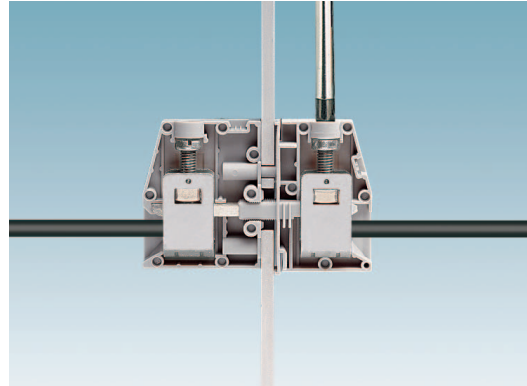

- Tighten the screws of all terminal points. Observe the specified torque.
- If you want to connect more than one conductor per terminal point, check the specifications regarding the connection capacity. The specifications apply to the connection of two conductors of the same cross section and the same conductor type.
- Loosen the terminal screw to open the terminal point and remove the conductor.

4.2 Push-in connection

Series

PW...
PWO...

Example

Figure 13 Push-in connection

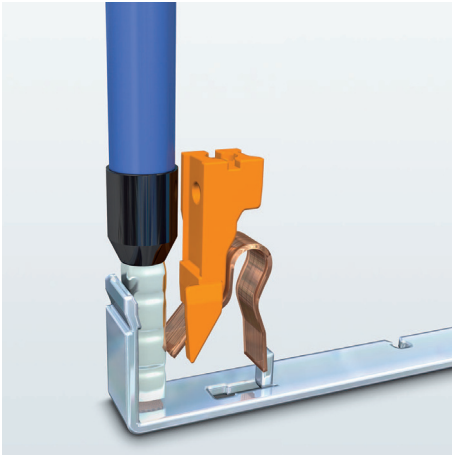

The Push-in connection technology (direct connection technology) enables tool-free wiring of conductors with ferrules or solid conductors. Conductors are directly connected without additional tools.

Connecting the conductor

We recommend protecting the terminal block from mechanical stress.

- Strip the specified length off the conductors.
- Flexible conductors can be fitted with ferrules. Crimp the ferrules using crimping pliers. Ensure that the test requirements in accordance with DIN 46228-1 and DIN 46228-4 are met. The length of the ferrule corresponds to the stripping length of the conductor.
- Rigid conductors and flexible conductors with ferrules can be inserted directly into the round opening of the terminal block without using tools.
- For small conductor cross sections and flexible conductors without ferrules, you first have to open the terminal point.

Series with push button

Push the push button down using a bladed screwdriver.

Series without push button

Insert a screwdriver into the slot above the connection.

Series with push button

Figure 14 Inserting and releasing the conductor

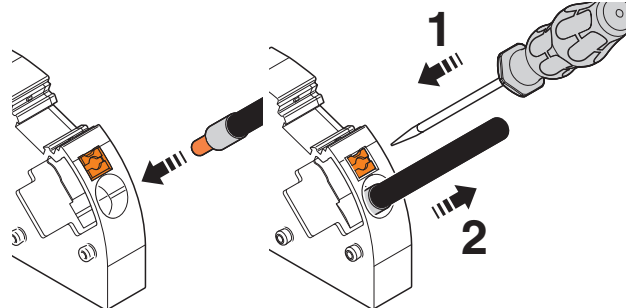

- For small conductor cross sections and flexible conductors without ferrules, you first have to open the terminal point.
- To release the conductor, push the push button down using a bladed screwdriver.

Series without push button

Figure 15 Inserting and releasing the conductor

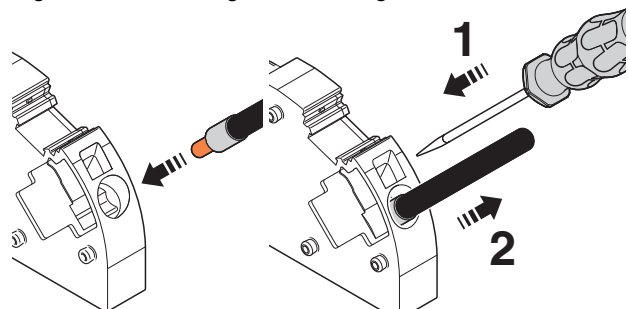

- For small conductor cross sections and flexible conductors without ferrules, you first have to open the terminal point.
- To release the conductor, insert a screwdriver into the slot above the connection.

4.3 Push-Lock connection

Series

PLW 16-6...

Example

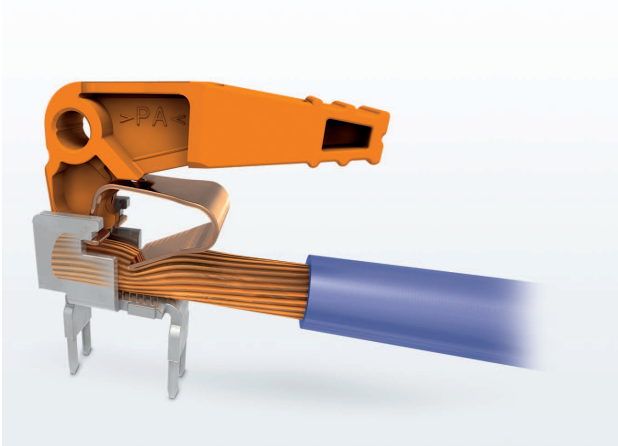

Figure 16 Push-Lock connection

The push-lock spring enables easy and tool-free conductor connection with or without ferrules by means of the one-handed tilting lever.

Connecting the conductor

We recommend protecting the terminal block from mechanical stress.

The lever must be open for the push-lock connection.

- Strip off the conductor.
-
- Insert the conductor centrally into the round cable opening of the terminal block all the way to the stop.
- Press the lever all the way down to clamp in the wire.

Figure 17 Inserting the conductor

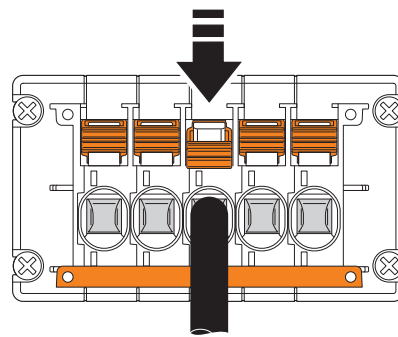

- To release the wire, open the lever.

Wires with a cross-section $\geq 2.5 \text{ mm}^2$, rigid or flexible with ferrule, can also be connected when the lever is closed.

Figure 18 Closed terminal point

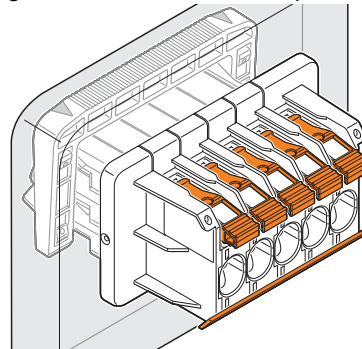

Be sure to actually press the lever all the way down, because the connection can not be ensured otherwise.

4.4 T-LOX knee-lever connection

Series

TW 50...

TW 95...

Example

Figure 19 T-LOX

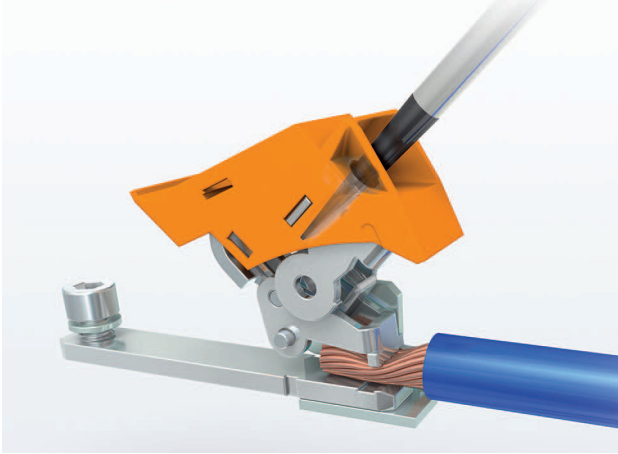

The T-LOX knee-lever connection enables you to connect large conductor cross sections with ease. Their operating mechanism is based on a spring that generates a programmed contact force. The conductors can be swiveled into the terminal point.

Connecting the conductor

We recommend protecting the terminal block from mechanical stress.

Unlike usually, the conductor needs to be placed into the terminal block from above, not inserted into it from the front.

Figure 20 Inserting the conductor

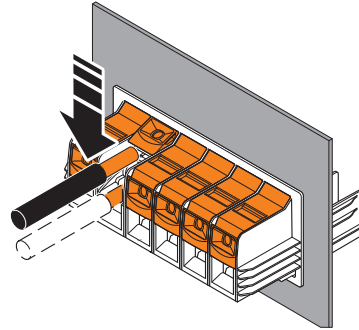

- Strip off the conductor.
- Swivel the conductor from above into the terminal block.

Closing the terminal point

- To close the terminal point, insert the recommended screwdriver into the round opening of the orange cover cap.

Figure 21 Closing the terminal point

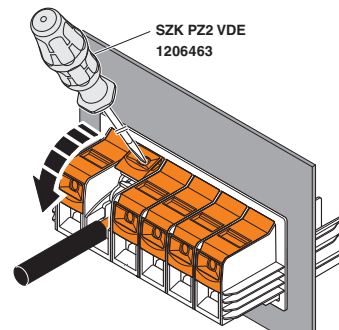

Opening the terminal point

- To close the terminal point, insert the recommended screwdriver into the round opening of the orange cover cap.



NOTE: Damage to the item

The item may be damaged if the terminal point is jerked open. Open the lever in a controlled manner using a screwdriver.

4.5 Bolt connection

Series

Conductors are connected on the inside of terminals from the HDFK, PW, UW, and TW series.

Example

Figure 22 Bolt connection

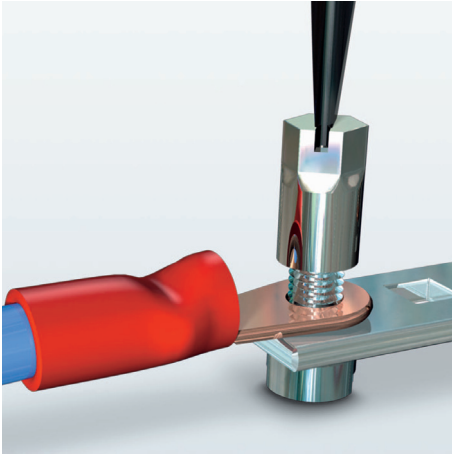

The bolt connection technology was specifically developed to allow for the wiring of ring and fork-type cable lugs.

Connecting the conductor

- Strip off the conductor. Provide the conductor with a ring cable lug in accordance with DIN 46234. The stripping length depends on the ring cable lug.
- Crimp the ring cable lugs using suitable crimping pliers. Ensure that the test requirements are met.
- Insulate the cable lugs using a shrink sleeve. Use shrink sleeves that meet the following minimum requirements:
 - Electric strength > 19.7 kV/mm (IEC 60243)
 - Wall thickness (fully shrunk) ≥ 0.5 mm
- Insert the ring cable lug, the washer, and the screw into the connection point in this order.

Figure 23 Inserting the conductor (example shows TW...-CL...)

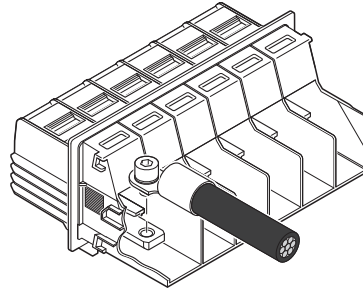

- Tighten the screw to the specified torque.

4.6 Soldering or spade connection

Series

Conductors are connected on the inside of molded terminal blocks from the PW and VDFK series.

Solder connection

Figure 24 Connecting the conductor (PW...-POT-SL...)

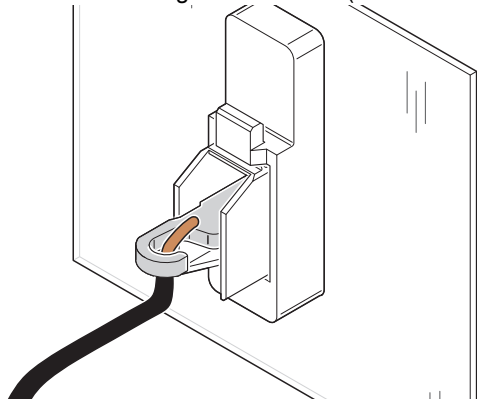

- From below, insert the stripped conductor through the hook. Solder the conductor.

Spade connection

Figure 25 Connecting the conductor (PW...-POT-SCM...)

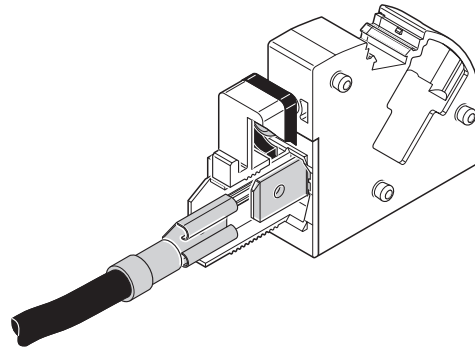

- Connect the conductor with push-on sleeve to the spade connector in the housing.

5 How to use aluminum conductors

5.1 Suitable panel feed-through terminals

You can connect the marked aluminum conductors to the panel feed-through terminal blocks listed below, if the aluminum conductors meet these requirements:

Conductor structure according to DIN VDE 0276-603 or IEC 60502-1

- round, single-strand, class 1 according to IEC/EN 60228
- ▽ sector-shaped, single-strand, class 1 according to IEC/EN 60228, $\alpha = 90^\circ$

Sector-shaped means the conductor structure looks like this:

Figure 26 Structure of sector-shaped conductors

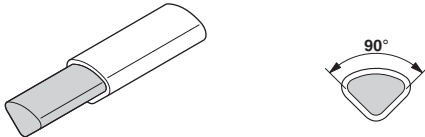

Designation	Order No.	Conductor cross section [mm ²]							
		6	10	16	25	35	50	70	95
HDFK series									
HDFK 25	0707743	•	•	•	•				
HDFK 25 GNYE	0707769	•	•	•	•				
HDFK 25-PE	0707785	•	•	•	•				
HDFK 25-VP	0709136	•	•	•	•				
HDFK 25-VP GNYE	0709149	•	•	•	•				
HDFKV 25	0709039	•	•	•	•				
HDFKV 25 GNYE	0709042	•	•	•	•				
HDFKV 25-VP	0708962	•	•	•	•				
HDFK 50	0708739					•	▽		
HDFK 50 GNYE	0708726					•	▽		
HDFK 50-VP	0709123					•	▽		
HDFK 50-VP GNYE	0708991					•	▽		
HDFKV 50	0708522					•	▽		
HDFKV 50 GNYE	0708548					•	▽		
HDFKV 50-VP	0708580					•	▽		
HDFKV 50-VP BU	0717403					•	▽		
HDFKV 50-VP GNYE	0708797					•	▽		
HDFK 95	0709534							▽	▽
HDFK 95 BU	0717584							▽	▽
HDFK 95-F	0709644							▽	▽
HDFK 95-F-VP	0709916							▽	▽
HDFK 95-F-VP GNYE	0717665							▽	▽
HDFK 95-VP	0717979							▽	▽
HDFKV 95	0709547							▽	▽
HDFKV 95-DP	0709660							▽	▽
HDFKV 95-F	0709673							▽	▽
UW series									
UW 16	3073348	•	•	•	•				
UW 16-POT	3073487	•	•	•	•				
UW 16-POT/S	3073490	•	•	•	•				
UW 16/S	3073351	•	•	•	•				
UWV 16	3073419	•	•	•	•				
UWV 16-POT	3073542	•	•	•	•				
UWV 16-POT/S	3073555	•	•	•	•				
UWV 16/S	3073432	•	•	•	•				
UW 25	3073364	•	•	•	•	•			

Designation	Order No.	Conductor cross section [mm ²]							
		6	10	16	25	35	50	70	95
UW 25-POT	3073500	•	•	•	•	•			
UW 25-POT/S	3073513	•	•	•	•	•			
UW 25/S	3073377	•	•	•	•	•			
UWV 25	3073445	•	•	•	•	•			
UWV 25-POT	3073568	•	•	•	•	•			
UWV 25-POT/S	3073571	•	•	•	•	•			
UWV 25/S	3073458	•	•	•	•	•			
TW series									
TW 50/ 1-CL	1708744			•	•	•	▽		
TW 50/ 2-CL	1708745			•	•	•	▽		
TW 50/ 3-CL	1708746			•	•	•	▽		
TW 50/ 4-CL	1708748			•	•	•	▽		
TW 50/ 5-CL	1708749			•	•	•	▽		
TW 50/ 6-CL	1708751			•	•	•	▽		
TW 95/ 1-CL	1708752			•	•	•	▽	▽	▽
TW 95/ 2-CL	1708753			•	•	•	▽	▽	▽
TW 95/ 3-CL	1708754			•	•	•	▽	▽	▽
TW 95/ 4-CL	1708755			•	•	•	▽	▽	▽
TW 95/ 5-CL	1708756			•	•	•	▽	▽	▽
TW 95/ 6-CL	1708757			•	•	•	▽	▽	▽

5.2 Connecting aluminum conductors

Make sure the installation site is kept as free from humidity or aggressive atmospheres as possible.

- Remove the insulation from the cable.
- Use a knife to carefully scrape the oxide layer off the stripped aluminum conductor.
- Immediately afterwards, grease the conductor end with some non-acid and non-alkali grease. An example of a suitable grease is technical grade petroleum jelly.
- Connect the aluminum conductor to the panel feed-through terminal block directly after greasing it.
- Tighten the screw of the panel feed-through terminal block with the maximum permissible torque.
- Repeat all steps when the aluminum conductor needs to be reconnected.

Connecting sector-shaped conductors

- Always place sector-shaped conductors as shown in [Figure 27](#).

Figure 27 TW....

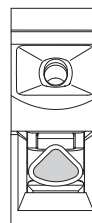

UW.../HDFK...

