

New Toaster Controller

Features

- Operating voltage: 3.5V~5.5V.
- Have Defrost, Reheat and Bagel function
- Relay output disable without external oscillator
- Adjustable timer: 30s~10mins
- Few external components
- Low cost 8-Pin DIP package

Applications

- Toaster Controller

Description

The PT8A2514A is a CMOS LSI chip designed for toasters application. It will use different timer when different function was active, and the time can be adjusted by external R/C. It has Reheat, Defrost, Bagel function.

The chip includes: Power on reset circuit, Logic control circuit, Output driver circuit, Key scan circuit, timer circuit, Built-in internal oscillator and external R/C oscillator circuit etc. It is enclosed in lead free DIP-8 package.

Pin Configuration

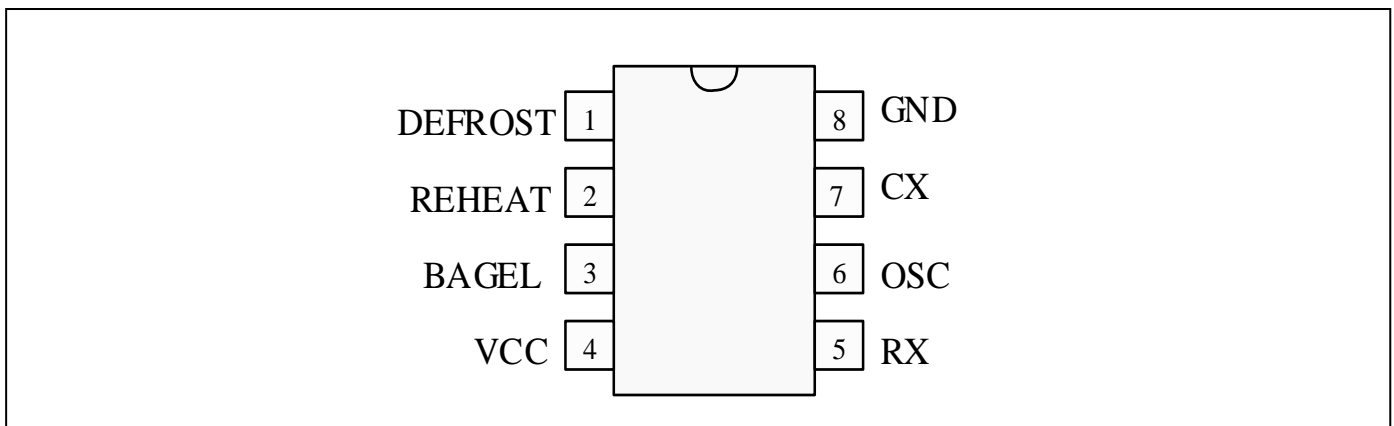

Pin Description

Pin No.	Pin Name	I/O	Description
1	Defrost	I/O	As input, requires a negative pulse to active "Defrost" function. As output, gives a "Defrost" function indicator, active low.
2	Reheat	I/O	As input, requires a negative pulse to active "Reheat" function. As output, gives a "Reheat" function indicator, active low.
3	Bagel	I/O	As input, requires a positive pulse to active "Bagel" function. As output, gives a "Bagel" function indicator, active high.
4	VCC	I	Power supply
5	RX	O	Shorts to VCC when Reheat function is active.
6	OSC	I/O	Oscillator's Frequency of 8.192KHz with an external R1, C1.
7	CX	O	Shorts to GND when defrost function is active.
8	GND	I	Ground

Maximum Ratings

Storage Temperature.....	- 40°C to +125°C
Supply Voltage to Ground Potential (Inputs & V _{CC} only).....	- 0.5 to V _{CC} +0.5V
Supply Voltage to Ground Potential (Outputs & D/O only) ...	- 0.5 to V _{CC} +0.5V
DC Input Voltage	- 0.5V to V _{CC} +0.5V
DC Output Current	20mA
Power Dissipation.....	500mW

Note:

Stresses greater than those listed under MAXIMUM RATINGS may cause permanent damage to the device. This is a stress rating only and functional operation of the device at these or any other conditions above those indicated in the operational sections of this specification is not implied. Exposure to absolute maximum rating conditions for extended periods may affect reliability.

Recommended Operation Conditions

Sym	Description	Min	Typ	Max	Unit
V _{CC}	Supply voltage.	3.5	5.0	5.5	V
V _{IH}	“H” Input Voltage	0.8 V _{CC}	-	-	V
V _{IL}	“L” Input Voltage	-	-	0.35 V _{CC}	V
T _A	Operation temperature	0	25	85	°C

DC Electrical Characteristics

(Unless otherwise noted, V_{CC}= 5V, T_A = 0 ~ 85 °C)

Symbol	Parameter	Test Condition	Min	Typ	Max	Unit
V _{IL}	Input “L” Voltage (Defrost, Reheat)	-	-	-	2.5	V
V _{IH}	Input “H” Voltage (Bagel)	-	2.5	--	-	V
I _{OH1}	Output Source Current (Defrost, Reheat)	V _{OH} =4.5V, Input key scan	-5	--	-40	uA
I _{OH2}	Output Source Current (Defrost, Reheat)	V _{OH} =4.5V, Drive load	-10	-	-	mA
I _{OH3}	Output Source Current (Bagel)	V _{OH} =4.5V	-10	-	-	mA
I _{OH5}	Output Source Current (RX)	V _{OH} =4.5V	-1.5	-	-	mA
I _{OL1}	Output Sink Current(Defrost, Reheat)	V _{OL} =0.5V	4	-	-	mA
I _{OL2}	Output Sink Current(Bagel)	V _{OL} =0.5V	10	--	100	uA
I _{OL3}	Output Sink Current(CX)	V _{OL} =0.5V	4.0	-	-	mA
I _{IH}	Input high leakage current(CX,RX)	V _{IH} =5V	-	-	-1	μA
I _{IL}	Input low leakage current(CX,RX)	V _{IL} =0V	-	-	1	μA
OSC	Frequency of normal oscillator	R1=47KΩ C1=332, see Fig 1	7808	8192	8576	Hz
I _{CC}	Power supply current	V _{CC} =5V, R1=47 KΩ, C1=332, all output floating. See Fig 1	-	-	500	μA

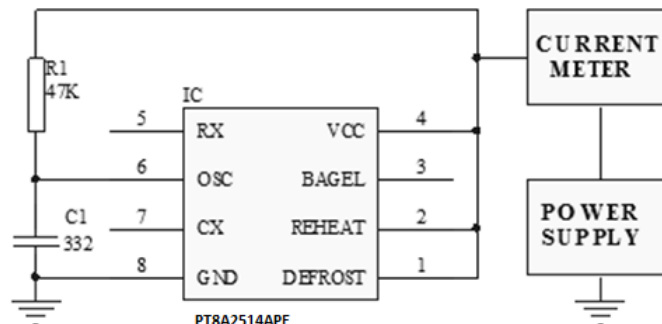
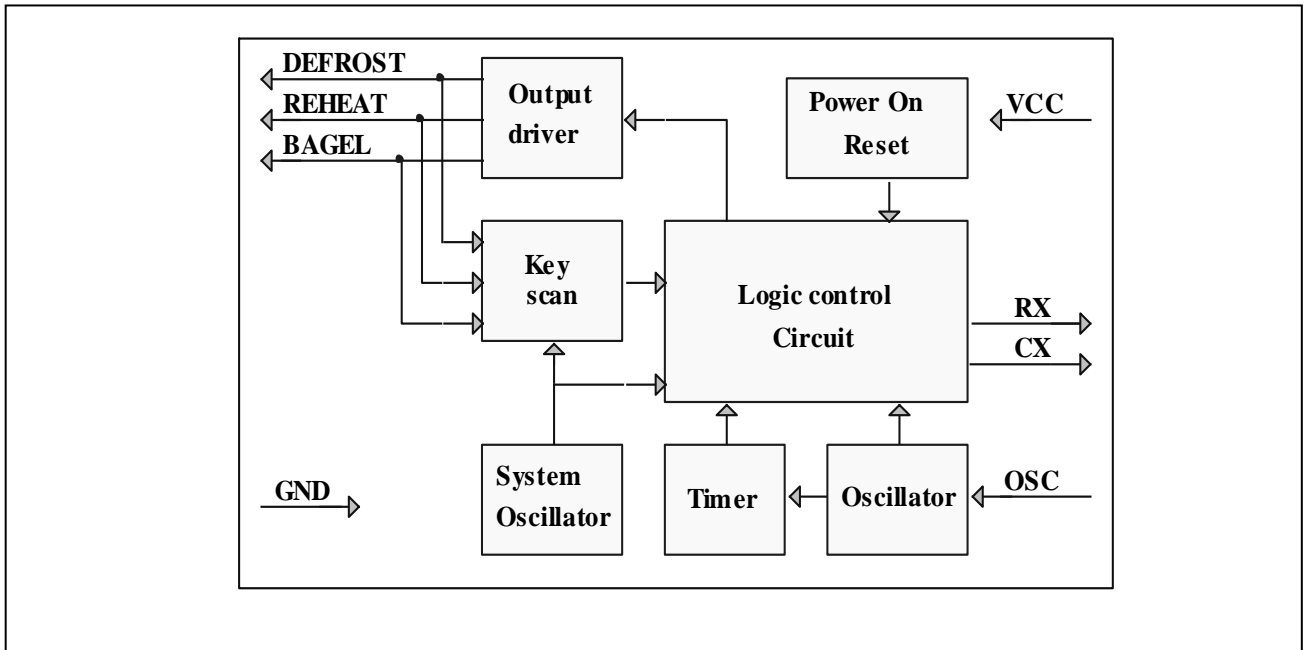

Fig1 Test circuit

Block Diagram



Function Description (Refer to Block Diagram)

The chip mainly includes: Power on reset circuit, Logic control circuit, Output driver circuit, Key scan circuit, timer circuit, external R/C oscillator circuit and internal oscillator circuit etc.

Power on reset circuit

Internal power on reset circuit will reset all the logic circuit and the timer; it will clear all output pins when power on.

Logic control circuit

The logic circuit will carries out all the logic control function. It will scan key status, then control the output drive circuit drive a LED to indicate the work status, at the same time it will control CX or RX output to change the frequency of oscillator. When timer is out, it will pull down Defrost, Reheat pins to release relay.

Output driver circuit

The pin DEFROST, REHEAT and BAGEL, will drive a LED to indicate work status, at the same time DEFROST and REHEAT pin will driver a relay. BAGEL pin will drive a relay when bagel function is active, and it will drive a LED to indicate the bagel status.

Key scan circuit

This circuit will detect the key status, when DEFROST or REHEAT key have a low negative pulse, it will active the corresponding work status. When BAGEL key have a high positive pulse, it will active the corresponding work status.

Note: For PT8A2514A, DEFROST or REHEAT key, if one key press, another lock up accordingly. BAGEL key is independent.

Timer circuit

This circuit will provide a timer to logic control circuit. When $F_{osc} = 8.192\text{KHz}$, timer output is $245720/8192=30s$.

External R/C Oscillator circuit

This circuit will produce a system frequency depend on external resistor and cap. The frequency is about 8.192KHz when $R1=47\text{K}\Omega$ and $C1=332$. (Refer to Fig 1).

Note: The system frequency with external resistor and cap must be between 200Hz to 20KHz.

Internal oscillator

An on-chip RC oscillator with frequency about 256 KHz is used to check the input signal and the wrong statue of external RC oscillator.

Typical Application Circuit

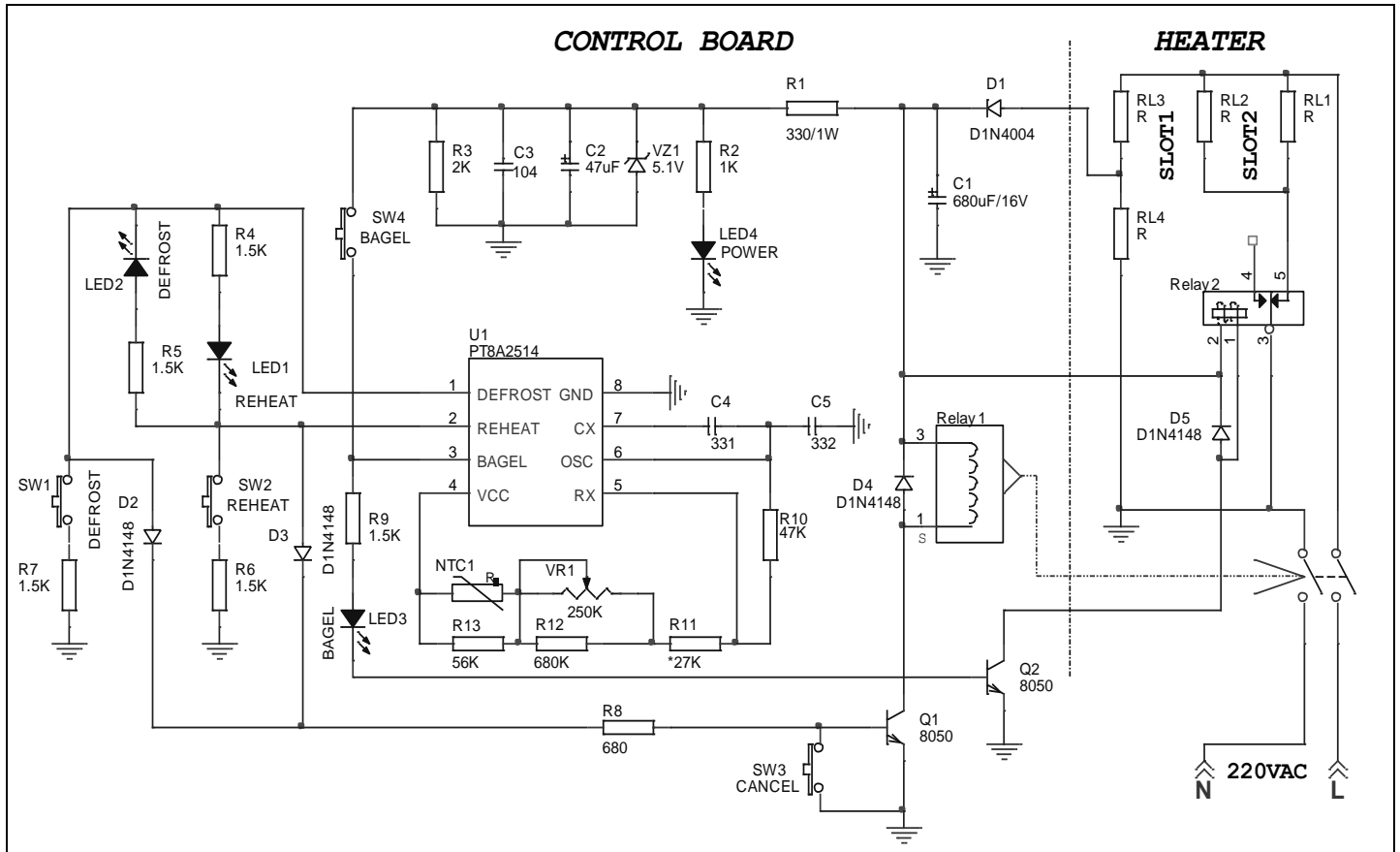

Mechanical Information

PE (Lead free DIP-8)

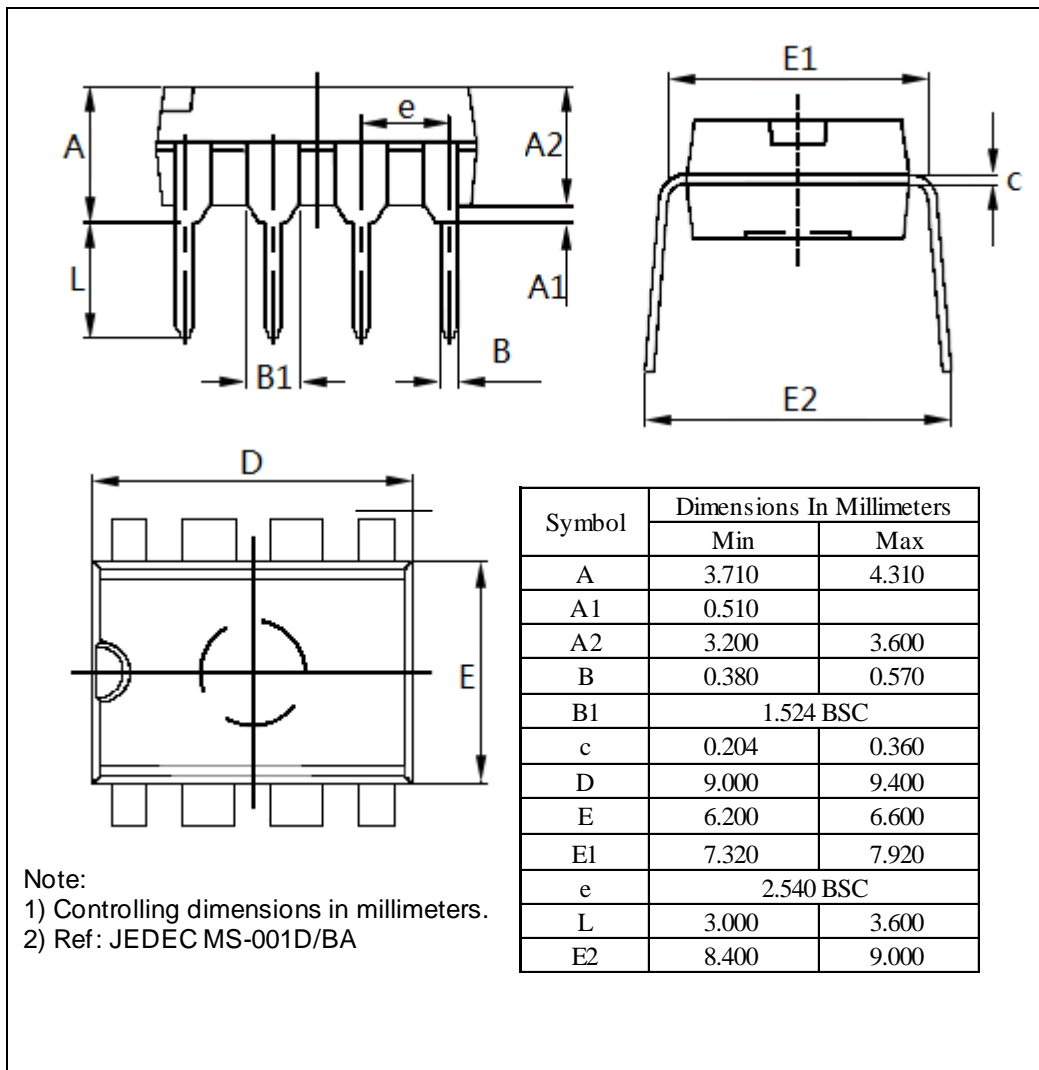

Ordering Information

Part No.	Package Code	Package
PT8A2514APE	P	Lead free DIP-8

Note:

- E = Pb-free
- Adding X Suffix= Tape/Reel

Function comparison table

PT8A2514A	DEFROST and REHEAT key interlock each other, and BEGAL key is individual
-----------	--

Pericom Semiconductor Corporation • 1-800-435-2336 • www.pericom.com

Pericom Technology Incorporation reserves the right to make changes to its products or specifications at any time, without notice, in order to improve design or performance and to supply the best possible product. Pericom Technology does not assume any responsibility for use of any circuitry described other than the circuitry embodied in Pericom Technology product. The company makes no representations that circuitry described herein is free from patent infringement or other rights, of Pericom.

Mouser Electronics

Authorized Distributor

Click to View Pricing, Inventory, Delivery & Lifecycle Information:

[Diodes Incorporated:](#)

[PT8A2514APE](#)