

EVB CONNECTOR

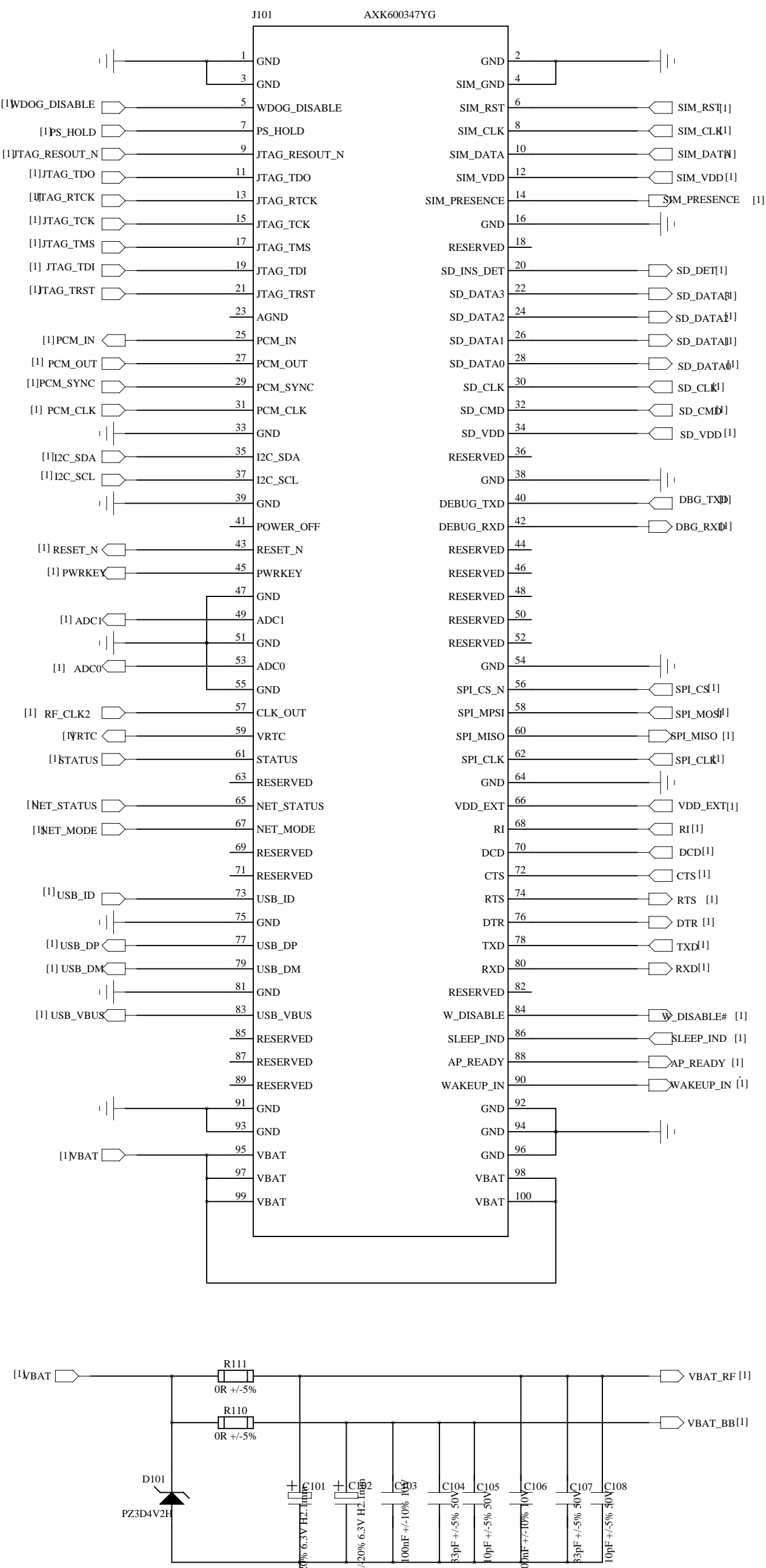

EC200T

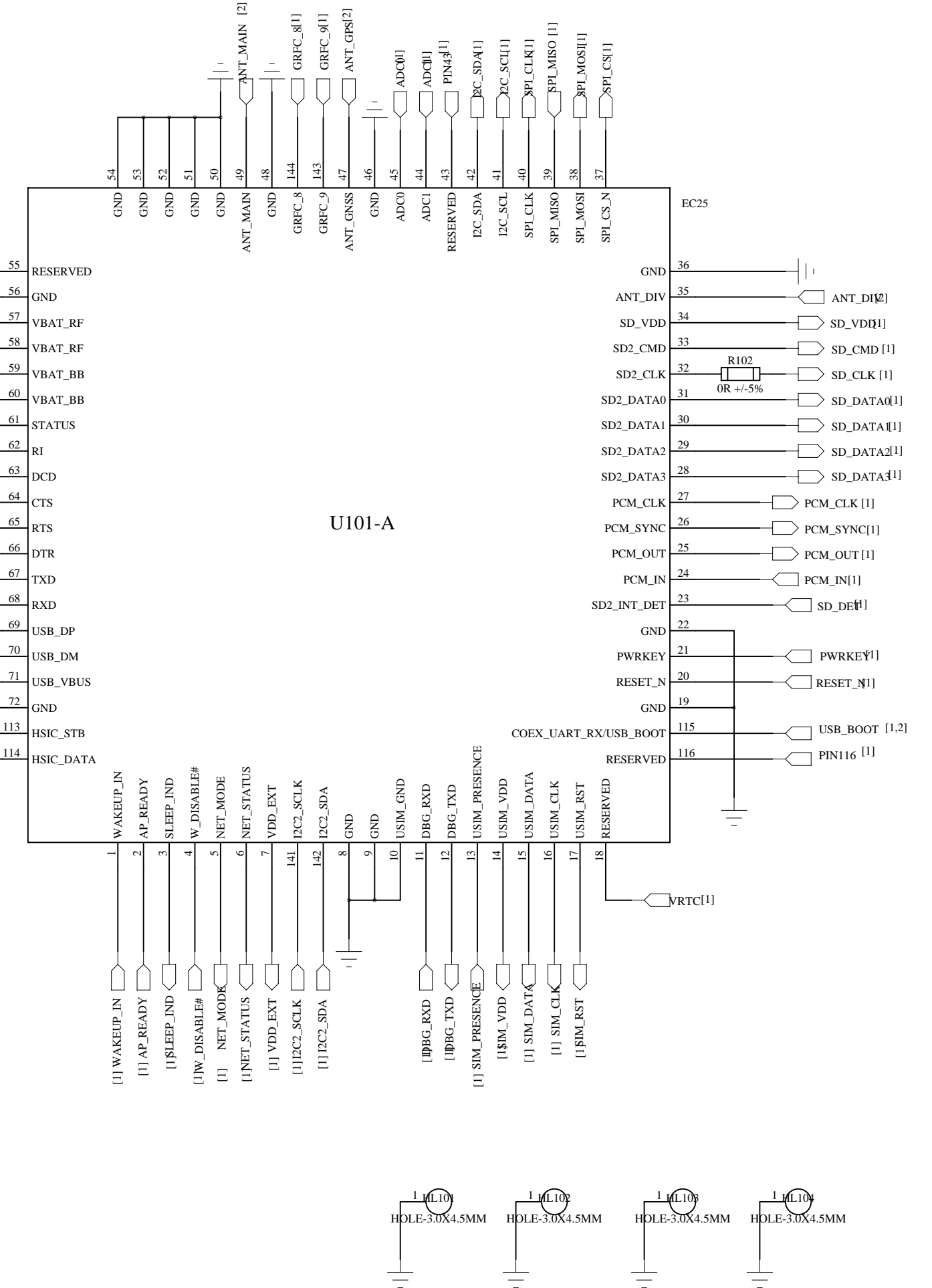
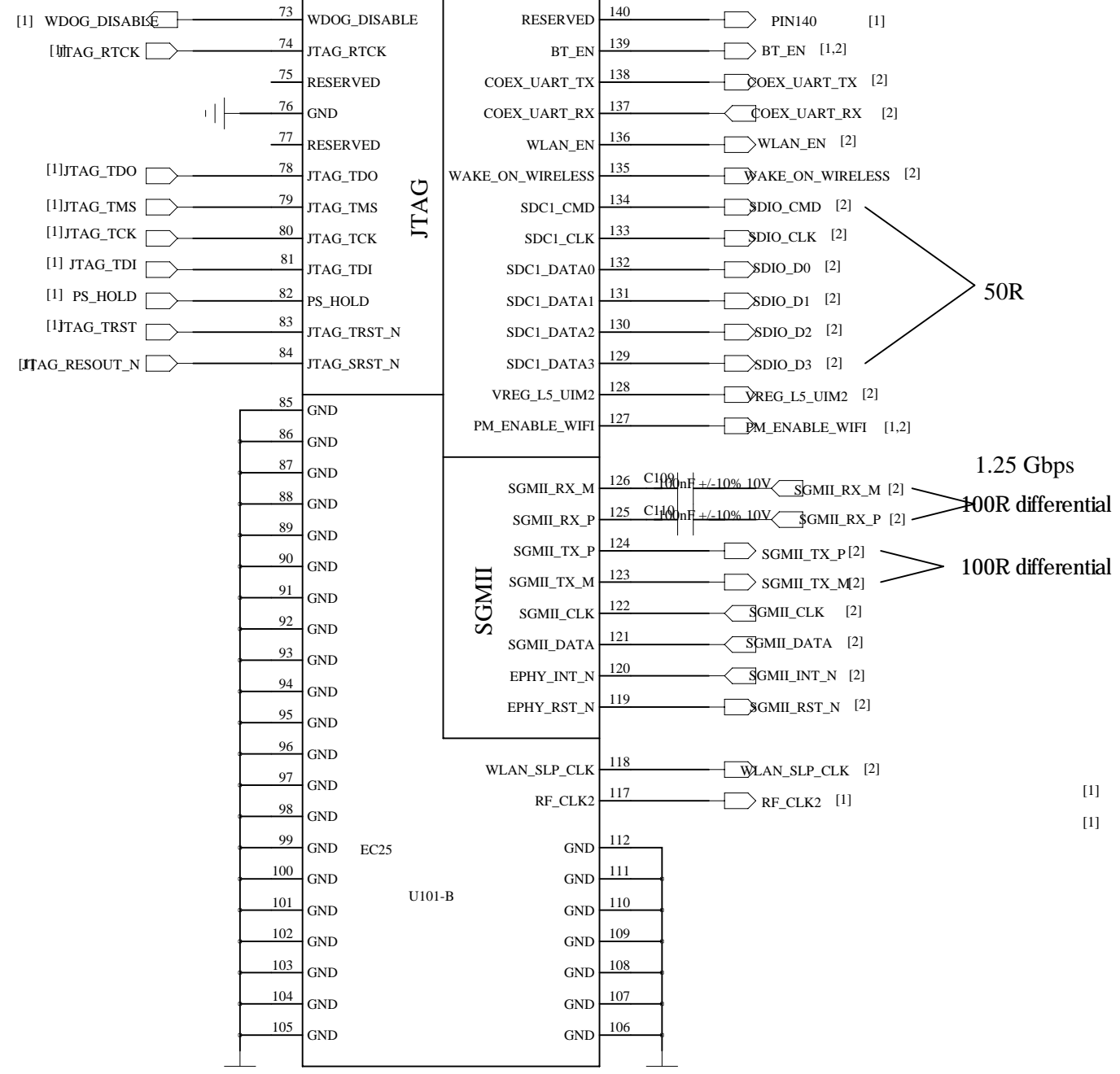
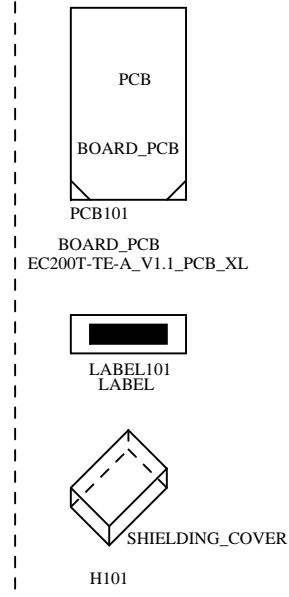

Testpoints

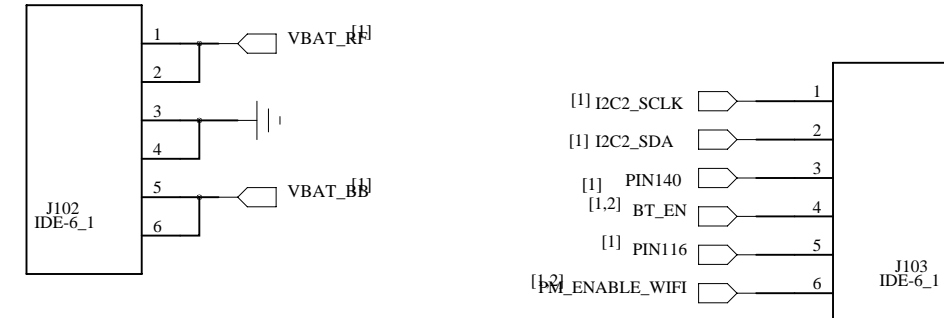

| | | |
|-----------------------------------|------------------------|------------------|
| Quectel Wireless Solutions | | |
| DRAWN BY Fanny Chen | PROJECT EC200T-TE-A | TITLE <Title> |
| CHECKED BY Woody Wu | SIZE A2 | VER V1.1 |
| SHEET 1 OF 2 | DATE 2019/3/12 | |

WLAN+BT&SGMII CONNECTOR

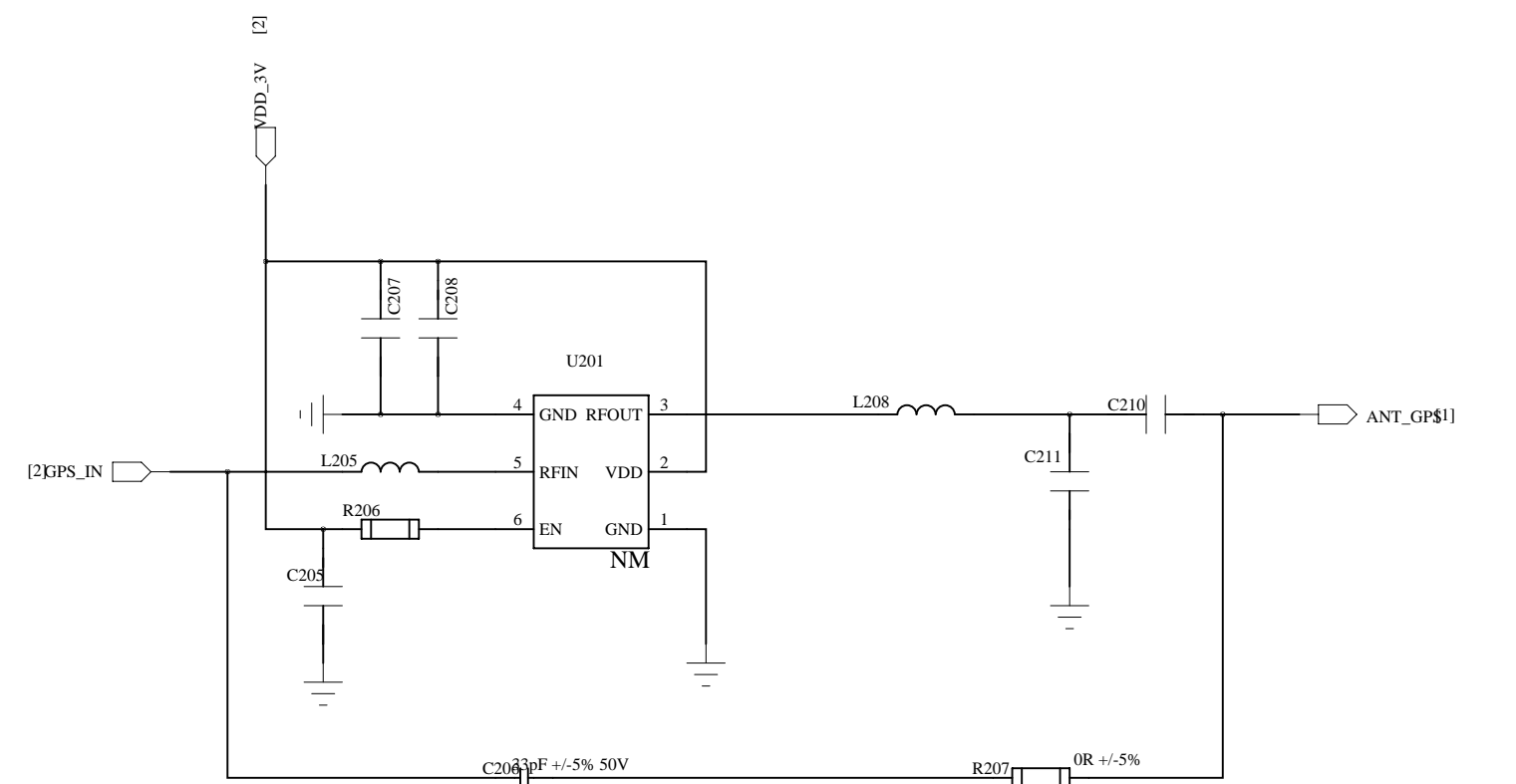
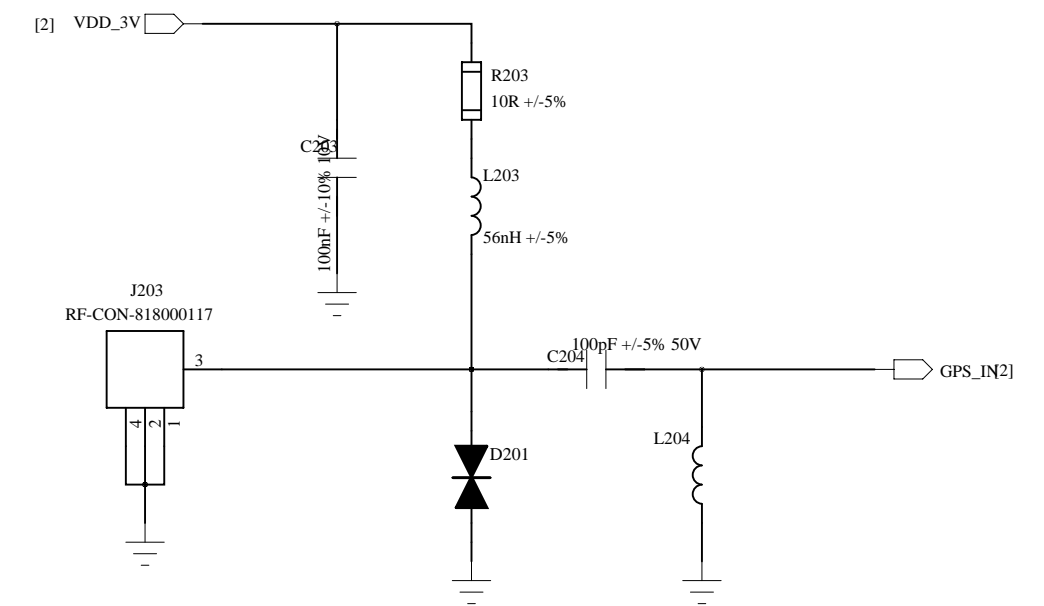
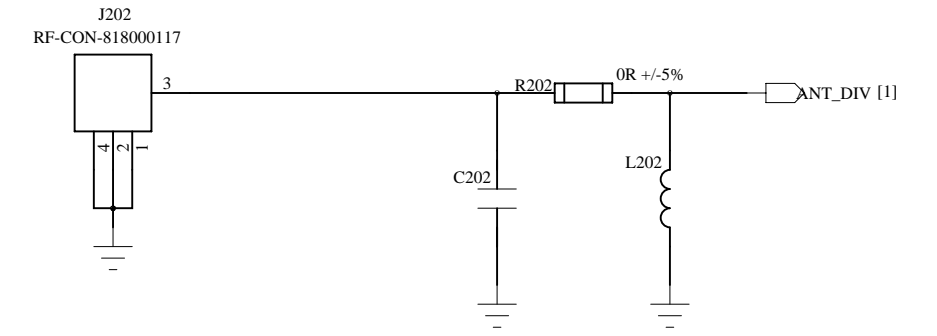
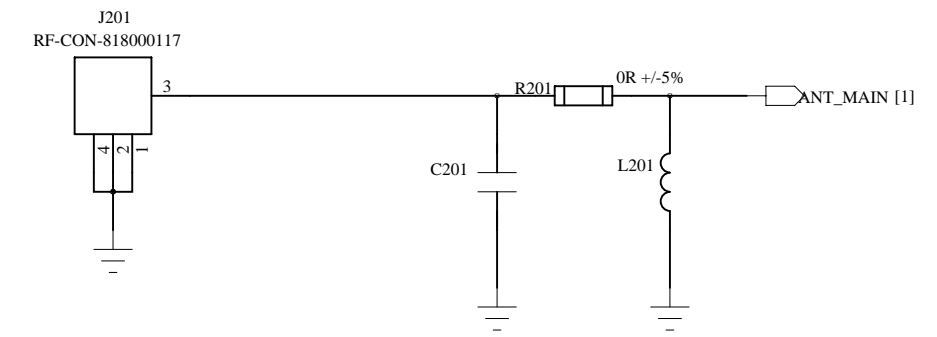
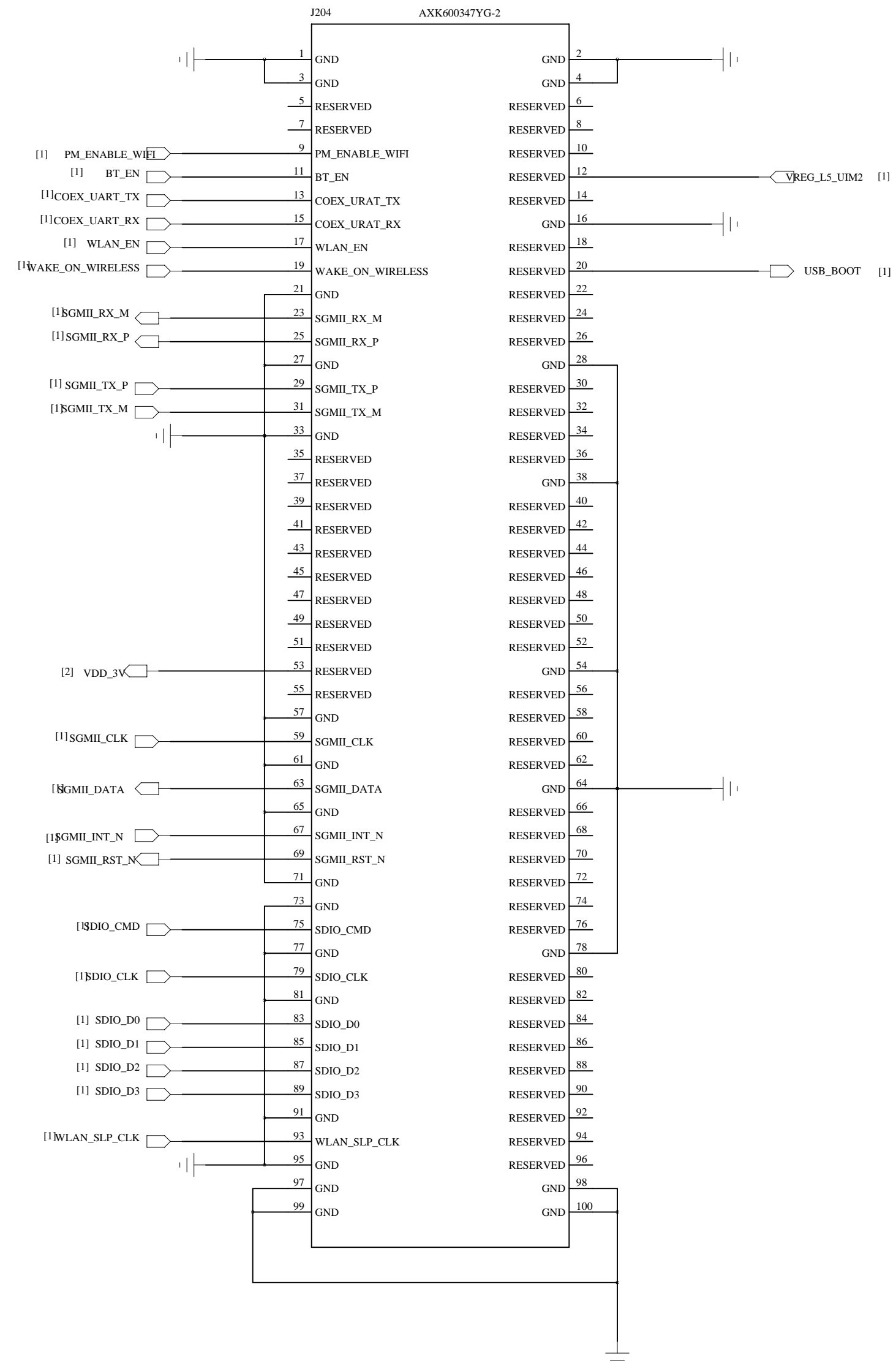

| | | | |
|-----------|------|------|------|
| | UC20 | EC20 | EC25 |
| LNA | Y | N | N |
| C206/R207 | N | Y | Y |

Quectel Wireless Solutions

| | | |
|------------------------|------------------------|------------------|
| DRAWN BY Fanny Chen | PROJECT EC200T-TE-A | TITLE <Title> |
| CHECKED BY Woody Wu | SIZE A2 | VER V1.1 |
| SHEET 2 OF 2 | DATE 2019/3/12 | |