

## MICROCIRCUIT SP3232N, SP3232D INTERFACE TRANSCEIVER OF THE SERIAL DATA OF THE STANDARD RS -232

The interface transceiver of the serial data of the standard RS - 232 SP3232 with the single supply voltage and bipolar output voltage of the transmitter, formed by means of the built-in voltage multiplication oscillator at four external capacitances, equal to 0.1 uF, corresponding to the standards of EIA/TIA-232E, V.28, is intended for application in the contemporary high efficiency computing systems with the wide range of the supply voltage, fast response electron devices with the high reliability of the exchange information among the remote objects.

Performed functions, composition and structure:

Microcircuit contains 2 transmitters and 2 receivers of the serial data of the standard RS-232. The microcircuit supply voltage range is from 3.0 to 5.5 V.

Microcircuit is fabricated in the 16-pin DIP-package MS-001BB and in the 16-pin SO-package MS-012AC.

### Truth Table

Input	Output
RXIN, TXIN	$\overline{\text{RXOUT}}, \overline{\text{TXOUT}}$
H	L
L	H

Note –  
L – low voltage level;  
H – high voltage level

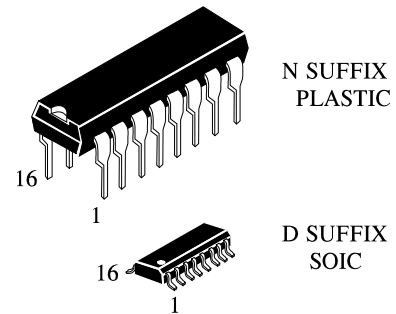

### IC marking in package

SP3232N Plastic DIP

SP3232D SOIC

T<sub>A</sub>= from -40 to 85 °C

For all packages

### Pinning

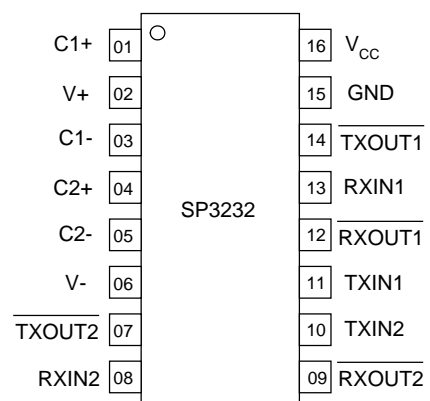

**Functional electric circuit**

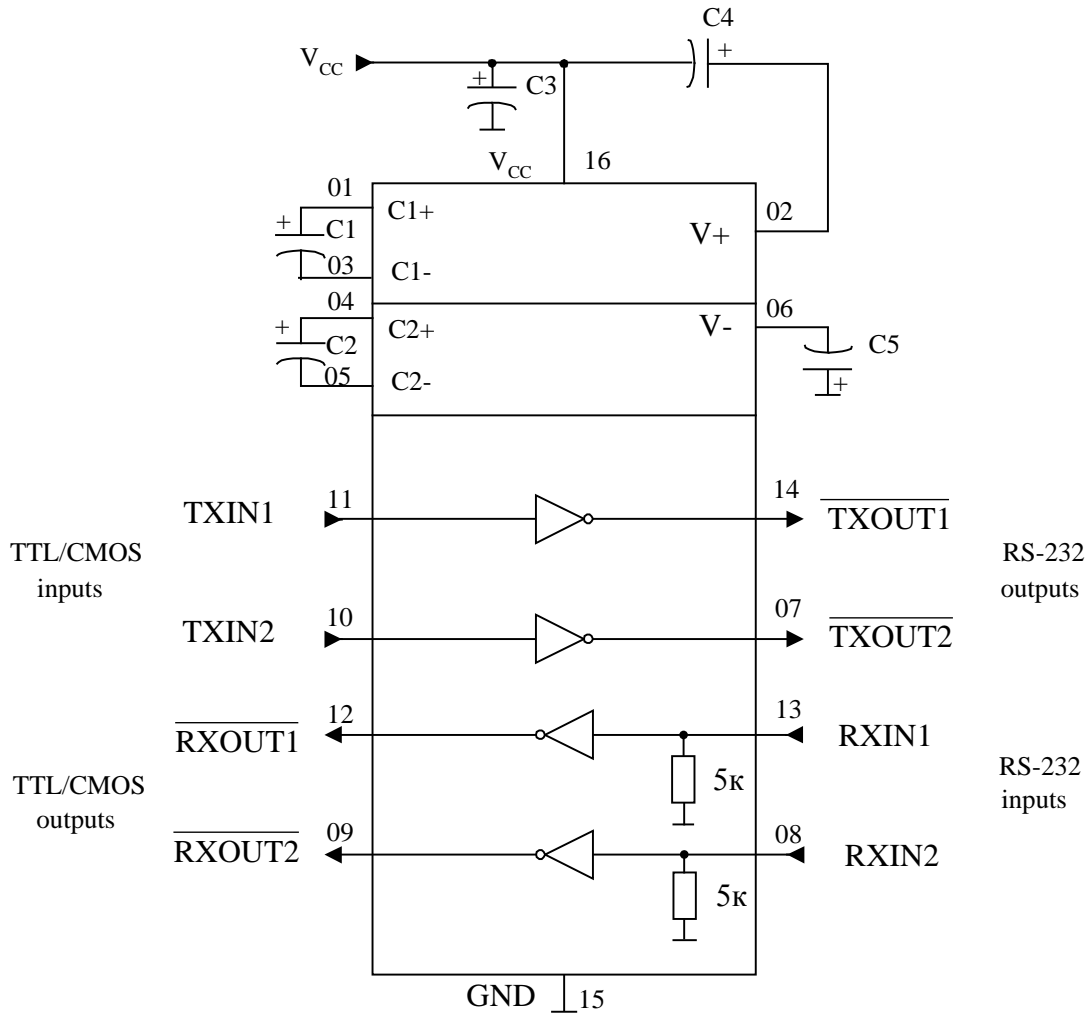

C1 – capacitor with capacitance of 0.1 uF ± 10 % at  $U_{CC} = 3.3\text{ V} \pm 10\%$  and 0.047 uF ± 10 % UF at  $U_{CC} = 5.0\text{ V} \pm 10\%$

C2, C4, C5– capacitors with capacitance of 0.1 uF ± 10 % at  $U_{CC} = 3.3\text{ V} \pm 10\%$  and 0.33 ± 10 % uF at  $U_{CC} = 5.0\text{ V} \pm 10\%$

C3 – capacitor with capacitance of 0.1 uF ± 10 %

**Pin description table**

Number	Pin Description	Identification
01	External capacitance pin of the positive voltage multiplication block	C1+
02	Output of the multiplication block positive voltage	V+
03	External capacitance pin of the positive voltage multiplication block	C1-
04	External capacitance pin of the negative voltage multiplication block	C2+
05	External capacitance pin of the negative voltage multiplication block	C2-
06	Output of the multiplication block negative voltage	V-
07	Transmitter output (levels RS-232)	$\overline{\text{TXOUT2}}$
08	Receiver input (levels RS-232)	RXIN2
09	Receiver output (levels TTL/CMOS)	$\overline{\text{RXOUT2}}$
10	Transmitter input (levels TTL/CMOS)	TXIN2
11	Transmitter input (levels TTL/CMOS)	TXIN1
12	Receiver output (levels TTL/CMOS)	$\overline{\text{RXOUT1}}$
13	Receiver input (levels RS-232)	RXIN1
14	Transmitter output (levels RS-232)	$\overline{\text{TXOUT1}}$
15	Common pin	GND
16	Supply pin from voltage source	V <sub>CC</sub>

**Maximum & Absolute maximum rating**

Parameter, Unit	Symbol	Absolute maximum rating		Maximum rating	
		Min	Max	Min	Max
Supply voltage, V	U <sub>CC</sub>	3.0	5.5	-0.3	6
Voltage at transmitter output, V	U <sub>OT</sub>	–	–	-13.2	13.2
Positive voltage at multiplication block output, V	U <sub>OV+</sub>	5.0	–	-0.3	7.0
Negative voltage at multiplication block output, V	U <sub>OV-</sub>	-5.0	–	-7.0	0.3
Receiver input voltage, V	U <sub>IR</sub>	-25	25	-25	25
Receiver output voltage, V	U <sub>OR</sub>	–	–	-0.3	U <sub>CC</sub> +0.3
Low level transmitter input voltage, V	U <sub>IL</sub>	0	0.8	-0.3	
High level transmitter input voltage, V	U <sub>IH</sub>	2.0 (U <sub>CC</sub> =3.3 V)	U <sub>CC</sub>	–	6
		2.4 (U <sub>CC</sub> =5.0 V)			
Voltages total at the positive and negative pins of the voltage multiplication block, V	U <sub>V+</sub> + U <sub>V-</sub>	–	–	–	13
Ambient temperature, °C	T <sub>a</sub>	-40	85	-65	150

**Electric Parameters** (C1=0.047 uF, C2-C4 = 0.33 uF at U<sub>CC</sub> = 5.0 V ±10%, C1-C4 = 0.1 uF at U<sub>CC</sub>=3.3 V ±10%, Ta= -40 ÷ 85°C, if not indicated otherwise)

Parameter, Unit	Symbol	Measurement Mode	Norm		
			Min	Max	
Static consumption current, mA	I <sub>CC</sub>	Outputs in the idle run mode, Ta = 25°C, U <sub>CC</sub> = 3.3 V or 5.0 V	-	1.0	
Transmitter leakage input current, uA	I <sub>I</sub>	-	-	±1	
Low level receiver output voltage, V	U <sub>OL</sub>	I <sub>OUT</sub> = 1.6 mA	-	0.4	
High level receiver output voltage, V	U <sub>OH</sub>	I <sub>OUT</sub> = -1.0 mA	U <sub>CC</sub> -0.6		
Receiver input voltage, V	U <sub>IR</sub>	-	-25	25	
Low level receiver input threshold voltage, V	U <sub>THL</sub>	Ta = 25°C	U <sub>CC</sub> = 3.3 V	0.6	-
			U <sub>CC</sub> = 5.0 V	0.8	-
High level receiver input threshold voltage, V	U <sub>THH</sub>	Ta = 25°C	U <sub>CC</sub> = 3.3 V	-	2.4
			U <sub>CC</sub> = 5.0 V	-	2.4
Receiver input resistance, kOhm	R <sub>INR</sub>	Ta = 25°C	3	7	
Variation range of receiver output voltage, V	U <sub>OT</sub>	Outputs of transmitters are connected to the zero potential via the resistors 3 kOhm	±5	-	
Transmitter output resistance, Ohm	R <sub>OT</sub>	U <sub>CC</sub> = U <sub>V+</sub> = U <sub>V-</sub> = 0 V, U <sub>TOUT</sub> = ±2 V	300		
Transmitter short circuit output current, mA	I <sub>OST</sub>	-	-	±60	
Maximum rate of the information transfer, kbit/sec	ST	R <sub>L</sub> = 3 kOhm, C <sub>L</sub> = 1000 pF, one transmitter is switched over	120	-	
Alteration rate of the transmitter output front, V/usec	SR	U <sub>CC</sub> = 3.3 V, R <sub>L</sub> = 3-7 kOhm, Ta = 25°C, U <sub>OT</sub> = 3 ÷ -3 V or -3 ÷ 3V, one transmitter is switched.	C <sub>L</sub> = =150-1000 pF	6	30
			C <sub>L</sub> = =150-2500 pF	4	30

**Time chart of the receiver's input and output signals**

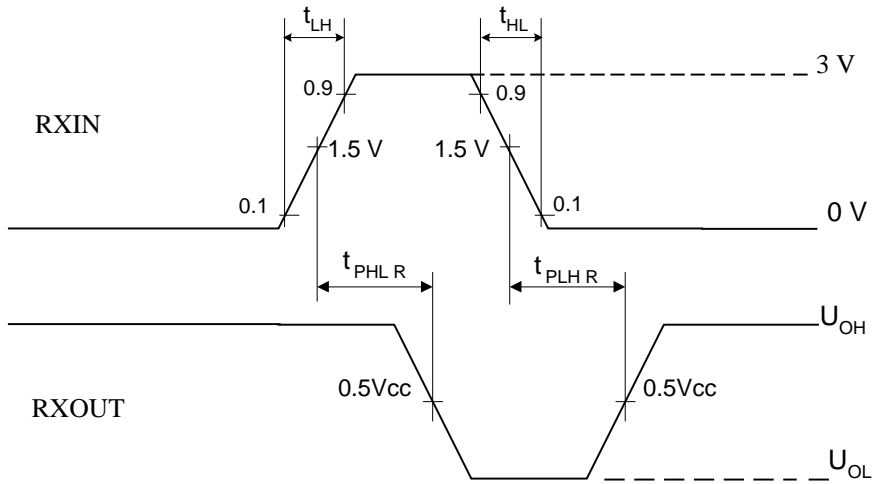

**Time chart of the transmitter's input and output signals**

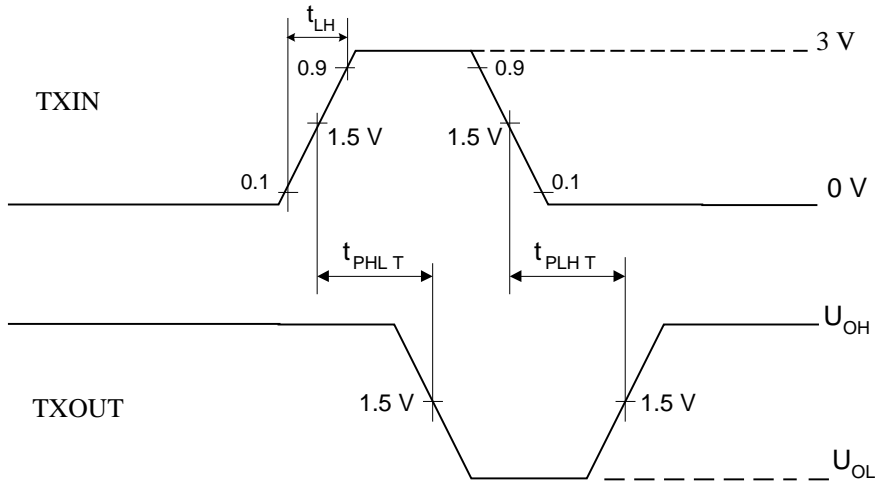

**Time chart of the transmitter's input and output signals**

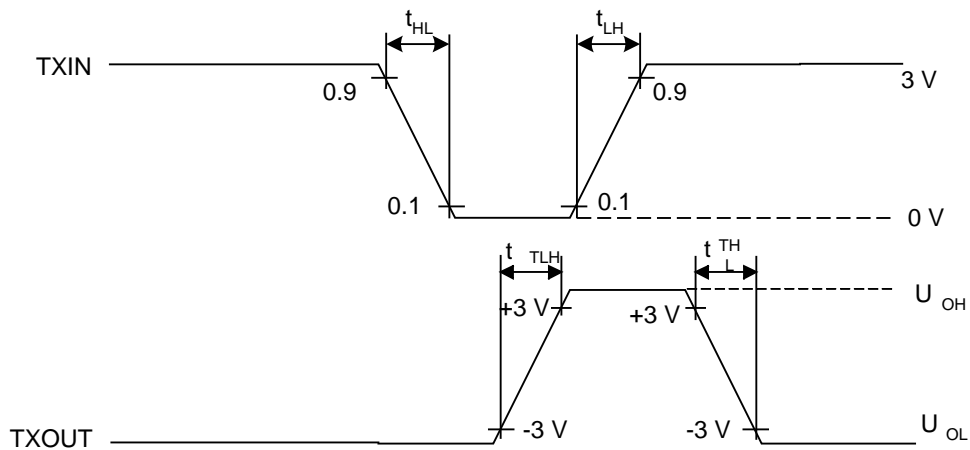

**Structural switch-on diagram of microcircuits in operation**

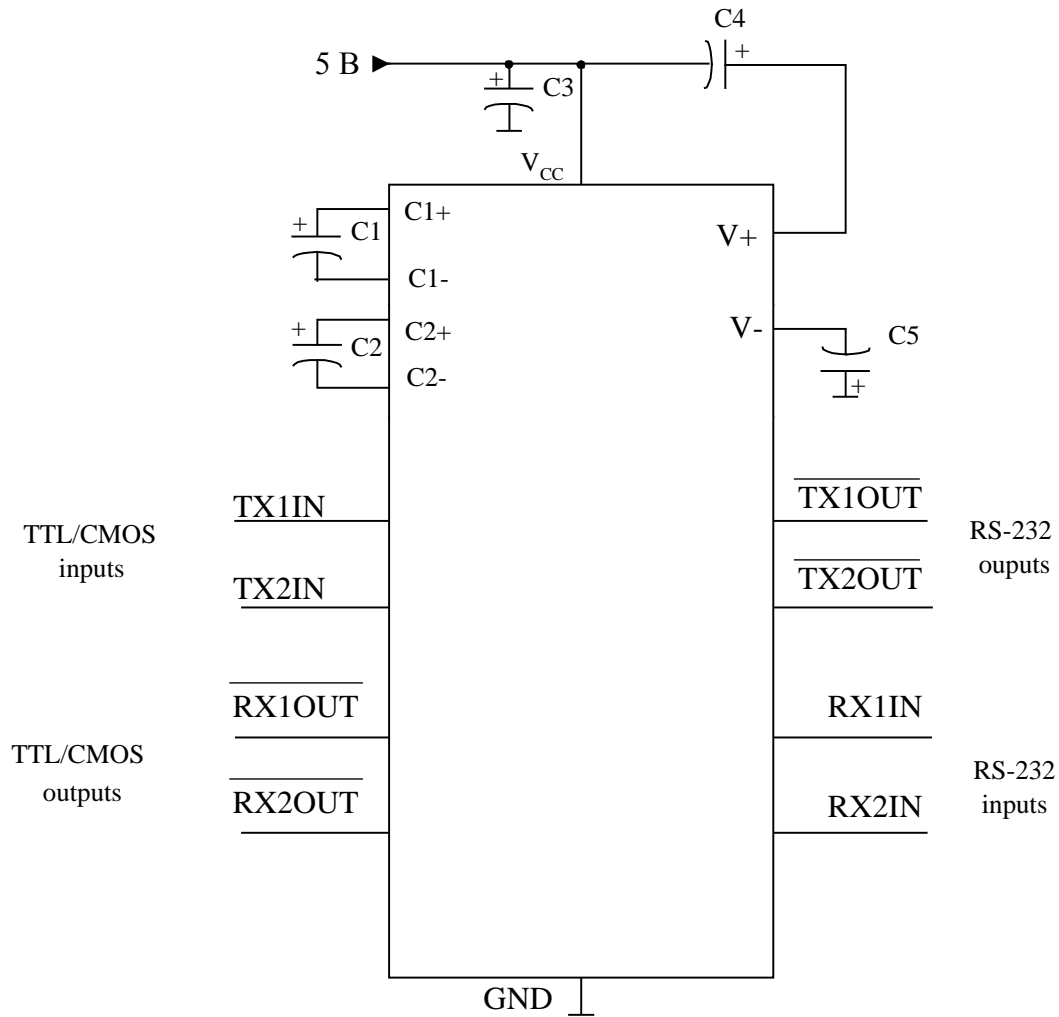

### Important statement:

Huaguan Semiconductor Co,Ltd. reserves the right to change the products and services provided without notice. Customers should obtain the latest relevant information before ordering, and verify the timeliness and accuracy of this information.

Customers are responsible for complying with safety standards and taking safety measures when using our products for system design and machine manufacturing to avoid potential risks that may result in personal injury or property damage.

Our products are not licensed for applications in life support, military, aerospace, etc., so we do not bear the consequences of the application of these products in these fields.

Our documentation is only permitted to be copied without any tampering with the content, so we do not accept any responsibility or liability for the altered documents.