

REVISIONS ÄNDERUNGEN					
P	LTR	DESCRIPTION BESCHREIBUNG	DATE	DWN	APVD
	C1	REVISED PER ECO-11-005150	21MAR111	RK	HMR
	D	REVISED PER PCN E-20-014128	05OCT2020	MK	GL

WAR NR. \_\_\_\_\_  
VERWENDET FÜR  
PASSEND ZU 967325,967326  
967402,967447

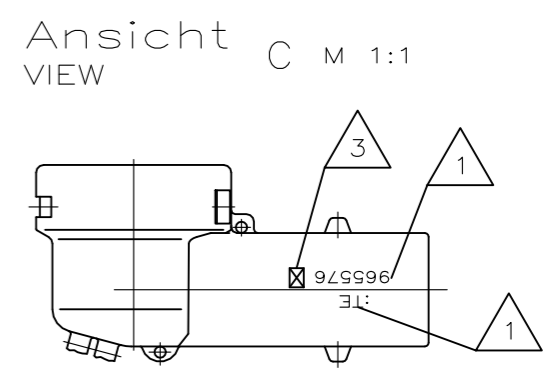

Darstellung der verrasteten Kappe  
ILLUSTRATION OF ASSEMBLED CAP  
M 1:1

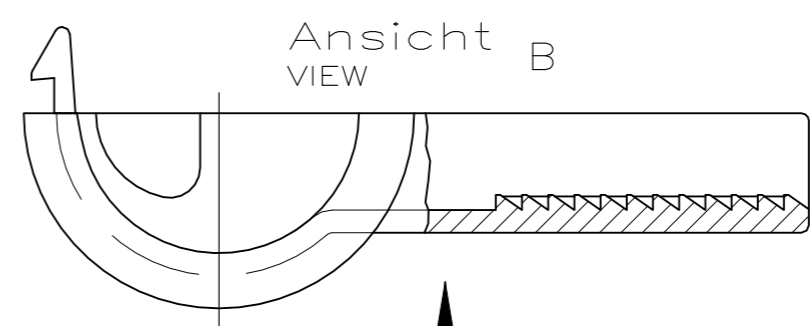
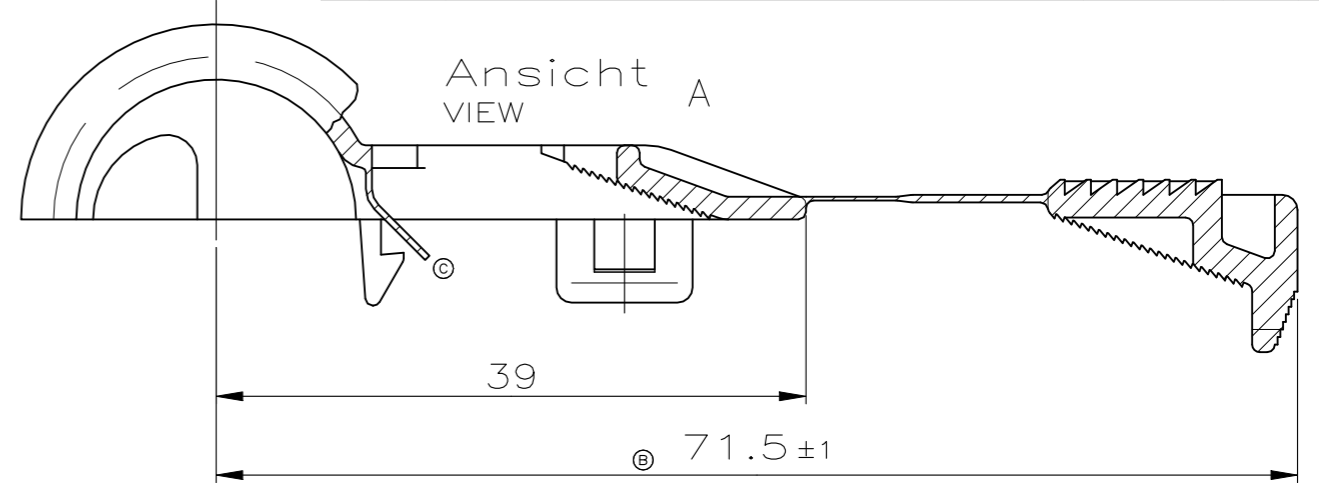
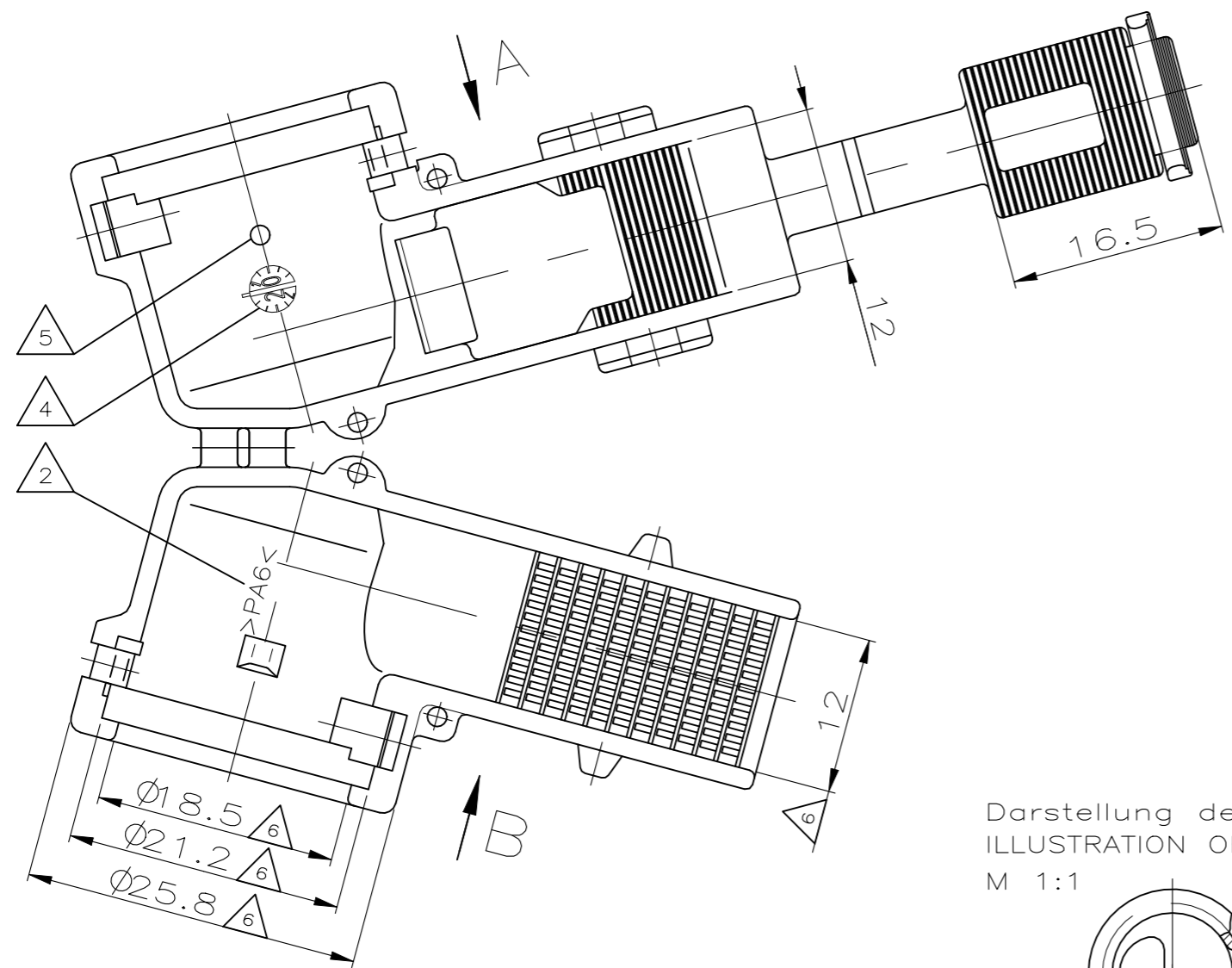
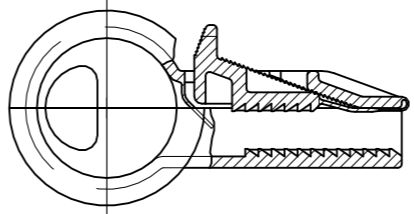

Bemerkungen  
NOTES

- 1 TE-Logo und TE-Nummer  
TE LOGO AND TE NUMBER
- 2 Werkstoffkennzeichnung  
MATERIAL MARKING
- 3 Werkzeugaenderungsindex  
REVISION OF THE MOULD
- 4 Produktionsdatum  
PRODUCTION DATE
- 5 Nestmarkierung  
CAVITY MARKING
- 6 Verzug vom Nennmaß bis  
-0.8mm zugelassen  
WARPAGE FROM NOM. DIMENSION  
UP TO -0.8MM ALLOWED

965576-1	-	-	Kappe 90° m. variabler Klemmung CAP 90° FOR VARIABLE FIXING	PA 6	schwarz/BLACK
Bestell-Nr. ORDER-NR.	POS.	Stück QTY	Benennung Einzelteil DESCRIPTION SINGLE PART	Werkstoff MATERIAL	Oberfläche/SURFACE Farbe/COLOUR

THIS DRAWING IS A CONTROLLED DOCUMENT. DIESE ZEICHNUNG IST EIN KONTROLLIERTES DOKUMENT.		DWN J.Granzow 07.06.95	<b>STE</b> TE Connectivity		
DIMENSIONS: MASSE/NEHTEN: mm		CHK J.Hass 08.06.95			
TOLERANCES UNLESS OTHERWISE SPECIFIED: ALLGEMEINTOLERANZEN		APVD -	NAME Kappe 90DEG mit variabler Klemmung CAP 90DEG FOR VARIABLE FIXING		
0 PLC ± - 1 PLC ± 0.4 2 PLC ± - 3 PLC ± - 4 PLC ± - ANGLES / WINKEL ± 2°		PRODUCT SPEC PRODUKTSPEZ. 108-18621 / 106-18622	SIZE A3		
MATERIAL -		APPLICATION SPEC VERARBEITUNGSSPEZ. 114-18255	CAGE CODE 00779	DRAWING NO ZEICHNUNGS-NR. G-965576	RESTRICTED TO NUR FUER -
FINISH/OBERFLAECHE/FARBE -		WEIGHT GEWICHT -	CUSTOMER DRAWING/KUNDENZEICHNUNG		
		SCALE MASSTAB 2:1	SHEET BLATT 1 von 1	REV D	