

# SPECIFICATION FOR APPROVAL

## 规格式样书

Seller 销售商	PowerNex
Manufacturer 制造商	CCHV
MODEL NO. 型号	CHA6012BH-15D

CUSTOMER APPROVAL 顾客确认 (请每页签名确认或加盖骑缝章, 若没有按此签名, 规格书确认无效)  
 DATE/Signature 日期及签章

Rev. 版本	Date 日期	Description 描述
00	2022/7/01	新版发行

Notice:备注

This offer is made according to your current inquiry. Unless otherwise revised, this specification will be final for all future production

of orders from your company. 此式样书基于当前的贵司的需求, 此式样书作为贵司认可之最终量产之规格除非有更新。

Kindly study in detail and send back to us the specification sheets with your confirmation signature in order to make an

arrangement for production. 请仔细确认并签回本式样书作为生产之依据。

# 肇庆晟辉电子科技有限公司

## Zhaoqing Shenghui Electronic technology co.,LTD

Approved 签核	Checked by 确认	Authorized by 设计
周金华	严世昌/杜冠机	李超

## PRODUCT SAFETY 产品安全

1. CCHV will not guarantee this product if it is used in conditions other than the parameters outlined in this specifications. 我们不保证超规格使用的产品可靠性。
2. Please contact CCHV to confirm any customer requirements not specified in the specification. 当您的需要未在本式样书中定义请联络我们。
3. Please handle fans carefully. Damage may result from pressure to the impeller, carrying by the lead wires, or dropping fans on a hard surface. 请仔细处置风扇. 当有外力压扇叶, 拉扯线缆, 或者风机掉落在硬质地面时有可能造成风机的损伤。
4. The introduction of power, dust water insects or other erosion elements into the HUB will result in safety problems or product failure, except in products designed for special environments. 将电源、尘、水、昆虫或其他侵蚀元素引入轮毂将导致安全问题或产品故障, 但为特殊环境设计的产品除外。
5. Items 1-4, mentioned above, are generally pertinent to our products, and should be a first point of reference. 上述第 1-4 项通常与我们的产品有关, 应作为第一参考要点。
6. It is very important to establish the correct polarity before connecting the fan to the power source, Positive (+) and Negative (-). Damage may be cause by connecting with reverse polarity. 在将风扇连接到电源正极 (+) 和负极 (-) 之前, 确认正确的极性非常重要。反接可能导致损坏。
7. Avoid operating our products in environments where poisonous or corrosive elements are present (organic, silicon, cyanogens, formal in phenol, H<sub>2</sub>S, SO<sub>2</sub>, NO<sub>2</sub>, Cl<sub>2</sub>, etc) 避免在有毒或腐蚀性元素存在的环境中操作我们的产品 (有机物、硅、氰化物、苯酚中的甲醛、硫化氢、二氧化硫、二氧化氮、二氧化氯等)
8. Please ensure that fans are stored according to the storage temperature specified. Do not store in a high humidity environment. If fans are stored for more than 6 months, CCHV recommends testing of fans before using. 请确保风扇被按照规定的存储温度存储。不要存放在高湿度环境中。如果风机存放时间超过6个月, CCHV 建议在使用前对风机进行测试。
9. Not all series fans are provided with the lock rotor protection feature. Damage or failure will result from operating fans without this feature, if the impeller for the fan is in any way hindered or impaired. 并非所有系列风扇都具有锁定转子保护之功能。如果风扇的转子以任何方式受到阻碍或损坏, 没有此功能的风扇将被之损坏或引发故障。
10. Install fans carefully. Incorrect mounting or installation may result in excessive resonance, vibration and subsequent noise. 小心地安装风扇。不正确地安装可能导致共振、振动和引起的噪音。
11. Safety is a top priority. Please utilize guard accessories to prevent injury to personnel. 安全是最高的要务。请使用防护配件以防止人员受伤。
12. Unless otherwise noted, all tests are conducted at 25° C ambient temperature, and 65% relative humidity. 除非另有说明, 所有试验均在25° C环境温度和65%相对湿度下进行。
13. When using multiple fans in parallel, connect an 'over 4.7 μF' capacitor externally to the fan to prevent abnormal resulting from unstable power. 当并联使用多个风扇时, 在风扇外部连接一个“>4.7 μf”的电容器, 以防止输入不稳定而导致异常。
14. Any change to the parameters specified in this specification will be determined by mutual agreement between both parties. Parameters not specified will be identical to the final sample approved by your company. 本规格式样书中规定的参数的任何变更将由双方协商决定。未指定的参数将与贵公司批准的最终样品相同。

## 2.1 Electrical Characters 电子特性:

No. 编号	Item 项目	Specification 规格式样	Remark 备注
2-1	Rated Voltage 额定电压	D.C. 直流 12.0V	
2-2	Operating voltage 操作电压范围	D.C. 直流 6.0V~13.2V	
2-3	Starting voltage 启动电压	D.C. 直流 6.0V	At 25°C Power ON/OFF in free air 在自由流场中 25°C电源开关启动
2-4	Operating Current 操作电流	0.17( Max. 0.26)A	Free Air at Rated voltage 在自由流场中输入额定电压
2-5	Current on label 标签上电流	0.30A	
2-6	Power 功率	2.04( Max. 3.12)W	
2-7	Operating temperature and humidity range 操作温度和湿度	-10°C to 70°C, 5% to 90% RH	
2-8	Storage temperature and humidity range 储存温度和湿度	-40°C to 70°C, 5% to 95% RH	

## 2.2 Mechanical Characters 机械特性

No. 编号	Item 项目	Specification 规格式样	Remark 备注
2-9	Bearing System 轴承系统	Ball Bearing 滚珠轴承	
2-10	Motor Design 马达设计	Single Phase 4 Poles Brush-less DC Motor 单相4极直流无刷马达	

### 2.3 Performance Characters 性能特性

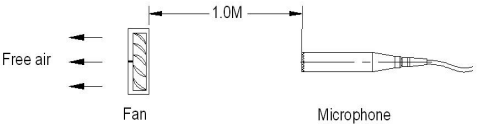
No. 编号	Item 项目	Specification 规格式样	Remark 备注
2-11	Speed速度	5,000±10%rpm	At 25°C, To record speed after fan running normal, This time about 3~5minutes 在 25°C 通电记录转速直至转速稳定, 这个时间大约需要 3~5 分钟
2-12	Air flow 风量	22.39CFM Min:20.15CFM	At zero static pressure 在 0 静压情况下
2-13	Air pressure 风压	5.74mmH <sub>2</sub> O Min:4.65mmH <sub>2</sub> O	At zero air flow 在 0 风量情况下
2-14	Acoustical noise 声音水平	36.85dB-A (Max:40.54) dB-A 1.0 meter from Air intake side 麦克风置于离入风口1米远处(如右图) Background noise max. 10.0dB-A 无响室 本底噪声水平最大10.0dB-A	According to ISO10302 依据 ISO10302 Free Air at Rated voltage 在自由流场中输入额定电压 
2-15	Insulation Class 绝缘等级	UL: Class A	
2-16	Insulation resistance 绝缘阻抗	Min 10Meg Ohm 阻抗>=10Meg Ohm	between frame and lead wire (+) at 500VDC 在扇框和线材的“+”之间输入 500VDC
2-17	Dielectric strength 绝缘强度	500VAC 60Hz 1 second 交流500V 60赫兹1秒	5mA max at between frame and lead wire 最大 5mA 扇框 和线材的“+”之间
2-18	Life expectancy 期望寿命	L10>=50,000hrs continuous at 40°C L10>=50,000小时持续动作40°C	
2-19	Ingress Protection 防护等级		Stator moisture-proof 定子防潮
2-20	Automatic Restart 自动重启	Yes	
2-21	Reverse connection Protection 反接保护	Yes	

### 3. PQ curve: (Rated Voltage) PQ 曲线(输入额定电压)

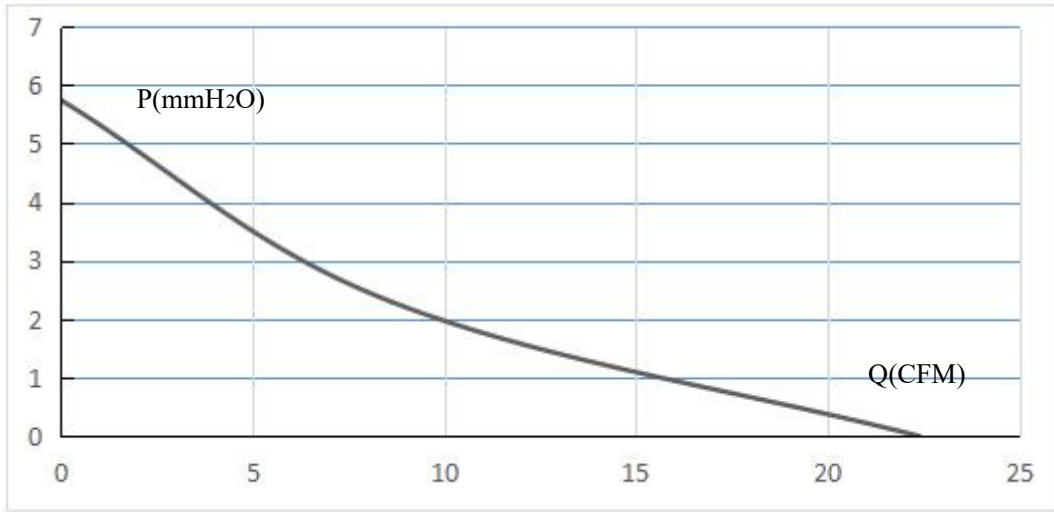

### 4. Reliability Test 可靠性试验

#### 4.1 Drop test: 跌落测试

Fans are packed in a standard shipping size box and dropped to the wooden board from certain heights and angles depending on the weight of particular box 采用标准的运输包装依据其重量采取标准规定的高度及角度跌落在木制底板上。

#### 4.2 Impeller Lock Test: (IEC 60950)

1. Test temperature 测试温度	under 25 °C or room temperature 25 °C 或者室温
2. Input rated voltage 输入电压	Maximum operating voltage 最大操作电压
3. Coil temperature 线圈温度	< 150 °C
4. Duration 时间	72 hours 72 小时
5. After lock testing 结束测试	Perform 500VAC / 60sec dielectric strength test 输入 500VAC/ 60sec 测试其绝缘强度

#### 4.3 High Temperature & High Humidity / On/Off Test 高温高湿通断电测试: (IEC 60068-2-2)

1. Test condition 测试条件	Maximum operating voltage & maximum operating temperature & Maximum operating humidity 输入最大操作电压和最高操作温度和最高操作湿度
2. Power On / Off Profile 操作曲线	
3. Total cycle 总循环数	48 cycles for 72 hours 48 个循环持续 72 小时

#### 4.4 Thermal shock: (IEC 60068-2-14)

1. Low Temperature 低温	-40 °C/15min
2. High Temperature 高温	+75 °C/15min
3. Transition time 转换时间	less than 5 minutes 小于 5 分钟
4. Number of cycle 测试循环数	20

#### 4.5 RoHS compliance: RoHS 保证

see RoHS standard 请查看 RoHS 标准

#### 4.6 Life expectancy: 寿命期望

The “Life expectancy” of CCHV fans is determined in CCHV’ s laboratory of reliability test by using temperature chamber with high acceleration life time test method. Therefor the life expectancy “L10 report” based on calculation according to ALT. 对于我们的产品的”寿命期望”是基于我司的可靠性测试关于使用高加速寿命试验的方法得出的由我司实验室进行的测试完成。因此该寿命期望《L10 Report》依据 ALT 方法计算而得。

ALT 方法计算公式:  $t = 1.036 \times \text{MTTF} \times [(Br;c) \div n]^{0.91} \div AF$  , and  $AF = 2(Ts - Tu) / 10$

Ts 为测试温度

Tu 为要计算 L10 的温度

MTTF=L10×7

(Br;c)=0.9

n 为测试样品数量

t 为需要测试的时间

#### 5. Label: 标签 (标签直径 φ 28mm)



## 6. Drawing 图纸 (单位: mm)

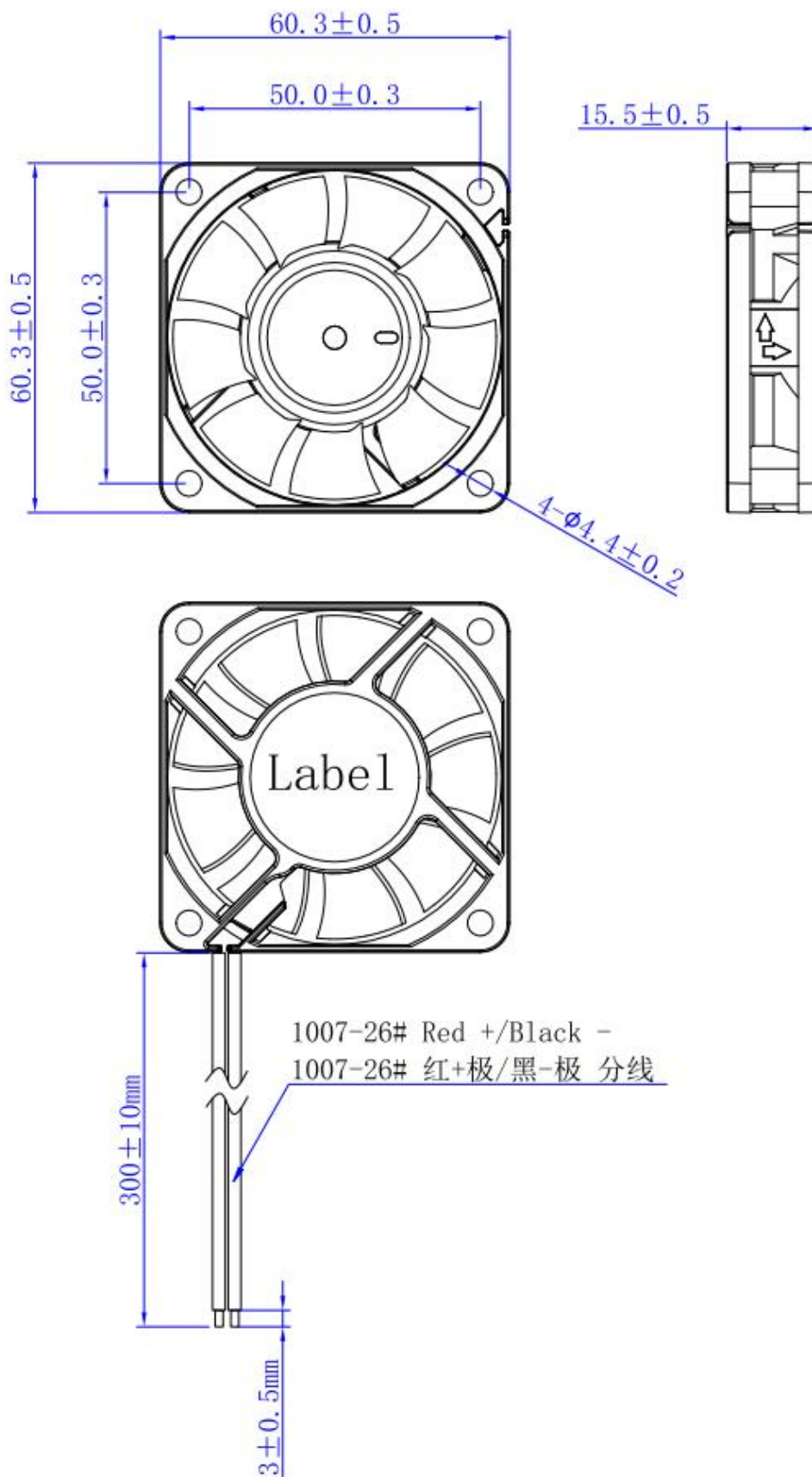



## 7. 产品包装说明:

版本	记录	修订说明	修改人	日期
00		仅供参考	李婉虹	2022-07-01

每个盒子1Pcs产品

共240Pcs产品

每箱放两块纸板，上下各一块

\*38.6 ± 0.5 cm

\*43.0 ± 0.5 cm

\*26.9 ± 0.5 cm

注:

1. 图中尺寸, 公差为<sup>+30</sup><sub>-10</sub>mm;
2. 纸箱两边侧唛右上角都要以80\*80mm方框标出贴标位;
3. 纸箱的正唛、侧唛排版布局要美观;
4. 纸箱各面平整, 无破损;

6015包装规范		材质	A=B加坑110			
批准	签名	重量	料号			
校对		视角		角度	X.X	X.XX
设计		单位		一般公差	±1°	±0.1