

### TIN-VERSION

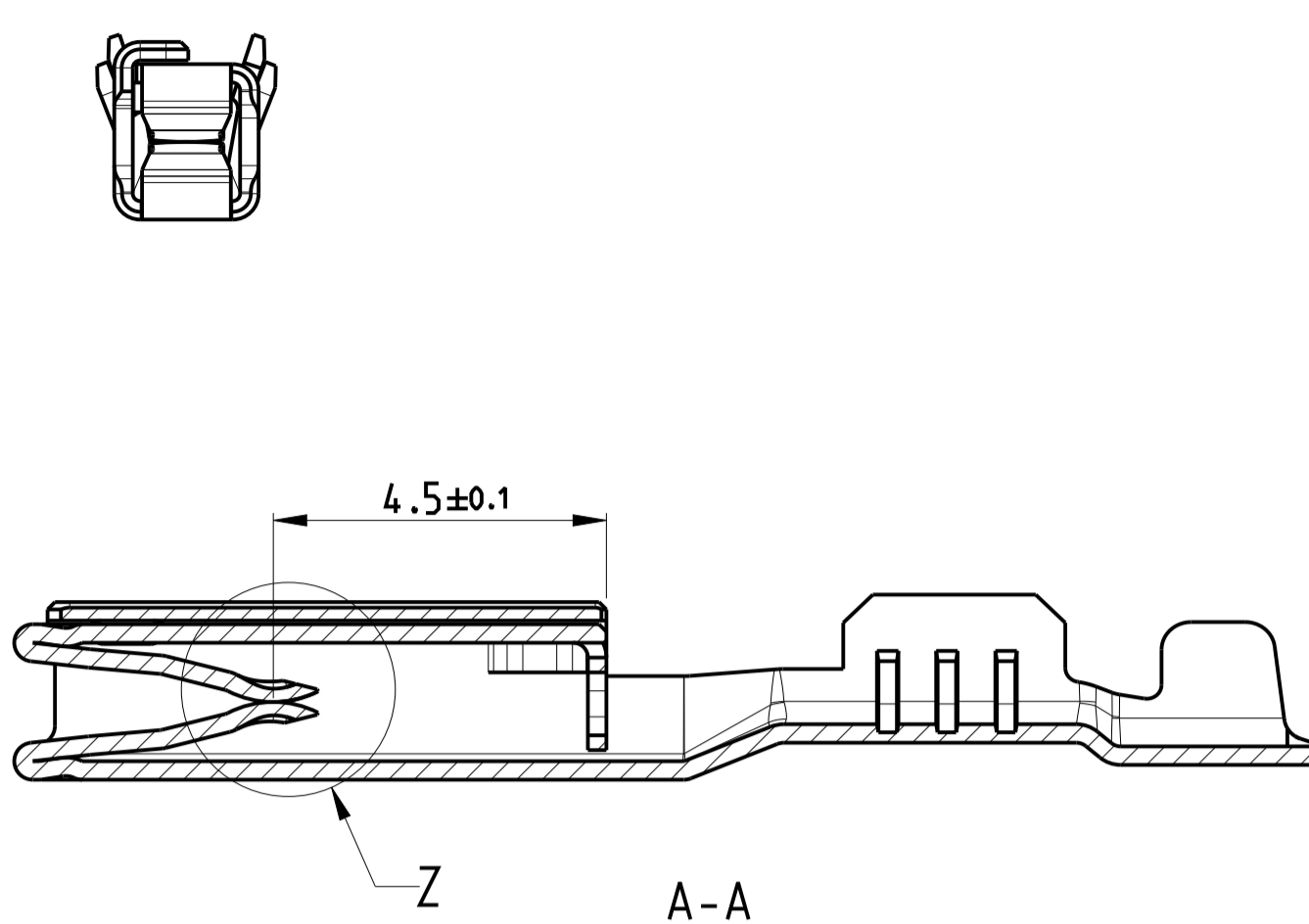

### SILVER-VERSION

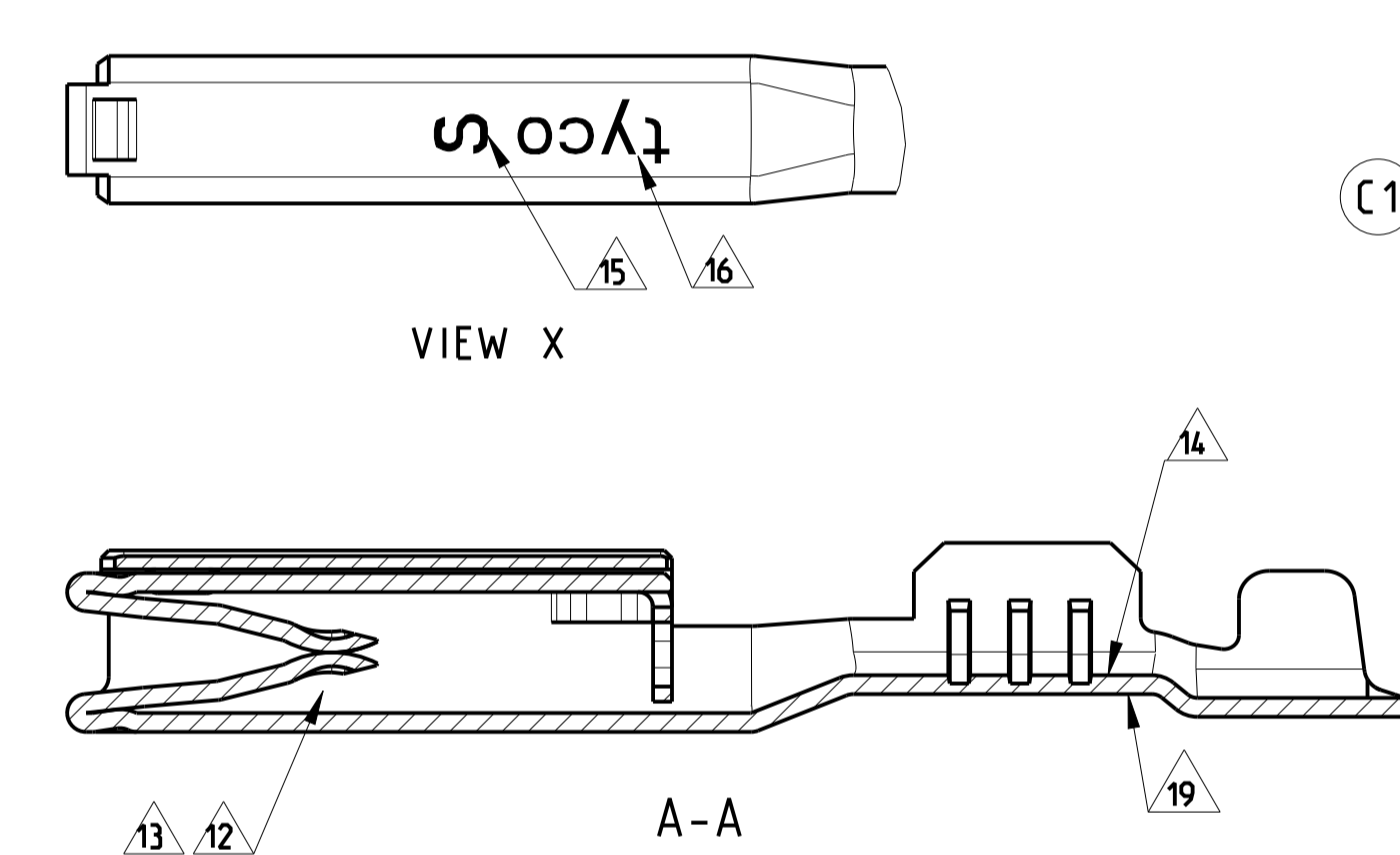

### GOLD-VERSION

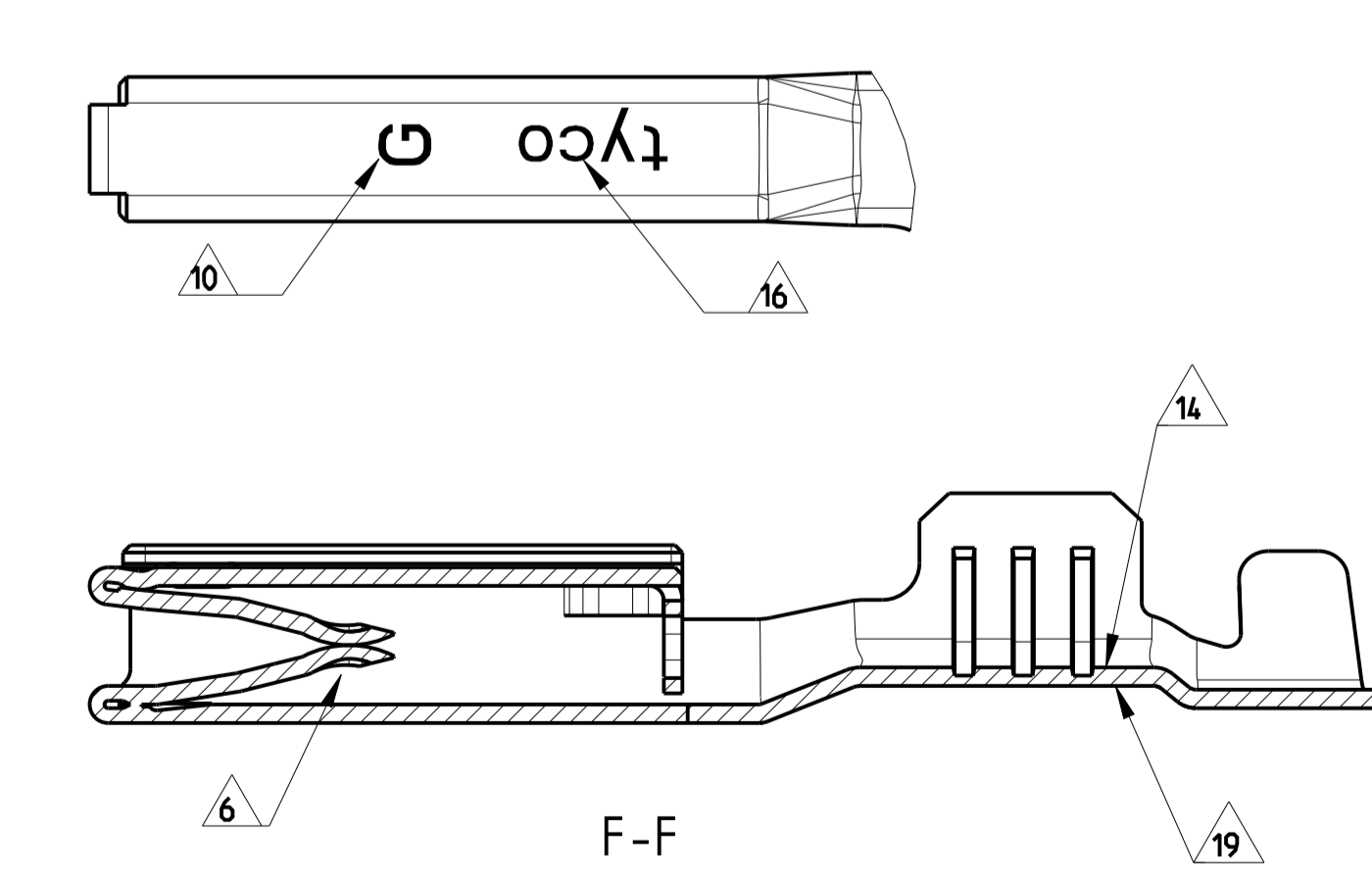

REVISIONS				
P	LTR	DESCRIPTION	DATE	APPD
C		SEE ECR-14-012287	01SEP2014	SS GS
C1		ECR-15-010934	23JUL2015	SS GS
D		REV PER ECO-20-007097	14OCT2020	GTG WW
D1		REV PER ECO-21-002916	08MAR2021	RGV WW

- NOTES:**
- MATERIAL: COPPER ALLOY. MATERIAL THICKNESS 1-0.25±0.01
  - MUST BE FREE OF CRACKS AND BURRS THAT AFFECT FUNCTIONS.
  - WHEN A TIN/GOLD PLATED TERMINAL IS USED ON THE MALE SIDE THEN THE CORRESPONDING PLATING (TIN OR GOLD) MUST BE USED ON THE FEMALE TERMINAL.
  - NICKEL UNDERPLATE 0.1µm MIN. UNLESS OTHERWISE NOTED.
  - 0.2 mm MAX RADIUS PERMISSIBLE ON EDGES AND FILLETS SHOWN AS SHARP FOR STAMPING PARTS.
  - GOLD PLATING 0.76µm MIN. OVER NICKEL 1.8µm MIN. (CONTACT AREA ONLY).
  - LUBRICATION: OPTIMOL
  - THE WIDTH OF THE TRANSITION (INDICATED AREA) MAY NOT EXCEED 2.0MM
  - TE CONNECTIVITY-CRIMP SPECIFICATION: 114-13060
  - "G" MARKING TO IDENTIFY Au VERSION
  - GOLD PLATING (±0.38µm Au) FOR GOLD SHORTING BAR APPLICATIONS VALID FOR 1393366-2 AND 1393365-2 ONLY
  - SILVER PLATING 3-5µm OVER NICKEL 0.5µm MIN. (CONTACT AREA ONLY)
  - TARNISH FOR SILVER VERSION
  - TIN PLATING 2-4µm OVER NICKEL (CRIMP AREA ONLY)
  - SILVER MARKING
  - ALTERNATE LOGO "TE" OR "1" IS ALLOWED
  - OPTIONAL NOTCH DESIGN ALLOWED
  - FOR SILVER PLATING: ELECTRICAL PERFORMANCE IS NOT AFFECTED BY GRAY OR BLACK TARNISH ON THE SILVER PLATING SURFACE. ACCEPTABLE SILVER SURFACE CAN INCLUDE GRAY OR BLACK TARNISH.
  - TIN PLATING 0.6µm MIN. OVER NICKEL (CRIMP AREA ONLY)
  - SILVER PLATING (±0.5µm Ag) FOR SILVER SHORTING BAR APPLICATIONS. VALID FOR 1393366-2 AND 1393367-2 ONLY.
  - DEM REQUIRED PART NUMBER FOR TRACEABILITY. THIS PART NUMBER IS SAME AS P/N 0-1393367-2.
  - DEM REQUIRED PART NUMBER FOR TRACEABILITY. THIS PART NUMBER IS SAME AS P/N 0-1393366-2.
  - PRE-PLATED TIN 2-4µm ALL OVER.

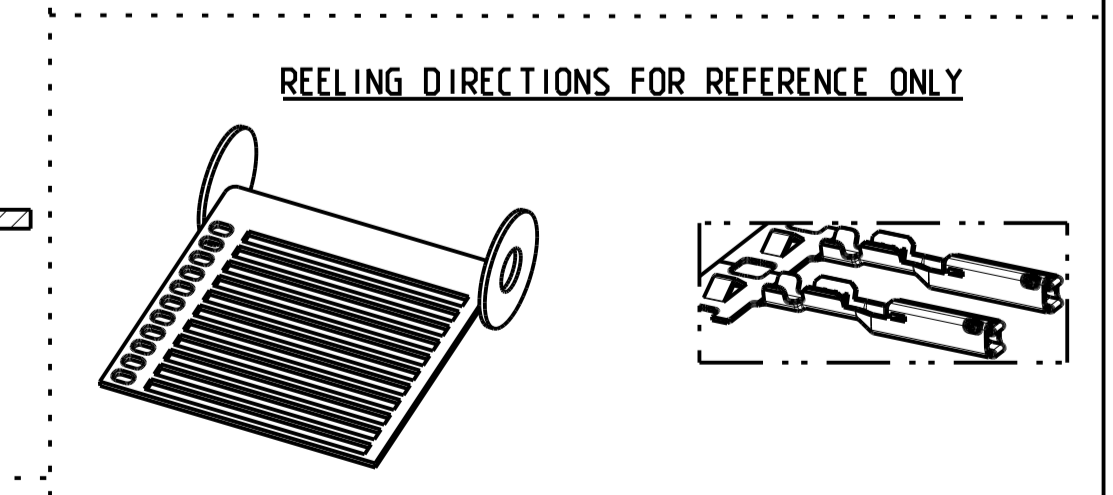
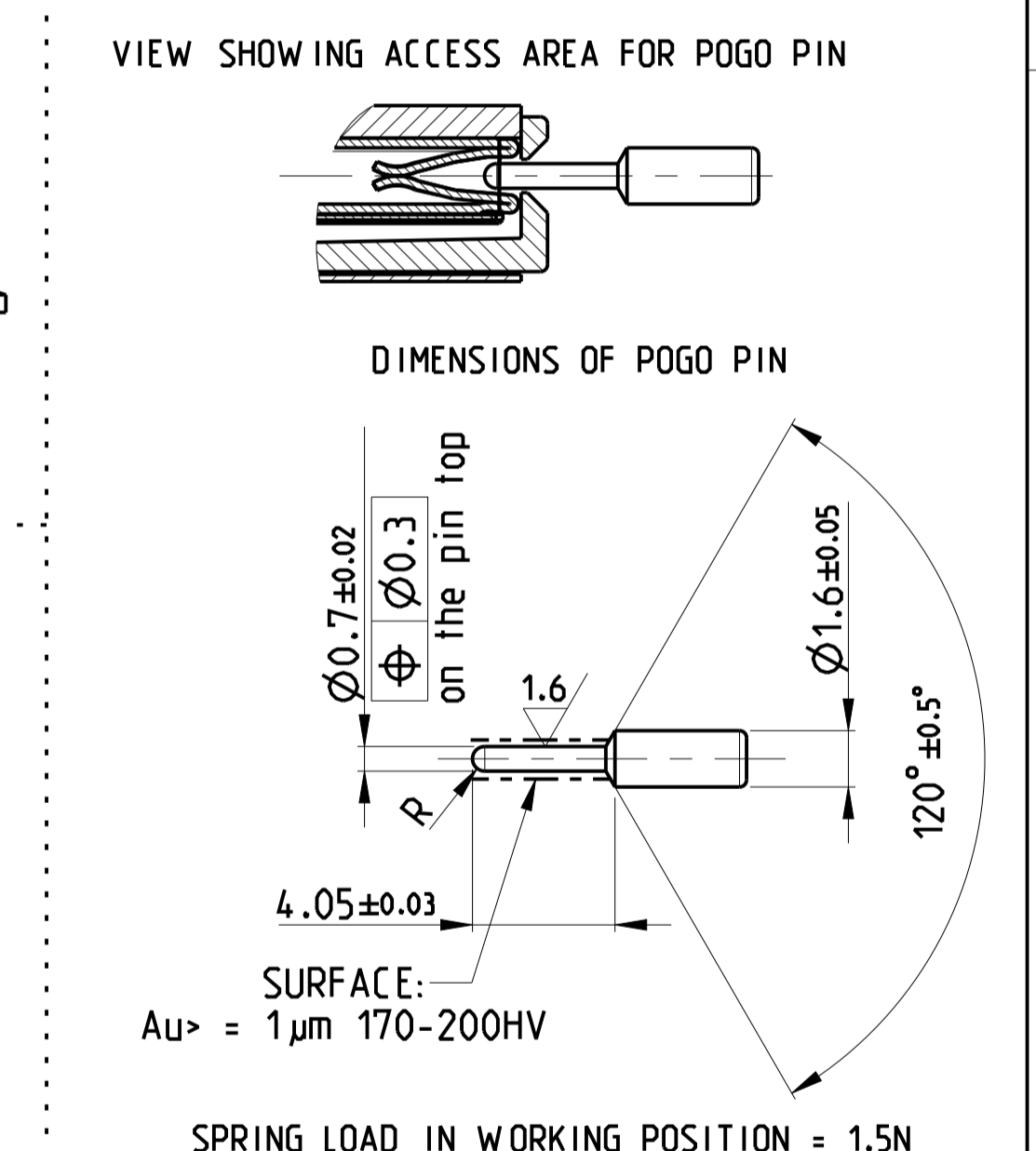

TABLE 1: TERMINAL CRIMP & GRIP REFERENCE TABLE.

PART NO.	PART-REV.	PLATING SPECIFICATION	WEIGHT	CONDUCTOR WIRE SIZE	DIMENSIONS					CONDUCTOR CRIMP INFO	INSULATION CRIMP INFO	MATERIAL TYPE
					A1	A2	R1	R2	GRIP SIZE			
0-1393364-1		GOLD PLATING	0.22g	0.22	2.11	2.4	0.45	0.6	A	SEE TE Connectivity SPEC 114-13060	CuNi35SiMg DIN 1777	
0-1393364-2	B	GOLD PLATING		0.35	2.11	2.4	0.45	0.6	A			
0-1393367-2		SILVER PLATING	0.22g	0.22	2.11	2.4	0.45	0.6	A	SEE TE Connectivity SPEC 114-13060	CuNi35SiMg DIN 1777	
2-1393367-2	B	SILVER PLATING		0.35	2.11	2.4	0.45	0.6	A			
0-1393367-1	B	TIN PLATING	0.22g	0.22	2.11	2.4	0.45	0.6	A	SEE TE Connectivity SPEC 114-13060	CuNi35SiMg DIN 1777	
0-1393365-1	B	TIN PLATING		0.35	2.11	2.4	0.45	0.6	A			
0-1393365-1		GOLD PLATING	0.22g	0.50	2.8	3.1	0.6	0.2	B	SEE TE Connectivity SPEC 114-13060	CuNi35SiMg DIN 1777	
0-1393365-2	B	GOLD PLATING		0.75	2.8	3.1	0.6	0.2	B			
0-1393366-2		SILVER PLATING	0.22g	0.50	2.8	3.1	0.6	0.2	B	SEE TE Connectivity SPEC 114-13060	CuNi35SiMg DIN 1777	
2-1393366-2	B	SILVER PLATING		0.75	2.8	3.1	0.6	0.2	B			
0-1393366-1	B	TIN PLATING	0.22g	0.50	2.8	3.1	0.6	0.2	B	SEE TE Connectivity SPEC 114-13060	CuNi35SiMg DIN 1777	
0-1393366-1	B	TIN PLATING		0.75	2.8	3.1	0.6	0.2	B			

THIS DRAWING IS A CONTROLLED DOCUMENT.

TE Connectivity logo and product information: GET FEMALE TERMINAL, GET BUCHSEN KONTAKT.

Part number: 00779, C=1393364

Scale: 10:1, Sheet 1 of 1, Rev 01