

Customer Information Sheet

DRAWING No.: M80-851XXXX

SHEET 2 OF 2

IF IN DOUBT - ASK

(C)

NOT TO SCALE

THIRD ANGLE PROJECTION

ALL DIMENSIONS IN mm

ORDER CODE:

M80-851XXXX

TOTAL No. OF WAYS

04, 06, 08, 10, 12, 14, 16,
18, 20, 26, 34, 44

FINISH:

42 = SELECTIVE GOLD + 100% TIN
45 = GOLD

NOTES:

- 2-OFF STRAIN RELIEF STRAP M80-0030006 ARE INCLUDED WITH EACH CONNECTOR.

SPECIFICATIONS:

MATERIAL:

MOULDING = POLYAMIDE 46 UL94V-0, BLACK
CONTACTS = PHOSPHOR BRONZE
LATCHES = BERYLLIUM COPPER

FINISH:

CONTACTS:

42 = 0.75µ GOLD ON CONTACT AREA,
3.0µ 100% TIN ON TAILS
45 = 0.75µ GOLD

LATCH = 1.25µ NICKEL

ELECTRICAL:

CURRENT RATING (25°C) = 3.0A MAX.
CURRENT RATING (85°C) = 2.2A MAX.
WORKING VOLTAGE = 120V AC/DC
VOLTAGE PROOF = 360V AC/DC
CONTACT RESISTANCE (INITIAL) = 20 mΩ MAX.
CONTACT RESISTANCE (AFTER CONDITIONING) = 25 mΩ MAX.
INSULATION RESISTANCE (INITIAL) = 1000 MΩ MIN.
INSULATION RESISTANCE (AFTER CONDITIONING) = 100 MΩ MIN.

MECHANICAL:

DURABILITY = 500 OPERATIONS

ENVIRONMENTAL:

TEMPERATURE RANGE = -55°C TO +125°C

PACKING:

TUBE

FOR COMPLETE SPECIFICATION, SEE COMPONENT SPECIFICATION C005XX (LATEST ISSUE)

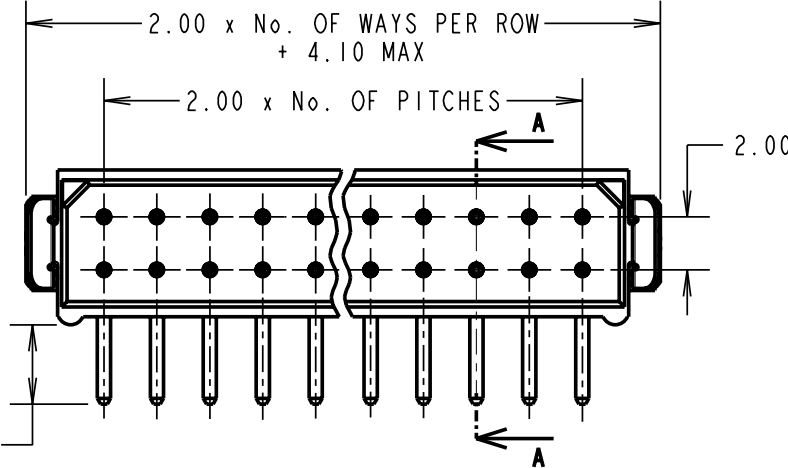

SECTION A-A

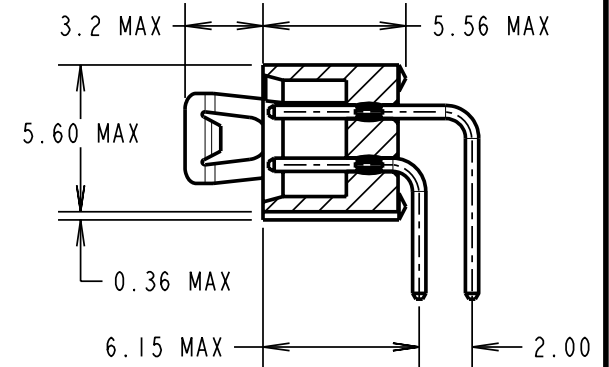

(3.0)

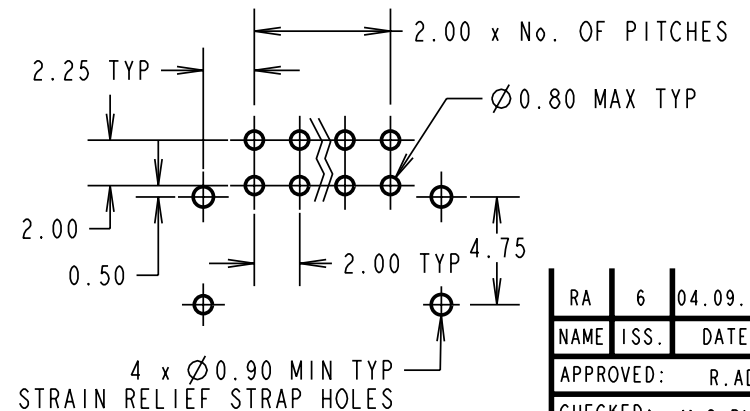
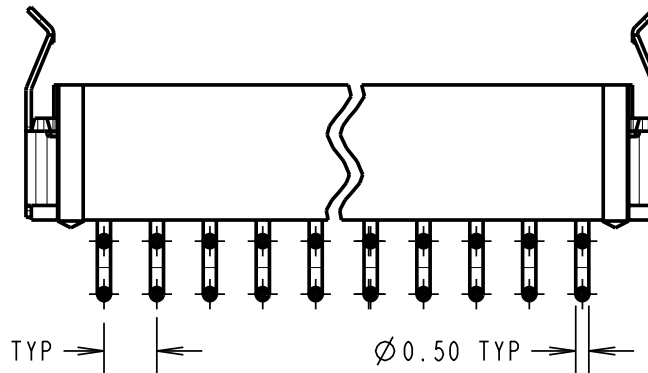

RECOMMENDED PCB LAYOUT

RA	6	04.09.08	10127
NAME	ISS.	DATE	C/NOTE
APPROVED:		R. ADDE	
CHECKED:		M.G. PLESTED	
DRAWN:		I. SANDY	
CUSTOMER REF.:			
ASSEMBLY DRG:			

HARWIN

HARWIN USA
TEL: 603 893 5376
FAX: 603 893 5396
mis@harwin.com

HARWIN Europe (UK)
TEL: 023 9231 4545
FAX: 023 9231 4590
mis@harwin.co.uk

HARWIN Asia
TEL: +65 6 779 4909
FAX: +65 6 779 3868
mis@harwin.com.sg

THIS DRAWING AND ANY INFORMATION OR DESCRIPTIVE MATTER SET OUT HEREON ARE CONFIDENTIAL AND COPYRIGHT PROPERTY OF THE HARWIN GROUP AND MUST NOT BE DISCLOSED, LOANED, COPIED OR USED FOR MANUFACTURING, TENDERING OR FOR ANY OTHER PURPOSE WITHOUT THEIR WRITTEN PERMISSION.

TOLERANCES
X. = ±1mm
X.X = ±0.25mm
X.XX = ±0.10mm
X.XXX = ±0.01mm
ANGLES = ±5°
UNLESS STATED

MATERIAL:

SEE ABOVE

FINISH: SEE ABOVE

S/AREA: mm²

TITLE: DATAMATE DIL
HORIZONTAL 90° TAIL PLUG
ASSEMBLY - LATCHED (RoHS)

DRAWING NUMBER:

M80-851XXXX

SHT
2 OF 2