

Overview

CH579 is an ARM 32-bit microcontroller that integrates BLE wireless communication. The chip has integrated rich peripheral resources such as Bluetooth Low Energy (BLE) communication module, Ethernet controller and transceiver, full-speed USB host/device controller and transceiver, segment LCD driver module, ADC, TouchKey detection module and RTC, etc.

Features

- **Core:**

- ARM 32-bit Cortex-M0 core
- 40MHz maximum frequency, 32KHz minimum frequency

- **257K bytes non-volatile memory FlashROM:**

- 250KB user application memory area, CodeFlash
- 2KB user non-volatile data memory area, DataFlash
- 4KB system bootloader program memory area, BootLoader
- 1KB system non-volatile configuration information memory area, InfoFlash
- Support ICP, ISP and IAP, support OTA wireless upgrade

- **32K bytes volatile data storage SRAM:**

- 16KB memory area only supplied by the main power source, RAM16K
- 14KB sleep retention memory area supplied by two power sources, RAM14K
- 2KB sleep retention memory area supplied by two power sources, RAM2K

- **Power supply management and low-power consumption:**

- Support 3.3V and 2.5V power supply; a range between 2.2V and 3.6V
- Built-in DC-DC conversion, 6mA current when transmitting power at 0dBm
- Idle mode: 1.2mA
- Halt mode: 420uA
- Sleep mode: 0.6uA~2.6uA, multi-gear
- Shutdown mode: 0.2uA~1.5uA, multi-gear
- Low-voltage monitoring of battery voltage

- **Security features:** AES-128 encryption and decryption, unique chip ID

- **Bluetooth Low Energy (BLE):**

- Integrated 2.4GHz RF transceiver, baseband and link control
- Single-ended RF interface, no external inductor required, simplified board design
- Receive sensitivity of -93dBm, programmable+3dBm transmit power
- BLE is compliant with the specification of Bluetooth Low Energy 4.2
- Wireless communication distance is about 100m at 0dBm transmit power
- Optional PCB on board antenna in various shapes and sizes

- Provide optimized protocol stack and application layer API, support networking

- **Ethernet:**

- Built-in MAC controller with DMA support
- Integrated 10Mbps transceiver PHY, built-in 50Ω matching resistor
- Communication distance 200 m, support Auto-Negotiation, support energy saving

- **Universal Serial Bus (USB):**

- Built-in USB controller and DMA, support 64-byte data packet
- Integrated USB 2.0 full-speed transceiver PHY, no peripherals required
- Support full/low-speed Host and Device modes
- Support USB type-C master/slave current detection

- **Real-time clock (RTC):** Support two modes: timing and trigger

- **Segment LCD:** Support 96-point (24×4) LCD panel

- **Analog to digital conversion (ADC):**

- 12-bit analog-to-digital converter, support differential and single-ended inputs
- 14 external analog signal channels and 2-channel internal signals

- **TouchKey detection module:** 14 channels

- **Timer and pulse width modulation (PWM):**

- 4 groups of 26-bit timers, 16MHz main frequency, timing up to 4.2S
- 4 channels of capture / sampling, support for rising / falling / both sides
- 4 channels of 26-bit PWM output, 8 channels of 8-bit PWM output

- **Universal Asynchronous Receiver/Transmitter (UART):**

- 4 groups of independent UARTs, compatible with 16C550, built-in 8-level FIFO
- 23-bit counter, up to maximum baud rate of 5Mbps
- UART0 supports Modem and hardware automatic flow control
- UART0 supports slave address matching automatically while communicating with multi-machine.

- **Serial Peripheral Interface (SPI):**

- 2 groups of independent SPIs, built-in FIFO
- The frequency of SCK serial clock is up to half of the system's main frequency

- SPI0 supports the modes of Master and Slave, supports DMA

- **LED dot matrix interface:** Support 1/2/4-channel data line
- **Clock:** Built-in 32MHz and 32KHz clocks, built-in PLL

- **8-bit passive parallel port**

- **Temperature sensor (TS)**

- **General Purpose Input/Output (GPIO):**

- 40 GPIOs, 4 of which support 5V signal input

- 32 interrupt inputs, 32 wake-up inputs

- **Package form:** QFN48_5×5, QFN28_4×4

Chapter 1 Pin Information

1.1 Pin arrangement

Figure 1-1 Pin configuration of CH579M (QFN48_5X5) and CH579F (QFN28_4X4) package

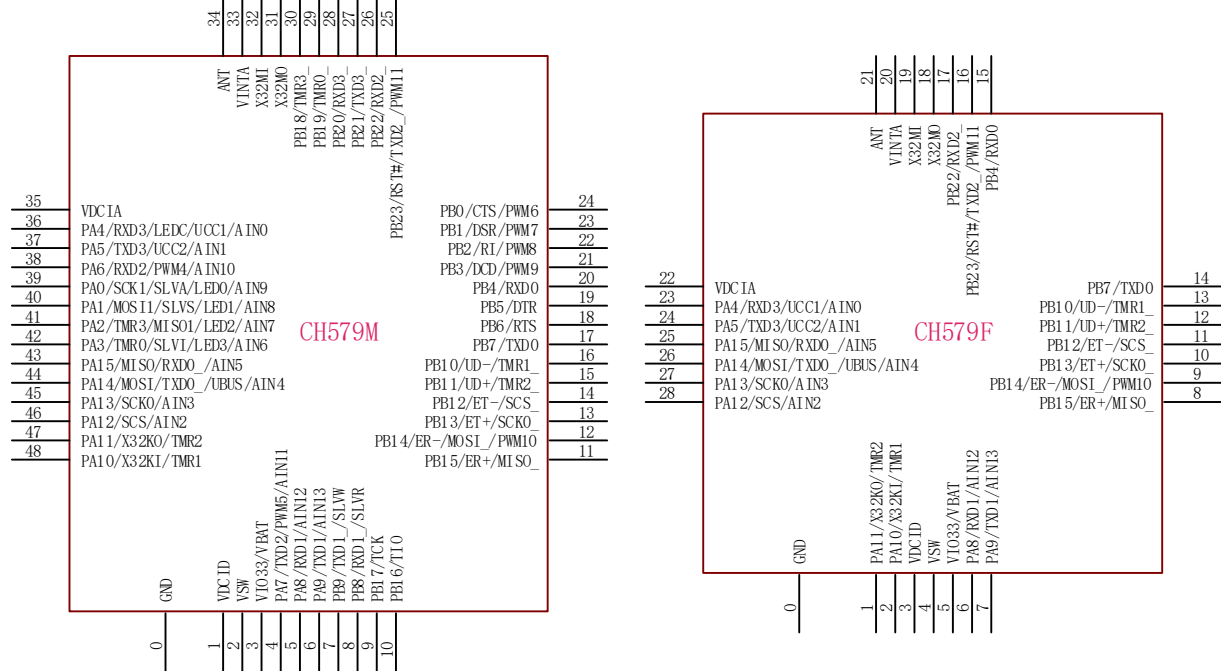

1.2 Pin definitions

QFN48 Pin No.	QFN28 Pin No.	Pin name	Pin type	Multiplexing feature prioritized	Function description
0	0	GND	Power	-	Common ground, the reference point of voltage is 0V.
1	3	VDCID	Power	-	Power input of the internal digital circuit LDO regulator, requires an external decoupling capacitor. 2.2uF is recommended when DC-DC is enabled, and not less than 0.1uF is recommended when not enabled.
2	4	VSW	Power	-	Internal DC-DC switch output, a 22uH or 33uH inductor connected to the VDCID must be close to the pin in serious when DC-DC is enabled. It can be directly connected to the VDCID when DC-DC is not enabled.
3	5	VIO33	Power	VBAT	I/O and DC-DC or battery power input, an external decoupling capacitor shall be close to the pin. 2.2uF is recommended when DC-DC is enabled, and not less than 1uF is recommended when DC-DC is not enabled.
4	None	PA7	I/O/A	TXD2 /PWM5 /AIN11	PA7: General-purpose bidirectional digital I/O pin. TXD2: UART2 serial data output. PWM5: Pulse width modulation output channel 5. AIN11: ADC analog signal input channel 11.
5	6	PA8	I/O/A	RXD1 /AINT12	PA8: General-purpose bidirectional digital I/O pin. RXD1: UART1 serial data input. AIN12: ADC analog signal input channel 12.
6	7	PA9	I/O/A	TXD1 /AINT13	PA9: General-purpose bidirectional digital I/O pin. TXD1: UART1 serial data output. AIN13: ADC analog signal input channel 13.
7	None	PB9	I/O	TXD1_	PB9: General-purpose bidirectional digital I/O pin.

				/SLVW	TXD1_ : TXD1 pin mapping of UART1. SLVW: Write control signal input of passive parallel port, active at low level.
8	None	PB8	I/O	RXD1_ /SLVR	PB8: General-purpose bidirectional digital I/O pin. RXD1_ : RXD1 pin mapping of UART1. SLVR: Read control signal input of passive parallel port, active at low level.
9	None	PB17	I/O	TCK	PB17: General-purpose bidirectional digital I/O pin. TCK: Serial clock input of the two-wire emulation debug interface.
10	None	PB16	I/O	TIO	PB16: General-purpose bidirectional digital I/O pin. TIO: Serial data input and output of the two-wire emulation debug interface, with built-in pull-up.
11	8	PB15	I/O/A /5VT	ER+ /MISO_	PB15: General-purpose bidirectional digital I/O pin. ER+: Ethernet receives RX+ signals. MISO_ : MISO pin mapping of SPI0.
12	9	PB14	I/O/A /5VT	ER- /MOSI_ /PWM10	PB14: General-purpose bidirectional digital I/O pin. ER-: Ethernet receives RX- signals. MOSI_ : MOSI pin mapping of SPI0. PWM10: Pulse width modulation output channel 10.
13	10	PB13	I/O/A /5VT	ET+ /SCK0_	PB13: General-purpose bidirectional digital I/O pin. ET+: Ethernet sends TX+ signals. SCK0_ : SCK pin mapping of SPI0.
14	11	PB12	I/O/A /5VT	ET- /SCS_	PB12: General-purpose bidirectional digital I/O pin. ET-: Ethernet sends TX- signals. SCS_ : SCS pin mapping of SPI0.
15	12	PB11	I/O/A	UD+ /TMR2_	PB11: General-purpose bidirectional digital I/O pin. UD+: D+ data line of USB bus. TMR2_ : TMR2 pin mapping of Timer 2.
16	13	PB10	I/O/A	UD- /TMR1_	PB10: General-purpose bidirectional digital I/O pin. UD-: D- data line of USB bus. TMR1_ : TMR1 pin mapping of Timer 1.
17	14	PB7	I/O	TXD0	PB7: General-purpose bidirectional digital I/O pin. TXD0: UART0 serial data output.
18	None	PB6	I/O	RTS	PB6: General-purpose bidirectional digital I/O pin. RTS: MODEM output signal of UART0, request to send.
19	None	PB5	I/O	DTR	PB5: General-purpose bidirectional digital I/O pin. DTR: MODEM output signal of UART0, data terminal ready.
20	15	PB4	I/O	RXD0	PB4: General-purpose bidirectional digital I/O pin. RXD0: UART0 serial data input.
21	None	PB3	I/O	DCD /PWM9	PB3: General-purpose bidirectional digital I/O pin. DCD: MODEM input signal of UART0, data carrier detection. PWM9: Pulse width modulation output channel 9.
22	None	PB2	I/O	RI /PWM8	PB2: General-purpose bidirectional digital I/O pin. RI: MODEM input signal of UART0, ringing indication. PWM8: Pulse width modulation output channel 8.
23	None	PB1	I/O	DSR /PWM7	PB1: General-purpose bidirectional digital I/O pin. DSR: MODEM input signal of UART0, data device ready. PWM7: Pulse width modulation output channel 7.
24	None	PB0	I/O	CTS /PWM6	PB0: General-purpose bidirectional digital I/O pin. CTS: MODEM input signal of UART0, clear to send. PWM6: Pulse width modulation output channel 6.
25	16	PB23	I/O	RST# /TXD2_ /PWM11	PB23: General-purpose bidirectional digital I/O pin. RST#: External reset input, active at low level, built-in pull-up resistor. TXD2_ : TXD2 pin mapping of UART2. PWM11: Pulse width modulation output channel 11.

26	17	PB22	I/O	RXD2_	PB22: General purpose bidirectional digital I/O pin. RXD2_ : RXD2 pin mapping of UART2.
27	None	PB21	I/O	TXD3_	PB21: General purpose bidirectional digital I/O pin. TXD3_ : TXD3 pin mapping of UART3.
28	None	PB20	I/O	RXD3_	PB20: General purpose bidirectional digital I/O pin. RXD3_ : RXD3 pin mapping of UART3.
29	None	PB19	I/O	TMR0_	PB19: General purpose bidirectional digital I/O pin. TMR0_ : TMR0 pin mapping of Timer 0.
30	None	PB18	I/O	TMR3_	PB18: General purpose bidirectional digital I/O pin. TMR3_ : TMR3 pin mapping of Timer 3.
31	18	X32MO	I/A	-	Inverted output of the high frequency oscillator HSE, it is externally connected to one end of 32 MHz crystal.
32	19	X32MI	A	-	Input of the high frequency oscillator HSE, it is externally connected to the other end of 32MHz crystal.
33	20	VINTA	Power	-	Power supply node of the internal analog circuit, an external decoupling capacitor shall be close to the pin, 2.2uF is recommended (It can be 1uF when DC-DC is not enabled, slightly saving more power but reducing BLE sensitivity).
34	21	ANT	A	-	RF signal input and output, it is recommended to be connected with the antenna directly.
35	22	VDCIA	Power	-	Power input of the internal analog circuit LDO regulator, an external decoupling capacitor is required. It is recommended not to be less than 0.1uF. It is recommended to directly connect to the VDCID.
36	23	PA4	I/O/A	RXD3 /LEDC /UCC1 /AIN0	PA4: General-purpose bidirectional digital I/O pin. RXD3: UART3 serial data input. LEDC: LED screen interface serial clock output. UCC1: USB type-C bidirectional configuration channel 1. AIN0: ADC analog signal input channel 0.
37	24	PA5	I/O/A	TXD3 /UCC2 /AIN1	PA5: General-purpose bidirectional digital I/O pin. TXD3: UART3 serial data output. UCC2: USB type-C bidirectional configuration channel 2. AIN1: ADC analog signal input channel 1.
38	None	PA6	I/O/A	RXD2 /PWM4 /AIN10	PA6: General-purpose bidirectional digital I/O pin. RXD2: UART2 serial data input. PWM4: Pulse width modulation output channel 4. AIN10: ADC analog signal input channel 10.
39	None	PA0	I/O/A	SCK1 /SLVA /LED0 /AIN9	PA0: General-purpose bidirectional digital I/O pin. SCK1: SPI1 serial clock output. SLVA: Address input of passive parallel ports, select command and status port when at high level, and select data port when at low level. LED0: LED screen interface serial data output 0. AIN9: ADC analog signal input channel 9.
40	None	PA1	I/O/A	MOSI1 /SLVS /LED1 /AIN8	PA1: General-purpose bidirectional digital I/O pin. MOSI1: SPI1 serial data output. SLVS: Chip select control input for passive parallel port, active at low level. LED1: LED screen interface serial data output 1. AIN8: ADC analog signal input channel 8.
41	None	PA2	I/O/A	TMR3 /MISO1 /LED2 /AIN7	PA2: General-purpose bidirectional digital I/O pin. TMR3: Capture input 3 and PWM output channel 3 of Timer 3. MISO1: SPI1 serial data input, reused for output in 2- wire mode. LED2: LED screen interface serial data output 2. AIN7: ADC analog signal input channel 7.
42	None	PA3	I/O/A	TMR0	PA3: General-purpose bidirectional digital I/O pin.

				/SLVI /LED3 /AIN6	TMR0: Capture input 0 and PWM output channel 0 of Timer 0. SLVI: Interrupt request output of passive parallel port, active at low level. LED3: LED screen interface serial data output 3. AIN6: ADC analog signal input channel 6.
43	25	PA15	I/O/A	MISO /RXD0_ /AIN5	PA15: General-purpose bidirectional digital I/O pin. MISO: SPI0 serial data pin, master input/slave output. RXD0_: RXD0 pin mapping of UART0. AIN5: ADC analog signal input channel 5.
44	26	PA14	I/O/A	MOSI /TXD0_ /UBUS /AIN4	PA14: General-purpose bidirectional digital I/O pin. MOSI: SPI0 serial data pin, master output / slave input. TXD0_: TXD0 pin mapping of UART0. UBUS: USB type-C bus voltage detection input. AIN4: ADC analog signal input channel 4.
45	27	PA13	I/O/A	SCK0 /AIN3	PA13: General-purpose bidirectional digital I/O pin. SCK0: SPI0 serial clock pin, master output / slave input. AIN3: ADC analog signal input channel 3.
46	28	PA12	I/O/A	SCS /AIN2	PA12: General-purpose bidirectional digital I/O pin. SCS: Chip select input in the SPI0 slave mode, active at low level. AIN2: ADC analog signal input channel 2.
47	1	PA11	I/O/A	X32KO /TMR2	PA11: General-purpose bidirectional digital I/O pin. X32KO: The inverted output end of the low frequency oscillator is externally connected to one end of the 32KHz crystal. TMR2: Capture input 2 and PWM output channel 2 of Timer 2.
48	2	PA10	I/O/A	X32KI /TMR1	PA10: General-purpose bidirectional digital I/O pin. X32KI: The input end of the low frequency oscillator is externally connected to the other end of the 32KHz crystal. TMR1: Capture input 1 and PWM output channel 1 of Timer 1.

Pin descriptions for reuse of segmented LCD drivers

Pin name	Type	Alternative function	Function description
PA0~PA3	A	COM0~COM3	Drive each common end of the segment LCD, and select some or all of them as needed.
PB0~PB23	A	SEG0~SEG23	Drive each segment of the segment LCD, and select some or all of them as needed. There is 6-bit RB_PIN_SEG*_IE in the R16_PIN_ANALOG_IE register. Each bit controls 4 segment pins at the same time. When the bit is 0, 4 pins are used for digital input or other non-LCD features. When the bit is 1, 4 pins are used for LCD segment drive.

Note:

(1) Pin type:

I = TTL / CMOS level Schmidt input;

O = CMOS level three-state output;

A = Analog signal input or output;

5VT=Support 5V signal voltage input.

(2) The multiplexing feature and the mapping of pins are arranged in the table according to their priorities from the highest to the lowest. Among them, the GPIO feature is the lowest priority.

Chapter 2 System Architecture and Memory

2.1 System architecture

The figure below illustrates the block diagram of the structure of the CH579 chip system.

Figure 2-1 CH579 internal structure block diagram

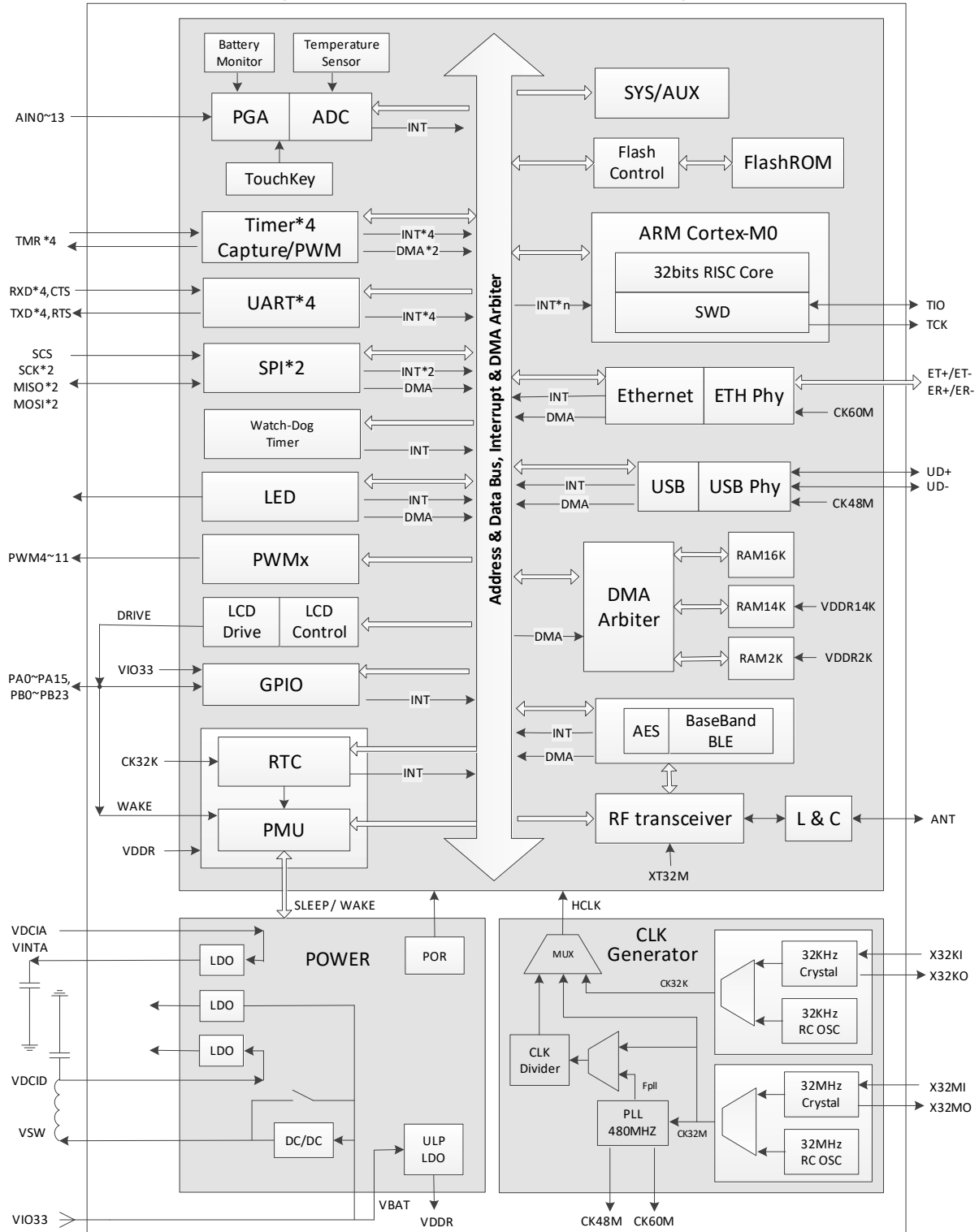

2.2 Memory mapping

The addressing space of CH579 mainly includes several different areas such as CODE area/FlashROM, DATA area/SRAM and peripherals, as shown in the figure below.

Figure 2-2 Memory mapping diagram

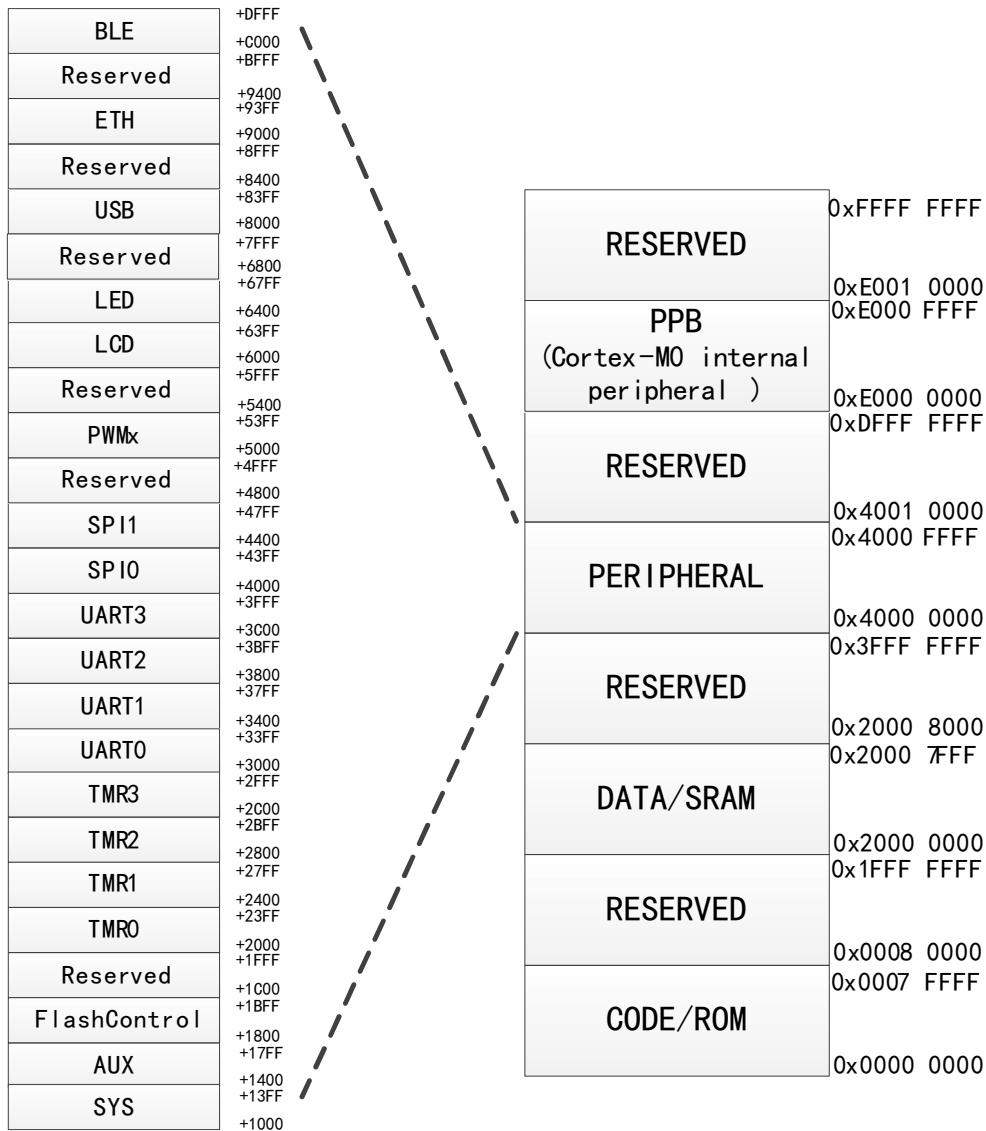

2.3 Memory mapping table

The address range of each memory mapping area is indicated in the following table:

Table 2-1 Addresses in the memory mapping area

Address range	Application	Description
0x00000000-0x0007FFFF	On-chip CODE area, non-volatile memory	257KB, FlashROM
0x00080000-0x1FFFFFFF	Reserved	-
0x20000000-0x20007FFF	On-chip DATA area, volatile memory	32KB, SRAM
0x20008000-0x3FFFFFFF	Reserved	-
0x40000000-0x4000FFFF	Various peripherals	Multiple peripheral modules
0x40010000-0xDFFFFFFF	Reserved	-
0xE0000000-0xE000FFFF	PPB	Internal peripheral bus area
0xE0010000-0xFFFFFFFF	Reserved	-

2.3.1 On-Chip CODE area mapping table

Table 2-2 Addresses in the CODE Area

Address range	Application	Description
0x00000000-0x0003E7FF	User application program memory area, CodeFlash	250KB
0x0003E800-0x0003EFFF	User non-volatile data memory area, DataFlash	2KB
0x0003F000-0x0003FFFF	System bootloader memory area, BootLoader	4KB
0x00040000-0x000403FF	System non-volatile configuration information memory area, InfoFlash	1KB
0x00040400-0x0007FFFF	Reserved	-

The configuration information on address 0x00040010 can be set by users through tools.

Table 2-3 User-level non-volatile configuration information

Bit address	Name	Application	Default value
Bit 2~Bit 0	RESERVED	Reserved	000b
Bit 3	CFG_RESET_EN	RST# External manual reset input pin enable	0
Bit 4	CFG_DEBUG_EN	2-wire emulation debug interface enable	1
Bit 5	RESERVED	Reserved	0
Bit 6	CFG_BOOT_EN	System BootLoader enable	1
Bit 7	CFG_ROM_READ	Code and data protection mode in FlashROM: 0—Disable the programmer to readout and program is confidential; 1—Allow readout	1
Bit 27~Bit 8	RESERVED	Reserved	0FFFFh
Bit 31~Bit 28	VALID_SIG	Valid indication of configuration information, a fixed value	0101b

2.3.2 On-Chip DATA area mapping table

Table 2-3 DATA area address

Address range	Application	Description
0x20000000-0x20003FFF	Memory area only supplied by the main power source, RAM16K	16KB
0x20004000-0x200077FF	Independently maintained memory area supplied by the main + auxiliary power source, RAM14K	14KB
0x20007800-0x20007FFF	Independently maintained memory area supplied by the main + auxiliary power source, RAM2K	2KB

2.3.3 Peripheral address assignment

CH579 mainly includes the following peripherals. Each peripheral occupies a certain address space. The actual access address of the peripheral registers is: base address + offset address. In the following sections, the address of the register is described in detail. The following table indicates the assignment table for each peripheral base address.

Table 2-5 Assignment table for peripheral base addresses

Peripheral No.	Peripheral name	Peripheral base address
1	SYS (PMU/RTC/GPIO, etc.)	0x4000 1000
2	AUX (ADC/TKEY/PLL, etc.)	0x4000 1400
3	FlashROM-Control	0x4000 1800
4	TMR0	0x4000 2000
5	TMR1	0x4000 2400
6	TMR2	0x4000 2800
7	TMR3	0x4000 2C00
8	UART0	0x4000 3000

9	UART1	0x4000 3400
10	UART2	0x4000 3800
11	UART3	0x4000 3C00
12	SPI0	0x4000 4000
13	SPI1	0x4000 4400
14	PWMx(PWM4~PWM11)	0x4000 5000
15	LCD	0x4000 6000
16	LED	0x4000 6400
17	USB	0x4000 8000
18	ETH	0x4000 9000
19	Radio:BLE	0x4000 C000 0x4000 D000

The following table provides an explanation of "access" of the register described in the following sections:

Table 2-6 Description of access attributes

Abbreviation	Description
RF	Read-only. The read-out value is fixed and is not affected by reset.
RO	Read-only.
WO	Write-only. The read-out value is 0 or invalid.
RZ	Read-only. It is cleared to 0 automatically after reading.
WZ	It is cleared to 0 after writing.
RW	Readable and writable.
RW1	Readable. It is cleared to 0 after writing 1.
WA	Write-only. The read-out value is 0 or invalid only in the safe mode.
RWA	Readable. Writable only in the safe mode.

The following table explains the abbreviations used in the subsequent sections:

Table 2-7 Description of noun abbreviations

Abbreviation	Description
HSE	External high frequency crystal oscillator clock source (32MHz recommended)
HSI	Internal high frequency RC clock oscillation source (32MHz after factory calibration)
LSE	External low frequency crystal oscillator clock source (32KHz recommended)
LSI	Internal low frequency RC clock oscillation source (32KHz after calibration when the application software is running)
CK32M	High frequency clock source (32MHz at default)
CK32K	Low frequency clock source (32KHz at default)
Fpll	PLL output clock (the default frequency is 480MHz)
HCLK	System main frequency clock
Fsys	Frequency of system main-frequency clock
Tsys	Cycle of system main-frequency clock (1/Fsys)
RAM2K	2KB SRAM of the highest address
RAM14K	14KB SRAM of the next highest address
0x	The data starting with it represents a hexadecimal number
H	The data ending with it represents a hexadecimal number
B	The data ending with it represents a binary number

Chapter 3 Interrupt

3.1 Interrupt controller

The system supports up to 20 sets of interrupt signal sources. Each interrupt request has independent trigger and disabling control bits as well as dedicated status bits.

3.2 SysTick calibration value

When the SysTick clock is set to 32MHz, the SysTick calibration value is fixed at 32,000, which will generate a time reference of 1ms.

3.3 Interrupt and exception vectors

The following table lists the vector table of the chip system.

Table 3-1 Interrupt vectors

Position	Priority	Priority type	Name	Description	Address
	-	-	-	Reserved	0x0000_0000
-15	-3	Fixed	Reset	Reset	0x0000_0004
-14	-2	Fixed	NMI	Non-maskable interrupts	0x0000_0008
-13	-1	Fixed	Hard fault	Failures of all types	0x0000_000C
	-	-	-	Reserved	-
-5	0	Settable	SVCall	System service call via SWI instruction	0x0000_002C
	-	-	-	Reserved	-
-2	1	Settable	PendSV	Suspend system service	0x0000_0038
-1	2	Settable	SysTick	SysTick timer	0x0000_003C
0	3	Settable	TMR0	TMR0 Timer 0 interrupt	0x0000_0040
1	4	Settable	GPIO	GPIO general-purpose I/O interrupt	0x0000_0044
2	5	Settable	SLAVE	Passive parallel port interrupt	0x0000_0048
3	6	Settable	SPI0	SPI0 interrupt	0x0000_004C
4	7	Settable	BLEL	LLE interrupt of wireless module	0x0000_0050
5	8	Settable	BLEB	BB interrupt of wireless module	0x0000_0054
6	9	Settable	USB	USB interrupt	0x0000_0058
7	10	Settable	ETH	Ethernet interrupt	0x0000_005C
8	11	Settable	TMR1	TMR1 Timer 1 interrupt	0x0000_0060
9	12	Settable	TMR2	TMR2 Timer 2 interrupt	0x0000_0064
10	13	Settable	UART0	UART0 Asynchronous serial port 0 interrupt	0x0000_0068
11	14	Settable	UART1	UART1 Asynchronous serial port 1 interrupt	0x0000_006C
12	15	Settable	RTC	RTC real-time clock interrupt	0x0000_0070
13	16	Settable	ADC	ADC interrupt	0x0000_0074
14	17	Settable	SPI1	SPI1 interrupt	0x0000_0078
15	18	Settable	LED	LED screen control interrupt	0x0000_007C
16	19	Settable	TMR3	TMR3 Timer 3 interrupt	0x0000_0080
17	20	Settable	UART2	UART2 Asynchronous serial port 2 interrupt	0x0000_0084
18	21	Settable	UART3	UART3 Asynchronous serial port 3 interrupt	0x0000_0088
19	22	Settable	WDOG_ BAT	Watchdog timer interrupt/battery low voltage interrupt	0x0000_008C

Chapter 4 System control

4.1 Reset control

The system supports 6 forms of reset: RPOR (real power on reset), external MR (manual reset), internal SR (software reset), WTR (watch-dog time-out reset), GRWSM (global reset by waking under shutdown mode) and LRW (local reset by waking).

Register R8_GLOB_RESET_KEEP and register RB_ROM_CODE_OFS are only reset when RPOR and GRWSM occur, and they are not affected by other forms of reset.

For the timing parameters and reset characteristic parameters in the figure below, please refer to the timing parameter table in Section 20.5.

4.1.1 Real Power on Reset (RPOR)

When power is turned on, power-on reset is generated inside the chip and delayed to wait for the power supply to stabilize. The figure below illustrates the process of power-on reset.

Figure 4-1 Real power on reset

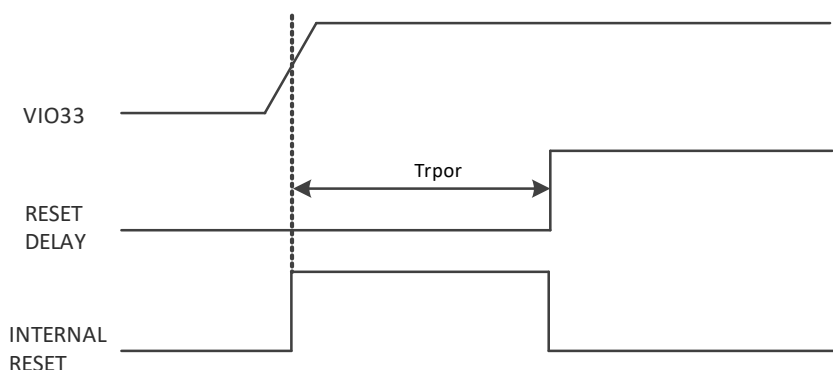

4.1.2 External Manual Reset (MR)

External manual reset is triggered by a low level externally applied to the RST# pin. When the reset low level duration is greater than the minimum reset pulse width (T_{rst}), the system is triggered to reset.

Figure 4-2 External manual reset

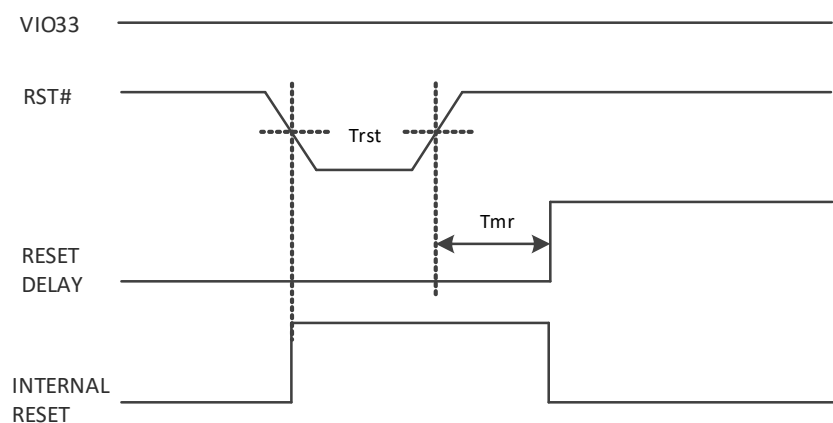

4.1.3 Internal Software Reset (SR)

Internal software reset is used to automatically reset without external intervention. Software reset can be implemented by setting the bit RB_SOFTWARE_RESET of the global reset configuration register (R8_RST_WDOG_CTRL) to '1'. This bit is automatically cleared to 0.

4.1.4 Watchdog Timeout Reset (WTR)

The watchdog feature is based on an 8-bit count-up counter with a count clock cycle of $131072/F_{sys}$. When the feature of watchdog timeout reset is turned on, the entire system will be reset once the counter overflows.

4.1.5 Watchdog Timeout Reset (WTR)

Once the system enters the shutdown mode (see the chapter of Power Management for details), the system will perform the wake-up operation in an orderly manner under the action of wake-up signals. After wakeup, the system will perform a global reset. The effect of this reset is similar to that of power-on reset.

4.1.6 Local Reset by Waking (LRW)

If the system is woken up from sleep mode, a reset will be generated after the associated power supply is ready. This reset is a partial reset, with a selective reset of the registers that are powered down in the sleep mode as needed. In the sleep mode, the registers of each feature module are divided into three categories:

The first type is key registers (e.g., configuration/mode, etc.) belonging to a feature module that requires data retention. At the time of sleep, the auxiliary power supply continues to supply power, and the data is not lost. Both sleep and wakeup have no effect on their data;

The second type is regenerative registers (e.g., counter, FIFO, etc.) belonging to a feature module that requires data retention. Power is turned off during sleep, and the data is a random number (e.g., a FIFO memory cell) or is reset (e.g., a FIFO counter) after wakeup;

The third type is registers belonging to a feature module that does not require data retention. Power is turned off during sleep, and the data is a random number (e.g., a FIFO memory cell) or is reset after wakeup (e.g., a FIFO counter, configuration/mode register).

LRW is used for the second and third type of reset registers.

4.2 Safe access

The properties of some registers of the system are "RWA" or "WA", indicating that the current register can be safely accessed and can be read directly, but write-in needs to enter the secure access mode.

First write in R8_SAFE_ACCESS_SIG register 0x57;

Then write in R8_SAFE_ACCESS_SIG register 0xA8;

At this time, you can enter the mode of safe access and operate the register with the "RWA/WA" attribute. Afterwards, about 16 system main frequency cycles (Tsys) are in the safe mode. One or more security-class registers can be overwritten during the validity period. If the above validity period is exceeded, the security mode will be automatically terminated. Alternatively, the security mode can be terminated in advance by writing in 0x00 to the R8_SAFE_ACCESS_SIG register.

4.3 Register description

Table 4-1 List of registers related to system control

Name	Access address	Description	Default value
R8_SAFE_ACCESS_SIG	0x40001040	Safe access flag register	0x00
R8_CHIP_ID	0x40001041	Chip ID register	0x79
R8_SAFE_ACCESS_ID	0x40001042	Safe access ID register	0x04
R8_WDOG_COUNT	0x40001043	Watchdog counter register	0x00
R8_RESET_STATUS	0x40001044	Reset status register	0x01
R8_GLOB_CFG_INFO	0x40001045	Global configuration information status register	0xEX
R8_RST_WDOG_CTRL	0x40001046	Watchdog and reset configuration register	0x00
R8_GLOB_RESET_KEEP	0x40001047	Reset hold register	0x00
R8_CFG_FLASH	0x4000104A	FlashROM configuration register	0x0X
R32_FLASH_DATA	0x40001800	FlashROM data register	0xFFFFFFFF XX
R32_FLASH_ADDR	0x40001804	FlashROM address register	0xFFFFFFFF XX
R8_FLASH_COMMAND	0x40001808	FlashROM command register	0x00
R8_FLASH_PROTECT	0x40001809	FlashROM protection control register	0x00
R16_FLASH_STATUS	0x4000180A	FlashROM status register	0x0X00

Safe Access Flag Register (R8_SAFE_ACCESS_SIG)

Bit	Name	Access	Description	Reset value
[7:0]	R8_SAFE_ACCESS_SIG	WO	Secure access flag register. Some registers (access attribute is RWA) are protection registers and must enter the mode of safe access for write operations. Write 0x57 to this register and then write 0xA8 to enter the mode of safe access. The time limit is about 16 main clock cycles (Tsys). If it is exceeded, automatic protection is enabled. You can write any other value to force direct exit from the mode of safe access and return to the protection state.	00h
7	Reserved	RO	Reserved	0
[6:4]	RB_SAFE_ACC_TIMER	RO	Current count of the time of safe access.	000b
3	RB_SAFE_ACC_ACT	RO	Status of current safe access mode: 1: Writeable in the mode of unlocked/safe access; 0: Locked, the RWA attribute register cannot be rewritten.	0
2	Reserved	RO	Reserved	0
[1:0]	RB_SAFE_ACC_MODE	RO	Status of current safe access mode: 11: Safe mode; can be written into attribute RWA register; Other: Non-safe mode.	00b

Chip ID Register (R8_CHIP_ID)

Bit	Name	Access	Description	Reset value
[7:0]	R8_CHIP_ID	RF	A fixed value of 79h is used to identify the chip.	79h

Safe Access ID Register (R8_SAFE_ACCESS_ID)

Bit	Name	Access	Description	Reset value
[7:0]	R8_SAFE_ACCESS_ID	RF	A fixed value of 04h	04h

Watchdog Counter Register (R8_WDOG_COUNT)

Bit	Name	Access	Description	Reset value
[7: 0]	R8_WDOG_COUNT	RW	The watchdog counter, which can be preset with the initial value, is automatically incremented and can be cycled from 0xFF to 0x00 and then continue. Count cycle = 131072/Fsys.	00h

Reset Status Register (R8_RESET_STATUS)

Bit	Name	Access	Description	Reset value
[7:5]	Reserved	RO	Reserved	000b
4	RB_ROM_CODE_OFS	RWA	Select the starting offset address of the user program code in FlashROM. This value is not affected by MR, SR or WTR and can only be cleared when RPOR and GRWSM are valid: 0: 0x000000; 1: 0x008000 (skip the first 32KB in ROM).	0
3	Reserved	RO	Reserved	0
[2:0]	RB_RESET_FLAG	RO	Last reset status: 000: Software reset SR (when RB_WDOG_RST_EN=0, software reset can generate this state, otherwise it can be reset but does not produce this state); 001: Real Power On Reset (RPOR);	001b

			010: Watchdog Timeout Reset (WTR); 011: External Manual Reset (MR); 101: Global Reset by Waking Under Shutdown Mode (GRWSM); 100/110/111: Local Reset by Waking (LRW), and the last reset before is SR/WTR/MR.	
--	--	--	---	--

Global Configuration Information Status Register (R8_GLOB_CFG_INFO)

Bit	Name	Access	Description	Reset value
[7: 6]	Reserved	RO	Reserved	11b
5	RB_BOOT_LOADER	RO	Bootloader status: 1: Currently in the bootloader state; 0: Currently in the user program state.	1/0
4	RB_CFG_DEBUG_EN	RO	2-wire emulation debug interface is enabled: 1: Can simulate debugging, can read FlashROM; 0: Debugging simulation is disabled.	0
3	RB_CFG_BOOT_EN	RO	The system BootLoader enable status: 1: Enabled; 0: Not enabled.	1
2	RB_CFG_RESET_EN	RO	RST# external manual reset input enable status: 1: Enabled; 0: Not enabled.	0
1	Reserved	RO	Reserved	0
0	RB_CFG_ROM_READ	RO	FlashROM code and data area protection status: 1: The external programmer is readable; 0: Protected, externally inaccessible; the program is kept secret.	0

Watchdog and Reset Configuration Register (R8_RST_WDOG_CTRL)

Bit	Name	Access	Description	Reset value
[7:5]	Reserved	RO	Reserved	000b
4	RB_WDOG_INT_FLAG	RW1	Watchdog timer interrupt flag: 1: A watchdog count overflow occurs, that is, R8_WDOG_COUNT is detected to be incremented from 0xFF to 0x00; 0: The watchdog count has not overflowed. For the flag: write 1 to clear, or reload the value of the watchdog counter (R8_WDOG_COUNT) to clear, or execute SEV() to clear.	0
3	Reserved	RO	Reserved	0
2	RB_WDOG_INT_EN	RWA	Watchdog Timer Interrupt Enable bit: 1: Enabled, an interrupt is generated after the watchdog count overflows; 0: Disable the watchdog timer interrupt.	0
1	RB_WDOG_RST_EN	RWA	Watchdog Timeout Reset Enable bit: 1: Enable: the system resets after watchdog count overflows; 0: Only as a watchdog timer. <i>Note: The software reset operation will not affect the status of RB_RESET_FLAG after this bit is set to 1.</i>	0
0	RB_SOFTWARE_RESET	WA/ WZ	System software reset control, automatically cleared after reset:	0

			1: Perform system software reset; 0: Idle, no action.	
--	--	--	--	--

Reset Hold Register (R8_GLOB_RESET_KEEP)

Bit	Name	Access	Description	Reset value
[7:0]	R8_GLOB_RESET_KEEP	RW	The reset hold register is not affected by manual reset, software reset, watchdog reset, or normal wake-up reset.	00h

FlashROM Configuration Register (R8_CFG_FLASH)

Bit	Name	Access	Description	Reset value
7	RB_FLASH_BUSY_EN	RWA	Busy enable bit when FlashROM is acceded in bursts: 1: Waiting (recommended); 0: No waiting.	0
[6:4]	Reserved	RO	Reserved	000b
[3:0]	RB_CFG_FLASH_X	RWA	FlashROM configuration data must be kept unchanged when being written in.	XXXXb

FlashROM Data Register (R32_FLASH_DATA)

Bit	Name	Access	Description	Reset value
[31:0]	R32_FLASH_DATA	RW	FlashROM data register	XXXXXXXXXh

FlashROM Address Register (R32_FLASH_ADDR)

Bit	Name	Access	Description	Reset value
[31:0]	R32_FLASH_ADDR	RW	FlashROM address register	XXXXXXXXXh

FlashROM Command Register (R8_FLASH_COMMAND)

Bit	Name	Access	Description	Reset value
[7:0]	R8_FLASH_COMMAND	WO	0x9A: FlashROM programming operation command; 0xA6: FlashROM sector erase operation command.	00h

FlashROM Protection Control Register (R8_FLASH_PROTECT)

Bit	Name	Access	Description	Reset value
[7:6]	RB_ROM_WE_MUST_10	WO	Must write 10b, otherwise it can't be written.	10b
[5:4]	Reserved	RO	Reserved	00b
3	RB_ROM_CODE_WE	RW	Erase/Programming Enable bit of FlashROM program memory area CodeFlash: 1: Allow erase/programming; 0: Erase/programming protection.	0
2	RB_ROM_DATA_WE	RW	Erase/Programming Enable bit of FlashROM program memory area DataFlash: 1: Allow erase/programming; 0: Erase/programming protection.	0
[1:0]	Reserved	RO	Reserved	00b

FlashROM Status Register (R16_FLASH_STATUS)

Bit	Name	Access	Description	Reset value
[15:11]	Reserved	RO	Reserved	00000b
[10:9]	Reserved	RO	Reserved	01b
8	RB_ROM_READ_FREE	RO	FlashROM code and data area protection status: 1: The external programmer is readable; 0: Protected, externally inaccessible, and the program is kept secret.	0

7	Reserved	RO	Reserved	0
6	RB_ROM_ADDR_OK	RO	FlashROM erase/program operation address valid flag It can be confirmed before or after the operation: 1: The address is valid; 0: The address is invalid.	0
[5:2]	Reserved	RO	Reserved	0000b
1	RB_ROM_CMD_ERR	RO	FlashROM command response error: 1: Unknown command; 0: Command accepted.	0
0	RB_ROM_CMD_TOUT	RO	FlashROM operation results: 1: Timeout; 0: Successful.	0

4.4 Flash-ROM Operation Procedure

- Erase the Flash-ROM and change all data bits in the target sector to 1:
 - Set the R8_FLASH_PROTECT register; turn on the erase/program to enable RB_ROM_DATA_WE or RB_ROM_CODE_WE bit, corresponding to DataFlash or CodeFlash. InfoFlash requires RB_ROM_DATA_WE and RB_ROM_CODE_WE both to be enabled;
 - Set the address register R32_FLASH_ADDR, write in 32-bit address (the low 8 bits are invalid), and erase the entire block 512 bytes at a time;
 - Set the command register R8_FLASH_COMMAND, write in 0A6H, and perform the operation of sector erase. The MCU automatically suspends running during the operation;
 - After the operation is completed, the program resumes running. At this time, the status register R16_FLASH_STATUS is queried to check the operation status. If multiple sectors are to be erased, Step (2) to Step (4) are performed in cycles;
 - Re-set the R8_FLASH_PROTECT register and turn off the erase/program enable control bit (RB_ROM_DATA_WE=0 or RB_ROM_CODE_WE=0).
- Write the Flash-ROM to change part of the data bits in the target word from 1 to 0 (the bit data cannot be changed from 0 to 1):
 - Set the R8_FLASH_PROTECT register; turn on the erase/program to enable RB_ROM_DATA_WE or RB_ROM_CODE_WE bit, corresponding to DataFlash or CodeFlash. InfoFlash requires RB_ROM_DATA_WE and RB_ROM_CODE_WE both to be enabled;
 - Set the address register R32_FLASH_ADDR, write in the 32-bit address, require 4 bytes alignment;
 - Set the data register R32_FLASH_DATA to be 4 bytes of data to be written;
 - Set the command register R8_FLASH_COMMAND, write 09AH, and execute the operation of program/write-in. The MCU automatically suspends running during the operation;
 - After the operation is completed, the program resumes running. At this time, the status register R16_FLASH_STATUS is queried to view the operation status. If multiple data is to be written, Step (2) to Step (4) are performed in cycles;
 - Reset the R8_FLASH_PROTECT register to turn off the erase/program enable control bit (RB_ROM_DATA_WE=0 or RB_ROM_CODE_WE=0).
- Read Flash-ROM:
Read the code or data of the target address by a pointer to the program memory space.

4.5 Unique Chip ID Number

Each chip is shipped with a unique ID number, namely the chip ID number. The ID data and its checksum are 8 bytes in total and are stored in the read-only area of the chip. For details, please refer to the example program.

Chapter 5 Power Control

5.1 Power management

The CH579 has a built-in power management unit (PMU). The system power is input from VIO33 and provides the required power for the system's FlashROM, the system's digital circuits (including core, USB, Ethernet, LED, etc.) and the system's analog circuits (including high-frequency oscillators, PLLs, ADCs, RF transceivers, etc.) through the multiple built-in LDO voltage regulators.

There are two types of power supply during normal operation: direct power and DC-DC conversion. In addition to normal operation, the CH579 offers four types of low-power modes: idle mode, halt mode, sleep mode, and shutdown mode.

Instead of enabling DC-DC by default after power-on, a straight-through power supply is provided with a small voltage ripple. In order to reduce the system power consumption during normal operation, DC-DC can be enabled to increase the power consumption rate of the power supply, and the operating current will usually drop to about 60% of that of the straight-through mode.

In order to reduce the system power consumption during sleep, you can choose to turn off the system main LDO and switch to the auxiliary power supply provided by the system built-in ultra-low power ULP-LDO. When the system enters the mode of sleep or shutdown, in addition to the normal power supply units such as power management and RTC registers, you can choose whether to maintain power supply of the system high 2KB and 14KB SRAM, core kernel and all peripherals and whether to enable LSE/LSI.

Figure 5-1 Power system

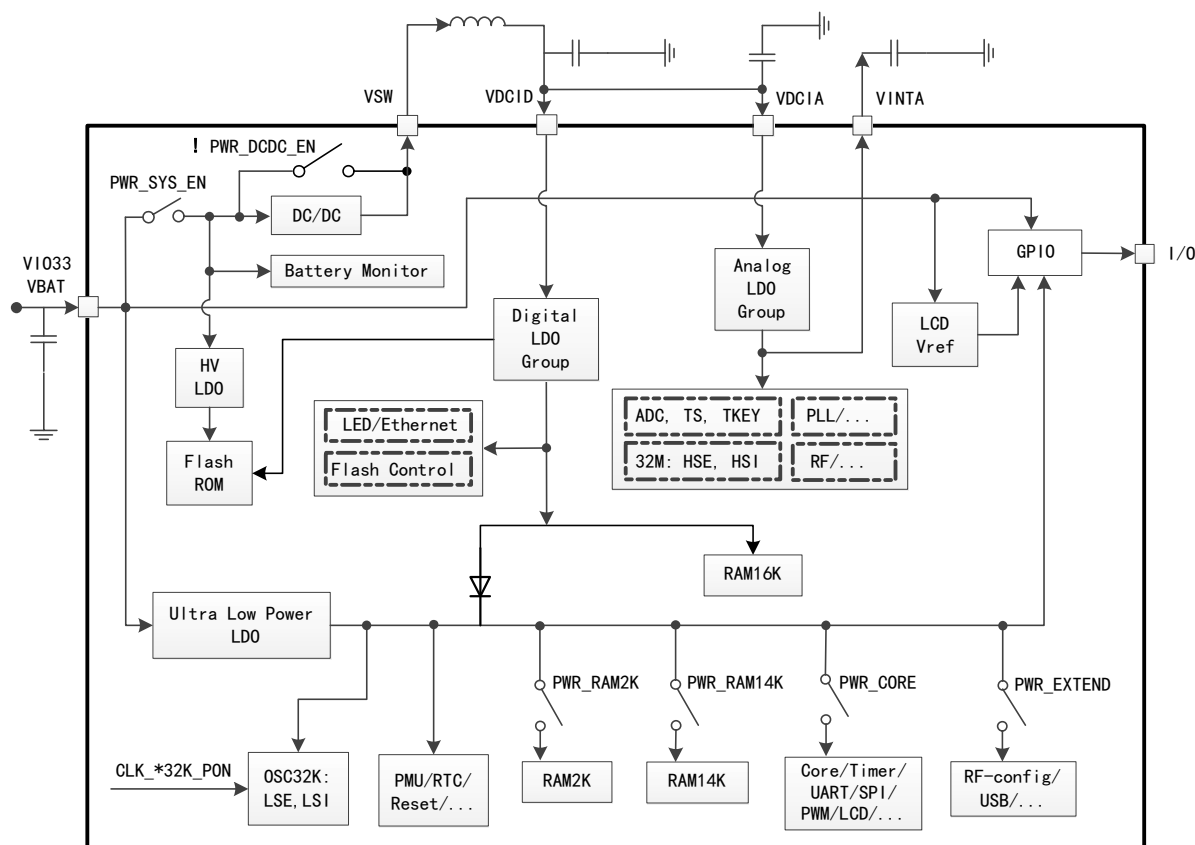

5.2 Register description

Table 5-1 List of registers related to power management

Name	Access Address	Description	Reset value
R16_SLP_CLK_OFF	0x4000100C	Sleep clock control register	0x0000
R8_SLP_CLK_OFF0	0x4000100C	Sleep clock control register 0	0x00
R8_SLP_CLK_OFF1	0x4000100D	Sleep clock control register 1	0x00

R8_SLP_WAKE_CTRL	0x4000100E	Wakeup event configuration register	0x20
R8_SLP_POWER_CTRL	0x4000100F	Peripheral sleep power control register	0x08
R16_POWER_PLAN	0x40001020	Sleep power management register	0x01DF
R16_AUX_POWER_ADJ	0x40001022	Auxiliary power adjustment control register	0xXXXX
R8_BAT_DET_CTRL	0x40001024	Battery voltage detection control register	0x00
R8_BAT_DET_CFG	0x40001025	Battery voltage detection configuration register	0x01
R8_BAT_STATUS	0x40001026	Battery status register	0x00

Sleep Clock Control Register 0 (R8_SLP_CLK_OFF0)

Bit	Name	Access	Description	Reset value
7	RB_SLP_CLK_UART3	RWA	UART3 clock source: 1: Off; 0: On.	0
6	RB_SLP_CLK_UART2	RWA	UART2 clock source: 1: Off; 0: On.	0
5	RB_SLP_CLK_UART1	RWA	UART1 clock source: 1: Off; 0: On.	0
4	RB_SLP_CLK_UART0	RWA	UART0 clock source: 1: Off; 0: On.	0
3	RB_SLP_CLK_TMR3	RWA	Timer 3 clock source: 1: Off; 0: On.	0
2	RB_SLP_CLK_TMR2	RWA	Timer 2 clock source: 1: Off; 0: On.	0
1	RB_SLP_CLK_TMR1	RWA	Timer 1 clock source: 1: Off; 0: On.	0
0	RB_SLP_CLK_TMR0	RWA	Timer 0 clock source: 1: Off; 0: On.	0

Sleep Clock Control Register 1 (R8_SLP_CLK_OFF1)

Bit	Name	Access	Description	Reset value
7	RB_SLP_CLK_BLE	RWA	BLE controller clock source: 1: Off; 0: On.	0
6	RB_SLP_CLK_LED	RWA	LED controller clock source: 1: Off; 0: On.	0
5	RB_SLP_CLK_ETH	RWA	ETH controller clock source: 1: Off; 0: On.	0
4	RB_SLP_CLK_USB	RWA	USB controller clock source: 1: Off; 0: On.	0
3	RB_SLP_CLK_LCD	RWA	LCD controller clock source: 1: Off; 0: On.	0
2	RB_SLP_CLK_PWMX	RWA	PWMx clock source: 1: Off; 0: On.	0
1	RB_SLP_CLK_SPI1	RWA	SPI1 clock source: 1: Off; 0: On.	0
0	RB_SLP_CLK_SPI0	RWA	SPI0 clock source: 1: Off; 0: On.	0

Wakeup Event Configuration Register (R8_SLP_WAKE_CTRL)

Bit	Name	Access	Description	Reset value
[7:6]	Reserved	RO	Reserved	00b
5	RB_SLP_BAT_WAKE	RWA	Enable battery low voltage event wake-up system: 1: Enabled; 0: Disable.	1
4	RB_SLP_GPIO_WAKE	RWA	Enable the GPIO event wakeup system: 1: Enabled; 0: Disable.	0
3	RB_SLP_RTC_WAKE	RWA	Enable the RTC event wakeup system:	0

			1: Enabled; 0: Disable.	
2	Reserved	RO	Reserved	0
1	RB_SLP_ETH_WAKE	RWA	Enable the Ethernet event wakeup system: 1: Enabled; 0: Off.	0
0	RB_SLP_USB_WAKE	RWA	Enable the USB event wakeup system: 1: Enabled; 0: Off.	0

Peripheral Sleep Power Control Register (R8_SLP_POWER_CTRL)

Bit	Name	Access	Description	Reset value
[7:6]	Reserved	RO	Reserved	00b
5	RB_SLP_CLK_RAM2K	RWA	SRAM clock control of RAM2K: 1: Off; 0: On.	0
4	RB_SLP_CLK_RAMX	RWA	Clock control of the main SRAM (RAM16K + RAM14K) 1: Off; 0: On.	0
3	RB_SLP_ROM_PWR_DN	RWA	In halt mode, the FlashROM shutdown enable: 1: Put the ROM into the disabled state in halt mode; 0: The ROM is kept in the standby mode in halt mode.	1
2	Reserved	RO	Reserved	0
1	RB_SLP_ETH_PWR_DN	RWA	Ethernet transceiver ETH PHY power down enable: 1: Power down/disable; 0: Keep power supply.	0
0	Reserved	RO	Reserved	0

Sleep Power Management Register (R16_POWER_PLAN)

Bit	Name	Access	Description	Reset value
15	RB_PWR_PLAN_EN	RWA/ WZ	Sleep power planning control enable: 1: Start planning; 0: Close or end the plan. Turn on the power plan for execution when it enters the sleep or shutdown mode later. This bit is automatically cleared to zero after execution.	0
[14:11]	RB_PWR_MUST_0010	RWA	Reserved. Must write 0010b.	0000b
10	RB_PWR_DCDC_PRE	RWA	DC-DC bias circuit enable (immediately effective): 1: Enable; 0: Disabled.	0
9	RB_PWR_DCDC_EN	RWA	DC-DC enable bit (immediately effective): 1: DC-DC is enabled, and the pass-through power is off; 0: DC-DC is disabled and the pass-through power is on.	0
8	RB_PWR_LDO_EN	RWA	Internal LDO control (sleep planning) 1: Turn on LDO; 0: Plan to turn off LDO, saving more power.	1
7	RB_PWR_SYS_EN	RWA	System power control (sleep planning): 1: Provide system power (on the VSW pin); 0: Turn off the system power, and plan to enter the sleep mode or power-off mode.	1
6	Reserved	RWA	Reserved. Must write 0.	1
5	Reserved	RO	Reserved	0
4	RB_PWR_RAM14K	RWA	SRAM power supply of RAM14K (sleep planning):	1

			1: Dual power supply; 0: No auxiliary power supply required.	
3	RB_PWR_EXTEND	RWA	USB and RF configuration power supply (sleep planning): 1: Dual power supply; 0: No auxiliary power supply.	1
2	RB_PWR_CORE	RWA	Power supply of the core and basic peripherals (sleep planning): 1: Dual power supply; 0: No auxiliary power supply.	1
1	RB_PWR_RAM2K	RWA	SRAM power supply of RAM2K (sleep planning): 1: Dual power supply; 0: No auxiliary power supply.	1
0	Reserved	RO	Reserved	1

Bits of this register other than RB_PWR_DCDC_PRE and RB_PWR_DCDC_EN are all sleep planning preset, and its power configuration takes effect after entering the low-power sleep mode and the shutdown mode.

Auxiliary Power Adjustment Control Register (R16 AUX_POWER_ADJ)

Bit	Name	Access	Description	Reset value
[15:8]	Reserved	RO	Reserved, read-only bits, write operations are not affected.	XXb
[7:6]	Reserved	RO	Reserved	00b
[5:3]	Reserved	RWA	Reserved. The original value must be kept unchanged when write-in.	1XXb
[2:0]	RB_ULPLDO_ADJ	RWA	Auxiliary power supply output voltage regulation value of ultra-low power LDO (The values are only for reference and not recommended to modify.): 000: 0.908V; 001: 0.931V; 010: 0.954V; 011: 0.977V; 100: 1.000V; 101: 1.023V; 110: 1.046V; 111: 1.069V.	XXXb (100b)

Battery Voltage Detection Control Register (R8 BAT_DET_CTRL)

Bit	Name	Access	Description	Reset value
[7:4]	Reserved	RO	Reserved	0000b
3	RB_BAT_LOW_IE	RWA	Battery low voltage interrupt enable: 1: Enabled; 0: Off.	0
2	RB_BAT_LOWER_IE	RWA	Battery ultra-low voltage interrupt enable: 1: Enabled; 0: Off.	0
1	Reserved	RO	Reserved	0
0	RB_BAT_DET_EN	RWA	Battery voltage detection feature enable: 1: Enable low-voltage detection, and turn on the reference voltage and other modules at the same time. The current is 210uA in sleep mode; 0: Off.	0

Note: If the battery voltage reaches the detection threshold value of ultra-low voltage and both RB_BAT_LOWER_IE and RB_BAT_LOW_IE are enabled (normally only one of them is enabled), non-maskable interrupt (NMI) will be generated, which is equivalent to increasing the interrupt priority.

Battery Voltage Detection Configuration Register (R8 BAT_DET_CFG)

Bit	Name	Access	Description	Reset value
[7:2]	Reserved	RO	Reserved	000000b
[1:0]	RB_BAT_LOW_VTH	RWA	Set the detection threshold for low voltage	01b

			and ultra-low voltage: (Ultra-low voltage reference threshold, low voltage reference threshold) 00:1.97V , 2.25V; 01:2.05V , 2.33V; 10:2.13V , 2.41V; 11:2.21V , 2.49V.	
--	--	--	--	--

Battery Status Register (R8_BAT_STATUS)

Bit	Name	Access	Description	Reset value
[7:2]	Reserved	RO	Reserved	000000b
1	RB_BAT_STAT_LOW	RO	The battery is in a low voltage state: 1: Below the low voltage threshold; 0: No.	0
0	RB_BAT_STAT_LOWER	RO	The battery is in an ultra-low voltage state: 1: Below the ultra-low voltage threshold; 0: No.	0

5.3 Low-power mode

After the system is reset, the micro-controller is in normal run status. When the MCU is not required to run, the appropriate low power mode can be selected to save power. The user needs to select a suitable low power mode based on conditions such as the lowest power consumption, the fastest start time, and available wake-up events.

A chip is provided with the following four main low-power modes:

- Idle mode

All peripherals remain powered; the core stops running; the clock system runs. Once a wake-up event is detected, it can be woken up immediately.

- Halt mode

On the basis of the idle mode, the clock system stops, and the FlashROM can be put into the stop mode to further reduce power consumption. After the wakeup event is detected, the clock runs firstly and then the kernel is woken up to run.

- Sleep mode

The main LDO is turned off. The ultra-low-power ULP-LDO maintains the PMU, the core, and the basic peripherals. Users can choose whether to turn on LSE or LSI and whether to maintain the power supply of RAM2K, RAM14K, USB, and RF configurations. Upon detection of a wake-up event, the main LDO is first turned on; then the clock runs; in the end, the core is woken up and the program continues to run. A higher frequency can be reset when needed.

- Shutdown mode:

Based on the sleep mode, the core, basic peripherals and USB and RF configurations are turned off. Users can choose whether to turn on the LSE or LSI and whether to maintain the power supply of RAM2K and RAM14K. Upon detection of a wake-up event, the PMU will perform the GRWSM reset and the software can distinguish RPOR based on the reset flag of RB_RESET_FLAG and the data retention area in the optional RAM.

The following table details the features and wake-up paths of several low-power modes:

Table 5-2 Low-power modes

Mode	Feature	Access conditions	Wake-up event	Power consumption
Idle	The peripherals are powered normally; the core stops running; the clock system is in operation. Users can select to turn off the peripheral clocks by the peripheral clock control bits.	Set the core control bit SCR=0, set the wake-up conditions, and then execute _WFI () or _WFE ().	I/O or RTC or BAT or USB or ETH	1.15mA~1.5mA

Halt	The peripherals are powered normally; the core stops running; the clock system stops (PLL/HSE/HSI stops). You can select FlashROM to standby or stop.	Set the core control bit SCR=1, set the wake-up conditions, and then execute <code>_WFI()</code> or <code>_WFE()</code> .	I/O or RTC or BAT or USB or ETH	420uA~470uA
Sleep	The main LDO is off. The ultra-low-power ULP-LDO maintains the power supply of the PMU, the core, and basic peripherals. Users can select whether to turn on or off LSE or LSI and whether to maintain the power supply of RAM2K, RAM14K, USB, and RF configurations.	Set the core control bit SCR=1, set <code>POWER_PLAN</code> , set the wake-up conditions, and then execute <code>WFI()</code> or <code>WFE()</code> .	I/O or RTC or BAT. The chip will continue to run after wakeup.	0.6uA~2.6uA
Shutdown	The ultra-low-power LDO maintains the power supply of the PMU. Users can select whether to turn on LSE or LSI and whether to maintain the power supply of RAM2K and RAM14K for data retention.	Set the core control bit SCR=1, set <code>POWER_PLAN</code> , set the wake-up conditions, and then execute <code>WFI()</code> or <code>WFE()</code> .	I/O or RTC or BAT. The chip will automatically reset after wakeup.	0.2uA~1.5uA

The following table describes the detailed configurations of several low-power modes:

Table 5-3 Example of detailed configurations of low-power modes

Planning configuration	SYS_EN	RAM2K	RAM14K	CK32K	CORE	EXTEND	Power consumption (for reference only)
Function to maintain power supply	System power supply VSW	Data area 2KB	Data area 14KB	Either LSE or LSI, RTC wake-up	MO core and basic peripherals	USB and RF configurations	PMU and RTC registers are always powered, about 0.2uA
Common configurations of shutdown mode	0	0	0	0	0	0	0.2uA
	0	1	0	0	0	0	0.5uA~0.7uA
	0	0	0	1	0	0	0.5uA~0.6uA
	0	1	0	1	0	0	0.8uA~1.1uA
Common configurations of sleep mode	0	1	0	0	1	0	0.6uA~0.8uA
	0	1	0	1	1	0	0.9uA~1.2uA
	0	0	1	0	1	0	1.1uA~1.5uA
	0	0	1	1	1	0	1.4uA~1.9uA
	0	1	1	1	1	1	1.8uA~2.6uA

5.4 DC-DC operation procedures

Enable DC-DC power mode (Confirm the inductance and capacitance required by DC-DC on the external hardware circuit before enabling):

- (1) Enter safe access mode: Register R8_SAFE_ACCESS_SIG first writes 0x57 and then writes 0xA8;
- (2) Open the DC-DC bias circuit: Set RB_PWR_DCDC_PRE of Register R16_POWER_PLAN to 1;
- (3) Delay at least 10us;
- (4) Enter the safe access mode again: first write 0x57 into the register R8_SAFE_ACCESS_SIG and then write 0xA8;
- (5) Enable DC-DC power: Set RB_PWR_DCDC_EN of Register R16_POWER_PLAN to 1 to enable DC-DC.

Turn off DC-DC and switch to the pass-through mode:

- (1) Enter the safe access mode: first write 0x57 into the register R8_SAFE_ACCESS_SIG and then write 0xA8;
- (2) Reset the control bits of RB_PWR_DCDC_EN and RB_PWR_DCDC_PRE of Register R16_POWER_PLAN to zero.

Chapter 6 System Clock and RTC

6.1 System clock introduction

The following different clock sources can be selected to drive the system clock HCLK (Fsys)

- HSE or HSI original clock CK32M.
- Frequency division of HSE or HSI.
- Frequency division of internal PLL (480MHz at default).
- LSE or LSI original clock CK32K.

Any clock source can be independently turned on or off, thereby optimizing the power consumption of the system.

6.1.1 Clock structure

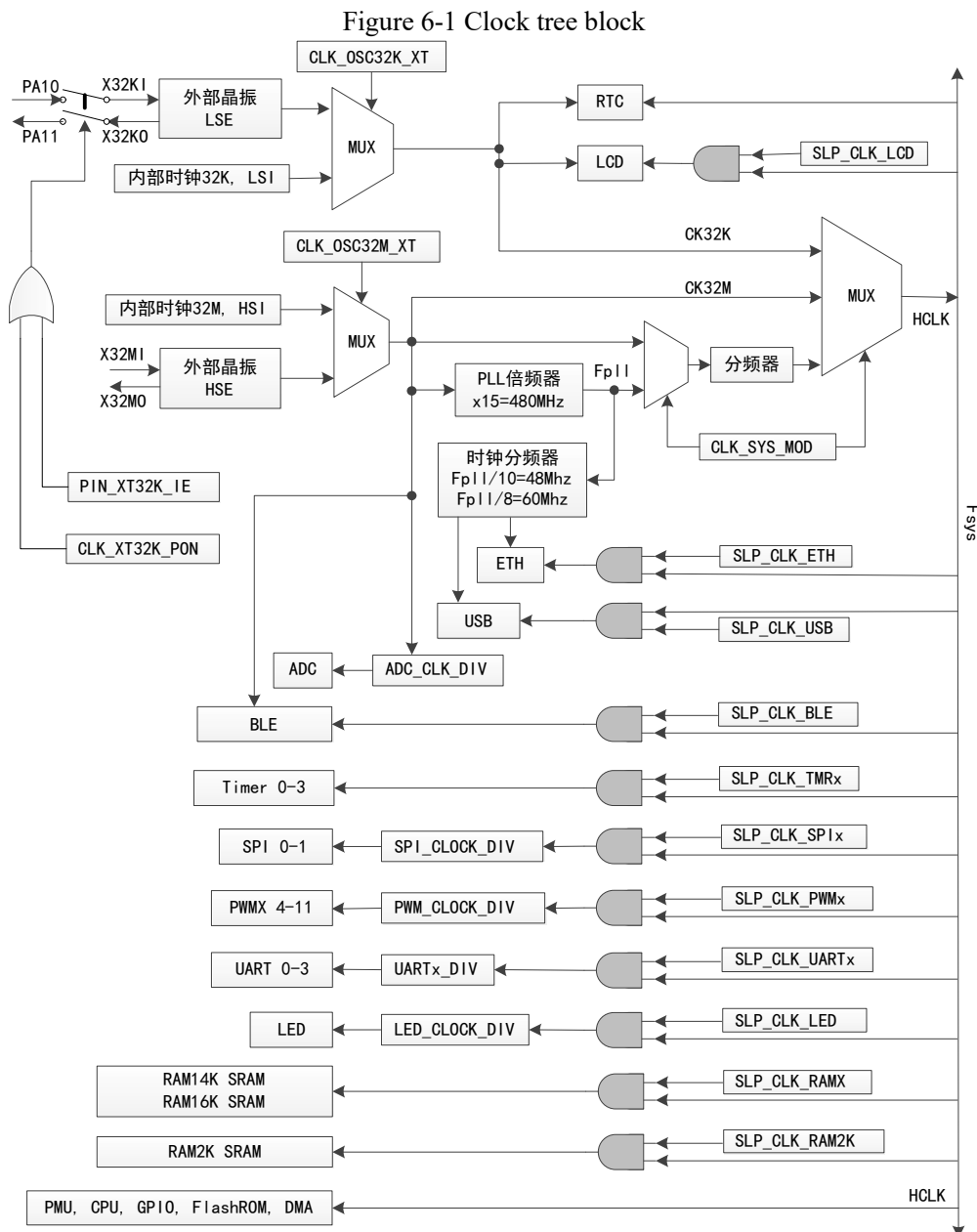

The figure above indicates the clock tree structure of the internal system. Specifically, the features of RTC and LCD use the 32KHz clock source CK32K, so the low frequency clock must be turned on when these features are used; the data transmission of USB and Ethernet depends on the clock source generated by the PLL frequency division; other peripheral drive clocks and digital control logic are driven by the system clock or by frequency re-division.

6.2 RTC instruction

Real Time Clock (RTC) is an independent timer that contains a set of counters counting continuously. The simple feature of calendar is available under the appropriate software configurations. The value of the counter is modified to reset the current time and date.

The RTC registers are powered as often as the PMU, and the RTC settings and time remain unchanged after a system reset or a wake-up from a low-power mode.

6.2.1 Main features

- 2 modes configurable:
 - Timing mode: The software can select a fixed cycle time (timing) to generate an interrupt notification.
 - Trigger mode: Match a software-preset target alarm time and generate an interrupt notification.
- 3 groups of 16-bit counters that provide the count of the CK32K original cycle, the 2 second cycle, and the 1-day cycle.

6.3 Register descriptions

Table 6-1 List of registers related to clock and oscillator control

Name	Access address	Description	Reset value
R16_CLK_SYS_CFG	0x40001008	System clock configuration register	0x05
R8_HFCK_PWR_CTRL	0x4000100A	High frequency clock module power control register	0x0C
R16_INT32K_TUNE	0x4000102C	Internal 32KHz clock calibration register	0x0200
R8_XT32K_TUNE	0x4000102E	External 32KHz clock resonance control register	0xC3
R8_CK32K_CONFIG	0x4000102F	32KHz oscillator configuration register	0XX2
R8_INT32M_CALIB	0x4000104C	Internal 32MHz clock calibration register	0XX
R8_XT32M_TUNE	0x4000104E	External 32MHz clock resonance control register	0x31
R16_OSC_CAL_CNT	0x40001050	Oscillator frequency calibration count value register	0XXXXX
R8_OSC_CAL_CTRL	0x40001052	Oscillator frequency calibration control register	0x02
R8_PLL_CONFIG	0x4000104B	PLL configuration register	0XX0
R8_RTC_FLAG_CTRL	0x40001030	RTC flag and control register	0x30
R8_RTC_MODE_CTRL	0x40001031	RTC mode configuration register	0x02
R32_RTC_TRIG	0x40001034	RTC trigger value register	0x00000000
R16_RTC_CNT_32K	0x40001038	RTC-based 32768Hz count value register	0XXXXXXXXX
R16_RTC_CNT_2S	0x4000103A	RTC count value register in the unit of 2s	0XXXXXXXXX
R32_RTC_CNT_DAY	0x4000103C	RTC count value register in the unit of day	0x0000XXXX

System Clock Configuration Register (R16_CLK_SYS_CFG)

Bit	Name	Access	Description	Reset value
15	RB_XO_DI	RO	Input state sample value of the X32MO pin.	0
[14:10]	Reserved	RO	Reserved	00000b
9	RB_CLK_OSC32M_XT	RWA	CK32M(32MHz) clock source selection bit: 1: External 32MHz oscillator; 0: Internal 32MHz oscillator.	0
8	Reserved	RO	Reserved	0
[7:6]	RB_CLK_SYS_MOD	RWA	HCLK system clock source mode selection: 00: CK32M (default 32MHz) for frequency division; 01: PLL (default 480MHz) for frequency division; 10: CK32M (default 32MHz) as HCLK; 11: CK32K (default 32KHz) as HCLK.	00b
5	Reserved	RO	Reserved	0
[4:0]	RB_CLK_PLL_DIV	RWA	HCLK output clock division factor, the minimum value is 2, 0 represents the maximum value 32. Write 1 to turn off HCLK.	00101b

Calculations:

$$F_{ck32m} = RB_CLK_OSC32M_XT ? XT_32MHz : RC_32MHz;$$

$F_{ck32k} = RB_CLK_OSC32K_XT ? XT_32KHz : RC_32KHz;$

$F_{pll} = F_{ck32m} * 15 = 480MHz;$

$F_{sys} = RB_CLK_SYS_MOD[1] ? (RB_CLK_SYS_MOD[0] ? F_{ck32k} : F_{ck32m}) :$

$((RB_CLK_SYS_MOD[0] ? F_{pll} : F_{ck32m}) / RB_CLK_PLL_DIV);$

Default power-on value $F_{sys} = F_{ck32m} / RB_CLK_PLL_DIV = 32MHz / 5 = 6.4MHz;$

F_{sys} range: 32KHz, 1MHz~16MHz, 32MHz, 15MHz~40MHz

High Frequency Clock Module Power Control Register (R8_HFCK_PWR_CTRL)

Bit	Name	Access	Description	Reset value
[7:6]	Reserved	RWA	Reserved. Must write 00.	00b
5	Reserved	RO	Reserved	0
4	RB_CLK_PLL_PON	RWA	PLL power control bit: 1: Power on; 0: Power down.	0
3	RB_CLK_INT32M_PON	RWA	Internal 32MHz oscillator power control bit: 1: Power on; 0: Power down.	1
2	RB_CLK_XT32M_PON	RWA	External 32MHz oscillator power control bit: 1: Power on; 0: Power down.	1
[1:0]	Reserved	RO	Reserved	00b

Internal 32KHz Clock Calibration Register (R16_INT32K_TUNE)

Bit	Name	Access	Description	Reset value
[15:10]	Reserved	RO	Reserved	000000b
[9:0]	RB_INT32K_TUNE	RWA	The calibration value of internal RC 32KHz clock frequency.	100000000b

External 32KHz Clock Resonance Control Register (R8_XT32K_TUNE)

Bit	Name	Access	Description	Reset value
[7:4]	RB_XT32K_C_LOAD	RWA	Choose a built-in load capacitor that matches the external 32KHz crystal (which may affect the accuracy of RTC clock): 0000: Built-in load capacity is 2pF; Other: Capacitance = RB_XT32K_C_LOAD + 12pF. 0001b~1111b correspond to approximately 13pF to 27pF, respectively. Choose according to the crystal parameters used.	1100b
[3:2]	Reserved	RO	Reserved	00b
[1:0]	RB_XT32K_I_TUNE	RWA	Select the bias current of the external 32KHz oscillator: 00: 70% of the rated current; 01: Rated current; 10: 140% of the rated current; 11: 200% of the rated current.	11b

32KHz Oscillator Configuration Register (R8_CK32K_CONFIG)

Bit	Name	Access	Description	Reset value
7	RB_32K_CLK_PIN	RO	32KHz clock pin status (asynchronous signal)	X
[6:3]	Reserved	RO	Reserved	0000b
2	RB_CLK_OSC32K_XT	RWA	CK32K (32KHz) clock source selection bit: 1: External 32KHz oscillator; 0: Internal 32KHz oscillator.	0
1	RB_CLK_INT32K_PON	RWA	Internal 32KHz oscillator power control bit: 1: Power on; 0: Power down.	1
0	RB_CLK_XT32K_PON	RWA	External 32KHz oscillator power control bit: 1: Power on; 0: Power down.	0

Internal 32MHz Clock Calibration Register (R8_INT32M_CALIB)

Bit	Name	Access	Description	Reset value
[7:0]	R8_INT32M_CALIB	RWA	Frequency calibration value of the internal RC 32MHz clock.	XXXXXXXXb

External 32MHz Clock Resonance Control Register (R8_XT32M_TUNE)

Bit	Name	Access	Description	Reset value
7	Reserved	RO	Reserved	0
[6:4]	RB_XT32M_C_LOAD	RWA	Select a built-in load capacitor that matches the external 32MHz crystal (possibly affecting wireless communication): Capacitance = RB_XT32M_C_LOAD* 2 + 10pF. 000b~111b correspond to approximately 10pF ~ 24pF respectively. Depending on the selected parameters of the crystal used, the commonly used value is 111b.	011b
[3:2]	Reserved	RO	Reserved	00b
[1:0]	RB_XT32M_I_BIAS	RWA	Select the bias current of the external 32MHz oscillator: 00: 75% of the rated current; 01: Rated current; 10: 125% of the rated current; 11: 150% of the rated current.	01b

Oscillator Frequency Calibration Counter Value Register (R16_OSC_CAL_CNT)

Bit	Name	Access	Description	Reset value
[15:12]	Reserved	RO	Reserved	0000b
[11:0]	RB_OSC_CAL_CNT	RO	The count value of five CK32K cycles based on the system main frequency and are used to calibrate the frequency of the internal 32KHz oscillator.	XXXh

Oscillator Frequency Calibration Control Register (R8_OSC_CAL_CTRL)

Bit	Name	Access	Description	Reset value
[7:2]	Reserved	RO	Reserved	000000b
1	RB_OSC_CNT_HALT	RO	Count status bit of oscillator frequency calibration counter: 1: Counting is being paused; 0: Counting is in progress.	1
0	RB_OSC_CNT_EN	RWA	Oscillator frequency calibration counter enable bit: 1: Enable counting; 0: Disable counting.	0

PLL Configuration Register (R8_PLL_CONFIG)

Bit	Name	Access	Description	Reset value
7	RB_PLL_LOCKED	RO	PLL lock status: 1: Locking; 0: Not locked currently.	X
[6:2]	Reserved	RO	Reserved	00000b
[1:0]	RB_PLL_CFG_DAT	RWA	PLL configuration parameters.	00b

RTC Flag and Control Register (R8_RTC_FLAG_CTRL)

Bit	Name	Access	Description	Reset value
7	RB_RTC_TRIG_FLAG	RO	Activation flag of RTC trigger mode.	0
6	RB_RTC_TMR_FLAG	RO	Activation flag of RTC timing mode.	0
5	RB_RTC_TRIG_CLR	RW	When the trigger mode is disabled, this bit is	1

			fixed as 1. When the trigger mode is enabled, write 1, clear the trigger mode activation flag RB_RTC_TRIG_FLAG, and automatically clear to 0.	
4	RB_RTC_TMR_CLR	RW	When the timing mode is disabled, this bit is fixed as 1. When the timing mode is enabled, write 1, clear the timing mode activation flag RB_RTC_TMR_FLAG, and automatically clear to 0.	1
[3:0]	Reserved	RO	Reserved	0000b

RTC Mode Configuration Register (R8_RTC_MODE_CTRL)

Bit	Name	Access	Description	Reset value
7	RB_RTC_LOAD_HI	RWA	Write 1 to load the high words of the RTC counter and automatically reset to zero after loading. Load R32_RTC_TRIG (actually only the lower 14 bits) into R32_RTC_CNT_DAY.	0
6	RB_RTC_LOAD_LO	RWA	Write 1 to load the low words of the RTC counter and automatically reset to zero after loading. Load the high 16 bits of R32_RTC_TRIG into R16_RTC_CNT_2S; load the low 16 bits of R32_RTC_TRIG into R16_RTC_CNT_32K.	0
5	RB_RTC_TRIG_EN	RWA	RTC Trigger Mode Enable Bit: 1: Enabled; 0: Disabled.	0
4	RB_RTC_TMR_EN	RWA	RTC Timing Mode Enable Bit: 1: Enabled; 0: Disabled.	0
3	RB_RTC_IGNORE_B0	RWA	Compare/ignore the lowest bit of the match value in trigger mode: 1: ignore the lowest bit; 0: compare the lowest bit.	0
[2:0]	RB_RTC_TMR_MODE	RWA	Select the fixed cycle (timing) of RTC timing mode: 000: 0.125S; 001: 0.25S; 010: 0.5S; 011: 1S; 100: 2S; 101: 4S; 110: 8S; 111: 16S.	010b

RTC Trigger Value Register (R32_RTC_TRIG)

Bit	Name	Access	Description	Reset value
[31:0]	R32_RTC_TRIG	RWA	Preset match values in the RTC trigger mode. The higher 16 bits and lower 16 bits match R16_RTC_CNT_2S and R16_RTC_CNT_32K, respectively. Match with RB_RTC_LOAD_LO and RB_RTC_LOAD_HI to update the current value of the RTC counter.	0000h

Note: The preset match values are not directly written into the target time. For simple calculations, please refer to the description below.

RTC-based 32768Hz Count Value Register (R16_RTC_CNT_32K)

Bit	Name	Access	Description	Reset value
[15:0]	R16_RTC_CNT_32K	RO	RTC-based 32768Hz count value register.	XXXXh

RTC Count Value Register in the Unit of 2S (R16_RTC_CNT_2S)

Bit	Name	Access	Description	Reset value
[15:0]	R16_RTC_CNT_2S	RO	The current count value of RTC in the unit of 2S.	XXXXh

RTC Count Value Register in the Unit of days (R32_RTC_CNT_DAY)

Bit	Name	Access	Description	Reset value
[31:16]	Reserved	RO	Reserved	0000h
[15:14]	Reserved	RO	Reserved	00b
[13:0]	R32_RTC_CNT_DAY	RO	The current count value of RTC in the unit of day.	XXXXXXXX XXXXXXXXb

6.4 Function description and configuration**6.4.1 RTC counter initialization**

- (1) Set the value of R32_RTC_TRIG register, and set RB_RTC_LOAD_HI to load the value of R32_RTC_TRIG register into R32_RTC_CNT_DAY Register;
- (2) Set the value of R32_RTC_TRIG register, and set RB_RTC_LOAD_LO to load the higher and lower 16-bit value of the R32_RTC_TRIG register to the R16_RTC_CNT_2S Register and the R16_RTC_CNT_32K Register respectively.

6.4.2 RTC clock source switched to LSE crystal

- (1) Confirm that the GPIO pins where X32KI and X32KO are located are not set as output, that no pull-up and pull-down resistors are set, that only crystals are set;
- (2) Configure R8_CK32K_CONFIG Register, set RB_CLK_XT32K_PON to 1, and turn on the external 32KHz crystal oscillator;
- (3) It is recommended to set RB_XT32K_I_TUNE to the maximum, wait for the crystal oscillator to stabilize (about several hundreds of mS), and then change to the rated current;
- (4) Configure the R8_CK32K_CONFIG register, set RB_CLK_OSC32K_XT to 1, and request to switch the clock source to the crystal oscillator;
- (5) Wait for at least half of the 32KHz clock cycle, usually 16uS, to actually complete the switching of clock sources.

6.4.3 RTC timing function

- (1) Configure the R8_RTC_MODE_CTRL register, set RB_RTC_TMR_MODE to select the appropriate timing cycle, set RB_RTC_TMR_EN to 1, and turn on the feature of RTC timing;
- (2) After the timing cycle is reached, the RTC timing activation flag of RB_RTC_TMR_FLAG and interrupt will be generated. Inquiry the R8_RTC_FLAG_CTRL register and set the RB_RTC_TMR_CLR to clear flag.

6.4.4 RTC trigger function

- (1) Set the target match values in the R32_RTC_TRIG Register. The steps of calculation and operation are: Calculate the target time value by adding the current time R32_RTC_CNT_32K(high 16 bits R16_RTC_CNT_2S and low 16 bits R16_RTC_CNT_32K) with DelayTime (in S), $T32 = R32_RTC_CNT_32K + DelayTime * 32768$,
If $(T32 \& 0xFFFF) \neq 0$, $T32 = T32 + 0x10000$,
Write T32 to the R32_RTC_TRIG register to complete the setting of match values.
- (2) Configure the R8_RTC_MODE_CTRL register, set RB_RTC_TRIG_EN to 1, and turn on the feature of RTC trigger;
- (3) When the current count values of RTC, R16_RTC_CNT_2S and R16_RTC_CNT_32K, match the preset high and low 16 bits of the R32_RTC_TRIG respectively, generate the RTC trigger activation flag RB_RTC_TRIG_FLAG and interrupt, and set the RB_RTC_TRIG_CLR to clear flag.
- (4) If the RTC has been over-calibrated, the target absolute time trigger can be supported. The target time value T32 is calculated based on the target year/month/day/hour/minute/second/millisecond. The other steps are the same as above. For details, please refer to the example program of evaluation board.

6.4.5 Calibrate the internal 32K clock LSI with HSE

Please refer to the example program of evaluation board.

Chapter 7 General-purpose I/O and Multiplexing Functions

7.1 GPIO introduction

The chip provides two sets of GPIO ports: PA and PB. There are a total of 40 general-purpose input and output pins, some of which have the features of interrupt, multiplexing and mapping.

Each GPIO port has a 32-bit direction configuration register R32_Px_DIR, a 32-bit pin input register R32_Px_PIN, a 32-bit data output register R32_Px_OUT, a 32-bit data reset register R32_Px_CLR, a 32-bit pull-up resistor configuration register R32_Px_PU and a 32-bit register R32_Px_PD_DRV with pull-down resistor/drive capability configurations.

In PA ports, PA[0]~PA[15] bits are valid, corresponding to 16 GPIO pins on the chip. In PB ports, PB[0]~PB[23] bits are valid, corresponding to 24 GPIO pins on the chip. Among them, 32 I/O pins, PA[0]~PA[15] and PB[0]~PB[15], have interrupt feature and can realize the feature of wakeup from sleep.

Each I/O port bit is freely programmable, but the I/O port registers must be accessed by 8-bit, 16-bit or 32-bit words. If the pin multiplexing feature is not enabled, it is used by default as a general purpose I/O port.

The following is the block diagram of the internal GPIO structure:

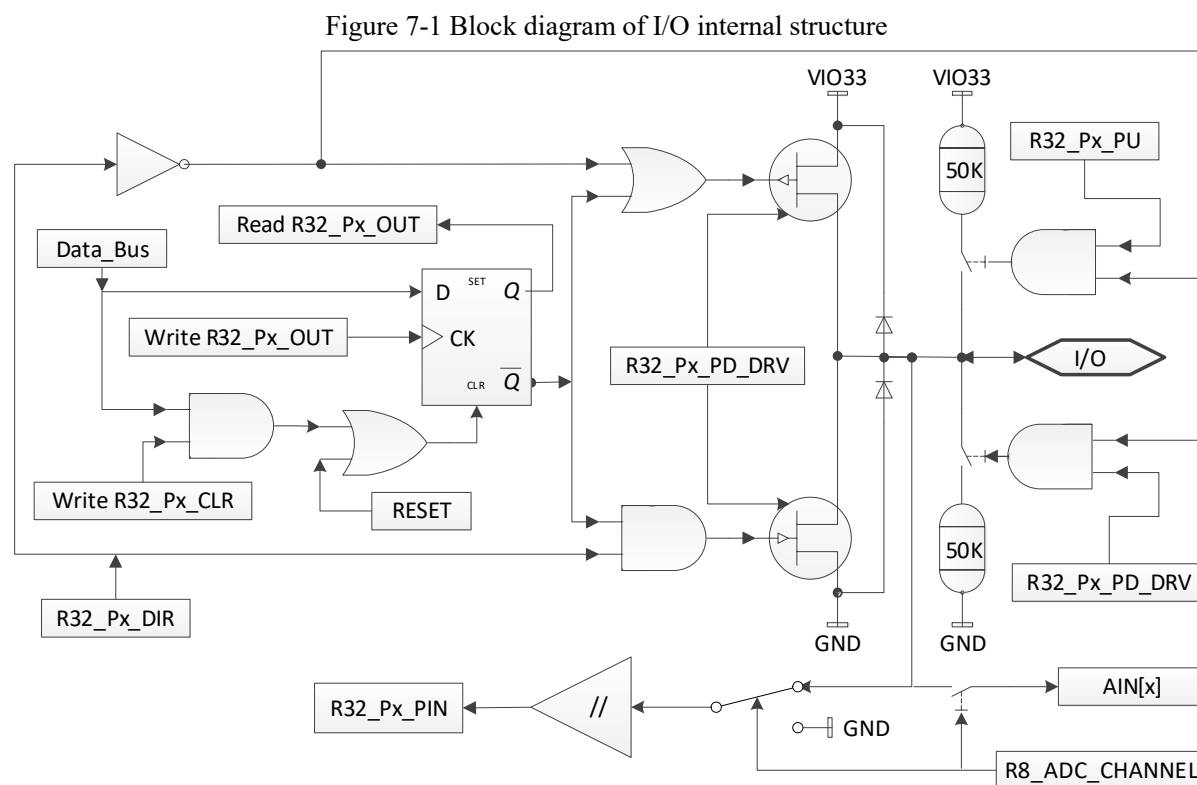

7.2 External interrupt/wakeup

32 I/O pins (PA[0]~PA[15], PB[0]~PB[15]) on chip have the feature of interrupt and can realize sleep wake-up.

In order to use an external interrupt, the port bits must be configured as the input mode. Four trigger modes are available: high level, low level, rising edge, and falling edge.

The wake-up feature requires the port bit interrupt to enable R16_Px_INT_EN and turn on the GPIO wake-up control bit RB_SLP_GPIO_WAKE in the register R8_SLP_WAKE_CTRL.

7.3 GPIO Multiplexing and Remapping

7.3.1 Multiplexing functions

Some I/O pins have the feature of multiplexing. By default, all I/O pins have the general-purpose I/O feature after power-on. After each feature module is enabled, the corresponding original GPIO pins are configured as feature pins corresponding to their respective feature module.

If a pin multiplexes multiple features that have been enabled, the priority order of the multiplexing feature can refer to the sequence of features as described in Section 1.2 of "Multiplexing".

For example, if the PA0 pin is multiplexed to SCK1/SLVA/LED0, the clock feature of SPI1 takes precedence, and the feature of serial data output 0 of the LED screen interface ranks the lowest. In this way, among multiple multiplexing features, pins that do not need to be used and have the lowest priority of feature are enabled with multiplexing feature at a relatively higher priority.

The following table lists some of the GPIO configurations used for the feature pins of the peripheral modules.

Table 7-1 Timer x

TMR0/1/2/3 pin	Feature configuration	GPIO configuration
TMRx	Input capture channel x	Input (floating input / pull-up input / pull-down input)
	Output PWM channel x	Push-pull output

Table 7-2 UARTx

UART0/1/2/3 pin	Feature configuration	GPIO configuration
TXDx	UART transmitter x	Push-pull output
RXDx	UART receiver x	Pull-up input (recommended) or floating input
RTS, DTR	MODEM signal output or RS485 control	Push-pull output
CTS, DSR, RI, DCD	MODEM signal input	Pull-up input (recommended) or floating input

Table 7-3 SPIx

SPI0/1 pin	Feature configuration	GPIO configuration
SCKx	Clock output in master mode	Push-pull output
	Clock input in slave mode	Input (floating input / pull-up input / pull-down input)
MOSIx	Full duplex mode - master mode	Push-pull output
	Full duplex mode - slave mode	Input (floating input / pull-up input / pull-down input)
	Half-duplex mode - master mode	Not used. Can be used as general purpose I/O
	Half-duplex mode - slave mode	Not used. Can be used as general purpose I/O
MISOx	Full duplex mode - master mode	Input (floating input / pull-up input / pull-down input)
	Full-duplex mode - slave mode	Input (pull-up recommended; automatically switch to push-pull output after chip selection) or push-pull output (disabled for bus connection)
	Half-duplex mode - master mode	Input or push-pull output, manual switching
	Half-duplex mode - slave mode	Input (pull-up recommended; automatically switch to push-pull output after chip selection)
SCS	Chip selection output in master mode	Push-pull output (can be replaced with other pins)
	Chip selection input in slave mode	Pull-up input (recommended) or floating input

Table 7-4 ADC

ADC sampling channel pin	Feature configuration	GPIO configuration
AINx	Analog to digital conversion input channel	Floating input

Table 7-5 USB

USB signal pin	Feature configuration	GPIO configuration
USB_DM	Connect to internal USB transceiver	Floating input

USB_DP	Connect to internal USB transceiver	Floating input
--------	-------------------------------------	----------------

Table 7-6 Ethernet

Ethernet signal pin	Feature configuration	GPIO configuration
ET+/ET-	Connect to an internal Ethernet transceiver	Floating input
ER+/ER-	Connect to an internal Ethernet transceiver	Floating input

7.3.2 Remapping of function pins

In order to enable the peripheral functions and optimize the utilization rate at the same time, some function pins can be remapped to other pins by setting the R16_PIN_ALTERNATE feature pin remapping register.

Table 7-7 Multiplexing function remapped to pins

Peripheral function pins	Default GPIO pins	Remapped GPIO pins
SPI0	PA[12]/PA[13]/PA[14]/PA[15]	PB[12]/PB[13]/PB[14]/PB[15]
RXD3/TXD3	PA[4]/PA[5]	PB[20]/PB[21]
RXD2/TXD2	PA[6]/PA[7]	PB[22]/PB[23]
RXD1/TXD1	PA[8]/PA[9]	PB[8]/PB[9]
RXD0/TXD0	PB[4]/PB[7]	PA[15]/PA[14]
TMR3/PWM3/CAP3	PA[2]	PB[18]
TMR2/PWM2/CAP2	PA[11]	PB[11]
TMR1/PWM1/CAP1	PA[10]	PB[10]
TMR0/PWM0/CAP0	PA[3]	PB[19]

7.4 Register description

Name	Access address	Description	Reset value
R16_PIN_ALTERNATE	0x40001018	Feature pin remapping register	0x0000
R16_PIN_ANALOG_IE	0x4000101A	Peripheral analog pin configuration register	0x0000
R16_PA_INT_EN	0x40001090	PA port interrupt enable register	0x0000
R16_PB_INT_EN	0x40001092	PB port interrupt enable register	0x0000
R16_PA_INT_MODE	0x40001094	PA port interrupt mode configuration register	0x0000
R16_PB_INT_MODE	0x40001096	PB port interrupt mode configuration register	0x0000
R16_PA_INT_IF	0x4000109C	PA port interrupt flag register	0x0000
R16_PB_INT_IF	0x4000109E	PB port interrupt flag register	0x0000
R32_PA_DIR	0x400010A0	PA port direction configuration register	0x00000000
R32_PA_PIN	0x400010A4	PA port pin input register	0x0000XXXX
R32_PA_OUT	0x400010A8	PA port data output register	0x00000000
R32_PA_CLR	0x400010AC	PA port data reset register	0x00000000
R32_PA_PU	0x400010B0	PA port pull-up resistor configuration register	0x00000000
R32_PA_PD_DRV	0x400010B4	PA port pull-down/drive configuration register	0x00000000
R32_PB_DIR	0x400010C0	PB port direction configuration register	0x00000000
R32_PB_PIN	0x400010C4	PB port pin input register	0x00XXXXXX
R32_PB_OUT	0x400010C8	PB port data output register	0x00000000
R32_PB_CLR	0x400010CC	PB port data reset register	0x00000000
R32_PB_PU	0x400010D0	PB port pull-up resistor configuration register	0x00000000
R32_PB_PD_DRV	0x400010D4	PB port pull-down/drive configuration register	0x00000000

Feature Pin Remapping Register (R16 PIN ALTERNATE)

Bit	Name	Access	Description	Reset value
[15:12]	Reserved	RO	Reserved	0000b
[11:9]	Reserved	RO	Reserved	000b
8	RB_PIN_SPI0	RW	SPI0 feature pin mapping select bit: 1: SCK0_/SCS_/MOSI_/MISO_ is mapped to PB[12]/PB[13]/PB[14]/PB[15]; 0: SCK0/SCS/MOSI/MISO is mapped to PA[12]/PA[13]/PA[14]/PA[15].	0
7	RB_PIN_UART3	RW	UART3 feature pin mapping select bit: 1: RXD3_/TXD3_ is mapped to PB[20]/PB[21]; 0: RXD3/TXD3 is mapped to PA[4]/PA[5].	0
6	RB_PIN_UART2	RW	UART2 feature pin mapping select bit: 1: RXD2_/TXD2_ is mapped to PB[22]/PB[23]; 0: RXD2/TXD2 is mapped to PA[6]/PA[7].	0
5	RB_PIN_UART1	RW	UART1 feature pin mapping select bit: 1: RXD1_/TXD1_ is mapped to PB[8]/PB[9]; 0: RXD1/TXD1 is mapped to PA[8]/PA[9].	0
4	RB_PIN_UART0	RW	UART0 feature pin mapping select bit: 1: RXD0_/TXD0_ is mapped to PA[15]/PA[14]; 0: RXD0/TXD0 is mapped to PB[4]/PB[7].	0
3	RB_PIN_TMR3	RW	TMR3 feature pin mapping select bit: 1: TMR3_/PM3_/CAP3_ is mapped to PB[18]; 0: TMR3/PWM3/CAP3 is mapped to PA[2].	0
2	RB_PIN_TMR2	RW	TMR2 feature pin mapping select bit: 1: TMR2_/PM2_/CAP2_ is mapped to PB[11]; 0: TMR2/PWM2/CAP2 is mapped to PA[11].	0
1	RB_PIN_TMR1	RW	TMR1 feature pin mapping select bit: 1: TMR1_/PWM1_/CAP1_ is mapped to PB[10]; 0: TMR1/PWM1/CAP1 is mapped to PA[10].	0
0	RB_PIN_TMR0	RW	TMR0 feature pin mapping select bit: 1: TMR0_/PWM0_/CAP0_ is mapped to PB[19]; 0: TMR0/PWM0/CAP0 is mapped to PA[3].	0

Peripheral Analog Pin Configuration Register (R16 PIN ANALOG IE)

Bit	Name	Access	Description	Reset value
15	RB_PIN_ADC4_5_IE	RW	ADC/TKEY 4/5 Channel Pin Digital Input Disabled: 1: Turn off the PA14-15 digital input to save power; 0: Turn on the digital input.	0
14	RB_PIN_ADC2_3_IE	RW	ADC/TKEY 2/3 Channel Pin Digital Input Disabled: 1: Turn off the PA12-13 digital input to save power; 0: Turn on the digital input.	0
13	RB_PIN_XT32K_IE	RW	32KHz Crystal LSE Pin Digital Input Disabled: 1: Turn off the PA10-11 digital input to save power; 0: Turn on the digital input.	0
12	RB_PIN_ADC12_13_IE	RW	ADC/TKEY 12/13 Channel Pin Digital Input Disabled: 1: Turn off the PA8-9 digital input to save power;	0

			0: Turn on the digital input.	
11	RB_PIN_ADC10_11_IE	RW	ADC/TKEY 10/11 Channel Pin Digital Input Disabled: 1: Turn off the PA6-7 digital input to save power; 0: Turn on the digital input.	0
10	RB_PIN_ADC0_1_IE	RW	ADC/TKEY 0/1 Channel Pin Digital Input Disabled: 1: Turn off the PA4-5 digital input to save power; 0: Turn on the digital input.	0
9	RB_PIN_ADC6_7_IE	RW	ADC/TKEY 7/6 Channel Pin Digital Input Disabled: 1: Turn off the PA2-3 digital input to save power; 0: Turn on the digital input.	0
8	RB_PIN_ADC8_9_IE	RW	ADC/TKEY 9/8 Channel Pin Digital Input Disabled: 1: Turn off the PA0-1 digital input to save power; 0: Turn on the digital input.	0
7	RB_PIN_USB_IE	RW	USB Pin Enabled: 1: PB10-11 are USB communication pins; 0: PB10-11 are not used for USB communication.	0
6	RB_PIN_ETH_IE	RW	ETH Pin Enabled: 1: PB12-15 are the ETH communication pins. If LCD is not enabled entirely, RB_PIN_SEG12_15_IE can be set to 1 to turn off the digital input, which can save power. 0: PB12-15 are not used for ETH communication.	0
5	RB_PIN_SEG20_23_IE	RW	LCD 20-23 Segment Pin Enabled/Digital Input Disabled: 1: PB20-23 are segment drive. Turn off the digital input; 0: Turn on the digital input and turn off the LCD segment drive.	0
4	RB_PIN_SEG16_19_IE	RW	LCD 16-19 Segment Pin Enable/Digital Input Disabled: 1: PB16-19 are segment drive. Turn off the digital input; 0: Turn on the digital input and turn off the LCD segment drive.	0
3	RB_PIN_SEG12_15_IE	RW	LCD 12-15 Segment Pin Enable/Digital Input Disabled: 1: PB12-15 are segment drive. Turn off the digital input; 0: Turn on the digital input and turn off the LCD segment drive.	0
2	RB_PIN_SEG8_11_IE	RW	LCD 8-11 Segment Pin Enable/Digital Input Disabled: 1: PB8-11 are segment drive. Turn off digital input; 0: Turn on the digital input and turn off the LCD segment drive.	0
1	RB_PIN_SEG4_7_IE	RW	LCD 4-7 Segment Pin Enabled / Digital Input Disabled: 1: PB4-7 are segment drive. Turn off the digital input; 0: Turn on the digital input and turn off the LCD	0

			segment drive.	
0	RB_PIN_SEG0_3_IE	RW	LCD 0-3 Segment Pin Enabled/Digital Input Disabled: 1: PB0-3 are segment drive. Turn off the digital input; 0: Turn on the digital input and turn off the LCD segment drive.	0

Note: If a pin is used for analog feature (ADC/TouchKey/ETH), it is recommended to turn off the digital input feature of this pin (that is, set the digital input as disabled), thereby reducing power consumption and facilitating to reduce interference.

PA Port Interrupt Enable Register (R16_PA_INT_EN)

Bit	Name	Access	Description	Reset value
[15:0]	R16_PA_INT_EN	RW	PA pin interrupt enable bit: 1: Enable the corresponding interrupt; 0: Disable the corresponding interrupt.	0000h

PB Port Interrupt Enable Register (R16_PB_INT_EN)

Bit	Name	Access	Description	Reset value
[15:0]	R16_PB_INT_EN	RW	PA pin interrupt enable bit: 1: Enable the corresponding interrupt; 0: Disable the corresponding interrupt.	0000h

PA Port Interrupt Mode Configuration Register (R16_PA_INT_MODE)

Bit	Name	Access	Description	Reset value
[15:0]	R16_PA_INT_MODE	RW	PA pin interrupt mode selection bit: 1: Edge trigger; 0: Level trigger.	0000h

PB Port Interrupt Mode Configuration Register (R16_PB_INT_MODE)

Bit	Name	Access	Description	Reset value
[15:0]	R16_PB_INT_MODE	RW	PB pin interrupt mode selection bit: 1: Edge trigger; 0: Level trigger.	0000h

PA Port Interrupt Flag Register (R16_PA_INT_IF)

Bit	Name	Access	Description	Reset value
[15:0]	R16_PA_INT_IF	RW1	PA pin interrupt flag bit. Write 1 and reset to zero: 1: Interrupted; 0: No interrupt.	0000h

PB Port Interrupt Flag Register (R16_PB_INT_IF)

Bit	Name	Access	Description	Reset value
[15:0]	R16_PB_INT_IF	RW1	PB pin interrupt flag bit. Write 1 and reset to zero: 1: Interrupted; 0: No interrupt.	0000h

PA Port Direction Configuration Register (R32_PA_DIR)

Bit	Name	Access	Description	Reset value
[31:16]	Reserved	RO	Reserved	0000h
[15:8]	R8_PA_DIR_1	RW	Configure the current input and output direction of PA pin: 1: The pin is in the output mode; 0: The pin is in the input mode.	00h
[7:0]	R8_PA_DIR_0	RW		00h

PA Port Pin Input Register (R32_PA_PIN)

Bit	Name	Access	Description	Reset value
[31:16]	Reserved	RO	Reserved	0000h
[15:8]	R8_PA_PIN_1	RO	The current level status of PA pin (this bit value is valid only when the corresponding bit of R32_PA_DIR is 0): 1: Pin input is at the high level; 0: Pin input is at the low level.	XXh
[7:0]	R8_PA_PIN_0	RO		XXh

PA Port Data Output Register (R32_PA_OUT)

Bit	Name	Access	Description	Reset value
[31:16]	Reserved	RO	Reserved	0000h
[15:8]	R8_PA_OUT_1	RW	When the corresponding bit of direction register R32_PA_DIR is 1: Control the level status of PA pin output: 1: Output at high level; 0: Output at low level. When the corresponding bit of direction register R32_PA_DIR is 0: Control the interrupt polarity selection of PA pin: 1: High level/rising edge; 0: Low level/falling edge.	00h
[7:0]	R8_PA_OUT_0	RW		00h

PA Port Data Reset Register (R32_PA_CLR)

Bit	Name	Access	Description	Reset value
[31:16]	Reserved	RO	Reserved	0000h
[15:8]	R8_PA_CLR_1	WZ	PA data register reset control: 1: The corresponding bit data of R32_PA_OUT is reset to 0; 0: No effect.	00h
[7:0]	R8_PA_CLR_0	WZ		00h

PA Port Pull-up Resistor Configuration Register (R32_PA_PU)

Bit	Name	Access	Description	Reset value
[31:16]	Reserved	RO	Reserved	0000h
[15:8]	R8_PA_PU_1	RW	PA pin pull-up resistor enable control: 1: Turn on pull-up resistor; 0: Turn off pull-up resistor.	00h
[7:0]	R8_PA_PU_0	RW		00h

PA Port Pull-down/Drive Configuration Register (R32_PA_PD_DRV)

Bit	Name	Access	Description	Reset value
[31:16]	Reserved	RO	Reserved	0000h
[15:8]	R8_PA_PD_DRV_1	RW	When the corresponding bit of direction register R32_PA_DIR is 0: PA pin pull-down resistor enable control: 1: Turn on pull-down resistor; 0: Turn off pull-down resistor. When the corresponding bit of direction register R32_PA_DIR is 1: Select PA pin current drive capability: 1: 20mA level; 0: 5mA level.	00h
[7:0]	R8_PA_PD_DRV_0	RW		00h

PB Port Direction Configuration Register (R32_PB_DIR)

Bit	Name	Access	Description	Reset value
[31:24]	Reserved	RO	Reserved	00h

[23:16]	R8_PB_DIR_2	RW	Configure the current input and output direction of PB pin: 1: The pin is in the output mode; 0: The pin is in the input mode.	00h
[15:8]	R8_PB_DIR_1	RW		00h
[7:0]	R8_PB_DIR_0	RW		00h

PB Port Pin Input Register (R32_PB_PIN)

Bit	Name	Access	Description	Reset value
[31:24]	Reserved	RO	Reserved	00h
[23:16]	R8_PB_PIN_2	RO	The current level status of PB pin (this bit value is valid only when the corresponding bit of R32_PB_DIR is 0): 1: Pin input is at the high level; 0: Pin input is at the low level.	XXh
[15:8]	R8_PB_PIN_1	RO		XXh
[7:0]	R8_PB_PIN_0	RO		XXh

PB Port Data Output Register (R32_PB_OUT)

Bit	Name	Access	Description	Reset value
[31:24]	Reserved	RO	Reserved	00h
[23:16]	R8_PB_OUT_2	RW	When the corresponding bit of direction register R32_PB_DIR is 1: Control the level status of PB pin output: 1: Output high level; 0: Output low level.	00h
[15:8]	R8_PB_OUT_1	RW	When the corresponding bit of direction register R32_PB_DIR is 1: Control the level status of PB pin output: 1: Output high level; 0: Output low level.	00h
[7:0]	R8_PB_OUT_0	RW	When the corresponding bit of direction register R32_PB_DIR is 0: Control the interrupt polarity selection of PB pin: 1: High level /rising edge; 0: Low level/falling edge.	00h

PB Port Data Reset Register (R32_PB_CLR)

Bit	Name	Access	Description	Reset value
[31:24]	Reserved	RO	Reserved	00h
[23:16]	R8_PB_CLR_2	WZ	PB data register reset control: 1: The corresponding bit data of R32_PB_OUT is reset to 0; 0: No effect.	00h
[15:8]	R8_PB_CLR_1	WZ		00h
[7:0]	R8_PB_CLR_0	WZ		00h

PB Port Pull-up Resistor Configuration Register (R32_PB_PU)

Bit	Name	Access	Description	Reset value
[31:24]	Reserved	RO	Reserved	00h
[23:16]	R8_PB_PU_2	RW	Control PB pin pull-up resistor enable: 1: Turn on pull-up resistor; 0: Turn off pull-up resistor.	00h
[15:8]	R8_PB_PU_1	RW		00h
[7:0]	R8_PB_PU_0	RW		00h

PB Port Pull-down/Drive Configuration Register (R32_PB_PD_DRV)

Bit	Name	Access	Description	Reset value
[31:24]	Reserved	RO	Reserved	00h
[23:16]	R8_PB_PD_DRV_2	RW	When the corresponding bit of direction register R32_PB_DIR is 0: Control PB pin pull-down resistor enable: 1: Turn on pull-down resistor; 0: Turn off pull-down resistor.	00h
[15:8]	R8_PB_PD_DRV_1	RW		00h
[7:0]	R8_PB_PD_DRV_0	RW		When the corresponding bit of direction register R32_PB_DIR is 1:

			Select the drive capability of PB pin current: 1: 20mA level; 0: 5mA level.	
--	--	--	--	--

7.5 GPIO pin mode configuration

Each GPIO can be configured into 5 modes, as indicated in the following table:

Table 7-9 Port configuration

Mode	R32 Px DIR	R32 Px PU	R32 Px PD_DRV
Floating input/ high-resistance input / analog input	0	0	0
Input with pull-up resistor	0	1	0
Input with pull-down resistor	0	0	1
Push-pull output, 5mA level drive capability	1	X	0
Push-pull output, 20mA level drive capability	1	X	1

Chapter 8 General Purpose Timer (TMRx)

8.1 TMRx introduction

A chip is provided with four 26-bit timers: TMR0, TMR1, TMR2, and TMR3, with a maximum timing of 2^{26} clock cycles. It is applicable to a variety of circumstances, including measuring the pulse length of input signal (input capture) or generating an output waveform (PWM). In addition, TMR1 and TMR2 support the feature of DMA. Each timer is completely independent and can be synchronously operated together.

8.1.1 Main feature

- Four 26-bit timers: each timer has a maximum timing of 2^{26} clock cycles.
- Support timer interrupts, in addition, TMR1 and TMR2 support DMA and interrupts.
- Support the feature of capture and measurement of length or cycle of input pulse.
- The feature of capture can be set to be capture of level change and hold time of high or low level.
- Support 26-bit PWM and adjust the duty ratio of PWM dynamically.

8.2 Register description

Table 8-1 List of TMR0-related registers

Name	Access address	Description	Reset value
R8_TMR0_CTRL_MOD	0x40002000	Mode setting register	0x02
R8_TMR0_INTER_EN	0x40002002	Interrupt enable register	0x00
R8_TMR0_INT_FLAG	0x40002006	Interrupt flag register	0x00
R8_TMR0_FIFO_COUNT	0x40002007	FIFO count register	0x0X
R32_TMR0_COUNT	0x40002008	Current count value register	0x0XXXXXXXX
R32_TMR0_CNT_END	0x4000200C	Count final value setting register	0x0XXXXXXXX
R32_TMR0_FIFO	0x40002010	FIFO register	0x0XXXXXXXX

Table 8-2 List of TMR1-related registers

Name	Access address	Description	Reset value
R8_TMR1_CTRL_MOD	0x40002400	Mode setting register	0x02
R8_TMR1_CTRL_DMA	0x40002401	DMA control register	0x00
R8_TMR1_INTER_EN	0x40002402	Interrupt enable register	0x00
R8_TMR1_INT_FLAG	0x40002406	Interrupt flag register	0x00
R8_TMR1_FIFO_COUNT	0x40002407	FIFO count register	0x0X
R32_TMR1_COUNT	0x40002408	Current count value register	0x0XXXXXXXX
R32_TMR1_CNT_END	0x4000240C	Count final value register	0x0XXXXXXXX
R32_TMR1_FIFO	0x40002410	FIFO register	0x0XXXXXXXX
R16_TMR1_DMA_NOW	0x40002414	DMA current buffer zone address	0x0000XXXX
R16_TMR1_DMA_BEG	0x40002418	DMA start buffer zone address	0x0000XXXX
R16_TMR1_DMA_END	0x4000241C	DMA end buffer zone address	0x0000XXXX

Table 8-3 List of TMR2-related registers

Name	Access address	Description	Reset value
R8_TMR2_CTRL_MOD	0x40002800	Mode setting register	0x02
R8_TMR2_CTRL_DMA	0x40002801	DMA control register	0x00

R8_TMR2_INTER_EN	0x40002802	Interrupt enable register	0x00
R8_TMR2_INT_FLAG	0x40002806	Interrupt flag register	0x00
R8_TMR2_FIFO_COUNT	0x40002807	FIFO count register	0x0X
R32_TMR2_COUNT	0x40002808	Current count value register	0x0XXXXXXXX
R32_TMR2_CNT_END	0x4000280C	Count final value register	0x0XXXXXXXX
R32_TMR2_FIFO	0x40002810	FIFO register	0x0XXXXXXXX
R16_TMR2_DMA_NOW	0x40002814	DMA current buffer zone address	0x0000XXXX
R16_TMR2_DMA_BEG	0x40002818	DMA start buffer zone address	0x0000XXXX
R16_TMR2_DMA_END	0x4000281C	DMA end buffer zone address	0x0000XXXX

Table 8-4 List of TMR3-related registers

Name	Access address	Description	Reset value
R8_TMR3_CTRL_MOD	0x40002C00	Mode setting register	0x02
R8_TMR3_INTER_EN	0x40002C02	Interrupt enable register	0x00
R8_TMR3_INT_FLAG	0x40002C06	Interrupt flag register	0x00
R8_TMR3_FIFO_COUNT	0x40002C07	FIFO count register	0x0X
R32_TMR3_COUNT	0x40002C08	Current count value register	0x0XXXXXXXX
R32_TMR3_CNT_END	0x40002C0C	Count final value setting register	0x0XXXXXXXX
R32_TMR3_FIFO	0x40002C10	FIFO register	0x0XXXXXXXX

Mode Setting Register (R8_TMRx_CTRL_MOD) (x=0/1/2/3)

Bit	Name	Access	Description	Reset value
[7:6]	RB_TMR_CAP_EDGE	RW	In capture mode, select the capture trigger mode: 00: No trigger; 01: Capture the time between any edge changes; 10: Capture the time between the falling edge and the falling edge; 11: Capture the time between the rising edge and the rising edge. In count mode, select the count edge: 00: Not sample count; 01: Sample count to any edge; 10: Sample count to the falling edge; 11: Sample count to the rising edge.	00b
[7:6]	RB_TMR_PWM_REPEAT	RW	In PWM mode, select the data duplication mode: 00: Repeat 1 time; 01: Repeat 4 times; 10: Repeat 8 times; 11: Repeat 16 times.	00b
5	Reserved	RO	Reserved	0
4	RB_TMR_CAP_COUNT	RW	Sub-mode of RB_TMR_MODE_IN=1 input mode: 1: Count mode; 0: Capture mode.	0
4	RB_TMR_OUT_POLAR	RW	In PWM mode, output polarity setting bit: 1: Default at high level, active at low level; 0: Default at low level, active at high level.	0
3	RB_TMR_OUT_EN	RW	Timer output enable bit: 1: Output enabled; 0: Output disabled.	0

2	RB_TMR_COUNT_EN	RW	Timer count enable bit: 1: Enable counting; 0: Disable counting.	0
1	RB_TMR_ALL_CLEAR	RW	Timer's FIFO/counter/interrupt flag cleared: 1: Force emptying and clearing; 0: No clearing.	1
0	RB_TMR_MODE_IN	RW	Timer mode setting bit: 1: Input mode (capture mode or counting mode); 0: Timing mode or PWM mode.	0

Interrupt Enable Register (R8_TMRx_INTER_EN) (x=0/1/2/3)

Bit	Name	Access	Description	Reset value
[7:5]	Reserved	RO	Reserved	000b
4	RB_TMR_IE_FIFO_OV	RW	FIFO Overflow (FIFO full in capture mode or FIFO empty in PWM mode) Interrupt Enable Bit: 1: Enable interrupt; 0: Disable interrupt.	0
3	RB_TMR_IE_DMA_END	RW	DMA End Interrupt Enable bit (TMR1/2 support only): 1: Enable interrupt; 0: Disable interrupt.	0
2	RB_TMR_IE_FIFO_HF	RW	FIFO Used More Than Half (FIFO \geq 4 in capture mode or FIFO $<$ 4 in PWM mode) Interrupt Enable Bit: 1: Enable interrupt; 0: Disable interrupt.	0
1	RB_TMR_IE_DATA_ACT	RW	Data Activation (it means that every time new data is captured in capture mode, and it means that value triggers the end of the active level in PWM mode) Interrupt Enable Bit: 1: Enable interrupt; 0: Disable interrupt.	0
0	RB_TMR_IE_CYC_END	RW	Cycle End (it refers to timeout in capture mode, and it refers to the end of the cycle in PWM mode and timing mode) Interrupt Enable Bit: 1: Enable interrupt; 0: Disable interrupt.	0

Interrupt Flag Register (R8_TMRx_INT_FLAG) (x=0/1/2/3)

Bit	Name	Access	Description	Reset value
[7:5]	Reserved	RO	Reserved	000b
4	RB_TMR_IF_FIFO_OV	RW1	FIFO overflow (FIFO full in capture mode or FIFO empty in PWM mode) flag bit. Write 1 to reset: 1: Has overflowed; 0: No overflow.	0
3	RB_TMR_IF_DMA_END	RW1	DMA completion flag bit. Write 1 to reset: 1: Completed; 0: Not completed.	0
2	RB_TMR_IF_FIFO_HF	RW1	FIFO used more than half (FIFO \geq 4 in capture mode or FIFO $<$ 4 in PWM mode) flag bit. Write 1 to reset: 1: FIFO has been used more than half; 0: The FIFO has not been used more than half.	0
1	RB_TMR_IF_DATA_ACT	RW1	Data activation (it means that each time new data is captured in capture mode. And it means that value triggers the end of the active level in PWM mode) flag bit. Write 1 to reset: 1: Generated/used data; 0: Not generated/not used.	0

0	RB_TMR_IF_CYC_END	RW1	Cycle end (it refers to timeout in capture mode, and it refers to the end of the cycle in PWW mode and timing mode) flag bit. Write 1 to reset: 1: Timeout/cycle end; 0: No timeout/not ended.	0
---	-------------------	-----	---	---

FIFO Count Register (R8_TMRx_FIFO_COUNT) (x=0/1/2/3)

Bit	Name	Access	Description	Reset value
[7:0]	R8_TMRx_FIFO_COUNT	RO	Data count in FIFO. The maximum value is 8.	0x0X

Current Count Value Register (R32_TMRx_COUNT) (x=0/1/2/3)

Bit	Name	Access	Description	Reset value
[31:0]	R32_TMRx_COUNT	RO	The current count value of the counter.	0XXXXXXXXh

Final Count Value Setting Register (R32_TMRx_CNT_END) (x=0/1/2/3)

Bit	Name	Access	Description	Reset value
[31:0]	R32_TMRx_CNT_END	RW	In timer mode, the number of clocks in one timing cycle; In PWM mode, the total number of clocks in one single cycle of PWM; In capture mode, the number of capture timeout clocks. Only the lower 26 bits are valid, with a maximum value of 67108863. In count mode, final count value -2 (overflow). <i>Note: Write operation on this register will automatically clear the value in register R32_TMRx_COUNT.</i>	0XXXXXXXXh

FIFO Register (R32_TMRx_FIFO) (x=0/1/2/3)

Bit	Name	Access	Description	Reset value
[31:0]	R32_TMRx_FIFO	RO/WO	The FIFO data register. Only the lower 26 bits are valid.	0XXXXXXXXh

DMA Control Register (R8_TMRx_CTRL_DMA) (x=1/2) (only supported by TMR1/2)

Bit	Name	Access	Description	Reset value
[7:3]	Reserved	RO	Reserved	00000b
2	RB_TMR_DMA_LOOP	RW	DMA address cycle feature enable bit: 1: Enable address loop; 0: Disable address loop. If the DMA address loop is enabled, when the DMA address is added to the end address of the setting, it will automatically circulate and point to the set first address.	0
1	Reserved	RO	Reserved	0
0	RB_TMR_DMA_ENABLE	RW	DMA feature enable bit: 1: Enable DMA; 0: Disable DMA.	0

DMA Current Buffer Zone Address (R16_TMRx_DMA_NOW) (x=1/2)

Bit	Name	Access	Description	Reset value
[15:0]	R16_TMRx_DMA_NOW	RO	The current address of the DMA data buffer zone. It can be used to calculate the number of conversions. The calculation method: COUNT = (TMR_DMA_NOW-TMR_DMA_BEG) / 4.	XXXXh

DMA Start Buffer Zone Address (R16_TMRx_DMA_BEG) (x=1/2)

Bit	Name	Access	Description	Reset value
[15:0]	R16_TMRx_DMA_BEG	RW	The start address of the DMA data buffer zone. Only the lower 15 bits are valid. The address must be 4 bytes aligned.	XXXXh

DMA End Buffer Zone Address (R16_TMRx_DMA_END) (x=1/2)

Bit	Name	Access	Description	Reset value
[15:0]	R16_TMRx_DMA_END	RW	The end address of the DMA data buffer zone (not included). Only the lower 15 bits are valid. The address must be 4 bytes aligned.	XXXXh

8.3 Function description and configuration

8.3.1 Timing and counting function

Each timer on chip supports a maximum timing of 2^{26} clock cycles and performs an incremental count mode. If the system clock cycle is 32MHz, the maximum timing is: $31.25\text{nS} * 2^{26} \approx 2\text{S}$. Each timer has an independent interrupt.

The timing function is operated as follows:

- (1) Set RB_TMR_ALL_CLEAR to clear R32_TMRx_COUNT and interrupt flags, etc.
- (2) Set the Register R32_TMRx_CNT_END to the value that needs to be timed; The specific calculation method is: $\text{Time} = T_{\text{sys}} * R32_TMRx_CNT_END$;
- (3) Reset RB_TMR_ALL_CLEAR, and reset the timing mode corresponding to RB_TMR_MODE_IN;
- (4) Optional step. Set R8_TMRx_INTER_EN Register, and set RB_TMR_IE_CYC_END to open the timing cycle interrupt;
- (5) Set RB_TMR_COUNT_EN of R8_TMRx_CTRL_MOD Register to start the counting of the timer.
- (6) When the counting of R32_TMRx_COUNT is equal to R32_TMRx_CNT_END, the timing is completed. At this time, set RB_TMR_IF_CYC_END of R8_TMRx_INT_FLAG to 1, and write 1 to reset.

The counting function is operated as follows:

- (1) Set the direction of the I/O pin corresponding to the count to input.
- (2) Set the count overflow end value in R32_TMRx_CNT_END.
- (3) Configure R8_TMRx_CTRL_MOD, set RB_TMR_MODE_IN and RB_TMR_CAP_COUNT corresponding to the count mode, clear the RB_TMR_ALL_CLEAR bit, select the sampling edge mode by RB_TMR_CAP_EDGE, set RB_TMR_COUNT_EN to 1 to enable the counting function.
- (4) Optional step, set the corresponding interrupt enable register bit if interrupts need to be enabled.
- (5) R32_TMRx_COUNT stores the current count value, every time the count reaches the end value, RB_TMR_IE_CYC_END will be set to 1 and R32_TMRx_COUNT will be cleared to 0. If the interrupt is enabled, a hardware interrupt will be triggered.

8.3.2 PWM

Each timer on chip has the feature of PWM. The PWM feature of TMR1 and TMR2 supports DMA data loading. The PWM can set the default output polarity to be high level or low level. The number of the same data duplication output can be selected as 1, 4, 8 or 16. This duplication feature combined with DMA can be used to simulate the effect of DAC. The shortest time unit of the PWM output active level is 1 system clock. The duty ratio of the PWM can be dynamically modified to simulate special waveforms.

PWM is operated at the following steps:

- (1) Set RB_TMR_ALL_CLEAR, empty and reset R32_TMRx_FIFO, interrupt flags, etc.
- (2) Set the PWM total cycle register R32_TMRx_CNT_END. This value should be no less than the value in the R32_TMRx_FIFO register;
- (3) Configure R8_TMRx_CTRL_MOD, reset RB_TMR_ALL_CLEAR, reset the PWM mode corresponding to RB_TMR_MODE_IN, select the output polarity through RB_TMR_OUT_POLAR, and select the number of the same data duplications through RB_TMR_PWM_REPEAT as needed;
- (4) Set data register R32_TMRx_FIFO. The minimum value is 0; the corresponding duty ratio is 0%; the maximum value is the same as R32_TMR_CNT_END; the corresponding duty ratio is 100%. The duty ratio is calculated as: R32_TMRx_FIFO/R32_TMRx_CNT_END. TMR1 and TMR2 can load continuous dynamic data through DMA and combine the number of the same data duplication output to simulate special waveforms;
- (5) Configure R8_TMRx_CTRL_MOD, set RB_TMR_COUNT_EN to start counting and RB_TMR_OUT_EN to allow the output of PWM;
- (6) Set the I/O pin corresponding to PWM as the output;
- (7) Optional step. If an interrupt needs to be enabled, set the corresponding interrupt enable register bit;
- (8) After one cycle of PWM is completed, if an interrupt is enabled, the hardware interrupt will be triggered after RB_TMR_IF_DATA_ACT or RB_TMR_IF_CYC_END is set.
- (9) Update the data in R32_TMRx_FIFO to dynamically change the duty ratio of PWM. It is recommended to load by DMA.

For example, RB_TMR_OUT_POLAR bit is set to 0; R32_TMRx_FIFO is set to 6; R32_TMRx_CNT_END is set to 18. The basic timing diagram for generating PWM is shown below. The duty ratio is: R32_TMRx_FIFO / R32_TMRx_CNT_END = 1/3.

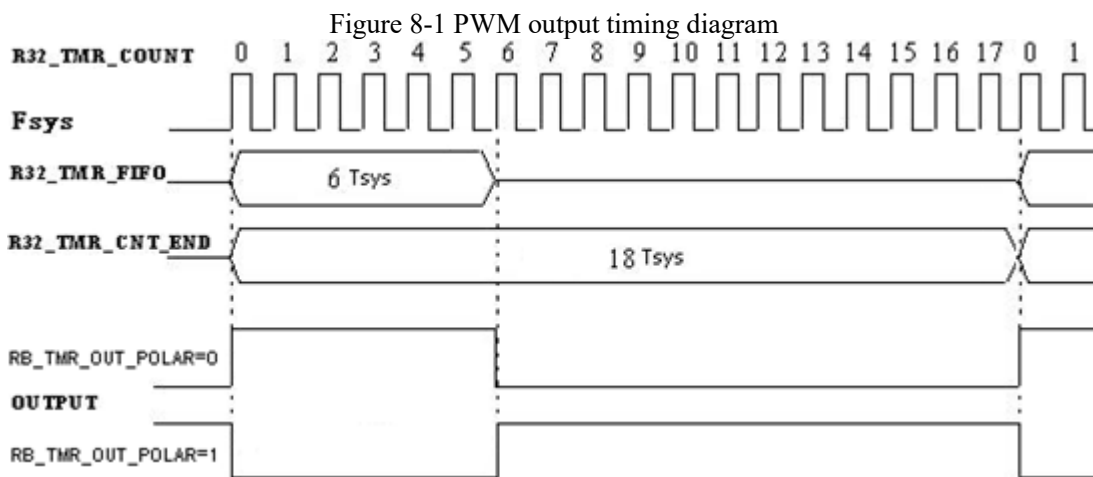

If RB_TMR_PWM_REPEAT is set to 00, it means that the above process is repeated once; 01 means repeating 4 times; 10 means repeating 8 times; 11 means repeating 16 times. After repetitions, continue to load the next data in the FIFO.

8.3.3 Capture

Each timer of the chip has the feature of capture. Specifically, the capture feature of TMR1 and TMR2 supports DMA data storage. Users can select from three capture modes: start from any edge trigger and end at any edge trigger, start from rising edge trigger and end at rising edge trigger, and start from falling edge trigger and end at falling edge trigger. The following table illustrates the modes of capture trigger:

Table 8-5 Capture trigger modes

Capture mode select bit RB_TMR_CATCH_EDGE	Trigger mode	Icon
00	No capture	None
01	Edge trigger Edge to edge	
10	Falling edge to falling edge	

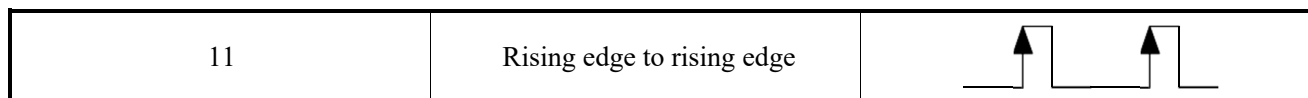

Two trigger states in the edge trigger mode can capture the width at high level or the width at low level. If the highest bit (bit 25) of the valid data of the data register R32_TMRx_FIFO is 1, it indicates that the high level is captured, and 0 indicates that the low level is captured. If bit 25 of consecutive sets of data is 1 (or 0), it indicates that the width of the high (or low) level exceeds the timeout value and needs to be combined and accumulated.

In the trigger mode of falling edge to falling edge and rising edge to rising edge, an input change cycle can be captured. If the highest bit (bit 25) of the valid data of the data register R32_TMRx_FIFO is 0, it indicates that the normal sampling lasts one cycle, and 1 means that the input change cycle exceeds the timeout value of R32_TMRx_CNT_END. The latter group of data should be added and accumulated as a single input change cycle. The details are as follows:

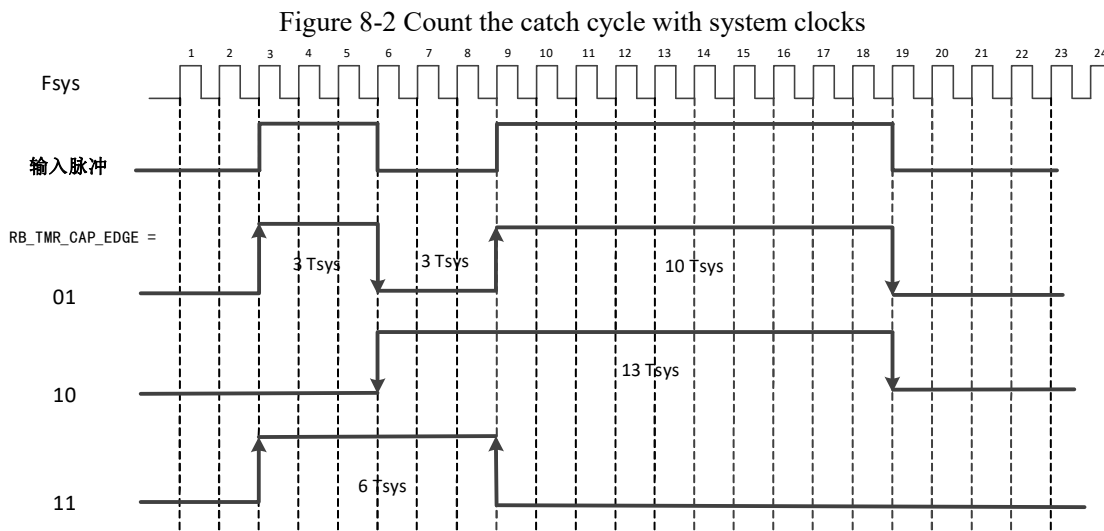

As shown in the figure above, samples are taken once at each clock cycle:

When RB_TMR_CATCH_EDGE=01b, sampling is set to the mode of edge trigger. The width of sampled time is 3, 3, 10;

When RB_TMR_CATCH_EDGE=10b, sampling is set to the mode of falling edge to falling edge. The width of sampled time is 13;

When RB_TMR_CATCH_EDGE= 11b, sampling is set to the mode of rising edge to rising edge. The width of sampled time is 6.

Capture mode is operated in the following steps:

- (1) Set RB_TMR_ALL_CLEAR, empty and reset R32_TMRx_FIFO, interrupt flags, etc.
- (2) Set the I/O pin direction corresponding to capture as the input;
- (3) Set a reasonable capture timeout time in R32_TMRx_CNT_END, which can be used to generate timeout interrupt when the input signal has not changed for a long time, or to generate timeout data after the input signal has no change in timeout (Bit 25 of data is 1. The lower 25 bits can be accumulated backwards);
- (4) Configure R8_TMRx_CTRL_MOD, set the capture mode corresponding to RB_TMR_MODE_IN, select the captured edge mode by RB_TMR_CAP_EDGE, set RB_TMR_COUNT_EN of R8_TMRx_CTRL_MOD to 1 to enable counting;
- (5) Optional step. If an interrupt needs to be enabled, set the corresponding interrupt enable register bit;
- (6) If the captured data needs to be saved by means of DMA, set Register R16_TMRx_DMA_BEG as the first address of the buffer zone where the captured data is stored. Set Register R16_TMRx_DMA_END as the end address of the buffer zone where the captured data is stored (not included), and set RB_TMR_DMA_ENABLE of R8_TMRx_CTRL_DMA as 1 to enable the DMA feature;
- (7) Reset the RB_TMR_ALL_CLEAR of R8_TMRx_CTRL_MOD to start the capture feature.
- (8) Each time data is captured, RB_TMR_IF_DATA_ACT will be set to 1. If interrupt is enabled, the hardware interrupt will be triggered. The captured data is stored in R32_TMRx_FIFO by default. If DMA is enabled, the captured data will be automatically stored in the data buffer zone set in the DMA.

Chapter 9 Universal Asynchronous Receiver Transmitter (UART)

9.1 UART introduction

A chip is provided with 4 sets of full-duplex asynchronous serial ports (UART0/1/2/3) and supports full-duplex and half-duplex serial communication. Specifically, UART0 provides transmit status pins for switching RS485 and supports MODEM signals including CTS, DSR, RI, DCD, DTR and RTS.

9.1.1 Main features

- Compatible with 16C550 asynchronous serial port and enhanced.
- Support 5, 6, 7 or 8 data bits and 1 or 2 stop bits.
- Support odd, even, no parity, blank 0, flag 1 and other verification methods.
- Programmable communication baud rate up to 5Mbps.
- Built-in 8-byte FIFO buffer supports 4 FIFO trigger stages.
- UART0 supports MODEM signals including CTS, DSR, RI, DCD, DTR, RTS.
- UART0 supports hardware flow control signals CTS, RTS automatic handshake and automatic transmission rate control, and is compatible with TL16C550C.
- Support the detection of serial frame errors and break circuit interval.
- Support full-duplex and half-duplex serial communication. UART0 provides transmit status pins for switching RS485.

9.2 Register description

Table 9-1 List of UART0-related registers

Name	Access address	Description	Reset value
R8_UART0_MCR	0x40003000	MODEM control register	0x00
R8_UART0_IER	0x40003001	Interrupt enable register	0x00
R8_UART0_FCR	0x40003002	FIFO control register	0x00
R8_UART0_LCR	0x40003003	Line control register	0x00
R8_UART0_IIR	0x40003004	Interrupt identification register	0x01
R8_UART0_LSR	0x40003005	Line status register	0x60
R8_UART0_MSR	0x40003006	MODEM status register	0xX0
R8_UART0_RBR	0x40003008	Receive buffer register	0xXX
R8_UART0_THR	0x40003008	Transmit hold register	0xXX
R8_UART0_RFC	0x4000300A	Receive FIFO count register	0x00
R8_UART0_TFC	0x4000300B	Transmit FIFO count register	0x00
R16_UART0_DL	0x4000300C	Baud rate divisor latch	0xXX
R8_UART0_DIV	0x4000300E	Prescaler divisor register	0xXX
R8_UART0_ADR	0x4000300F	Slave address register	0xFF

Table 9-2 List of UART1-related registers

Name	Access address	Description	Reset value
R8_UART1_MCR	0x40003400	MODEM control register	0x00
R8_UART1_IER	0x40003401	Interrupt enable register	0x00
R8_UART1_FCR	0x40003402	FIFO control register	0x00
R8_UART1_LCR	0x40003403	Line control register	0x00
R8_UART1_IIR	0x40003404	Interrupt identification register	0x01

R8_UART1_LSR	0x40003405	Line status register	0x60
R8_UART1_RBR	0x40003408	Receive buffer register	0xXX
R8_UART1_THR	0x40003408	Transmit hold register	0xXX
R8_UART1_RFC	0x4000340A	Receive FIFO count register	0x00
R8_UART1_TFC	0x4000340B	Transmit FIFO count register	0x00
R16_UART1_DL	0x4000340C	Baud rate divisor latch	0xXX
R8_UART1_DIV	0x4000340E	Prescaler divisor register	0xXX

Table 9-3 List of UART2-related registers

Name	Access address	Description	Reset value
R8_UART2_MCR	0x40003800	MODEM control register	0x00
R8_UART2_IER	0x40003801	Interrupt enable register	0x00
R8_UART2_FCR	0x40003802	FIFO control register	0x00
R8_UART2_LCR	0x40003803	Line control register	0x00
R8_UART2_IIR	0x40003804	Interrupt identification register	0x01
R8_UART2_LSR	0x40003805	Line status register	0x60
R8_UART2_RBR	0x40003808	Receive buffer register	0xXX
R8_UART2_THR	0x40003808	Transmit hold register	0xXX
R8_UART2_RFC	0x4000380A	Receive FIFO count register	0x00
R8_UART2_TFC	0x4000380B	Transmit FIFO count register	0x00
R16_UART2_DL	0x4000380C	Baud rate divisor latch	0xXX
R8_UART2_DIV	0x4000380E	Prescaler divisor register	0xXX

Table 9-4 List of UART3-related registers

Name	Access address	Description	Reset value
R8_UART3_MCR	0x40003C00	MODEM control register	0x00
R8_UART3_IER	0x40003C01	Interrupt enable register	0x00
R8_UART3_FCR	0x40003C02	FIFO control register	0x00
R8_UART3_LCR	0x40003C03	Line control register	0x00
R8_UART3_IIR	0x40003C04	Interrupt identification register	0x01
R8_UART3_LSR	0x40003C05	Line status register	0x60
R8_UART3_RBR	0x40003C08	Receive buffer register	0xXX
R8_UART3_THR	0x40003C08	Transmit hold register	0xXX
R8_UART3_RFC	0x40003C0A	Receive FIFO count register	0x00
R8_UART3_TFC	0x40003C0B	Transmit FIFO count register	0x00
R16_UART3_DL	0x40003C0C	Baud rate divisor latch	0xXX
R8_UART3_DIV	0x40003C0E	Prescaler divisor register	0xXX

MODEM Control Register (R8_UARTx_MCR) (x=0/1/2/3)

Bit	Name	Access	Description	Reset value
-----	------	--------	-------------	-------------

7	RB_MCR_HALF	RW	Half-duplex transceiver mode control (only supported by UART0): 1: Enter the half-duplex transceiver mode, transmit with priority, and receive when not transmitting; 0: Disable the half-duplex mode.	0
6	RB_MCR_TNOW	RW	Enable the status where DTR pin output is being transmitted (only supported by UART0): 1: Output the indication status of being transmitted to DTR pins so as to control the switching of RS485 transceiver; 0: DTR pins are in normal function.	0
5	RB_MCR_AU_FLOW_EN	RW	CTS and RTS hardware automatic flow control enable (only supported by UART0): 1: Enable CTS and RTS hardware automatic flow control; 0: Disable CTS and RTS hardware automatic flow control. In the flow control mode, if this bit is 1, UART will continue to transmit the next data only when it detects that the CTS pin is valid (active at low level), otherwise it will suspend UART transmission. When this bit is 1, the change in CTS input status will not generate the MODEM status interrupt. If this bit is 1 and RTS is 1, when the received FIFO is empty, UART will automatically make the RTS pins valid (active at low level). Until the number of received bytes reaches the trigger point of the FIFO, UART will automatically invalidate the RTS pins and validate the RTS pins again when receiving empty FIFO. Hardware automatic flow control can be used to connect the CTS pins to the other's RTS pins and transmit the RTS pins to the other's CTS pins.	0
4	RB_MCR_LOOP	W	Enable the test mode of internal loop (only supported by UART0): 1: Enable the test mode of internal loop; 0: Disable the test mode of internal loop. In the test mode of the internal loop, all external output pins of UART are inactive. TXD internally returns to RXD; RTS internally returns to CTS; DTR internally returns to DSR; OUT1 internally returns to RI; OUT2 internally returns to DCD.	0
3	RB_MCR_OUT2 RB_MCR_INT_OE	RW	UART interrupt request output control bit: 1: Allow sending request; 0: Disabled.	0
2	RB_MCR_OUT1	RW	User-defined MODEM control bit (only supported by UART0). No actual output pin connected: 1: Set high; 0: Set low.	0
1	RB_MCR_RTS	RW	RTS signal output level control (only supported by UART0): 1: RTS signal output is active (at low level); 0: RTS signal output at high level (by default).	0
0	RB_MCR_DTR	RW	DTR signal output level control (only supported by UART0): 1: DTR signal output is active (at low level); 0: DTR signal output at high level (by default).	0

Interrupt Enable Register (R8_UARTx_IER) (x=0/1/2/3)

Bit	Name	Access	Description	Reset value
7	RB_IER_RESET	WZ	UART Software Reset Control Bit. Automatically reset: 1: Software resets the serial port; 0: Normal operation.	0

6	RB_IER_TXD_EN	RW	UART TXD Pin Output Enable Bit: 1: Enable pin output; 0: Disable pin output.	0
5	RB_IER_RTS_EN	RW	RTS Pin Output Enable Bit (only supported by UART0): 1: Enable pin output; 0: Disable pin output.	0
4	RB_IER_DTR_EN	RW	DTR Pin Output Enable Bit (only supported by UART0): 1: Enable pin output; 0: Disable pin output.	0
3	RB_IER_MODEM_CHG	RW	Modem Input Status Change Interrupt Enable Bit (only supported by UART0): 1: Enable interrupt; 0: Disable interrupt.	0
2	RB_IER_LINE_STAT	RW	Transmit Line Status Interrupt Enable Bit: 1: Enable interrupt; 0: Disable interrupt.	0
1	RB_IER_THR_EMPTY	RW	Transmit Hold Register Empty Interrupt Enable Bit: 1: Enable interrupt; 0: Disable interrupt.	0
0	RB_IER_RECV_RDY	RW	Receive Data Interrupt Enable Bit: 1: Enable interrupt; 0: Disable interrupt.	0

FIFO Control Register (R8 UARTx_FCR) (x=0/1/2/3)

Bit	Name	Access	Description	Reset value
[7:6]	RB_FCR_FIFO_TRIG	RW	Select the trigger points of receiving FIFO interrupt and hardware flow control: 00: 1 byte; 01: 2 bytes; 10: 4 bytes; 11: 7 bytes. It is used to set the trigger points for receiving FIFO interrupt and hardware flow control. For example: 10 corresponds to 4 bytes. In other words, receiving 4 bytes can generate interrupts of receiving data and automatically invalidate RTS pins when the hardware flow control is enabled.	00b
[5:3]	Reserved	RO	Reserved	000b
2	RB_FCR_TX_FIFO_CLR	WZ	Transmit FIFO data clear enable bit. Automatically reset to zero: 1: Clear the data of the transmitted FIFO (excluding TSR); 0: Not clear the data of the transmitted FIFO.	0
1	RB_FCR_RX_FIFO_CLR	WZ	Receive FIFO data rest enable bit. Automatically reset to zero: 1: Clear the received FIFO data (RSR not included); 0: Not clear the received FIFO data.	0
0	RB_FCR_FIFO_EN	RW	FIFO enable bit: 1: Enable 8-byte FIFO; 0: Disable FIFO. After FIFO is disabled, it is 16C450 compatible mode, that is, only one byte in FIFO (RECV_TG1=0, RECV_TG0=0, FIFO_EN=1). Enable is recommended.	0

Line Control Register (R8 UARTx_LCR) (x=0/1/2/3)

Bit	Name	Access	Description	Reset value
7	RB_LCR_DLAB RB_LCR_GP_BIT	RW	UART general-purpose bit, user-defined.	0
6	RB_LCR_BREAK_EN	RW	Force the BREAK line interval enable bit: 1: Forced generation; 0: Not generated.	0

[5:4]	RB_LCR_PAR_MOD	RW	Select odd-even check bit format: 00: Odd parity check; 01: Even parity check; 10: Flag bit (MARK, set to 1); 11: Blank bit (SPACE, clear to 0). Only valid when the RB_LCR_PAR_EN bit is 1.	00b
3	RB_LCR_PAR_EN	RW	Odd-even check bit enable bit: 1: Allow odd-even check bits to be generated and received at the time of transmission; 0: No odd-even check bit.	0
2	RB_LCR_STOP_BIT	RW	Stop bit format setting bit: 0: One stop bit; 1: Two stop bits.	0
[1:0]	RB_LCR_WORD_SZ	RW	Select the length of serial data: 00: 5 data bits; 01: 6 data bits; 10: 7 data bits; 11: 8 data bits.	00b

Interrupt Identification Register (R8_UARTx_IIR) (x=0/1/2/3)

Bit	Name	Access	Description	Reset value
[7:6]	RB_IIR_FIFO_ID	RO	UART FIFO enable status bit: 11: FIFO has been enabled; 00: FIFO is not enabled.	00b
[5:4]	Reserved	RO	Reserved	00b
[3:0]	RB_IIR_INT_MASK	RO	Interrupt flag: If the RB_IIR_NO_INT bit is 0, it indicates that an interrupt is generated, and the interrupt source needs to be judged after reading. See Table 9-5 for details.	0000b
0	RB_IIR_NO_INT	RO	UART no interrupt flag: 1: No interrupt; 0: Interrupt.	1

The following table demonstrates the meanings of the RB_IIR_NO_INT bit of the Interrupt Identification Register R8_UARTx_IIR and each bit of RB_IIR_INT_MASK:

Table 9-5 Meaning of IR_IIR_INT_MASK in IIR Register

IIR register bit				Priority	Types of interrupt	Interrupt source	Method of clearing interrupts
IID3	IID2	IID1	NOINT				
0	0	0	1	None	No interrupt	No interruption	
1	1	1	0	0	Bus address matching	One data received is UART bus address, and the address matches the preset slave value or the broadcast address. (only supported by UART0)	Read IIR or disable multi-machine mode
0	1	1	0	1	Receiving line status	OVER_ERR, PAR_ERR, FRAM_ERR, BREAK_ERR	Read LSR
0	1	0	0	2	Receive data available	The number of bytes received reaches the trigger point of FIFO.	Read RBR
1	1	0	0	2	Receive data timeout	The next data is not received for more than 4 data hours.	Read RBR
0	0	1	0	3	THR register empty	Transmit hold register is empty, or the RB_IER_THR_EMPTY bit is changed from 0 to 1 and triggered.	Read IIR or write THR
0	0	0	0	4	MODEM input change	Δ CTS, Δ DSR, Δ RI, Δ DCD are set as 1 to trigger.	Read MSR

Line Status Register (R8_UARTx_LSR) (x=0/1/2/3)

Bit	Name	Access	Description	Reset value
7	RB_LSR_ERR_RX_FIFO	O	Receive FIFO Error Flag Bit: 1: There is at least one PAR_ERR, FRAM_ERR or BREAK_ERR error in the received FIFO; 0: There is no error in the received FIFO.	0
6	RB_LSR_TX_ALL_EMP	RO	Transmit Hold Register (THR) and Transmit Shift Register (TSR) Empty Flag Bit: 1: Both are empty; 0: Both are not empty.	1
5	RB_LSR_TX_FIFO_EMP	RO	Transmit FIFO Empty Flag Bit: 1: Transmit FIFO is empty; 0: Transmit FIFO is not empty.	1
4	RB_LSR_BREAK_ERR	RZ	BREAK Line Interval Detection Flag Bit: 1: BREAK is detected; 0: BREAK is not detected.	0
3	RB_LSR_FRAME_ERR	RZ	Data Frame Error Flag Bit: 1: There is a frame error in the data read from the FIFO being received, and a valid stop bit is missing; 0: There is no error in the currently read data frame.	0
2	RB_LSR_PAR_ERR	RZ	Receive Data Odd-even Check Error Flag Bit: 1: There is an odd-even check error in the data read from the FIFO being received; 0: The currently read data odd-even check is correct.	0
1	RB_LSR_OVER_ERR	RZ	Received FIFO Buffer Zone Overflow Flag Bit: 1: Has overflown; 0: No overflow.	0
0	RB_LSR_DATA_RDY	RO	There are Received Data in the Received FIFO Flag Bit: 1: There is data in the FIFO; 0: No data. This bit is automatically reset to 0 after all data in the FIFO has been read.	0

MODEM status register (R8_UART0_MSR) (only supported by UART0)

Bit	Name	Access	Description	Reset value
7	RB_MSR_DCD	RO	DCD pin status bit: 1: DCD pin is active (at low level); 0: DCD pin is inactive (at high level).	X
6	RB_MSR_RI	RO	RI pin status bit: 1: RI pin is active (at low level); 0: RI pin is inactive (at high level).	X
5	RB_MSR_DSR	RO	DSR pin status bit: 1: DSR pin is active (at low level); 0: DSR pin is inactive (at high level).	X
4	RB_MSR_CTS	RO	CTS pin status bit: 1: CTS pin is active (at low level); 0: CTS pin is invalid (at high level).	X
3	RB_MSR_DCD_CHG	RZ	DCD pin input status change flag bit: 1: Has changed; 0: No change.	0
2	RB_MSR_RI_CHG	RZ	RI pin input status change flag bit: 1: Has changed; 0: No change.	0

1	RB_MSR_DSR_CHG	RZ	DSR pin input status change flag bit: 1: Has changed; 0: No change.	0
0	RB_MSR_CTS_CHG	RZ	CTS pin input status change flag bit: 1: Has changed; 0: No change.	0

Receive Buffer Register (R8_UARTx_RBR) (x=0/1/2/3)

Bit	Name	Access	Description	Reset value
[7:0]	R8_UARTx_RBR	RO	Data reception buffer register. If the DATA_RDY bit of LSR is 1, the received data can be read from this register; If FIFO_EN is 1, the data received from the UART shift register (RSR) is first stored in the received FIFO and then read out via this register.	XXh

Transmit Hold Register (R8_UARTx_THR) (x=0/1/2/3)

Bit	Name	Access	Description	Reset value
[7:0]	R8_UARTx_THR	RO	Transmit hold register. It includes a transmit FIFO used for writing data to be transmitted. If FIFO_EN is 1, the written data is first stored in the transmitted FIFO and then output one by one via the transmit shift register (TSR).	XXh

Receive FIFO Count Register (R8_UARTx_RFC) (x=0/1/2/3)

Bit	Name	Access	Description	Reset value
[7:0]	R8_UARTx_RFC	RO	The count of the data in the current received FIFO.	00h

Transmit FIFO Count Register (R8_UARTx_TFC) (x=0/1/2/3)

Bit	Name	Access	Description	Reset value
[7:0]	R8_UARTx_TFC	RO	The count of the data in the current transmitted FIFO.	00h

Baud Rate Divisor Latch (R16_UARTx_DL) (x=0/1/2/3)

Bit	Name	Access	Description	Reset value
[15:0]	R16_UARTx_DL	RW	The 16-bit divisor is used to calculate the baud rate. Formula: Divisor = UART Internal Reference Clock / 16 / required communication baud rate. Example: If the UART internal reference clock Fuart is 1.8432MHz and the required baud rate is 9600bps, Divisor = 1,843,200/16/9,600=12.	XXXXh

Prescaler Divisor Register (R8_UARTx_DIV) (x=0/1/2/3)

Bit	Name	Access	Description	Reset value
[7:0]	R8_UARTx_DIV	RW	It is used to calculate the internal reference clock of UART. The low 7 bits are valid. Formula: Divisor = Fsys*2 / Internal reference clock of UART. The maximum value is 127.	XXh

Slave Address Register (R8_UART0_ADR) (only supported by UART0)

Bit	Name	Access	Description	Reset value
[7:0]	R8_UART0_ADR	RW	The slave address when UART0 is in multi-machine communication. FFh: Not used; Other: Slave address.	0FFh

R8_UART0_ADR presets the local machine as the address of the slave, which is used to automatically compare with the received addresses during multi-machine communication and generate an interrupt when the addresses match or when the broadcast address 0FFH is received. The subsequent packets are allowed to be received. No data shall be received before the addresses match. Any data shall be stopped receiving after the data starts to be received or the R8_UART0_ADR Register is rewritten. Data is allowed to be received until the next address matches again or when the broadcast address is received.

When R8_UART0_ADR is 0FFH or RB_LCR_PAR_EN=0, the function of bus address auto compare is disabled. When R8_UART0_ADR is not 0FFH and RB_LCR_PAR_EN=1, the function of bus address auto compare is enabled. At the same time, the following parameters should be configured: RB_LCR_WORD_SZ is 11b, and the method of 8 data bits is selected. For the case where the address byte is MARK (i.e., Bit 9 of the data byte is 0), RB_LCR_PAR_MOD should be set to 10b. For the case where the address byte is SPACE (i.e., Bit 9 of the data byte is 1), RB_LCR_PAR_MOD should be set to 11b.

9.3 Function description and configuration

UART0/1/2/3 output pins are all 3.3V LVCMOS levels. The pins in UART mode include: data transmission pins and MODEM contact signal pins (only supported by UART0). Data transmission pins include TXD pins and RXD pins, and default at high level. MODEM contact signal pins include CTS pins, DSR pins, RI pins, DCD pins, DTR pins and RTS pins, and default at high level. All of these MODEM contact signals can be used as general purpose I/O pins, which are controlled by the applications and defined for their purpose.

Each of the four UARTs has an independent transceiver buffer zone and an 8-byte FIFO that supports simplex, half-duplex or full-duplex asynchronous serial communication. Serial data includes 1 low-level start bit, 5, 6, 7 or 8 data bits, 0 or 1 additional check bit or flag bit, 1 or 2 high level stop bit and supports odd check/even check/flag check/blank check. The baud rate error of UART transmission signals is less than 0.5%, and the allowable baud rate error of UART receiving signals is not more than 2%.

9.3.1 Baud rate calculation

- 1) Calculate UART internal reference clock Fuart, and set the R8_UARTx_DIV Register. The maximum value is 127, and normally 1 is written.
 - 2) Calculate the baud rate and set the R16_UARTx_DL Register.
- Baud Rate Formula = $F_{sys} * 2 / R8_UARTx_DIV / 16 / R16_UARTx_DL$.

9.3.2 UART transmission

"THR Register Empty" UART_II_THR_EMPTY interrupt sent by UART means that the current transmitted FIFO is empty. The interrupt is cleared when the IIR register is read or when the next data is written into the THR. If only one byte is written into THR, since the byte is quickly transferred to the transmit shift register (TSR) and starts to be transmitted, the request to send the THR register empty interrupt will be generated again soon. At this time, the next data to be sent can be written in. When the data in the TSR register is completely removed, the UART transmission is completed in a real sense. At this time, RB_LSR_TX_ALL_EMP bit of the LSR Register becomes 1 and active.

In the mode of interrupt trigger, after the interrupt of UART transmit hold register (THR) empty is received, if FIFO is enabled, up to 8 bytes can be written into the THR register and FIFO at a time, and then the controller will automatically send in order; if FIFO is disabled, only one byte can be written at one time; if no data needs to be sent, exit directly (the interrupt is automatically cleared when IIR is read before).

In the mode of query, whether the transmitted FIFO is empty can be judged according to the RB_LSR_TX_FIFO_EMP bit of the LSR Register. When this bit is 1, the data can be written to THR Register and FIFO. If FIFO is enabled, a maximum of 8 bytes can be written at one time.

R8_UARTx_TFC Register can also be read to know the number of remaining data to be sent in the current FIFO. If it is not equal to 8, the data to be sent can continue to be written in FIFO. This method can save filling time.

9.3.3 UART reception

UART Receive Data Available Interrupt `UART_II_RECV_RDY` means that the number of existing data bytes in the received FIFO has reached or exceeded the FIFO trigger point selected by the setting of `RB_FCR_FIFO_TRIG` in the FCR Register. This interrupt is cleared when reading data from RBR makes the number of FIFO words below the trigger point of FIFO.

UART Receive Data Timeout Interrupt `UART_II_RECV_TOUT` means that there is at least one byte of data in the received FIFO, and the waiting time is equivalent to the time of receiving 4 data starting from the last time when UART receives data and from the last time when data is taken away by the system. The interrupt can be cleared after a new data is received again or after the RBR Register is read once. When the received FIFO is completely empty, the `RB_LSR_DATA_RDY` bit in LSR Register is 0. When there is data in the received FIFO, the `RB_LSR_DATA_RDY` bit is 1 and active.

In the mode of interrupt trigger, after UART Receive Data Timeout Interrupt is received, read `R8_UARTx_RFC` Register to query the remaining data count in the current FIFO and read all the data directly, or continuously query `RB_LSR_DATA_RDY` of LSR Register. If this bit is valid, read the data until this bit is invalid. After UART Receive Data Available Interrupt is received, read the `RB_FCR_FIFO_TRIG` at one time from the RBR Register to get the number of bytes, or read all data in the current FIFO according to the `RB_LSR_DATA_RDY` bit and `R8_UARTx_RFC` Register.

In the mode of query, the `RB_LSR_DATA_RDY` bit of LSR Register can be used to determine whether the received FIFO is empty, or the `R8_UARTx_RFC` Register can be read to obtain the current data count of FIFO and all the data received by UART.

9.3.4 Hardware flow control

Hardware flow control includes automatic CTS (`RB_MCR_AU_FLOW_EN` set to 1) and automatic RTS (`RB_MCR_AU_FLOW_EN` and `RB_MCR_RTS` are both set to 1).

If automatic CTS is enabled, CTS pins must be valid before UART sends data. UART transmitter detects CTS pins before sending the next data. When the status of CTS pins is valid, the transmitter sends the next data. In order to stop the transmitter from transmitting the following data, the CTS pins must be invalidated before the middle time of the last stop bit currently being transmitted. The feature of automatic CTS reduces the interrupt requested to the system. When hardware flow control is enabled, the change in the level of CTS pins does not trigger a MODEM interrupt because the controller automatically controls the transmitter based on the status of CTS pins. If automatic RTS is enabled, the output of RTS pins is valid only when there is enough space in the FIFO to receive data, and the output of RTS pins is invalid when the received FIFO is full. The output of RTS pins is valid if the data in the received FIFO is completely removed or emptied. When the trigger point of the received FIFO is reached (the number of bytes in the received FIFO is not less than the number of bytes set by the `RB_FCR_FIFO_TRIG` of the FCR Register), the output of RTS pins is invalid, and the other transmitter is allowed to send additional data after the RTS pins are invalid. Once the data of the received FIFO is emptied, the RTS pins are automatically reasserted, causing the other transmitter to resume transmission. If both automatic CTS and automatic RTS are enabled (both `RB_MCR_AU_FLOW_EN` and `RB_MCR_RTS` in the MCR register are 1), when its own RTS pins are connected to the other's CTS pins, unless there is enough space in the received FIFO of the other party, the other party will not send any data. Therefore, by virtue of this hardware flow control, FIFO overflow and timeout errors during UART reception can be avoided.

Chapter 10 Serial Peripheral Interface (SPI)

10.1 SPI introduction

SPI is a type of full-duplex serial interface with a master and a number of slaves connected to the bus. At the same time, only one pair of master and slave is in communication. Usually a SPI interface consists of 4 pins: SPI Chip Select Pin (SCS), SPI Clock Pin (SCK), SPI Serial Data Pin MISO (Master Input/Slave Output Pin), and SPI Serial Data Pin MOSI (Master Output/Slave Input Pin).

10.1.1 Main features

A chip is provided with two SPI interfaces with the following features:

- SPI0 supports both the master mode and the slave mode. SPI1 only supports the master mode.
- Compatible with the specifications of SPI.
- Support the modes of data transmission: mode 0 and mode 3.
- 8-bit data transmission mode. The sequence of data bits is optional: the low bits of a byte are in front or the high bits are in front.
- The clock frequency can be up to half of the system main frequency F_{sys} .
- 8-byte FIFO.
- SPI0 slave mode supports the first byte as the command mode or the data stream mode.
- SPI0 supports DMA. The efficiency of data transmission is higher.

10.2 Register description

Table 10-1 List of SPI0-related registers

Name	Access address	Description	Reset value
R8_SPI0_CTRL_MOD	0x40004000	SPI0 mode control register	0x02
R8_SPI0_CTRL_CFG	0x40004001	SPI0 configuration register	0x00
R8_SPI0_INTER_EN	0x40004002	SPI0 interrupt enable register	0x00
R8_SPI0_CLOCK_DIV R8_SPI0_SLAVE_PRE	0x40004003	SPI0 master mode clock divider register SPI0 slave mode preset data register	0x10
R8_SPI0_BUFFER	0x40004004	SPI0 data buffer zone	0xXX
R8_SPI0_RUN_FLAG	0x40004005	SPI0 working status register	0x00
R8_SPI0_INT_FLAG	0x40004006	SPI0 interrupt flag register	0x40
R8_SPI0_FIFO_COUNT	0x40004007	SPI0 transceiver FIFO count register	0x00
R16_SPI0_TOTAL_CNT	0x4000400C	SPI0 transceiver data total length register	0x0000
R8_SPI0_FIFO	0x40004010	SPI0 data FIFO register	0xXX
R8_SPI0_FIFO_COUNT1	0x40004013	SPI0 transceiver FIFO count register	0x00
R16_SPI0_DMA_NOW	0x40004014	SPI0 DMA buffer zone current address	0xXXXX
R16_SPI0_DMA_BEG	0x40004018	SPI0 DMA buffer zone start address	0xXXXX
R16_SPI0_DMA_END	0x4000401C	SPI0 DMA buffer zone end address	0xXXXX

Table 10-2 List of SPI1-related registers

Name	Access address	Description	Reset value
R8_SPI1_CTRL_MOD	0x40004400	SPI1 mode control register	0x02
R8_SPI1_CTRL_CFG	0x40004401	SPI1 configuration register	0x00
R8_SPI1_INTER_EN	0x40004402	SPI1 interrupt enable register	0x00
R8_SPI1_CLOCK_DIV	0x40004403	SPI1 master mode clock divider register	0x10
R8_SPI1_BUFFER	0x40004404	SPI1 data buffer zone	0xXX

R8_SPI1_RUN_FLAG	0x40004405	SPI1 working status register	0x00
R8_SPI1_INT_FLAG	0x40004406	SPI1 interrupt flag register	0x40
R8_SPI1_FIFO_COUNT	0x40004407	SPI1 transceiver FIFO count register	0x00
R16_SPI1_TOTAL_CNT	0x4000440C	SPI1 transceiver data total length register	0x00
R8_SPI1_FIFO	0x40004410	SPI1 data FIFO register	0xXX
R8_SPI1_FIFO_COUNT1	0x40004413	SPI1 transceiver FIFO count register	0x00

SPI Mode Control Register (R8_SPIx_CTRL_MOD) (x=0/1)

Bit	Name	Access	Description	Reset value
7	RB_SPI_MISO_OE	RW	MISO pin output enable bit (can be used for data line switching direction in the 2-wire mode): 1: MISO output enabled; 0: MISO output disabled.	0
6	RB_SPI_MOSI_OE	RW	MOSI pin output enable bit: 1: MOSI output enabled; 0: MOSI output disabled.	0
5	RB_SPI_SCK_OE	RW	SCK pin output enable bit: 1: SCK output enabled; 0: SCK output disabled.	0
4	RB_SPI_FIFO_DIR	RW	FIFO direction setting bit: 1: Input mode (indicating the reception of data); 0: Output mode (indicating the transmission of data).	0
3	RB_SPI_SLV_CMD_MOD	RW	Select the first byte mode (only supported by SPI0) in SPI0 slave mode: 1: First byte command mode; 0: Data stream mode. In the first byte command mode, after the first byte data is received when the SPI chip selection becomes valid, it will be regarded as the command code, and RB_SPI_IF_FST_BYTE will be set to 1.	0
3	RB_SPI_MST_SCK_MOD	RW	Select the clock idle mode in the master mode: 1: Mode 3 (SCK is at high level when idle); 0: Mode 0 (SCK is at low level when idle).	0
2	RB_SPI_2WIRE_MOD	RW	Select 2-wire or 3-wire SPI mode in the slave mode (SPI0 only, SPI1 does not require this control bit): 1: 2-wire mode / half-duplex (SCK/MISO); 0: 3-wire mode / full duplex (SCK/MOSI/MISO).	0
1	RB_SPI_ALL_CLEAR	RW	FIFO/Counter/Interrupt Flag of SPI is reset to zero: 1: Force emptying and clearing; 0: No clearing.	1
0	RB_SPI_MODE_SLAVE	RW	Select SPI0 master-slave mode (only supported by SPI0): 1: Slave mode; 0: Master mode.	0

SPI Configuration Register (R8_SPIx_CTRL_CFG) (x=0/1)

Bit	Name	Access	Description	Reset value
7	Reserved	RO	Reserved	0

6	RB_SPI_MST_DLY_EN	RW	Input delay enable in the master mode: 1: Enabled: used for high speed applications such as SPI clocks close to half of Fsys; 0: Disabled: regular applications.	0
5	RB_SPI_BIT_ORDER	RW	Select SPI data bit sequence: 1: Low bits in front; 0: High bits in front.	0
4	RB_SPI_AUTO_IF	RW	The function of automatically clearing the flag bit RB_SPI_IF_BYTE_END when accessing BUFFER/FIFO is enabled: 1: Enabled; 0: Disabled.	0
3	Reserved	RO	Reserved	0
2	RB_SPI_DMA_LOOP	RW	DMA address loop function enable bit (only supported by SPI0): 1: Enable address loop; 0: Disable address loop. If the DMA address loop is enabled, when the DMA address is added to the end address of the setting, the auto loop points to the set first address.	0
1	Reserved	RO	Reserved	0
0	RB_SPI_DMA_ENABLE	RW	DMA function enable bit (only supported by SPI0): 1: DMA enabled; 0: DMA disabled.	0

SPI Interrupt Enable Register (R8 SPIx INTER_EN) (x=0/1)

Bit	Name	Access	Description	Reset value
7	RB_SPI_IE_FST_BYTE	RW	In the first byte command mode of the slave mode, the first byte reception interrupt enable bit (only supported by SPI0); 1: Enable the first received byte interrupt; 0: Disable the first received byte interrupt.	0
[6:5]	Reserved	RO	Reserved	00b
4	RB_SPI_IE_FIFO_OV	RW	FIFO overflow (FIFO is full when receiving or FIFO is empty when transmitting) interrupt enable bit (only supported by SPI0): 1: Enable interrupt; 0: Disable interrupt.	0
3	RB_SPI_IE_DMA_END	W	DMA end interrupt enable bit (only supported by SPI0): 1: Enable interrupt; 0: Disable interrupt.	0
2	RB_SPI_IE_FIFO_HF	RW	More than half of FIFO used interrupt enable bit: 1: Enable interrupt; 0: Disable interrupt.	0
1	RB_SPI_IE_BYTE_END	RW	SPI single byte transmission completion interrupt enable bit: 1: Enable interrupt; 0: Disable interrupt.	0
0	RB_SPI_IE_CNT_END	RW	SPI all bytes transmission completion interrupt enable bit: 1: Enable interrupt; 0: Disable interrupt.	0

SPI Master Mode Clock Divider Register (R8 SPIx CLOCK_DIV) (x=0/1)

Bit	Name	Access	Description	Reset value
-----	------	--------	-------------	-------------

[7:0]	R8_SPI_CLOCK_DIV	RW	Division factor in the master mode. The minimum value is 2. F _{sck} = F _{sys} / division factor.	10h
-------	------------------	----	---	-----

SPI Slave Mode Preset Data Register (R8_SPI0_SLAVE_PRE) (only supported by SPI0)

Bit	Name	Access	Description	Reset value
[7:0]	R8_SPI_SLAVE_PRE	RW	Preset the first returned data in the slave mode. It is used to receive the returned data after the first byte data.	10h

SPI Data Buffer Zone (R8_SPIx_BUFFER) (x=0/1)

Bit	Name	Access	Description	Reset value
[7:0]	R8_SPIx_BUFFER	RW	SPI data transmit and reception buffer zone.	XXh

SPI Working Status Register (R8_SPIx_RUN_FLAG) (x=0/1)

Bit	Name	Access	Description	Reset value
7	RB_SPI_SLV_SELECT	RO	Chip selection status bit in the slave mode (only supported by SPI0): 1: Being selected; 0: No chip selection.	0
6	RB_SPI_SLV_CS_LOAD	RO	First loading status bit after chip is selected in the slave mode (only supported by SPI0): 1: Loading R8_SPI0_SLAVE_PRE; 0: Not loaded yet or have completed.	0
5	RB_SPI_FIFO_READY	RO	FIFO ready status bit: 1: FIFO is ready (R16_SPIx_TOTAL_CNT is not 0, and FIFO is not full when receiving or FIFO is not empty when transmitting); 0: FIFO is not ready.	0
4	RB_SPI_SLV_CMD_ACT	RO	Command reception completion status bit in the slave mode, that is, the first byte data has been exchanged (only supported by SPI0): 1: The first byte has just been exchanged; 0: The first byte has not been exchanged or it is not the first byte.	0
[3:0]	Reserved	RO	Reserved	0000b

SPI Interrupt Flag Register (R8_SPIx_INT_FLAG) (x=0/1)

Bit	Name	Access	Description	Reset value
7	RB_SPI_IF_FST_BYTE	RW1	In slave mode, the first byte received flag (only supported by SPI0): 1: The first byte has been received; 0: Not received.	0
6	RB_SPI_FREE	RO	Current SPI idle status bit: 1: Current SPI is idle; 0: The current SPI is not idle.	1
5	Reserved	RO	Reserved	0

4	RB_SPI_IF_FIFO_OV	RW1	FIFO overflow (FIFO is full when receiving or FIFO is empty when transmitting) flag bit. Write 1 to reset: 1: FIFO has overflowed; 0: FIFO has not overflowed.	0
3	RB_SPI_IF_DMA_END	RW1	DMA completion flag bit (only supported by SPI0). Write 1 to reset: 1: Completed; 0: Not completed.	X
2	RB_SPI_IF_FIFO_HF	RW1	More than half of FIFO used (FIFO>=4 when receiving or FIFO<4 when transmitting) flag bit. Write 1 to reset: 1: More than half of FIFO has been used; 0: More than half of FIFO has not been used;	0
1	RB_SPI_IF_BYTE_END	RW1	SPI single byte transfer completion flag bit. Write 1 to reset: 1: Single byte transfer has been completed; 0: Transfer has not been completed.	0
0	RB_SPI_IF_CNT_END	RW1	SPI full byte transfer completion flag bit. Write 1 to reset: 1: All bytes have been transferred; 0: Transfer has not been completed.	1

SPI Transceiver FIFO Count Register (R8_SPIx_FIFO_COUNT) (x=0/1)

Bit	Name	Access	Description	Reset value
[7:0]	R8_SPIx_FIFO_COUNT	RW	The current count of bytes in the FIFO.	00h

SPI Transceiver FIFO Count Register (R8_SPIx_FIFO_COUNT1) (x=0/1)

Bit	Name	Access	Description	Reset value
[7:0]	R8_SPIx_FIFO_COUNT1	RW	The current count of bytes in the FIFO. Same as R8_SPIx_FIFO_COUNT.	00h

SPI Transceiver Data Total Length Register (R16_SPIx_TOTAL_CNT) (x=0/1)

Bit	Name	Access	Description	Reset value
[15:0]	R16_SPIx_TOTAL_CNT	RW	The total number of bytes of SPI data transceiving in the master mode. The lower 12 bits are valid. Up to 4095 bytes can be sent and received at one time when using DMA. Slave mode is not supported.	0000h

SPI Data FIFO Register (R8_SPIx_FIFO) (x=0/1)

Bit	Name	Access	Description	Reset value
[7:0]	R8_SPIx_FIFO	RO/WO	Data FIFO register.	XXh

Register R8_SPIx_BUFFER and Register R8_SPIx_FIFO are all SPI data-related registers. The main differences are:

The read of R8_SPIx_BUFFER is the last data exchanged through SPI and does not affect FIFO and R8_SPIx_FIFO_COUNT. When R8_SPIx_BUFFER is written in the master mode, the byte is directly sent, and the operation of writing in the slave mode is undefined;

The read of R8_SPIx_FIFO is the earliest exchanged data taken from the FIFO, which will reduce the FIFO and R8_SPIx_FIFO_COUNT.

To write R8_SPIx_FIFO, data is temporarily stored in the FIFO. In the slave mode, the external SPI master decides

when to take it. In the master mode, data transmission is automatically started when R16_SPIx_TOTAL_CNT is not 0.

SPI0 DMA Buffer Zone Current Address (R16_SPI0_DMA_NOW)

Bit	Name	Access	Description	Reset value
[15:0]	R16_SPI0_DMA_NOW	RW	The current address of the DMA data buffer zone. It can be used to calculate the number of conversions. The calculation method: COUNT = SPI0_DMA_NOW - SPI0_DMA_BEG.	XXXXh

SPI0 DMA Buffer Zone Start Address (R16_SPI0_DMA_BEG)

Bit	Name	Access	Description	Reset value
[15:0]	R16_SPI0_DMA_BEG	RW	The start address of the DMA data buffer zone. Only the lower 15 bits are valid.	XXXXh

SPI0 DMA Buffer Zone End Address (R16_SPI0_DMA_END)

Bit	Name	Access	Description	Reset value
[15:0]	R16_SPI0_DMA_END	RW	The end address of the DMA data buffer zone (not included). Only the lower 15 bits are valid.	XXXXh

10.3 SPI transport format

SPI supports two transport formats: Mode 0 and Mode 3, which are selected by setting RB_SPI_MST_SCK_MOD of R8_SPIx_CTRL_MOD. Always sample and input serial data at SCK rising edge, and output serial data at falling edge.

The formats of data transmission are as shown below:

Mode 0: RB_SPI_MST_SCK_MOD = 0

Figure 10-1 模式0时序图 Transport Format of SPI Mode 0

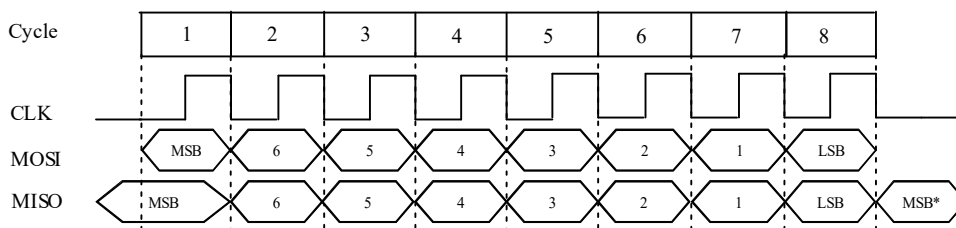

Mode 3: RB_SPI_MST_SCK_MOD = 1

Figure 10-2 模式3时序图 Transport Format of SPI Mode 3

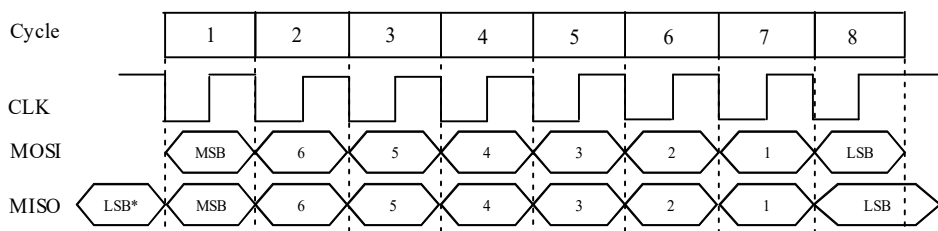

10.4 SPI configuration

10.4.1 SPI master mode

In the SPI master mode, a serial clock is generated on the SCK pins and the chip select pins can be designated as any I/O pin. Configuration steps are:

- (1) Set R8_SPIx_CLOCK_DIV, and configure the frequency of SPI clocks;
- (2) Set RB_SPI_MODE_SLAVE of R8_SPIx_CTRL_MOD to 0, and configure SPI in master mode;
- (3) Set RB_SPI_MST_SCK_MOD of R8_SPIx_CTRL_MOD, and select clock idle mode 0 or mode 3;
- (4) Set RB_SPI_FIFO_DIR of R8_SPIx_CTRL_MOD to configure the FIFO direction. If it is 1, FIFO is used for reception; if it is 0, FIFO is used for transmission.
- (5) Set RB_SPI_MOSI_OE and RB_SPI_SCK_OE of R8_SPIx_CTRL_MOD to 1, RB_SPI_MISO_OE to 0, and set GPIO direction configuration register (R32_PA/PB_DIR) to make MOSI pins and SCK pins as the output and MISO pins as the input;
- (6) In the 2-wire mode, SCK is unchanged. RB_SPI_MOSI_OE=0. MOSI is not used. Input (same as the 3-wire mode, RB_SPI_MISO_OE=0 and pins are set as the input) and output (RB_SPI_MISO_OE=1 and pins are set as the output) are implemented by MISO half-duplex. Directions are manually switched;
- (7) Optional step. If DMA is enabled, R16_SPI_DMA_BEG should be written to the start address of the transceiver buffer zone, and R16_SPI_DMA_END should be written to the end address (not included). It is recommended to set RB_SPI_DMA_ENABLE after setting RB_SPI_FIFO_DIR. If it is confirmed that R16_SPIx_TOTAL_CNT is 0, RB_SPI_DMA_ENABLE can be first set to 1 to enable DMA feature.

Process of data transmission:

- (1) Set RB_SPI_FIFO_DIR to 0 and the current FIFO direction as the output;
- (2) Write the R16_SPIx_TOTAL_CNT Register, and set the length of the data to be sent;
- (3) Write the R8_SPIx_FIFO Register and write the data to be sent to FIFO. If R8_SPIx_FIFO_COUNT is less than the FIFO capacity, continue to write FIFO. If DMA is enabled, DMA automatically loads the FIFO to complete this step.
- (4) As long as R16_SPIx_TOTAL_CNT is not 0 and there is data in the FIFO, the SPI master will automatically send the data, otherwise it will pause;
- (5) Wait for the R16_SPIx_TOTAL_CNT register to be 0, indicating that the data transmission is completed. If only one byte is sent, you can also query and wait for RB_SPI_FREE to be idle, or wait for R8_SPIx_FIFO_COUNT to be 0.

Process of data reception:

- (1) Set RB_SPI_FIFO_DIR to 1 and the current FIFO direction as the input;
- (2) Write the R16_SPIx_TOTAL_CNT register and set the length of the data to be received;
- (3) As long as R16_SPIx_TOTAL_CNT is not 0 and the FIFO is not full, the SPI master will automatically receive the data, otherwise it will pause;
- (4) Wait for the R8_SPIx_FIFO_COUNT register not to be 0, indicating that the return data is received. The value in the R8_SPIx_FIFO is the received data. If DMA is enabled, DMA automatically reads the FIFO to complete this step.

10.4.2 SPI slave mode

SPI0 supports the slave mode. In the slave mode, SCK pins are used to receive the serial clock of an externally connected SPI master. Configuration steps are:

- (1) Set RB_SPI_MODE_SLAVE of R8_SPI0_CTRL_MOD to 1, and configure SPI0 to be slave mode;
- (2) Set RB_SPI_SLV_CMD_MOD of R8_SPI0_CTRL_MOD as needed and select the slave first byte mode or the data stream mode;
- (3) Set the RB_SPI_FIFO_DIR of R8_SPI0_CTRL_MOD to configure the FIFO direction (1: FIFO is used to receive; 0: FIFO is used to send);
- (4) Set RB_SPI_MOSI_OE and RB_SPI_SCK_OE of R8_SPI0_CTRL_MOD to 0, RB_SPI_MISO_OE to 1, and set GPIO direction configuration register (R32_PA/PB_DIR) to make MOSI pins, SCK pins and SCS pins as the input, MISO pins as the input (the connection of multiple slaves is supported under the bus. After chip selection, MISO will automatically switch to output. One master and one slave are also supported) or the output (only for the connection of one master and one slave). In the SPI slave mode, the MISO's I/O pin direction also supports the automatic switching to output during the period when the SPI chip selection is valid, in addition to being able to be set as output by the GPIO direction configuration register. However, its output data

is selected by RB_SPI_MISO_OE (1: SPI data is the output; 0: The data of the GPIO data output register is the output). It is recommended to set the MISO pins as an input so that MISO does not output when chip selection is invalid, which is convenient for sharing the SPI bus during multi-machine operation;

- (5) Optional step. Set the preset data register R8_SPI0_SLAVE_PRE in the SPI0 slave mode, which is used for the first automatic loading in the buffer zone for external output after chip selection. After 8 clocks have passed (that is, the first data byte is exchanged between the master and the slave), the controller obtains the first byte data (command code) sent by the external SPI master, and the external SPI master exchange obtains the preset data (status value) in R8_SPI0_SLAVE_PRE. Bit 7 of R8_SPI0_SLAVE_PRE will be automatically loaded onto the MISO pins during SCK low level after SPI chip select is valid. For SPI Mode 0 (CLK is at low level by default), if Bit 7 of R8_SPI0_SLAVE_PRE is preset, the external SPI master will be able to get the preset value of Bit 7 of R8_SPI0_SLAVE_PRE by querying the MISO pins when the SPI chip select is valid but has not yet transferred data. In this way, the value of Bit 7 of R8_SPI0_SLAVE_PRE can be quickly obtained by only validating the SPI chip select (usually, a busy status is provided to the master, so that the master can conduct quick query);
- (6) Optional step. If DMA is enabled, R16_SPI_DMA_BEG should be written to the start address of the send/reception buffer zone, and R16_SPI_DMA_END should be written to the end address (not included). RB_SPI_DMA_ENABLE must be set after RB_SPI_FIFO_DIR is set.

Process of data transmission:

- (1) Set the RB_SPI_FIFO_DIR of R8_SPI0_CTRL_MOD to 0 and the current FIFO direction as the output;
- (2) Optional step. If DMA is enabled, set RB_SPI_DMA_ENABLE to 1 and enable DMA function;
- (3) Write multiple transmit data into the FIFO Register R8_SPI0_FIFO, and the time of taking away data is determined by the external SPI master. If DMA is enabled, DMA automatically loads FIFO to complete this step;
- (4) Query R8_SPI0_FIFO_COUNT. If it is not full, continue to write the data to be sent to the FIFO.

Process of data acceptance:

- (1) Set the RB_SPI_FIFO_DIR of R8_SPI0_CTRL_MOD to 1 and the current FIFO direction as the input;
- (2) Optional step. If DMA is enabled, set RB_SPI_DMA_ENABLE to 1, and enable DMA function;
- (3) Query R8_SPI0_FIFO_COUNT, if it is not empty, it indicates that the data has been received. The data is taken by reading R8_SPI0_FIFO. If DMA is enabled, the DMA automatically reads the FIFO to complete this step;
- (4) For the reception of single byte data, R8_SPIx_BUFFER can also be directly read without using FIFO.

10.5 SPI timing

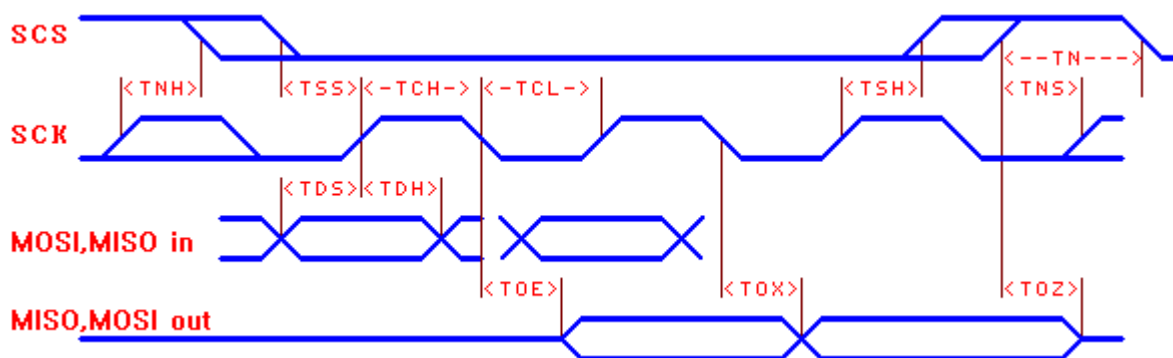

Name	Parameter description (TA=25°C, VIO33=3.3V)	Min.	Typ.	Max.	Unit
TSS	Setup time of valid SCS before SCK rising edge	Tsys*1.05			nS
TSH	Hold time of valid SCS after SCK rising edge	Tsys*1.05			nS
TNS	Setup time of invalid SCS before SCK rising edge	15			nS
TNH	Hold time of invalid SCS after SCK rising edge	15			nS

TN	Time of invalid SCS (interval time of SPI operation)	$T_{sys} * 2$			nS
TCH	Time of SCK clock at high level	$T_{sys} * 0.55$			nS
TCL	Time of SCK clock at low level	$T_{sys} * 0.55$			nS
TDS	Setup time of MOSI/MISO input before SCK rising edge	8			nS
TDH	Hold time of MOSI/MISO input after SCK rising edge	5			nS
TOE	SCK falling edge to MISO/MOSI output valid	0		18	nS
TOX	SCK falling edge to MISO/MOSI output change	0	5	16	nS
TOZ	SCS invalid to MISO/MOSI output invalid	2		24	nS

Note: T_{sys} is the clock cycle of system domain frequency ($1/F_{sys}$).

Chapter 11 PWM

11.1 PWM controller introduction

In addition to the 4-channel 26-bit PWM outputs provided by the timer, the system also provides 8-channel 8-bit PWM output (PWM4 to PWM11) with an adjustable duty ratio and 8 optional cycles as the fixed PWM period for easy operation.

11.2 Register Description

Table 11-1 List of PWMx-related registers

Name	Access address	Description	Reset value
R8_PWM_OUT_EN	0x40005000	PWMx output enable register	0x00
R8_PWM_POLAR	0x40005001	PWMx output polarity configuration register	0x00
R8_PWM_CONFIG	0x40005002	PWMx Configuration Control Register	0x0X
R8_PWM_CLOCK_DIV	0x40005003	PWMx clock divider register	0x00
R32_PWM4_7_DATA	0x40005004	PWM4/5/6/7 data holding register	0xFFFFFFFF
R8_PWM4_DATA	0x40005004	PWM4 data holding register	0xFF
R8_PWM5_DATA	0x40005005	PWM5 data holding register	0xFF
R8_PWM6_DATA	0x40005006	PWM6 data holding register	0xFF
R8_PWM7_DATA	0x40005007	PWM7 data holding register	0xFF
R32_PWM8_11_DATA	0x40005008	PWM8/9/10/11 data holding register	0xFFFFFFFF
R8_PWM8_DATA	0x40005008	PWM8 data holding register	0xFF
R8_PWM9_DATA	0x40005009	PWM9 data holding register	0xFF
R8_PWM10_DATA	0x4000500A	PWM10 data holding register	0xFF
R8_PWM11_DATA	0x4000500B	PWM11 data holding register	0xFF

PWMx Output Enable Register (R8_PWM_OUT_EN)

Bit	Name	Access	Description	Reset value
7	RB_PWM11_OUT_EN	RW	PWM11 output enable bit: 1: Enable; 0: Disable.	0
6	RB_PWM10_OUT_EN	RW	PWM10 output enable bit: 1: Enable; 0: Disable.	0
5	RB_PWM9_OUT_EN	RW	PWM9 output enable bit: 1: Enable; 0: Disable.	0
4	RB_PWM8_OUT_EN	RW	PWM8 output enable bit: 1: Enable; 0: Disable.	0
3	RB_PWM7_OUT_EN	RW	PWM7 output enable bit: 1: Enable; 0: Disable.	0
2	RB_PWM6_OUT_EN	RW	PWM6 output enable bit: 1: Enable; 0: Disable.	0
1	RB_PWM5_OUT_EN	RW	PWM5 output enable bit: 1: Enable; 0: Disable.	0

0	RB_PWM4_OUT_EN	RW	PWM4 output enable bit: 1: Enable; 0: Disable.	0
---	----------------	----	---	---

PWMx Output Polarity Configuration Register (R8 PWM_POLAR)

Bit	Name	Access	Description	Reset value
7	RB_PWM11_POLAR	RW	PWM11 output polarity control bit: 1: Default at high level, valid at low level; 0: Default at low level, valid at high level;	0
6	RB_PWM10_POLAR	RW	PWM10 output polarity control bit: 1: Default at high level, valid at low level; 0: Default at low level, valid at high level;	0
5	RB_PWM9_POLAR	RW	PWM9 output polarity control bit: 1: Default at high level, valid at low level; 0: Default at low level, valid at high level;	0
4	RB_PWM8_POLAR	RW	PWM8 output polarity control bit: 1: Default at high level, valid at low level; 0: Default at low level, valid at high level;	0
3	RB_PWM7_POLAR	RW	PWM7 output polarity control bit: 1: Default at high level, valid at low level; 0: Default at low level, valid at high level;	0
2	RB_PWM6_POLAR	RW	PWM6 output polarity control bit: 1: Default at high level, valid at low level; 0: Default at low level, valid at high level;	0
1	RB_PWM5_POLAR	RW	PWM5 output polarity control bit: 1: Default at high level, valid at low level; 0: Default at low level, valid at high level;	0
0	RB_PWM4_POLAR	RW	PWM4 output polarity control bit: 1: Default at high level, valid at low level; 0: Default at low level, valid at high level;	0

PWMx Configuration Control Register (R8 PWM_CONFIG)

Bit	Name	Access	Description	Reset value
7	RB_PWM10_11_STAG_EN	RW	PW10/11 interleaved output enable bit: 1: Interleaved output; 0: Independent output.	0
6	RB_PWM8_9_STAG_EN	RW	PW8/9 interleaved output enable bit: 1: Interleaved output; 0: Independent output.	0
5	RB_PWM6_7_STAG_EN	RW	PW6/7 interleaved output enable bit: 1: Interleaved output; 0: Independent output.	0
4	RB_PWM4_5_STAG_EN	RW	PW4/5 interleaved output enable bit: 1: Interleaved output; 0: Independent output.	0
[3:2]	RB_PWM_CYC_MOD	RW	Select the width of PWM data: 00: 8-bit data width; 01: 7-bit data width; 10: 6-bit data width; 11: 5-bit data width.	00b

1	RB_PWM_STAG_ST	RO	PWM interleave flag bit: 1: Indicating that PWM5/7/9/11 is allowed to output; 0: Indicating that PWM4/6/8/10 is allowed to output;	X
0	RB_PWM_CYCLE_SEL	RW	Select PWM cycle matching PWM data width: 1: 255/127/63/31 clock cycles; 0: 256/128/64/32 clock cycles.	0

PWMx Clock Divider Register (R8_PWM_CLOCK_DIV)

Bit	Name	Access	Description	Reset value
[7:0]	R8_PWM_CLOCK_DIV	RW	PWM reference clock division factor. $F_{pwm} = F_{sys} / R8_PWM_CLOCK_DIV$.	00h

PWM Data Holding Register Set 1 (R32_PWM4_7_DATA)

Bit	Name	Access	Description	Reset value
[31:24]	R8_PWM7_DATA	RW	PWM7 data holding register.	XXb
[23:16]	R8_PWM6_DATA	RW	PWM6 data holding register.	XXb
[15:8]	R8_PWM5_DATA	RW	PWM5 data holding register.	XXb
[7:0]	R8_PWM4_DATA	RW	PWM4 data holding register.	XXb

PWM Data Holding Register Set 2 (R32_PWM8_11_DATA)

Bit	Name	Access	Description	Reset value
[31:24]	R8_PWM11_DATA	RW	PWM11 data holding register.	XXb
[23:16]	R8_PWM10_DATA	RW	PWM10 data holding register.	XXb
[15:8]	R8_PWM9_DATA	RW	PWM9 data holding register.	XXb
[7:0]	R8_PWM8_DATA	RW	PWM8 data holding register.	XXb

11.3 PWM configuration

- (1) Set Register R8_PWM_CLOCK_DIV and configure the reference clock frequency of PWM;
- (2) Set the PWM output polarity configuration register R8_PWM_POLAR, and configure the output polarity corresponding to PWMx;
- (3) Set the PWM configuration control register R8_PWM_CONFIG, and set the PWM mode, data bit width and period;
- (4) Set the PWM output enable register R8_PWM_OUT_EN and enable the corresponding PWMx output;
- (5) Calculate the data according to the required duty cycle, and write into the corresponding data holding register R8_PWMx_DATA;
- (6) Set the PWM pin direction required in PWM4-PWM11 as the output. Optionally set the drive capability of the corresponding I/O.
- (7) Update the data in R8_PWMx_DATA as needed and update the output duty cycle.

Adjust the duty cycle of the modifiable output PWM of R8_PWMx_DATA Register. The duty cycle is calculated

as:

$N_{cyc} = RB_PWM_CYCLE_SEL ? (2^{n-1}) : (2^n)$

(n = data bit width), N_{cyc} result is between 63 and 256.

Duty cycle of PWMx output active level = $R8_PWMx_DATA / N_{cyc} * 100\%$

PWMx output frequency, $F_{pwmout} = F_{pwm} / N_{cyc} = F_{sys} / R8_PWM_CLOCK_DIV / N_{cyc}$

If a DC signal needs to be generated via PWM, the PWMx output end can be filtered by R/C and other circuits. It is recommended to use a two-stage RC with a time constant much greater than $4 / F_{pwmout}$, or a first-stage RC with a time constant much greater than $100 / F_{pwmout}$.

Chapter 12 LED Screen Controller

12.1 LED controller introduction

A chip is provided with an LED screen control card interface and built-in 2-byte FIFO, supports DMA and interrupt, saves CPU processing time, and supports 1/2/4 data cable interface.

12.2 Register description

Table 12-1 List of LED-related registers

Name	Access address	Description	Reset value
R8_LED_CTRL_MOD	0x40006400	LED Mode Configuration Register	0x02
R8_LED_CLOCK_DIV	0x40006401	LED Serial Clock Divider Register	0x10
R8_LED_STATUS	0x40006404	LED Status Register	0xX0
R16_LED_FIFO	0x40006408	LED Data FIFO Register	0xXXXX
R16_LED_DMA_CNT	0x40006410	LED DMA Remaining Count Register	0x0000
R16_LED_DMA_MAIN	0x40006414	LED Main Buffer Zone DMA Address	0xXXXX
R16_LED_DMA_AUX	0x40006418	LED Auxiliary Buffer Zone DMA Address	0xXXXX

LED Mode Configuration Register (R8_LED_CTRL_MOD)

Bit	Name	Access	Description	Reset value
[7:6]	RB_LED_CHAN_MOD	RW	Select LED channel mode: 00: LED0, single channel output; 01: LED0/1, dual channel output; 10: LED0~3, 4-channel output; 11: LED0~3, 4-channel output, where LED2/3 channel data is from auxiliary buffer zone.	00b
5	RB_LED_IE_FIFO	RW	Enable half of FIFO count interrupt: 1: FIFO count <=2 interrupt trigger; 0: Interrupt is disabled.	0
4	RB_LED_DMA_EN	RW	Enable LED DMA feature and DMA interrupt: 1: Enable; 0: Disable.	0
3	RB_LED_OUT_EN	RW	Enable LED signal output: 1: Enable; 0: Disable.	0
2	RB_LED_OUT_POLAR	RW	LED data output polarity control bit: 1: Opposition: data 0 output 1 and data 1 output 0; 0: Straight-through: data 0 output 0 and data 1 output 1.	0
1	RB_LED_ALL_CLEAR	RW	Clear LED FIFO/counter/interrupt flag: 1: Force emptying and clearing; 0: No clearing.	1
0	RB_LED_BIT_ORDER	RW	Select LED serial data bit sequence: 1: Low bits are in front; 0: High bits are in front.	0

LED Serial Clock Divider Register (R8_LED_CLOCK_DIV)

Bit	Name	Access	Description	Reset value
-----	------	--------	-------------	-------------

[7:0]	R8_LED_CLOCK_DIV	RW	LED output clock division factor. LEDC frequency = Fsys / R8_LED_CLOCK_DIV.	10h
-------	------------------	----	--	-----

LED Status Register (R8_LED_STATUS)

Bit	Name	Access	Description	Reset value
7	RB_LED_IF_DMA_END	RW1	DMA completion flag bit, write 1 to reset or write R16_LED_DMA_CNT to reset: 1: Has completed; 0: Not completed.	0
6	RB_LED_FIFO_EMPTY	RO	FIFO empty status bit: 1: FIFO is empty; 0: There is data in FIFO.	1
5	RB_LED_IF_FIFO	RW1	Over half of FIFO counts interrupt flag bit, write 1 to reset or write R16_LED_FIFO to reset: 1: FIFO count <=2; 0: FIFO count >2.	0
4	RB_LED_CLOCK	0	Current LED clock signal level status: 1: High level; 0: Low level.	X
3	Reserved	RO	Reserved	0
[2:0]	RB_LED_FIFO_COUNT	RO	The value of byte count in the current FIFO must be an even number.	000b

LED Data FIFO Register (R16_LED_FIFO)

Bit	Name	Access	Description	Reset value
[15:0]	R16_LED_FIFO	WO	LED data FIFO entry, 16-bit write.	XXXXb

LED DMA Remaining Count Register (R16_LED_DMA_CNT)

Bit	Name	Access	Description	Reset value
[15:0]	R16_LED_DMA_CNT	RW	The current DMA remaining words (16 bits) count of the LED_DMA_MAIN main buffer zone automatically decrements after DMA startup. Only the lower 12 bits are valid. The auxiliary buffer zone is not included.	0000b

LED Main Buffer Zone DMA Address (R16_LED_DMA_MAIN)

Bit	Name	Access	Description	Reset value
[15:0]	R16_LED_DMA_MAIN	RW	DMA start address / current address of the main buffer zone automatically increment after the initial value is preset and they must be 2 bytes aligned.	XXXXb

LED Auxiliary Buffer Zone DMA Address (R16_LED_DMA_AUX)

Bit	Name	Access	Description	Reset value
[15:0]	R16_LED_DMA_AUX	RW	DMA start address / current address of the auxiliary buffer zone automatically increment after the initial value is preset and they must be 2 bytes aligned.	XXXXb

12.3 LED configuration

- (1) Set R8_LED_CLOCK_DIV to select the LED output clock frequency;
- (2) Set R16_LED_DMA_MAIN to point to the buffer zone that prepares the output data, that is, the main buffer zone;
- (3) If LED channel mode 3 is selected, set R16_LED_DMA_AUX to point to the auxiliary buffer zone;

- (4) Set R8_LED_CTRL_MOD, select the channel mode, output polarity, bit order, enable interrupt and DMA feature, etc.;
- (5) Set LEDC and necessary LED0~LED3 pin direction as the output, and optionally set the corresponding I/O drive capability;
- (6) Set the DMA count register R16_LED_DMA_CNT, start DMA send, or send data by writing FIFO.

Chapter 13 Segment LCD

13.1 Segment LCD control introduction

A chip is provided with a segment LCD controller interface that supports 96-point (24x4) LCD panels, adjustable drive voltage, adjustable scanning frequency, and LCD with specifications of 1/2 duty, 1/3 duty, 1/4 duty and 1/3 bias, and 1/2 bias.

13.2 Register description

Table 13-1 List of LCD-related registers

Name	Access address	Description	Reset value
R8_LCD_CTRL_MOD	0x40006000	LCD Mode Configuration Register	0x00
R32_LCD_RAM0	0x40006004	LCD Data Register Set 0	0x00000000
R32_LCD_RAM1	0x40006008	LCD Data Register Set 1	0x00000000
R32_LCD_RAM2	0x4000600C	LCD Data Register Set 2	0x00000000

LCD Mode Configuration Register (R8_LCD_CTRL_MOD)

Bit	Name	Access	Description	Reset value
7	RB_LCD_V_SEL	WO	Select LCD drive voltage: 1: VIO33*76% (2.5V); 0: VIO33*100% (3.3V).	0
[6:5]	RB_LCD_SCAN_CLK	RW	Select LCD scan clock frequency: 00: 256Hz; 01: 512Hz; 10: 1KHz; 11: 128Hz.	00b
[4:3]	RB_LCD_DUTY	RW	Select LCD driver duty: 00: 1/2 duty (COM0-COM1); 01: 1/3 duty (COM0-COM2); 10: 1/4 duty (COM0-COM3).	00b
2	RB_LCD_BIAS	RW	LCD driver bias selection bit: 1: 1/3 bias; 0: 1/2 bias.	0
1	RB_LCD_POWER_ON	RW	LCD analog circuit enable bit: 1: Enable; 0: Disable.	0
0	RB_SYS_POWER_ON	RW	LCD logic circuit enable bit: 1: Enable; 0: Disable.	0

LCD Data Register Set 0 (R32_LCD_RAM0)

Bit	Name	Access	Description	Reset value
[31:0]	R32_LCD_RAM0	RW	Data of segments SEG0-SEG7, 4 bits at each segment.	00000000h

LCD Data Register Set 1 (R32_LCD_RAM1)

Bit	Name	Access	Description	Reset value
[31:0]	R32_LCD_RAM1	RW	Data of segments SEG8-SEG15, 4 bits at each segment.	00000000h

LCD Data Register Set 2 (R32_LCD_RAM2)

Bit	Name	Access	Description	Reset value
[31:0]	R32_LCD_RAM2	RW	Data of segments SEG16-SEG23, 4 bits at each segment.	00000000h

13.3 Segment LCD configuration

- (1) Select and turn on the 32KHz clock source;
- (2) Set the LCD driver pins to be used as floating input. Optionally set R16_PIN_ANALOG_IE to save system power consumption. Note that external reset RST# multiplexes LCD driver pin SEG23. If SEG23 is to be used, cancel the feature of external reset;
- (3) Load the segment code data to be displayed to the LCD data register R32_LCD_RAM0/1/2;
- (4) Configure R8_LCD_CTRL_MOD, set the driving voltage, scanning frequency, bias, duty and other parameters, and set RB_LCD_POWER_ON and RB_SYS_POWER_ON, turn on the segment LCD driver;
- (5) Update the LCD data register to display different contents at any time.

Chapter 14 Passive Parallel Port

14.1 Passive parallel port introduction

A chip is provided with a passive parallel port with eight bidirectional data cables (PB7~PB0), four input control lines (SLVS/SLVW/SLVR/SLVA) and one output interrupt request line (SLVI). Among them, SLVS is chip select active at low level; SLVW/SLVR control write and read respectively, SLVA=0 means that data is operated; SLVA=1 means that a command or status is operated.

Table 14-1 Passive Parallel I/O Operation

SLVS	SLVW	SLVR	SLVA	PB7~PB0	Operation
1	X	X	X	Tri-state disable	Unselected, no action
0	1	1	X	Tri-state disable	Selected, but no action
0	0	1/X	1	Input status	Write a command to CH579 with the command in R8_SLV_WR_DATA
0	0	1/X	0	Input status	Write data to CH579 with the data in R8_SLV_WR_DATA
0	1	0	1	Output status	Read a status from CH579 with the status from R8_SLV_RD_STAT
0	1	0	0	Output status	Read data from CH579 with the data from R8_SLV_RD_DATA

Register R8_SLV_WR_DATA is a multiplex of the R16_PB_INT_MODE high bytes. Register R8_SLV_RD_STAT and Register R8_SLV_RD_DATA are multiplexed with the R16_PB_INT_MODE low byte and R8_PB_OUT_0. Therefore, the feature of the multiplexed module will not be available after the passive parallel port is enabled.

The interrupt request output SLVI is the "logic OR" of R8_SLV_RD_STAT[7] and R8_PA_OUT_0[3]. When either of them is 1, output is at the high level by default. When both of them are 0, an interrupt request active at low level is output.

14.2 Register description

Table 14-2 List of registers related to passive parallel ports

Name	Access address	Description	Reset value
R8_SLV_CONFIG	0x4000101C	Passive parallel port configuration register	0x00
R8_SLV_RD_DATA	0x400010C8	Passive parallel port read data register	0x00
R8_SLV_RD_STAT	0x40001096	Passive parallel port read status register	0x00
R8_SLV_WR_DATA	0x40001097	Passive parallel port write data / command register	0x00

Passive parallel port configuration register (R8_SLV_CONFIG)

Bit	Name	Access	Description	Reset value
7	RB_IF_SLV_RD	RW1	Data read interrupt flag bit. Write 1 to reset to 0: 1: A read event is detected; 0: No event.	0
6	RB_IF_SLV_WR	RW1	Data written interrupt flag bit. Write 1 to reset to 0: 1: A read event is detected; 0: No event.	0
5	RB_IF_SLV_CMD	RO	Command written flag: 1: A command is currently written; 0: No write-in currently or data is written.	0
4	Reserved	RO	Reserved	0

3	RB_SLV_IE_RD	RW	Data read interrupt enable bit: 1: Enable; 0: Disable.	0
2	RB_SLV_IE_WR	RW	Data write interrupt enable bit: 1: Enable; 0: Disable.	0
1	RB_SLV_IE_CMD	RW	Command write interrupt enable bit: 1: Enable; 0: Disable.	0
0	RB_SLV_ENABLE	RW	Passive parallel port enable bit: 1: Enable; 0: Disable.	0

14.3 Passive parallel port configuration

- (1) Optional step. In order to enable the SLVI interrupt output, the status value must first be preset in R8_SLV_RD_STAT. Especially, R8_SLV_RD_STAT[7] associated with the SLVI interrupt pins should be set to 1. Clear R8_PA_OUT_0[3];
- (2) Set the GPIO pins corresponding to SLVA (PA0), SLVS (PA1), SLVR (PB8) and SLVW (PB9) to the pull-up input (recommended) or the floating input mode, and set PB7~PB0 pins as the pull-up input (recommended) or the floating input mode;
- (3) Set the RB_SLV_ENABLE of R8_SLV_CONFIG to enable the passive parallel port;
- (4) Optional step. In order to enable the SLVI interrupt output, set the GPIO pins corresponding to SLVA (PA3) as the output;
- (5) Optional step. Enable the passive parallel port interrupt response as required, combine RB_SLV_IE_RD/RB_SLV_IE_WR/RB_SLV_IE_CMD, and configure the corresponding channel enable of the core NVIC. It is recommended to enable only RB_SLV_IE_CMD;
- (6) Optional step. The data to be sent is preset in R8_SLV_RD_DATA;
- (7) Optional step. If the SLVI interrupt output is enabled and an interrupt request is required to output at low level via SLVI, the preset status value in R8_SLV_RD_STAT can be updated and R8_SLV_RD_STAT[7] is set to 0. If an interrupt request needs to be canceled, resume SLVI to the default high level, then set R8_SLV_RD_STAT[7] to 1 or set R8_PA_OUT_0[3] to 1;
- (8) After the written command is interrupt or RB_IF_SLV_WR is queried as valid, when RB_IF_SLV_CMD is 1, the written command code is obtained from R8_SLV_WR_DATA. When RB_IF_SLV_CMD is 0, the written data is obtained from R8_SLV_WR_DATA;
- (9) After RB_IF_SLV_RD is queried as valid, the next data or status can be preset.

Chapter 15 Analog to Digital Converter (ADC)

15.1 ADC introduction

A chip is provided with a 12-bit successive approximation type analog-to-digital converter (ADC) that provides up to 16 channels and supports 14 external signal sources and 2 internal signal sources.

15.1.1 Main features

- 12-bit resolution.
- 14 external voltage sampling channels, internal temperature detection channels, internal battery voltage detection channel.
- Detection in the single-ended input mode and the differential input mode.
- The sampling clock frequency is optional.
- The range of ADC input voltage is 0V~VIO33.
- PGA is optional. Gain adjustment options are provided.
- Input buffer BUF is optional. High resistance signal sources are supported.

15.1.2 Function description

The figure below is a block diagram of an ADC module.

Figure 15-1 ADC structure diagram

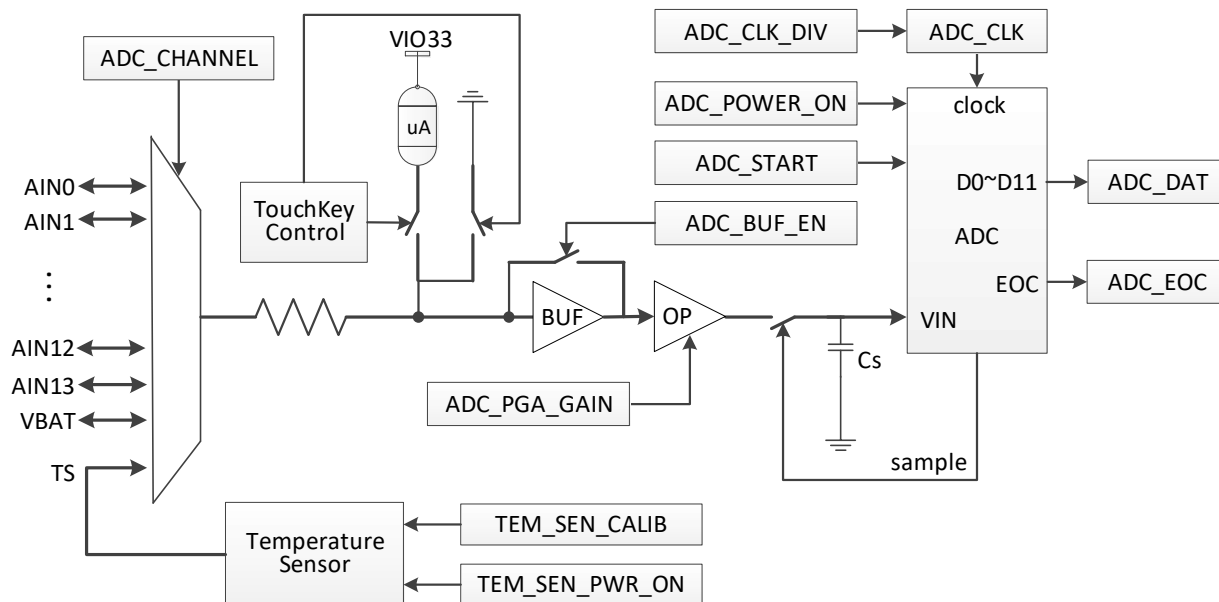

15.2 Register description

Table 15-1 List of ADC-related registers

Name	Access address	Description	Reset value
R8_ADC_CHANNEL	0x40001058	ADC input channel select register	0x0F
R8_ADC_CFG	0x40001059	ADC configuration register	0xA0
R8_ADC_CONVERT	0x4000105A	ADC conversion control register	0x00
R8_TEM_SENSOR	0x4000105B	Temperature sensor control register	0x04
R16_ADC_DATA	0x4000105C	ADC data register	0x0XXX
R8_ADC_INT_FLAG	0x4000105E	ADC interrupt flag register	0x00

ADC Input Channel Select Register (R8_ADC_CHANNEL)

Bit	Name	Access	Description	Reset value
[7:4]	Reserved	RO	Reserved	0000b
[3:0]	RB_ADC_CH_INX	RW	ADC channel index number. A total of 16 channels: 00h-0Dh: External signal channel AIN0~AIN13; 0Eh: Battery voltage VBAT; 0Fh: Built-in temperature sensor TS.	1111b

ADC Configuration Register (R8_ADC_CFG)

Bit	Name	Access	Description	Reset value
[7:6]	RB_ADC_CLK_DIV	RW	Select ADC clock frequency: 00: CK32M-based 10 fractional frequency, 3.2MHz; 01: CK32M-based 12 fractional frequency, 2.67MHz; 10: CK32M-based 6 fractional frequency, 5.33MHz; 11: CK32M-based 8 fractional frequency, 4MHz. The actual sampling rate is approximately 1/16 of the clock frequency.	10b
[5:4]	RB_ADC_PGA_GAIN	RW	Select ADC's input PGA gain: 00: -12dB, 1/4 times; 01: -6dB, 1/2 times; 10: 0dB, 1x, no gain; 11: 6dB, 2 times.	10b
3	RB_ADC_OFS_TEST	RW	ADC offset error test mode: 1: Test mode (only supported by channel 1). In the test mode, the low 12 bits data of the data register R16_ADC_DATA will be inverted by bits (0x0579 is inverted as 0x0A86); 0: Normal mode.	0
2	RB_ADC_DIFF_EN	RW	ADC channel signal input mode: 1: Differential input; 0: Single-ended input.	0
1	RB_ADC_BUF_EN	RW	ADC Input buffer BUF enable: 1: On; 0: Off.	0
0	RB_ADC_POWER_ON	RW	ADC module power enable control: 1: Enable; 0: Disable.	0

Table 15-2 PGA Gain Selection and Input Voltage Range Table

PGA Gain Selection	The sampled voltage, V_i , is calculated from the ADC converted data	Upper limit of theoretically measurable voltage	Theoretically measurable voltage range (assuming $V_{ref} = 1.05V$)	Recommended range of practical measurement voltage
-12dB (1/4 times)	$(ADC/512-3)*V_{ref}$	$5*V_{ref}$	-0.2V ~ $V_{IO33}+0.2V$	2.9V ~ V_{IO33}
-6dB (1/2 times)	$(ADC/1024-1)*V_{ref}$	$3*V_{ref}$	-0.2V ~ 3.15V	1.9V ~ 3V
0dB (1 times)	$(ADC/2048)*V_{ref}$	$2*V_{ref}$	0V ~ 2.1V	0V ~ 2V
6dB (2 times)	$(ADC/4096+0.5)*V_{ref}$	$1.5*V_{ref}$	0.525V ~ 1.575V	0.6V ~ 1.5V

ADC: The digital quantity after ADC conversion, namely R16_ADC_DATA.

Vref: The actual voltage value of the power supply node VINTA of the internal analog circuit is usually $1.05V \pm 0.02V$.

Note: If sampling is taken at a low voltage after a negative gain (signal reduction), it may cause a large error in a voltage range; if sampling is taken at a high voltage after a positive gain (signal amplification), it may cause the conversion value of ADC to overflow. For this reason, it is recommended to select a reasonable gain mode based on the range of the measured signal voltage.

It is recommended to turn on the input buffer by default. The input buffer can be turned off to conduct ADC only when the internal resistance of the external signal source is less than $1K\Omega$.

When differential input is used, it is recommended to turn off the input buffer. When it is used for TouchKey detection, the input buffer must be turned on, and one of the two types of gains, either 0dB (priority) or -6dB, is recommended.

ADC Conversion Control Register (R8_ADC_CONVERT)

Bit	Name	Access	Description	Reset value
7	RB_ADC_EOC_X	RO	ADC conversion end flag (asynchronous signal): 1: Complete; 0: In progress.	0
6	Reserved	RO	Reserved	0
5	RB_TKEY_CHG_ACT	RO	TouchKey capacitor charging status: 1: Capacitor charging; 0: Not charging.	0
4	RB_TKEY_ACTION	RO	TouchKey operation status: 1: Charging or discharging or ADC conversion; 0: Idle state.	0
3	RB_TKEY_PWR_ON	RW	TouchKey module power enable control: 1: Enable; 0: Disable.	0
[2:1]	Reserved	RO	Reserved	00b
0	RB_ADC_START	RW	ADC conversion start control and status, automatic reset to zero: 1: Start conversion/converting; 0: Stop conversion.	0

Temperature Sensor Control Register (R8_TEM_SENSOR)

Bit	Name	Access	Description	Reset value
7	RB_TEM_SEN_PWR_ON	RW	Control TS temperature sensor power enable: 1: Enable; 0: Disable.	0
[6:3]	Reserved	RW	Reserved	0000b
[2:0]	RB_TEM_SEN_CALIB	RW	TS temperature sensor calibration value needs to remain unchanged.	100b

ADC Data Register (R16_ADC_DATA)

Bit	Name	Access	Description	Reset value
[15:12]	Reserved	RW	Reserved	0000b
[11:0]	RB_ADC_DATA	RO	Data after ADC conversion.	XXXh

ADC Interrupt Flag Register (R8_ADC_INT_FLAG)

Bit	Name	Access	Description	Reset value
7	RB_ADC_IF_EOC	RO	ADC conversion completion interrupt flag. This flag can be cleared by writing to register R8_ADC_CONVERT.	0
[6:0]	Reserved	RW	Reserved	0000000b

15.3 ADC configuration

15.3.1 External channel sampling

- (1) Set RB_ADC_POWER_ON of R8_ADC_CFG to 1 to turn on the ADC, select the sampling frequency via RB_ADC_CLK_DIV, enable the input buffer and select the signal gains via RB_ADC_BUF_EN and RB_ADC_PGA_GAIN;
- (2) Set R8_ADC_CHANNEL Register and select an external or internal signal channel;
- (3) Set R8_ADC_CONVERT Register, set RB_ADC_START, and start ADC conversion;
- (4) Query and wait for RB_ADC_START to automatically reset to zero or wait for RB_ADC_IF_EOC to be set to 1, indicating that the conversion is complete. Read R16_ADC_DATA to get 12-bit ADC conversion data. When there is enough time, it is recommended to convert and discard the first ADC data again;
- (5) Repeat Step 2, Step 3 and Step 4. Continue to sample another channel or the next set of data.
- (6) One ADC conversion cycle: ADC sampling (4 clocks) + conversion time (12 clocks) $\approx 16 T_{adc}$. 1 time interval is added at time of continuous ADC, where $T_{adc} = T_{sys} @ RB_ADC_CLK_DIV$.
- (7) If differential input is used:
 Enable differential, select 0# channel: Actually conduct differential signal conversion on the voltage of AIN0 (positive end) and AIN2 (negative end);
 Enable differential, select 1# channel: Actually conduct differential signal conversion on the voltage of AIN1 (positive end) and AIN3 (negative end);
 In terms of the result after ADC conversion, if the data is greater than 0x800, it is indicated that the voltage of differential positive end is higher than that of differential negative end; if the data is less than 0x800, it is indicated that the voltage of differential positive end is lower than that of differential negative end. Taking PGA gain selection 0dB as an example, the theoretically measurable voltage range is -1.05V~1.05V. 0x400 means that the voltage of differential positive end is lower than that of differential negative end by about 0.5 Vref.

15.3.2 Temperature sensor sampling

- (1) Set the RB_TEM_SEN_PWR_ON of the R8_TEM_SENSOR Register to 1 and turn on the temperature sensor, set R8_ADC_CHANNEL to 15, and select the temperature sensor signal to connect to the ADC input;
- (2) Set RB_ADC_POWER_ON to 1 to turn on the ADC, reset RB_ADC_DIFF_EN, set RB_ADC_CLK_DIV, set RB_ADC_BUF_EN to 1, and set RB_ADC_PGA_GAIN to 0dB gain;
- (3) Set the R8_ADC_CONVERT Register, set RB_ADC_START to 1, and start ADC conversion;
- (4) Query and wait for RB_ADC_START to automatically reset to zero or wait for RB_ADC_IF_EOC to set as 1, read R16_ADC_DATA to obtain 12-bit ADC conversion data. In case of high requirements for accuracy, it is recommended to repeat Step 3 and Step 4 multiple times to calculate the average value of ADC data;
- (5) The temperature value is obtained according to the conversion relationship of voltage and temperature. For details, please refer to the example program of evaluation board.

Chapter 16 Touch-Key

16.1 Touch-Key introduction

A chip is provided with a capacitance detection module that can be used with the ADC module to implement the feature of capacitive touchkey detection. A total of 14 input channels support capacitance value of touchkey ranging from 10pF to 100pF.

16.2 Register description

Table 16-1 TouchKey Related Register List

Name	Access address	Description	Reset value
R8_TKEY_CTRL	0x4000105A	TouchKey Control Register	0x00
R8_TKEY_CNT	0x4000105F	TouchKey Charge and Discharge Time Configuration Register	0x00

Register R8_TKEY_CTRL is an alias for R8_ADC_CONVERT.

TouchKey Control Register (R8_TKEY_CTRL)

Bit	Name	Access	Description	Reset value
7	RB_ADC_EOC_X	RO	ADC conversion end flag: 1: Completed; 0: In progress.	0
6	Reserved	RO	Reserved	0
5	RB_TKEY_CHG_ACT	RO	TouchKey capacitor charging status: 1: Capacitor charging; 0: Not be charged.	0
4	RB_TKEY_ACTION	RO	TouchKey operation status: 1: Charging or discharging or ADC conversion; 0: Idle state.	0
3	RB_TKEY_PWR_ON	RW	TouchKey module power enable control: 1: Enable; 0: Disable.	0
[2:1]	Reserved	RO	Reserved	00b
0	RB_ADC_START	RW	ADC conversion start control and status, automatic reset to zero: 1: Start conversion/converting; 0: Stop conversion.	0

TouchKey Charge and Discharge Time Configuration Register (R8_TKEY_CNT)

Bit	Name	Access	Description	Reset value
[7:0]	R8_TKEY_CNT	WO	The number of charge and discharge cycles of Touch-Key (in Tsys). The full 8 bits are the number of charge cycles. Recommended not less than 0x10. The number of discharge cycles is automatically generated according to the number of charge cycles. When the number of charging cycles is less than 128, the number of discharging cycles is 8; when the number of charging cycles is greater than or equal to 128, the number of discharging cycles is 14.	00h

16.3 Touch-Key configuration

- (1) Set RB_ADC_POWER_ON to 1 to turn on the ADC, reset RB_ADC_DIFF_EN, set RB_ADC_CLK_DIV, set RB_ADC_BUF_EN to 1, set RB_ADC_PGA_GAIN to 0dB or -6dB gain (the latter is used for smaller capacitance);
- (2) Set RB_TKEY_PWR_ON of R8_TKEY_CTRL to 1, and enable the TouchKey module;
- (3) Set R8_ADC_CHANNEL and select the channel where the target key is located;
- (4) Optional step. If the interrupt mode is used, R8_TKEY_CTRL must be written to reset RB_ADC_IF_EOC the same as Step 2;
- (5) Estimate the target key's capacitance, calculate its charging time, and write the number of charging cycles into the R8_TKEY_CNT register to calculate:
Number of charging cycles of R8_TKEY_CNT = (Ckey + 5pF parasitic) * Vkey / Ikey / Tsys,
(Specifically, in case of 0dB gain, Vkey is recommended to be 1.6V; in case of -6dB gain, Vkey is recommended to be 2.4V; Ikey is about 35uA)
The external capacitance of the touch key is assumed as Ckey=35pF, Fsys=16MHz, so R8_TKEY_CNT=29.
When the calculation result is less than 16, 16 is taken; when it is between 110 and 128, 128 is taken;
- (6) Query and wait for RB_TKEY_ACTION to be 0 (or, if it is cleared before, it can wait for RB_ADC_IF_EOC to be set to 1), read R16_ADC_DATA to obtain 12-bit ADC conversion data, compare with the stored data of the same channel, analyze and judge whether the key is pressed. It is recommended to use software analysis to remove interference;
- (7) Repeat Step 3, Step 4, Step 5 and Step 6. Continue detecting the keys of the next channel.
- (8) If the interrupt mode is used, the following four steps will be repeated in the interrupt service program: 6: read data and make judgment; 4 or 2: clear interrupt flag; 3: select channel; 5: start detection.

Chapter 17 USB Controller

17.1 USB controller introduction

A chip is embedded with the USB master-slave controller and transceiver. The features include:

- Support USB Host function and USB Device function.
- Support USB2.0 full-speed 12Mbps or low-speed 1.5Mbps.
- Support USB control transfer, batch transfer, interrupt transfer, sync/real-time transfer.
- Support up to 64-bytes of data packets, built-in FIFO, interrupts and DMA.

17.2 Register description

USB-related registers are divided into three categories, some of which are multiplexed in the host and device mode.

- (1) USB global registers
- (2) USB device control registers
- (3) USB host control registers

17.2.1 Global register description

Table 17-1 List of USB-related registers (those marked as gray are reset and controlled by RB_UC_RESET_SIE)

Name	Access address	Description	Reset value
R8_USB_TYPE_C_CTRL	0x40008038	USB Type-C Configuration Register	0x00
R8_USB_CTRL	0x40008000	USB Control Register	0x06
R8_USB_INT_EN	0x40008002	USB Interrupt Enable Register	0x00
R8_USB_DEV_AD	0x40008003	USB Device Address Register	0x00
R32_USB_STATUS	0x40008004	USB Status Register	0xXX20XXXX
R8_USB_MIS_ST	0x40008005	USB Miscellaneous Status Register	0xXX
R8_USB_INT_FG	0x40008006	USB Interrupt Flag Register	0x20
R8_USB_INT_ST	0x40008007	USB Interrupt Status Register	0xXX
R8_USB_RX_LEN	0x40008008	USB Receive Length Register	0xXX

USB Type-C Configuration Register

Bit	Name	Access	Description	Reset value
7	RB_UTCC_GP_BIT	RW	USB universal flag bit, user-defined.	0
6	RB_UCC2_PD_EN	RW	Internal 5.1K pull-down resistor for UCC2 pins: 1: Enable; 0: Disable.	0
[5:4]	RB_UCC2_PU_EN	RW	Internal pull-up resistor control bit for UCC2 pins: 00: Internal pull-up resistor is prohibited; 01: Turn on the internal 36K pull-up to provide the default USB current; 10: Turn on the internal 12K pull-up to provide 1.5A current; 11: Turn on the internal 4.7K pull-up to provide 3A current.	00b
3	RB_VBUS_PD_EN	RW	Internal 10K pull-down resistor for VBUS pins: 1: Enable; 0: Disable.	0
2	RB_UCC1_PD_EN	RW	Internal 5.1K pull-down resistor for UCC1 pins: 1: Enable; 0: Disable.	0

[1:0]	RB_UCC1_PU_EN	RW	Internal pull-up resistor control bit for UCC1 pins: 00: Internal pull-up resistor is prohibited; 01: Turn on the internal 36K pull-up to provide the default USB current; 10: Turn on the internal 12K pull-up to provide 1.5A current; 11: Turn on the internal 4.7K pull-up to provide 3A current.	00b
-------	---------------	----	---	-----

The above USB type-C pull-up resistor and pull-down resistor are independent of the port pull-up resistor controlled by the GPIO port direction control and pull-up resistor enable register. When a pin is used for USB type-C, the port pull-up resistor corresponding to this pin should be disabled. It is recommended to enable the high-impedance input mode for this pin (to avoid this pin output at low or high level).

USB Control Register (R8 USB_CTRL)

Bit	Name	Access	Description	Reset value
7	RB_UC_HOST_MODE	RW	USB working mode selection bit: 1: Host mode; 0: Device mode.	0
6	RB_UC_LOW_SPEED	RW	USB bus signal transmission rate selection bit: 1: 1.5Mbps; 0: 12Mbps.	0
5	RB_UC_DEV_PU_EN	RW	USB device enable and the internal pull-up resistor control bit in USB device mode, if it is 1, enable the USB device transmission and enable the internal pull-up resistor.	0
[5:4]	MASK_UC_SYS_CTRL	RW	See the table below to configure the USB system.	00b
3	RB_UC_INT_BUSY	RW	Automatic pause enable bit before USB transfer completion interrupt flag is not reset. 1: Automatic pause before the interrupt flag UIF_TRANSFER is reset. In the device mode, the busy NAK is automatically answered; in the host mode, the subsequent transmission is automatically suspended; 0: No pause.	0
2	RB_UC_RESET_SIE	RW	USB protocol processor software reset control bit: 1: Force reset USB protocol processor (SIE). Need software to reset; 0: No reset.	1
1	RB_UC_CLR_ALL	RW	Reset USB's FIFO and interrupt flag: 1: Force emptying and clearing; 0: No clearing.	1
0	RB_UC_DMA_EN	RW	USB's DMA and DMA interrupt control bit: 1: Enable DMA feature and DMA interrupt; 0: Turn off DMA.	0

The USB system control combination consists of RB_UC_HOST_MODE and MASK_UC_SYS_CTRL:

RB_UC_HOST_MODE	MASK_UC_SYS_CTRL	Description of USB system control
0	00	Disable the USB device function and turn off the internal pull-up resistor.
0	01	Enable the USB device function, turn off the internal pull-up resistor, and add an external pull-up.
0	1x	Enable the USB device function and enable the internal 1.5K pull-up resistor. This pull-up resistor takes precedence over the pull-down resistor and can also be used in GPIO mode.
1	00	USB host mode, in normal working status.

1	01	USB host mode, force DP/DM to output SE0 status.
1	10	USB host mode, force DP/DM to output J status.
1	11	USB host mode, force DP/DM to output K status/wake up.

USB Interrupt Enable Register (R8_USB_INT_EN)

Bit	Name	Access	Description	Reset value
7	RB_UIE_DEV_SOF	RW	In USB device mode, receive SOF packet interrupt: 1: Enable interrupt; 0: Disable interrupt.	0
6	RB_UIE_DEV_NAK	RW	USB device mode, receive NAK interrupt: 1: Enable interrupt; 0: Disable interrupt.	0
5	Reserved	RO	Reserved	0
4	RB_UIE_FIFO_OV	RW	FIFO overflow interrupt: 1: Enable interrupt; 0: Disable interrupt.	0
3	RB_UIE_HST_SOF	RW	In USB host mode, SOF timing interrupt: 1: Enable interrupt; 0: Disable interrupt.	0
2	RB_UIE_SUSPEND	RW	USB bus suspend or wake event interrupt: 1: Enable interrupt; 0: Disable interrupt.	0
1	RB_UIE_TRANSFER	RW	USB transfer completion interrupt: 1: Enable interrupt; 0: Disable interrupt.	0
0	RB_UIE_DETECT	RW	In USB host mode, USB device connection or disconnection event interrupt: 1: Enable interrupt; 0: Disable interrupt.	0
	RB_UIE_BUS_RST	RW	In USB device mode, USB bus reset event interrupt: 1: Enable interrupt; 0: Disable interrupt.	0

USB Device Address Register (R8_USB_DEV_AD)

Bit	Name	Access	Description	Reset value
7	RB_UDA_GP_BIT	RW	USB universal flag bit, user-defined.	0
[6:0]	MASK_USB_ADDR	RW	Host mode: The address of USB device currently operating; Device mode: The USB's own address.	0000000b

USB Miscellaneous Status Register (R8_USB_MIS_ST)

Bit	Name	Access	Description	Reset value
7	RB_UMS_SOF_PRES	RO	The SOF packet indication status bit in the USB host mode: 1: The SOF packet will be sent. If there are other USB data packets, it will be automatically delayed; 0: No SOF packet is sent.	X
6	RB_UMS_SOF_ACT	RO	SOF packet transmission status bit in the USB host mode: 1: SOF packet is being sent; 0: Transmission is complete or idle.	X
5	RB_UMS_SIE_FREE	RO	Idle status bit of the USB protocol processor: 1: Protocol is idle; 0: Busy. USB transfer is in progress.	1
4	RB_UMS_R_FIFO_RDY	RO	USB received FIFO data ready status bit: 1: Received FIFO is not empty; 0: Received FIFO is empty.	0

3	RB_UMS_BUS_RESET	RO	USB bus reset status bit: 1: The current USB bus is in the reset state; 0: The current USB bus is in the non-reset state.	X
2	RB_UMS_SUSPEND	RO	USB suspend status bit: 1: The USB bus is in a suspended state and there is no USB activity for a while; 0: The USB bus is in a non-suspended state.	0
1	RB_UMS_DM_LEVEL	RO	In USB host mode, the device just connected to the USB port is in the level state of the DM pins and is used to determine the speed: 1: High level / low speed; 0: Low level / full speed.	0
0	RB_UMS_DEV_ATTACH	RO	USB device connection status bit for ports in USB host mode: 1: The port is connected to a USB device; 0: The port has no USB device connection.	0

USB Interrupt Flag Register (R8_USB_INT_FG)

Bit	Name	Access	Description	Reset value
7	RB_U_IS_NAK	RO	In USB device mode, the NAK response status bit: 1: Respond to NAK during the current USB transfer process; 0: No NAK response.	0
6	RB_U_TOG_OK	RO	Current USB transfer DATA0/1 sync flag match status bit: 1: Sync; 0: Not synchronized.	0
5	RB_U_SIE_FREE	RO	USB protocol processor idle status bit: 1: USB is idle; 0: Busy, USB transfer is in progress.	1
4	RB_UIF_FIFO_OV	RW	USB FIFO overflow interrupt flag bit. Write 1 to reset: 1: FIFO overflow trigger; 0: No event.	0
3	RB_UIF_HST_SOF	RW	SOF timer interrupt flag bit in USB host mode. Write 1 to reset: 1: SOF packet transmission completion trigger; 0: No event.	0
2	RB_UIF_SUSPEND	RW	USB bus suspend or wake event interrupt flag bit. Write 1 to reset: 1: USB suspend event or wake-up event trigger; 0: No event.	0
1	RB_UIF_TRANSFER	RW	USB transfer completion interrupt flag bit. Write 1 to reset: 1: A USB transfer completion trigger; 0: No event.	0
0	RB_UIF_DETECT	RW	USB device connection or disconnection event interrupt flag bit in the USB host mode. Write 1 to reset: 1: Detected USB device connection or disconnection trigger; 0: No event.	0
	RB_UIF_BUS_RST	RW	USB bus reset event interrupt flag bit in USB device mode. Write 1 to reset: 1: USB bus reset event trigger; 0: No event.	0

USB Interrupt Status Register (R8_USB_INT_ST)

Bit	Name	Access	Description	Reset value
7	RB_UIS_IS_NAK	RO	In USB device mode, the NAK response status bit is the same as RB_U_IS_NAK: 1: Respond to NAK during current USB transfer; 0: No NAK response.	0
6	RB_UIS_TOG_OK	RO	The current USB transfer DATA0/1 sync flag matches the status bit, the same as RB_U_TOG_OK: 1: Sync; 0: Not synchronized.	0
[5:4]	MASK_UIS_TOKEN	RO	In the device mode, the token PID ID of the current USB transfer transaction.	XXb
[3:0]	MASK_UIS_ENDP	RO	In the device mode, the endpoint number of the current USB transfer transaction.	XXXXb
	MASK_UIS_H_RES	RO	The response PID ID of the current USB transfer transaction in the host mode: 0000 indicates that the device has no response or timeout; other values indicate the response to PID.	XXXXb

MASK_UIS_TOKEN is used for identifying the token PID of the current USB transfer transaction in USB device mode: 00 for OUT packets; 01 for SOF packets; 10 for IN packets; 11 for SETUP packets.

MASK_UIS_H_RES is only valid in the host mode. In the host mode, if the host sends an OUT/SETUP token packet, the PID is the handshake packet ACK/NAK/STALL, or the device has no response/timeout. If the host sends an IN token packet, the PID is the PID of the data packet (DATA0/DATA1) or the handshake packet PID.

USB Receive Length Register (R8_USB_RX_LEN)

Bit	Name	Access	Description	Reset value
[7:0]	R8_USB_RX_LEN	RO	The number of data bytes received by the current USB endpoint.	XXh

17.2.2 Device register

In the USB device mode, a chip is provided with five sets of bidirectional endpoints: Endpoint 0, Endpoint 1, Endpoint 2, Endpoint 3 and Endpoint 4. The maximum data packet length is 64 bytes for all endpoints.

Endpoint 0 is the default endpoint and supports control transfers. One 64-byte data buffer zone is shared by transmission and reception. Endpoint 1, Endpoint 2 and Endpoint 3 each include a transmit endpoint IN and a receive endpoint OUT. Both transmission and reception have an independent 64-byte or dual 64-byte data buffer zone that supports bulk transfer, interrupt transfer, and real-time/synchronization transfer.

Endpoint 4 includes a transmit endpoint IN and a receive endpoint OUT. Both transmission and reception are provided with an independent 64-byte data buffer zone that supports bulk transfers, interrupt transfers, and real-time/synchronous transfers.

Each set of endpoints has a control register R8_UEPn_CTRL and a transmit length register R8_UEPn_T_LEN (n=0/1/2/3/4) that is used to set the synchronization trigger bit of the endpoint, the response to the OUT transaction and the IN transaction, the length of transmit data, etc.

Whether to enable the USB bus pull-up resistor which is necessary for a USB device can be set by software at any time. When RB_UC_DEV_PU_EN in the USB control register R8_USB_CTRL is set to 1, the controller is set according to the speed of RB_UD_LOW_SPEED. Internally, pull-up resistors are connected with the DP/DM pins of the USB bus, and the function of USB device is enabled.

When a USB bus reset, a USB bus suspend or a wake-up event is detected, or when USB successfully finishes processing data transmission or data reception, the USB protocol processor will set the corresponding interrupt flag. If an interrupt is enabled, the corresponding interrupt request will also be generated. The application can be used to directly query or analyze the interrupt flag register R8_USB_INT_FG in the USB interrupt service program. Corresponding processing is made according to RB_UIF_BUS_RST and RB_UIF_SUSPEND; if RB_UIF_TRANSFER is valid, it is necessary to continue analyzing the USB interrupt status register R8_USB_INT_ST and correspondingly process according to the current endpoint number of MASK_UIS_ENDP and the current transaction token PID ID of MASK_UIS_TOKEN. If the synchronization trigger bit

RB_UEP_R_TOG of the OUT transaction of each endpoint is set in advance, RB_U_TOG_OK or RB_UIS_TOG_OK can be used to judge whether the synchronization trigger bit of the currently received data packet matches the synchronization trigger bit of the endpoint. If the data is synchronized, the data is valid; if not, the data should be discarded. After each processing of the USB transmission or reception interrupt, the synchronization trigger bit of the corresponding endpoint should be correctly modified to detect whether the next transmitted data packet or the next received data packet is synchronous. In addition, RB_UEP_AUTO_TOG can be set to implement the automatically flip of the corresponding synchronization trigger bits after the transmission is successful or the reception is successful.

The data that each endpoint is ready to send is in its own buffer zone. The length of the data to be sent is independently set in R8_UEPn_T_LEN; the data received by each endpoint is in its own buffer zone, but the length of the received data is in the USB Receive Length Register R8_USB_RX_LEN, which can be distinguished according to the current endpoint number when the USB receives an interrupt.

Table 17-2 List of USB device related registers
(those marked as gray are reset and controlled by RB_UC_RESET_SIE)

Name	Access address	Description	Reset value
R8_UDEV_CTRL	0x40008001	USB Device Physical Port Control Register	0xX0
R8_UEP4_1_MOD	0x4000800c	Endpoint 1/4 Mode Control Register	0x00
R8_UEP2_3_MOD	0x4000800d	Endpoint 2/3 Mode Control Register	0x00
R16_UEP0_DMA	0x40008010	Endpoint 0 Buffer Zone Start Address	0xXXXX
R16_UEP1_DMA	0x40008014	Endpoint 1 Buffer Zone Start Address	0xXXXX
R16_UEP2_DMA	0x40008018	Endpoint 2 Buffer Zone Start Address	0xXXXX
R16_UEP3_DMA	0x4000801c	Endpoint 3 Buffer Zone Start Address	0xXXXX
R8_UEP0_T_LEN	0x40008020	Endpoint 0 Transmit Length Register	0xXX
R8_UEP0_CTRL	0x40008022	Endpoint 0 Control Register	0x00
R8_UEP1_T_LEN	0x40008024	Endpoint 1 Transmit Length Register	0xXX
R8_UEP1_CTRL	0x40008026	Endpoint 1 Control Register	0x00
R8_UEP2_T_LEN	0x40008028	Endpoint 2 Transmit Length Register	0xXX
R8_UEP2_CTRL	0x4000802a	Endpoint 2 Control Register	0x00
R8_UEP3_T_LEN	0x4000802c	Endpoint 3 Transmit Length Register	0xXX
R8_UEP3_CTRL	0x4000802e	Endpoint 3 Control Register	0x00
R8_UEP4_T_LEN	0x40008030	Endpoint 4 Transmit Length Register	0xXX
R8_UEP4_CTRL	0x40008032	Endpoint 4 Control Register	0x00

USB Device Physical Port Control Register (R8_UDEV_CTRL)

Bit	Name	Access	Description	Reset value
7	RB_UD_PD_DIS	RW	Internal pull-down resistor control bit of USB device port UD+/UD- pins: 1: Disable internal pull-down; 0: Enable internal pull-down. It can be used to provide pull-down resistors in GPIO mode.	1
6	Reserved	RO	Reserved	0
5	RB_UD_DP_PIN	RO	Current UD+ pin status: 1: High level; 0: Low level.	X

4	RB_UD_DM_PIN	RO	Current UD-pin status: 1: High level; 0: Low level.	X
3	Reserved	RO	Reserved	0
2	RB_UD_LOW_SPEED	RW	USB device physical port low speed mode enable bit: 1: Select 1.5Mbps low speed mode; 0: Select 12Mbps full speed mode.	0
1	RB_UD_GP_BIT	RW	USB device mode universal flag bit, user-defined.	0
0	RB_UD_PORT_EN	RW	USB device physical port enable bit: 1: Enable physical port; 0: Disable physical port.	0

Endpoint 1/4 Mode Control Register (R8_UEP4_1_MOD)

Bit	Name	Access	Description	Reset value
7	RB_UEP1_RX_EN	RW	1: Enable Endpoint 1 reception (OUT); 0: Disable Endpoint 1 reception.	0
6	RB_UEP1_TX_EN	RW	1: Enable Endpoint 1 transmission (IN); 0: Disable Endpoint 1 transmission.	0
5	Reserved	RO	Reserved	0
4	RB_UEP1_BUF_MOD	RW	Endpoint 1 data buffer zone mode control bit.	0
3	RB_UEP4_RX_EN	RW	1: Enable Endpoint 4 reception (OUT); 0: Disable Endpoint 4 reception.	0
2	RB_UEP4_TX_EN	RW	1: Enable Endpoint 4 transmission (IN); 0: Disable Endpoint 4 transmission.	0
[1:0]	Reserved	RO	Reserved	0

The combination of bUEP4_RX_EN and bUEP4_TX_EN configure the data buffer modes of USB Endpoint 0 and Endpoint 4. Please refer to the following table:

Table 17-3 Buffer zone modes of Endpoint 0 and Endpoint 4

bUEP4_RX_EN	bUEP4_TX_EN	Description: Arranged from low to high with UEPO_DMA as the start address
0	0	Endpoint 0 single 64-byte transceiver shared buffer zone (IN and OUT).
1	0	Endpoint 0 single 64-byte transceiver shared buffer zone: Endpoint 4 single 64-byte reception buffer zone (OUT).
0	1	Endpoint 0 single 64-byte transceiver shared buffer zone: Endpoint 4 single 64-byte transmit buffer zone (IN).
1	1	Endpoint 0 single 64-byte transceiver shared buffer zone: Endpoint 4 single 64-byte reception buffer zone (OUT); Endpoint 4 single 64-byte reception buffer zone (IN). A total of 192 bytes are arranged as follows: UEPO_DMA+0 Address: 64-byte start address of Endpoint 0 Transceiver Shared Buffer Zone; UEPO_DMA+64 address: 64-byte start address of Endpoint 4 Receive Buffer Zone; UEPO_DMA+128 address: 64-byte start address of Endpoint 4 Transmit Buffer Zone.

Endpoint 2/3 Mode Control Register (R8 UEP2_3_MOD)

Bit	Name	Access	Description	Reset value
7	RB_UEP3_RX_EN	RW	1: Enable Endpoint 3 reception (OUT); 0: Disable Endpoint 3 reception.	0
6	RB_UEP3_TX_EN	RW	1: Enable Endpoint 3 transmission (IN); 0: Disable Endpoint 3 transmission.	0
5	Reserved	RO	Reserved	0
4	RB_UEP3_BUF_MOD	RW	Endpoint 3 data buffer zone mode control bit.	0
3	RB_UEP2_RX_EN	RW	1: Enable Endpoint 2 reception (OUT); 0: Disable Endpoint 2 reception.	0
2	RB_UEP2_TX_EN	RW	1: Enable Endpoint 2 transmission (IN); 0: Disable Endpoint 2 transmission.	0
1	Reserved	RO	Reserved	0
0	RB_UEP2_BUF_MOD	RW	Endpoint 2 data buffer zone mode control bit.	0

The data buffer zone modes of USB Endpoint 1, Endpoint 2 and Endpoint 3 are respectively configured by the combination of RB_UEPn_RX_EN and RB_UEPn_TX_EN and RB_UEPn_BUF_MOD (n=1/2/3). For details, please refer to the following table. Specifically, in the mode of dual 64-byte buffer zone, the first 64-byte buffer zone is selected according to RB_UEP_*_TOG=0 at time of USB data transmission, and the last 64-byte buffer zone is selected according to RB_UEP_*_TOG=1. RB_UEP_AUTO_TOG=1 can be set to be automatic switching.

Table 17-4 Buffer zone modes of Endpoint n (n=1/2/3)

RB_UEPn_RX_EN	RB_UEPn_TX_EN	RB_UEPn_BUF_MOD	Description: Arranged from low to high with R16_UEPn_DMA as the start address
0	0	X	The endpoint is disabled and the R16_UEPn_DMA buffer zone is not used.
1	0	0	Single 64-byte reception buffer zone (OUT).
1	0	1	Dual 64-byte reception buffer zone (OUT), selected by RB_UEP_R_TOG.
0	1	0	Single 64-byte transmission buffer zone (IN).
0	1	1	Dual 64-byte transmission buffer zone (IN), selected by RB_UEP_T_TOG.
1	1	0	Single 64-byte reception buffer zone (OUT), single 64-byte transmission buffer zone (IN).
1	1	1	Dual 64-byte reception buffer zone (OUT), selected by RB_UEP_R_TOG, Dual 64-byte transmit buffer zone (IN), selected by RB_UEP_T_TOG. All 256 bytes are arranged as follows: UEPn_DMA+0 address: the endpoint reception address when RB_UEP_R_TOG=0; UEPn_DMA+64 address: the endpoint reception address when RB_UEP_R_TOG=1; UEPn_DMA+128 address: the endpoint transmission address when RB_UEP_T_TOG=0; UEPn_DMA+192 address: the endpoint transmission address when RB_UEP_T_TOG=1.

Endpoint n Buffer Zone Start Address (R16_UEPn_DMA) (n=0/1/2/3)

Bit	Name	Access	Description	Reset value
[15:0]	R16_UEPn_DMA	RW	Start Address of Endpoint n Buffer Zone The low 15 bits are valid and the address must be 4 bytes aligned.	XXXXh

Note: The length of the buffer zone that receives the data \geq min (the maximum length of data packet that can be received + 2 bytes, 64 bytes).

Endpoint n Transmit Length Register (R8_UEPn_T_LEN) (n=0/1/2/3/4)

Bit	Name	Access	Description	Reset value
[7:0]	R8_UEPn_T_LEN	RW	Set the number of data bytes that the USB Endpoint n is ready to send.	XXh

Endpoint n Control Register (R8_UEPn_CTRL) (n=0/1/2/3/4)

Bit	Name	Access	Description	Reset value
7	RB_UEP_R_TOG	RW	The desired trigger bit of the receiver of USB Endpoint n (processing the OUT transaction): 1: Expect DATA1; 0: Expect DATA0.	0
6	RB_UEP_T_TOG	RW	The prepared sync trigger bit of the transmitter of USB Endpoint n (processing the IN transaction): 1: Send DATA1; 0: Send DATA0.	0
5	Reserved	RO	Reserved	0
4	RB_UEP_AUTO_TOG	RW	Synchronous trigger bit auto flip enable control bit: 1: The corresponding synchronous trigger bit is automatically flipped after the data is sent or received successfully; 0: No automatic flip. Manual switch is allowed. Only support Endpoint 1/2/3.	0
[3:2]	MASK_UEP_R_RES	RW	The response control of the receiver of Endpoint n to the OUT transaction: 00: Answer to ACK; 01: Timeout/no response, used for real-time/synchronous transmission of endpoints other than Endpoint 0; 10: Answer to NAK or busy; 11: Answer to STALL or error.	00b
[1:0]	MASK_UEP_T_RES	RW	The response control of the transmitter of Endpoint n to the IN transaction: 00: DATA0/DATA1 data is ready and expect ACK; 01: Answer to DATA0/DATA1, expect no response, and used for real-time/synchronous transmission of endpoints other than Endpoint 0; 10: Answer to NAK or busy; 11: Answer to STALL or error.	00b

17.2.3 Host register

In the USB host mode, a chip is provided with a set of bidirectional host endpoints, including a transmit endpoint OUT and a receive endpoint IN. The maximum length of the data packet is 64 bytes. It supports control transfers, interrupt transfers, bulk transfers, and real-time/synchronous transfers.

Each USB transaction initiated by the host endpoint always sets the RB_UIF_TRANSFER interrupt flag

automatically after processing. The application can directly query or query and analyze the interrupt flag register R8_USB_INT_FG in the USB interrupt service program, and perform corresponding processing according to each interrupt flag; if RB_UIF_TRANSFER is valid, it is needed to continue analyzing the USB interrupt status register R8_USB_INT_ST and perform corresponding processing according to the response PID identification MASK_UIS_H_RES of the current USB transfer transaction.

If the synchronization trigger bit RB_UH_R_TOG of the IN transaction of the host receiving endpoint is set in advance, whether the synchronization trigger bit of the currently received data packet matches the synchronization trigger bit of the host receiving endpoint can be judged by RB_U_TOG_OK or RB_UIS_TOG_OK. If the data is synchronized, the data is valid; if not, the data should be discarded. After each processing of USB transmission or reception interrupt, the synchronization trigger bit of the corresponding host endpoint should be correctly modified to synchronize the next transmitted data packet and detect whether the next received data packet is synchronized. In addition, the setting of RB_UH_T_AUTO_TOG and RB_UH_R_AUTO_TOG can automatically flip the corresponding synchronization trigger bit after successful transmission or successful reception.

The USB host token setting register R8_UH_EP_PID is used to set the endpoint number of the target device being operated and the token PID packet identifier of this USB transfer transaction. The data corresponding to the SETUP token and the OUT token is provided by the host transmit endpoint. The data to be sent is in the R16_UH_TX_DMA buffer zone, and the length of the data to be sent is set in R16_UH_TX_LEN; the data corresponding to the IN token is returned to the host receive endpoint by the target device. The received data is stored in the R16_UH_RX_DMA buffer zone. The length of the received data is stored in R8_USB_RX_LEN.

Table 17-5 List of registers related to USB hosts
(Those marked as gray are reset and controlled by RB_UC_RESET_SIE)

Name	Access address	Description	Reset value
R8_UHOST_CTRL	0x40008001	USB Host Physical Port Control Register	0xX0
R8_UH_EP_MOD	0x4000800d	USB Host Endpoint Mode Control Register	0x00
R16_UH_RX_DMA	0x40008018	USB Host Receive Buffer Zone Start Address	0xXXXX
R16_UH_TX_DMA	0x4000801c	USB Host Transmit Buffer Zone Start Address	0xXXXX
R8_UH_SETUP	0x40008026	USB Host Auxiliary Setting Register	0x00
R8_UH_EP_PID	0x40008028	USB Host Token Setting Register	0x00
R8_UH_RX_CTRL	0x4000802a	USB Host Receive Endpoint Control Register	0x00
R8_UH_TX_LEN	0x4000802c	USB Host Transmit Length Register	0xXX
R8_UH_TX_CTRL	0x4000802e	USB Host Transmit Endpoint Control Register	0x00

USB Host Physical Port Control Register (R8_UHOST_CTRL)

Bit	Name	Access	Description	Reset value
7	RB_UH_PD_DIS	RW	Internal pull-down resistor control bit of USB host port UD+/UD- pins: 1: Disable internal pull-down; 0: Enable internal pull-down. Can be used to provide pull-down resistors in the GPIO mode.	1
6	Reserved	RO	Reserved	0
5	RB_UH_DP_PIN	RO	Current UD+ pin status: 1: High level; 0: Low level.	X
4	RB_UH_DM_PIN	RO	Current UD- pin status: 1: High level; 0: Low level.	X
3	Reserved	RO	Reserved	0
2	RB_UH_LOW_SPEED	RW	USB host port low speed mode enable bit: 1: Select 1.5Mbps low speed mode; 0: Select 12Mbps full speed mode.	0

1	RB_UH_BUS_RESET	RW	USB host mode bus reset control bit: 1: Force to output USB bus reset; 0: End output.	0
0	RB_UH_PORT_EN	RW	USB host port enable bit: 1: Enable host port; 0: Disable host port. This bit is automatically reset to zero when the USB device is disconnected.	0

USB Host Endpoint Mode Control Register (R8_UH_EP_MOD)

Bit	Name	Access	Description	Reset value
7	Reserved	RO	Reserved	0
6	RB_UH_EP_TX_EN	RW	Host transmit endpoint transmission (SETUP/OUT) enable bit: 1: Enable endpoint transmission; 0: Disable endpoint transmission.	0
5	Reserved	RO	Reserved	0
4	RB_UH_EP_TBUF_MOD	RW	The mode of the host transmit endpoint transmitting data to the buffer zone control bit.	0
3	RB_UH_EP_RX_EN	RW	Host receive endpoint reception (IN) enable bit: 1: Enable endpoint reception; 0: Disable endpoint reception.	0
[2:1]	Reserved	RO	Reserved	00b
0	RB_UH_EP_RBUF_MOD	RW	The mode of the host receive endpoint receiving data to the buffer zone control bit.	0

The mode of the host transmit endpoint data buffer zone is controlled by the combination of RB_UH_EP_TX_EN and RB_UH_EP_TBUF_MOD. Please refer to the following table.

Table 17-6 Host transmit buffer zone mode

RB_UH_EP_TX_EN	RB_UH_EP_TBUF_MOD	Description: R16_UH_TX_DMA as the start address
0	X	The endpoint is disabled and the R16_UH_TX_DMA buffer zone is not used.
1	0	Single 64-byte transmit buffer zone (SETUP/OUT).
1	1	Dual 64-byte transmit buffer zone, selected by RB_UH_T_TOG: When RB_UH_T_TOG=0, select the first 64-byte buffer zone; When RB_UH_T_TOG=1, select the last 64-byte buffer zone.

The mode of the host receive endpoint data buffer zone is controlled by the combination of RB_UH_EP_RX_EN and RB_UH_EP_RBUF_MOD. Please refer to the following table.

Table 17-7 Host receive buffer zone mode

RB_UH_EP_RX_EN	RB_UH_EP_RBUF_MOD	Structure description: R16_UH_RX_DMA as the start address
0	X	The endpoint is disabled and the R16_UH_RX_DMA buffer zone is not used.
1	0	Single 64-byte receive buffer zone (IN).

1	1	Dual 64-byte transmit buffer zone, selected by RB_UH_R_TOG: When RB_UH_R_TOG=0, select the first 64-byte buffer zone; When RB_UH_R_TOG=1, select the last 64-byte buffer zone.
---	---	--

USB Host Receive Buffer Zone Start Address (R16_UH_RX_DMA)

Bit	Name	Access	Description	Reset value
[15:0]	R16_UH_RX_DMA	RW	Start address of the host endpoint data receive buffer zone. The low 15 bits are valid and the address must be 4 bytes aligned.	XXXXb

USB Host Transmit Buffer Zone Start Address (R16_UH_TX_DMA)

Bit	Name	Access	Description	Reset value
[15:0]	R16_UH_TX_DMA	RW	Start address of the host endpoint data transmit buffer zone. The low 15 bits are valid and the address must be 4 bytes aligned.	XXXXb

USB Host Auxiliary Setting Register (R8_UH_SETUP)

Bit	Name	Access	Description	Reset value
7	RB_UH_PRE_PID_EN	RW	Low speed preamble packet PRE PID enable bit: 1: Enable to communicate with a low-speed USB device via an external HUB. 0: Disable the low-speed preamble packet.	0
6	RB_UH_SOF_EN	RW	Automatically generate SOF packet enable bit: 1: The host automatically generates a SOF packet: 0: Not generated automatically, but can be generated manually.	0
[5:0]	Reserved	RO	Reserved	000000b

USB Host Token Setting Register (R8_UH_EP_PID)

Bit	Name	Access	Description	Reset value
[7:4]	MASK_UH_TOKEN	RW	Set the token PID packet ID for this USB transfer transaction.	0000b
[3:0]	MASK_UH_ENDP	RW	Set the endpoint number of the target device that is being operated this time.	0000b

USB Host Receive Endpoint Control Register (R8_UH_RX_CTRL)

Bit	Name	Access	Description	Reset value
7	RB_UH_R_TOG	RW	The expected sync trigger bit for the USB host receiver (handling the IN transaction): 1: Expected DATA1; 0: Expected DATA0.	0
[6:5]	Reserved	RO	Reserved	00b

4	RB_UH_R_AUTO_TOG	RW	Synchronous trigger bit auto flip enable control bit: 1: After data is successfully received, the corresponding expected sync trigger bit (RB_UH_R_TOG) is automatically flipped; 0: No automatic flip. Manual switch is allowed.	0
3	Reserved	RO	Reserved	0
2	RB_UH_R_RES	RW	Host receiver respond control bit to IN transaction: 1: No response, used for real-time/synchronous transfer of endpoints other than Endpoint 0; 0: Answer to ACK.	0
[1:0]	Reserved	RO	Reserved	00b

USB Host Transmit Length Register (R8_UH_TX_LEN)

Bit	Name	Access	Description	Reset value
[7:0]	R8_UH_TX_LEN	RW	Set the number of data bytes that the USB host transmit endpoint is ready to send.	XXh

USB Host Transmit Endpoint Control Register (R8_UH_TX_CTRL)

Bit	Name	Access	Description	Reset value
7	Reserved	RO	Reserved	0
6	RB_UH_T_TOG	RW	The sync trigger bit prepared by the USB host transmitter (processing SETUP/OUT transaction): 1: indicates that DATA1 is sent; 0: indicates that DATA0 is sent.	0
5	Reserved	RO	Reserved	0
4	RB_UH_T_AUTO_TOG	RW	Synchronous trigger bit auto flip enable control bit: 1: After the data is sent successfully, the corresponding synchronization trigger bit (RB_UH_T_TOG) is automatically flipped; 0: No automatic flip. Manual switch is allowed.	0
[3:1]	Reserved	RO	Reserved	000b
0	RB_UH_T_RES	RW	USB host transmitter response control bit to SETUP/OUT transaction: 1: Expect no response, used for real-time/synchronous transfers of endpoints other than endpoint 0; 0: Expect to answer to ACK.	0

Chapter 18 Ethernet Controller (ETH)

18.1 Ethernet controller introduction

A chip is integrated with the Ethernet controller MAC, PHY and DMA and is compatible with the IEEE802.3 protocol. The internal DMA transfers data and receives data to the system RAM. The PHY physical layer is a 10 Mbit/s Ethernet transceiver that provides a portion of the network PHY registers to set the performance of transmission and reception.

The underlying operations of the network mainly provide application support with the subroutine library. The registers are not described in detail. Main features are:

- Support full-duplex and half-duplex.
- Support the settings of short packet filling.
- Support CRC setting and filling.
- Support jumbo frame reception.
- Support the transmission and setting of pause frames.
- Support Auto-Negotiation mechanism.
- Support DMA for transmitting and receiving data.
- The PHY transceiver is compatible with 10BASE-T, and the sending module supports the energy saving mode.
- Built-in 50ohm transmission impedance matching resistor. External connection is optional.
- Provide a globally unique MAC address assigned by the IEEE.

18.2 Register description

Table 18-1 List of registers related to Ethernet controller

Name	Offset address	Description	Reset value
R8_ETH_EIE	0x40009003	Interrupt Enable Register	0x00
R8_ETH_EIR	0x40009004	Interrupt Flag Register	0x00
R8_ETH_ESTAT	0x40009005	Status Register	0x00
R8_ETH_ECON2	0x40009006	PHY Analog Parameter Setting Register	0x06
R8_ETH_ECON1	0x40009007	Transceiver Control Register	0x00
R32_ETH_TX	0x40009008	Transmit DMA Control Register	0xFFFFFFFF
R16_ETH_ETXST	0x40009008	Transmit DMA Buffer Start Address Register	0XXXX
R16_ETH_ETXLN	0x4000900A	Transmit Length Register	0XXXX
R32_ETH_RX	0x4000900C	Receive DMA Control Register	0x00000000
R16_ETH_ERXST	0x4000900C	Receive DMA Buffer Start Address Register	0x0000
R16_ETH_ERXLN	0x4000900E	Receive Length Register	0x0000
R8_ETH_MACON1	0x40009019	Mac Layer Flow Control Register	0x00
R8_ETH_MACON2	0x4000901A	Mac Layer Packet Control Register	0x00
R8_ETH_MABBIPG	0x4000901B	Minimum Inter-packet Interval Register	0x10
R32_ETH_TIM	0x4000901C	Flow Control Pause Frame Time Register	0xFFFFFFFF
R16_ETH_EPAUS	0x4000901C	Flow Control Pause Frame Time Register	0XXXX
R16_ETH_MAMXFL	0x4000901E	Maximum Receive Packet Length Register	0x0000
R16_ETH_MIRD	0x40009020	MII Read Data Register	0x1100
R32_ETH_MIWR	0x40009024	MII Write Register	0x00000000
R8_ETH_MIREGADR	0x40009024	MII Address Register	0x00
R8_ETH_MISTAT	0x40009025	MII Status Register	0x00

R16_ETH_MIWR	0x40009026	MII Write Data Register	0x0000
R32_ETH_MAADRL	0x40009028	MAC Address Low Byte Register	0xFFFFFFFF
R16_ETH_MAADRH	0x4000902C	MAC Address High Byte Register	0XXXX

Interrupt Enable Register (R8_ETH_EIE)

Bit	Name	Access	Description	Reset value
7	RB_ETH_EIE_INTIE	RW	Ethernet interrupt enable: 0: Turn off interrupt; 1: Turn on interrupt.	0
6	RB_ETH_EIE_RXIE	RW	Reception completion interrupt enable: 0: Turn off interrupt; 1: Turn on interrupt.	0
5	Reserved	RO	Reserved	0
4	RB_ETH_EIE_LINKIE	RW	Link change interrupt enable: 0: Turn off interrupt; 1: Turn on interrupt.	0
3	RB_ETH_EIE_TXIE	RW	Transmission completion interrupt enable: 0: Turn off interrupt; 1: Turn on interrupt.	0
2	RB_ETH_EIE_R_EN50	RW	Built-in 50 ohm impedance matching resistor enable: 0: On-chip resistor disconnected; 1: On-chip resistor connection.	0
1	RB_ETH_EIE_TXERIE	RW	Transmission error interrupt enable: 0: Turn off interrupt; 1: Turn on interrupt.	0
0	RB_ETH_EIE_RXERIE	RW	Reception error interrupt enable: 0: Turn off interrupt; 1: Turn on interrupt.	0

Interrupt Flag Register (R8_ETH_EIR)

Bit	Name	Access	Description	Reset value
7	Reserved	RO	Reserved	0
6	RB_ETH_EIR_RXIF	RW1	Reception completion flag.	0
5	Reserved	RO	Reserved	0
4	RB_ETH_EIR_LINKIF	RW1	Link change flag.	0
3	RB_ETH_EIR_TXIF	RW1	Transmission completion flag.	0
2	Reserved	RO	Reserved	0
1	RB_ETH_EIR_TXERIF	RW1	Transmission error flag.	0
0	RB_ETH_EIR_RXERIF	RW1	Reception error flag.	0

Status Register (R8_ETH_ESTAT)

Bit	Name	Access	Description	Reset value
7	RB_ETH_ESTAT_INT	RW1	Interrupted.	0
6	RB_ETH_ESTAT_BUFER	RW1	Buffer error.	0
5	RB_ETH_ESTAT_RXCRCER	RO	Receive CRC error.	0
4	RB_ETH_ESTAT_RXNIBBLE	RO	Receive nibble error.	0
3	RB_ETH_ESTAT_RXMORE	RO	Reception exceeds the set maximum packet.	0
2	RB_ETH_ESTAT_RXBUSY	RO	Reception is in progress.	0
1	RB_ETH_ESTAT_TXABRT	RO	Transmission is interrupted by the MCU.	0
0	Reserved	RO	Reserved	0

PHY Analog Parameter Setting Register (R8_ETH_ECON2)

Bit	Name	Access	Description	Reset value
[7:4]	Reserved	RO	Reserved	0000b
[3:1]	RB_ETH_ECON2_RX RB_ETH_ECON2_MUST	RW	Reserved. 011 must be written.	011b
0	RB_ETH_ECON2_TX	RW	Transmitting end energy-saving drive control: 0: Rated drive; 1: Energy-saving drive.	0

Transceiver Control Register (R8_ETH_ECON1)

Bit	Name	Access	Description	Reset value
7	RB_ETH_ECON1_TXRST	RW	Transmission module reset: 0: No reset; 1: Reset the transmission module.	0
6	RB_ETH_ECON1_RXRST	RW	Reception module reset: 0: No reset; 1: Reset the reception module.	0
[5:4]	Reserved	RO	Reserved	00b
3	RB_ETH_ECON1_TXRTS	RW	Transmission starts and is automatically reset to zero after the transmission is completed: 1: Start transmission; 0: No action.	0
2	RB_ETH_ECON1_RXEN	RW	Reception enable control: 0: Turn off reception; 1: Turn on reception.	0
[1:0]	Reserved	RO	Reserved	00b

Transmit DMA Buffer Address Register (R16_ETH_ETXST)

Bit	Name	Access	Description	Reset value
[15:0]	R16_ETH_ETXST	RW	Transmit the start address of the DMA buffer zone. The low 15 bits are valid and the address must be 4 bytes aligned.	XXXXh

Transmit Length (R16_ETH_ETXLN)

Bit	Name	Access	Description	Reset value
[15:0]	R16_ETH_ETXLN	RW	The length of transmission	XXXXh

Receive DMA Buffer Address Register (R16_ETH_ERXST)

Bit	Name	Access	Description	Reset value
[15:0]	R16_ETH_ERXST	RW	Receive the start address of the DMA buffer zone. The low 15 bits are valid and the address must be 4 bytes aligned.	XXXXh

Receive Length Register (R16_ETH_ERXLN)

Bit	Name	Access	Description	Reset value
[15:0]	R16_ETH_ERXLN	RO	The length of reception	0000h

Mac Layer Flow Control Register (R8 ETH_MACON1)

Bit	Name	Access	Description	Reset value
[7:6]	Reserved	RO	Reserved	00b
[5:4]	RB_ETH_MACON1_FCEN	RW	Pause frame is set to be valid under full duplex: 00: Stop sending a pause frame; 01: Send a pause frame and then stop sending; 10: Periodically send a pause frame; 11: Send 0 timer pause frame and then stop sending.	00b
3	RB_ETH_MACON1_TXPAUS	RW	Transmit pause frame enable control: 0: No pause frame is transmitted; 1: Enable transmission.	
2	RB_ETH_MACON1_RXPAUS	RW	Receive pause frame enable: 0: No pause frame is received; 1: Enable reception.	0
1	RB_ETH_MACON1_PASSALL	RW	Control frame settings: 0: Control frames will be filtered; 1: Control frames that are not filtered will be written to the cache.	0
0	RB_ETH_MACON1_MARXEN	RW	MAC layer receive enable: 0: MAC does not receive data; 1: Enable MAC to receive.	0

Mac Layer Packet Control Register (R8 ETH_MACON2)

Bit	Name	Access	Description	Reset value
[7:5]	RB_ETH_MACON2_PADCFG	RW	Set the filling of short packets: 7: All short packets are filled with 0 to 64 bytes, and then 4 bytes of CRC; 6: Short packets are not filled; 5: It is detected that the VLAN network packet with the field of 8100h is automatically filled with 0 to 64 bytes, otherwise the short packet is filled with 60 bytes of 0 and then 4 bytes of CRC after filling; 4: Short packets are not filled; 3: All short packets are filled with 0 to 64 bytes, then 4 bytes of CRC; 2: Short packets are not filled; 1: All short packets are filled with 0 to 60 bytes, then 4 bytes of CRC; 0: Short packets are not filled.	000b
4	RB_ETH_MACON2_TXCRCEN	RW	Transmit and add CRC Control: 0: Hardware is not filled with CRC; 1: Hardware is filled with CRC.	0
3	RB_ETH_MACON2_PHDREN	RW	Special 4 bytes do not participate in the CRC check.	0
2	RB_ETH_MACON2_HFRMEN	RW	Allow receiving jumbo frames: 0: Do not allow jumbo frames to be received; 1: Allow reception.	0
1	Reserved	RO	Reserved	0
0	RB_ETH_MACON2_FULDPX	RW	Mode of Ethernet communication: 0: Half duplex; 1: Full duplex.	0

Minimum Inter-packet Interval Register (R8_ETH_MABBIPG)

Bit	Name	Access	Description	Reset value
7	Reserved	RO	Reserved	0
[6:0]	R8_ETH_MABBIPG	RW	The minimum number of bytes of inter-packet interval.	0010000b

Flow Control Pause Frame Time Register (R16_ETH_EPAUS)

Bit	Name	Access	Description	Reset value
[15:0]	R16_ETH_EPAUS	RW	Flow control pause the frame time.	XXXXh

Maximum Receive Packet Length Register (R16_ETH_MAMXFL)

Bit	Name	Access	Description	Reset value
[15:0]	R16_ETH_MAMXFL	RW	Maximum length of the reception packet.	0000h

MII Read Data Register (R16_ETH_MIRD)

Bit	Name	Access	Description	Reset value
[15:0]	R16_ETH_MIRD	RW	MII read data register.	1100h

MII Address Register (R8_ETH_MIREGADR)

Bit	Name	Access	Description	Reset value
[7:5]	Reserved	RO	Reserved	000b
[4:0]	RB_ETH_MIREGADR_MIRDL	RW	The address of PHY register	00000b

MII Status Register (R8_ETH_MISTAT)

Bit	Name	Access	Description	Reset value
[7:1]	Reserved	RO	Reserved	0000000b
0	R8_ETH_MII_STA	RO	Operation status of MII register: 1: Write MII register; 0: Read MII register.	0

MII Write Data Register (R16_ETH_MIWR)

Bit	Name	Access	Description	Reset value
[15:0]	R16_ETH_MIWR	RW	MII write data register.	0000h

MAC Address Register (R32_ETH_MAADRL, R16_ETH_MAADRH)

Bit	Name	Access	Description	Reset value
[31:0]	R32_ETH_MAADRL	RW	MAC Address Byte 1~4.	XXXXXXXXh
[15:0]	R16_ETH_MAADRH	RW	MAC Address Byte 5~6.	XXXXh

18.3 Operation guide

1. Initialize
 - (1) Configure the safety register to enter the safe mode, open the clock and power of the Ethernet network;
 - (2) Turn on the corresponding interrupt, and optionally enable the impedance matching resistor;
 - (3) Configure CRC function, MAC address;

- (4) Set the cache;
 - (5) Start receiving, and open interrupt.
2. Transmit data
 - (1) Write the data length of R16_ETH_ETXLN;
 - (2) Write the data address of R16_ETH_ETXST;
 - (3) Enable the RB_ETH_ECON1_TXRTS flag to start transmission.
 3. Receive data
 - (1) Set the reception address in advance, and enable to receive;
 - (2) Use interrupt or query the status of reception completion;
 - (3) Read the reception length of R16_ETH_ERXLN;
 - (4) Update the reception address of R16_ETH_ERXST.

The specific application should be based on the Ethernet protocol stack library and refer to the provided network application examples.

Chapter 19 Wireless Communication

19.1 Introduction

A chip is integrated with low-power 2.4-GHz wireless communication modules, including RF transceivers, baseband, link control, and antenna matching networks. Bluetooth Low Energy is supported. More than one hundred registers are provided internally to adjust parameters, control processes and states. This manual will not provide a detailed description of registers. Only some registers commonly used by the application layer are listed. The underlying operations of wireless communication mainly provide application support with the help of the subroutine library.

Main features:

- Integrate 2.4GHz RF transceiver, BaseBand and LLE link control.
- Support low-power Bluetooth (BLE), and comply with the specifications of Bluetooth Low Energy 4.2.
- Single-ended RF interface; there is no need to match external inductor and capacitor and filter networks; simplified board-level design.
- Reception sensitivity is -93dBm.
- Programmable transmission power from -20dBm to +3dBm; support dynamic adjustment.
- The wireless communication distance of the PCB onboard antenna is about 100 meters when power is transmitted at 0dBm.
- After the built-in DC-DC conversion is used, the current is more than 6mA when power is transmitted at 0dBm.
- Support AES encryption and decryption.
- Support DMA.
- Provide optimized protocol stack and application layer APIs to support networking.

19.2 LLE Module

The LLE module supports automatic transceiving mode and manual transceiving mode as well as 5 independent hardware timers. It is able to control the time point of any process of sending and receiving data.

19.2.1 Register description

Table 19-1 List of registers related to LLE module

Name	Offset address	Description	Reset value
R32_LLE_CTRL_CMD	0x4000C200	LLE command	0x00000000
R32_LLE_CTRL_CFG	0x4000C204	LLE configuration	0x00000F01
R32_LLE_STATUS	0x4000C208	LLE status	0x00000000
R32_LLE_INT_EN	0x4000C20C	LLE interrupt enable	0x00003F1F
R32_LLE_CTRL_MOD	0x4000C250	LLE mode control	0x00000011

19.2.2 Function and configuration

Initialization process:

- (1) Set R32_LLE_CTRL_MOD Register, write 58H, configure as the LLE mode, and turn on the power to enable the feature of DMA and BB module.
- (2) Set R32_LLE_CTRL_CFG Register, and configure LLE as the mode of transmit-receive data automatically or manually.
- (3) Set R32_LLE_CTRL_CMD Register and select 4 working states: transmit, receive, stop, and turn off. The details are as follows:
 - CMD_RX Use: Set the current mode to receive. In manual mode, after reception is completed, it will be reset to 0 automatically. In automatic mode, the process of cyclic transmission and reception will be repeated and can be stopped by CMD_STOP or CMD_SHUT.
 - CMD_TX Use: Set the current mode to transmit. In manual mode, after transmission is completed, it will be reset to 0 automatically. In automatic mode, the process of cyclic transmission and reception will be repeated and can be stopped by CMD_STOP or CMD_SHUT.
 - CMD_STOP Use: In the automatic transmission mode, when CMD_STOP is set to 1 during the frame interval,

the CMD_TX status will be reset and redirected to LLE_IDLE, and the software cannot directly reset the CMD_TX status. In the automatic reception mode, when CMD_STOP is set to 1 during the frame interval, the CMD_TX status will be reset and redirected to LLE_IDLE, and the software cannot directly reset the CMD_RX status.

CMD_SHUT Use: When CMD_SHUT is set, CMD_TX/CMD_RX/CMD_STOP/CMD_SHUT will all be reset and the LLE status machine will be reset.

19.3 DMA Module

A controller has 2 sets of DMA, and each set of DMA has two channels. The two channels of DMA0 are used to transmit data and receive data respectively. The two channels of DMA2 are used in the automatic mode. In the automatic transmission mode, the address of transmitting DMA and the address of receiving DMA can be configured at the same time, so that reconfiguration is not required during the frame interval.

19.3.1 Register description

Table 19-2 List of registers related to DMA module

Name	Offset address	Description	Reset value
R32_DMA0_CTRL_CFG	0x4000C008	DMA0 configuration register	0x00002000
R32_DMA2_CTRL_CFG	0x4000C00C	DMA2 configuration register	0x00002000
R32_DMA0_TX_SRC	0x4000C010	DMA0 source address Used to configure the start address of transmitting data	0x00000000
R32_DMA2_TX_SRC	0x4000C014	DMA2 source address, automatic receiving mode Used to configure the start address of transmitting data	0x00000000
R32_DMA0_RX_DST	0x4000C018	DMA0 destination address Used to configure the start address of receiving data	0x00000000
R32_DMA2_RX_DST	0x4000C01C	DMA2 destination address, automatic transmission mode Used to configure the start address of receiving data	0x00000000

19.3.2 Function and description

Operation flow of transmission:

- (1) Set R32_DMA0_TX_SRC Register and write the address of the transmitted data.
- (2) Set R32_DMA0_CTRL_CFG Register and write the length of the transmitted data.
- (3) Set IRQMASK of R32_DMA0_CTRL_CFG Register to 1.
- (4) In the automatic mode, set R32_DMA2_RX_DST Register and write the address of the received data.
- (5) In the automatic mode, set IRQMASK of R32_DMA2_CTRL_CFG Register to 1.

Operation flow of reception:

- (1) Set R32_DMA0_RX_DST Register and write the address of the received data.
- (2) Set IRQMASK of R32_DMA0_CTRL_CFG Register to 1.
- (3) In the automatic mode, set R32_DMA2_TX_SRC and write the address of the transmitted data.
- (4) In the automatic mode, set R32_DMA2_CTRL_CFG Register and write the length of the transmitted data.
- (5) In the automatic mode, set IRQMASK of R32_DMA2_CTRL_CFG Register to 1.

19.4 BB Module

19.4.1 Register description

Table 19-3 List of registers related to BB module

Name	Offset address	Description	Reset value
R32_BB_CTRL_CFG	0x4000C100	BB Configuration Register	0x000822A7

R32_BB_TXCRC_INIT	0x4000C104	Transmit CRC Initial Value Configuration Register	0x0056BC9B
R32_BB_TXACCS_ADDR	0x4000C108	Transmit Access Address Configuration Register	0x8E89BED6
R32_BB_RXCRC_INIT	0x4000C10C	Receive CRC Initial Value Configuration Register	0x0056BC9B
R32_BB_RXACCS_ADDR	0x4000C110	Receive Access Address Configuration Register	0xBE89BED6
R32_BB_CTRL_TX	0x4000C12C	Transmit Control Register	0x00010008
R32_BB_RSSI_ST	0x4000C130	BB Reception Signal Quality Status	0x00000000
R32_BB_INT_EN	0x4000C134	BB Interrupt Enable	0x00000003
R32_BB_INT_ST	0x4000C138	BB Interrupt Status	0x00000000

19.4.2 Function and description

Data whitening, transmission and reception of AA, transmission and reception of CRC initial value, and communication channels can be configured.

Configure the transmitted data:

- (1) Configure the address of the transmitted access.
- (2) Configure the initial value of the transmitted CRC.
- (3) Configure the communication channels of the transmitted data.

Configure the received data:

- (1) Configure the address of the received access.
- (2) Configure the initial value of the received CRC.
- (3) Configure the communication channel of the received data.

19.5 AES Module

19.5.1 Register description

Table 19-4 List of registers related to AES module

Name	Offset address	Description	Reset value
R32_AES_CTRL_CCMOD	0x4000C300	AES Mode Register	0x00000060
R32_AES_CCMINT_EN	0x4000C304	AES Interrupt Register	0x00000000
R32_AES_CCMVT_INIT0	0x4000C308	AES CCM Mode Initial Vector Value	0x00000000
R32_AES_CCMVT_INIT1	0x4000C30C	AES CCM Mode Initial Vector Value	0x00000000
R32_AES_PKT_CNT0	0x4000C310	AES CCM Mode Data Packet Count Value	0x00000000
R32_AES_PKT_CNT0	0x4000C314	AES CCM Mode Data Packet Count Value	0x00000000
R32_AES_DATA0	0x4000C318	AES Data Register	0x00000000
R32_AES_DATA1	0x4000C31C	AES Data Register	0x00000000
R32_AES_DATA2	0x4000C320	AES Data Register	0x00000000
R32_AES_DATA3	0x4000C324	AES Data Register	0x00000000
R32_AES_KEY0	0x4000C328	AES Encryption Key Register 0	0x00000000
R32_AES_KEY1	0x4000C32C	AES Encryption Key Register 1	0x00000000
R32_AES_KEY2	0x4000C330	AES Encryption Key Register 2	0x00000000
R32_AES_KEY3	0x4000C334	AES Encryption Key Register 3	0x00000000
R32_AES_KEY4	0x4000C338	AES Encryption Key Register 4	0x00000000
R32_AES_KEY5	0x4000C33C	AES Encryption Key Register 5	0x00000000
R32_AES_KEY6	0x4000C340	AES Encryption Key Register 6	0x00000000
R32_AES_KEY7	0x4000C344	AES Encryption Key Register 7	0x00000000
R32_AES_RAND0	0x4000C348	AES Random Value	0x96906220

R32_AES_RAND1	0x4000C34c	AES Random Value	0x8A3BBF80
R32_AES_RAND2	0x4000C350	AES Random Value	0xB5625304
R32_AES_RAND3	0x4000C354	AES Random Value	0x2A43B7E8

The specific applications should be based on the BLE protocol stack library and refer to the provided BLE application example.

Chapter 20 Parameters

20.1 Absolute maximum value

Critical value or exceeding the absolute maximum may cause chips to work abnormally or even be damaged.

Table 20-1 Absolute maximum parameters

Name	Description of parameters	Min.	Max.	Unit	
TA	Ambient temperature at work	Fsys > 32MHz	0	70	°C
		Fsys ≤ 32MHz	-40	85	°C
TS	Ambient temperature during storage	-40	105	°C	
VIO33	System power supply voltage (V1033 is connected to the power, GND to ground)	-0.4	3.9	V	
VIO	Voltage on the input or output pins	-0.4	VIO33+0.4	V	
VIO5	Support 5V withstand voltage on the input or output pins	-0.4	5.5	V	
VDCI	Voltage on VDCID/VDCIA pins (if external DC-DC is used)	-0.4	VIO33+0.4	V	
VXCK	PA10/PA11 voltage after X32MI/X32M0/LSE is enabled	-0.3	1.4	V	

20.2 Electrical parameters

Test conditions: TA = 25°C, VIO33 = 3.3V, Fsys = 16MHz.

Table 20-2 Electrical Parameters

Name	Description of parameters	Min.	Typ.	Max.	Unit
VIO33	System supply voltage	2.2	3.3	3.6	V
ICC ₈	Straight-through mode static supply current	Fsys=8M	1.3	1.5	mA
ICC ₁₆		Fsys=16M	1.6	1.9	mA
ICC ₃₂		Fsys=32M	2.3	2.8	mA
IDDC ₈	Static supply current after internal DC-DC is enabled	Fsys=8M	0.8	1.1	mA
IDDC ₁₆		Fsys=16M	1.0	1.3	mA
IDDC ₃₂		Fsys=32M	1.5	1.8	mA
VIL	GPIO low level input voltage	0		0.9	V
VIH	GPIO high level input voltage	2.0		VIO33	V
VIL5	Support GPIO low level input voltage with 5V withstand voltage	0		0.9	V
VIH5	Support GPIO high level input voltage with 5V withstand voltage	2.0		5.0	V
VOL	Low level output voltage (5mA/20mA draw current)	0	0.3	0.4	V
VOH	High level output voltage (5mA/20mA output current)	VIO33-0.4	VIO33-0.3	VIO33	V
IIN	Input current of GPIO floating input end	-3	0	3	uA
IUP	Input current of the input end of the GPIO's built-in pull-up resistor	25	60	90	uA
IDN	Input current to the input end of the GPIO's built-in pull-down resistor	-90	-60	25	uA
Vref	Voltage at VINTA pins (ADC reference voltage)	1.03	1.05	1.07	V
Vdci	Voltage at VDCID pins after DC-DC is enabled	1.33	1.37	1.43	V

20.3 Power consumption in the low-power mode

Test conditions: TA = 25°C, VIO33 = 3.3V, Fsys = 16MHz.

Table 20-3 Low power parameters (for reference only, temperature dependent)

Low-power mode	Min.	Typ.	Max.	Unit
Idle mode, turn on the clock combination of each module	1.15	1.2	1.6	mA
Idle mode, turn off all sleep clocks		1.15		mA
Pause mode, FlashROM standby		470		uA
Pause mode, FlashROM disabled		420		uA
Sleep mode, various combinations, refer to Table 5-3		0.6~2.6		uA
Sleep mode, PMU + core + RAM2K, GPIO wake up, no RTC		0.6		uA
Power-down mode, various combinations, refer to Table 5-3		0.2~1.5		uA
Power-down mode, only PMU, reset after GPIO wake-up, no RTC		0.2		uA

Table 20-4 Current of each module (for reference only, temperature dependent)

Name	Description of parameters		Min.	Typ.	Max.	Unit	
I _{DD} (RAM2K)	RAM2K: 2KB SRAM			0.3~0.5		uA	
I _{DD} (RAM14K)	RAM14K: 14KB SRAM			0.8~1.2		uA	
I _{DD} (LSI)	Internal LSI oscillator			0.3		uA	
I _{DD} (LSE)	External LSE oscillator			0.4		uA	
I _{DD} (HSI)	Internal HSI oscillator			160		uA	
I _{DD} (HSE)	External HSE oscillator		100	200	300	uA	
I _{DD} (BM)	Battery low-voltage monitoring BM module (in pause mode)			3		uA	
I _{DD} (PLL)	Internal PLL oscillator			1.0		mA	
I _{DD} (ADC)	ADC module			0.27		mA	
I _{DD} (TKEY)	TouchKey module			0.08		mA	
I _{DD} (TS)	Temperature sensor (TS) module			0.1		mA	
I _{DD} (USB)	USB module		Non-transmission status	1.2	1.6	2.0	mA
			Transmission status		3		mA
I _{DD} (ETH)	ETH module		Non-transmission status	2.2	2.6	3.0	mA
			Continuous transmission: rated drive	75	100		mA
			Continuous transmission: energy-saving drive	56	75		mA
I _{DD} (BLE)	BLE	Reception	Straight through power supply		11		mA
			Enable DC-DC		6		mA
		-20dBm	Straight through power supply		4		mA

		transmitted power	Enable DC-DC		2		mA
		0dBm transmitted power	Straight through power supply		10		mA
			Enable DC-DC		5		mA
		+3dBm transmitted power	Straight through power supply		16		mA
			Enable DC-DC		8		mA

20.4 Clock source

Table 20-5 High-speed Oscillator HSI and HSE

Name	Description of parameters		Min.	Typ.	Max.	Unit
F _{HSI}	Internal HSI oscillator frequency			32		MHz
A _{HSI}	HSI oscillator accuracy	TA=-40°C~85°C		1.8	3.0	%
		TA=-5°C~70°C		1.1	1.8	%
		TA=10°C~45°C		0.8	1.3	%
T _{SUHSI}	Internal HSI oscillator is activated to stabilization time			0.2	1	uS
F _{HSE}	External HSE oscillator frequency (20ppm when wireless communication)			32		MHz
T _{SUHSE}	External HSE oscillator is activated to stabilization time		200	500	1200	uS

Table 20-6 Low-Speed Oscillator LSI and LSE

Name	Description of parameters		Min.	Typ.	Max.	Unit
F _{LSIR}	Internal LSI oscillator frequency (before calibration)		20K	32K	48K	Hz
F _{LSI}	Internal LSI frequency (when the application software runs after calibration)		32700	32768	32836	Hz
A _{LSI}	LSI oscillator accuracy (after software calibration)	TA=-40°C~85°C		0.2	0.9	%
		TA=0°C~60°C		0.1	0.4	%
T _{SULSI}	Internal LSI oscillator is activated to stabilization time			40	100	uS
T _{SULSE}	External LSE oscillator is activated to stabilization time		150	450	1000	mS

Table 20-7 PLL features

Name	Description of parameters	Min.	Typ.	Max.	Unit
F _{PLL}	PLL frequency multiplication output clock (CK32M*15 times)		480		MHz
T _{PLLK}	PLL phase lock time		1	3	mS

20.5 Time Parameters

Test conditions: TA = 25°C, VIO33 = 3.3V, Fsys = 6.4MHz.

Table 20-8 Time parameters

Name	Description of parameters	Min.	Typ.	Max.	Unit	
T _{VR}	VIO33 voltage rising time (CH410 can be added externally if slower)	1		50000	uS	
T _{rpwr}	Reset delay after power-on reset RPOR	11	15	20	mS	
T _{rst}	RST# effective signal width		100		nS	
T _{mr}	Reset delay after external reset MR	2	8	18	uS	
T _{sr}	Reset delay after software reset SR	2	8	18	uS	
T _{wtr}	Reset delay after watchdog reset WTR	10	12	18	uS	
T _{WAK}	Wake-up time when exiting from low-power state	Idle mode	0.6	0.8	1.6	uS
		Pause mode, ROM standby	0.7	1.0	2.0	uS
		Pause mode, ROM disabled	9	11	15	uS
		Sleep mode	300	330	400	uS
		Power-down mode	350	380	450	uS

Note:

The delay parameters in the above table are based on the multiple of T_{sys}. Lowering the main frequency will increase the delay.

The delay parameters in the above table are based on the use of the internal HSI clock sources. If the external HSE clock sources are used during sleep, the delay parameter T_{WAK} of the pause mode/sleep mode/power-down mode in the table will be increased by about 1.5mS (activated to stabilization).

20.6 Other parameters

Test conditions: TA = 25°C, VIO33= 3.3V, Fsys = 16MHz.

Table 20-9 Other parameters

Name	Description of parameters	Min.	Typ.	Max.	Unit
R _{TS}	Measuring range of temperature sensor	-40		90	°C
A _{TSC}	Measurement error of temperature sensor after software calibration		±6		°C
T _{FRER}	Operation time of single sector erase of Flash-ROM	1.1	1.4	2.4	mS
T _{FRPG}	Operation time of single word programming of Flash-ROM	22	27	36	uS
N _{EPCE}	Number of Flash-ROM erases, Erase/ program cycle endurance	5~45°C	100K	800K (non-guaranteed)	times
		-40~85°C	30K	100K (non-guaranteed)	
T _{DR}	Data retention capacity of Flash-ROM	10			years
V _{ESD}	ESD withstand voltage on I/O input or output pins	Antenna (ANT)	2K	4K (non-guaranteed)	V
		I/O pin: PA and PB	4K	6K (non-guaranteed)	V

Chapter 21 Package

Chip package

Package	Width of plastic	Pitch of pin		Package description	Order model
QFN28	4*4mm	0.4m	15.7mil	Square leadless 28-pin	CH579F
QFN48	5*5mm	0.35m	13.8mil	Square leadless 48-pin	CH579M

Note: The unit of dimensions indicated is mm. The distance between centers of the pins is equal to the nominal value. The dimensional error other than this is not more than $\pm 0.2\text{mm}$.

QFN28

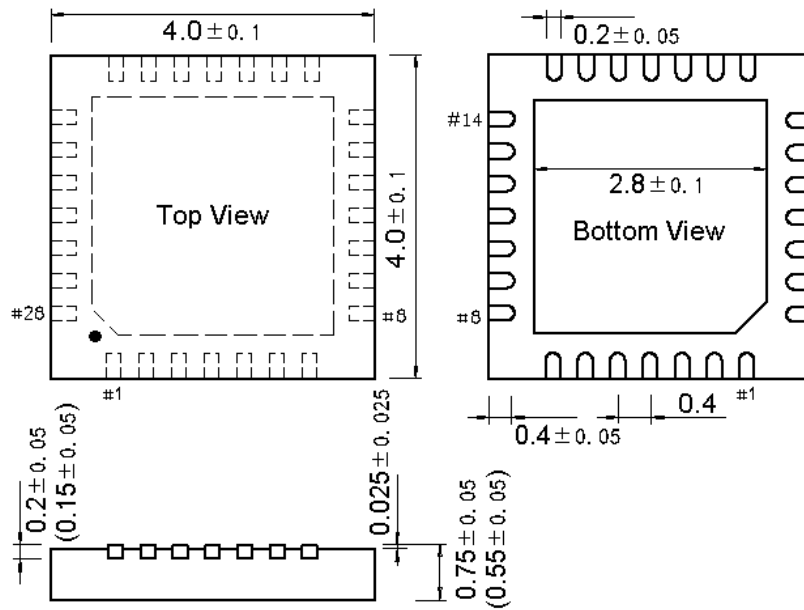

QFN48

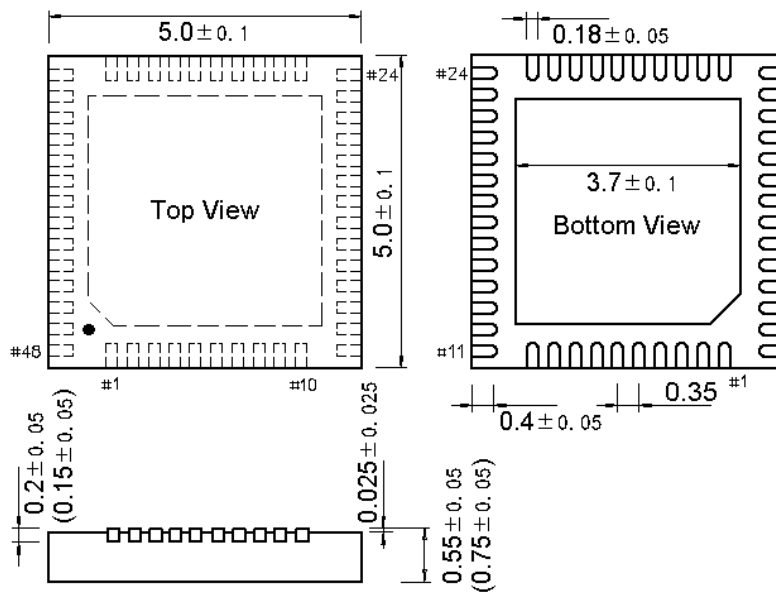

Default is 0.55

Chapter 22 Revision Records

Version	Date	Description
V0.9	May 09, 2018	Release the original version
V1.0	September 28, 2018	Release the official version
V1.1	October 23, 2018	Add RB_PWR_MUST_0010 to Section 5.2; change (1) in Section 6.4.4; change R8_ADC_CFG in Section 15.2; change N_EPCE in Section 20.6; change the typo of R16_OSC_CAL_CNT in Section 6.3; change the typo in Table 17-3
V1.2	March 04, 2019	Change VSW to inductance in Section 1.2; change R16_POWER_PLAN in Section 5.2; delete “low voltage detection in sleep mode” in Section 5.3; change R16_CLK_SYS_CFG in Section 6.3; delete RB_CHG_CNT in Section 16.2 and Section 16.3
V1.3	April 13, 2019	Add WFE to Table 5-2; adjust the parameters in Table 20-9
V1.4	July 26, 2019	Part of control bits in R16_PIN_ANALOG_IE in Section 7.4; R8_SLV_RD_DATA address in Section 14.1
V1.5	April 15, 2020	For RF, only BLE is reserved. Steps are modified in Section 6.4.4. Modify the typo of low speed in Section 17.2.2.
V1.6	December 02, 2020	Modify the typo, modify R16_CLK_SYS_CFG in Section 6.3, add description of the count mode for timers. Modify the default value in Table 2-3. Add T_{vr} in Table 20-8. Add Section 10.5 about SPI timing.
V1.7	August 11, 2021	Note that thickness of package is 0.75mm by default.
V1.8	September 24, 2021	Update HIS oscillator accuracy A_{HSL} . Update packages, with the size added.
V1.9	September 30, 2022	R16_AUX_POWER_ADJ If the write operation requires 16 bits, delete the filter information
V2.0	October 19, 2022	Update document format, package thickness default 0.55mm, update sleep current reference value range
V2.1	November 30, 2022	Update reference voltage V_{ref} , update $F_{sys} > 32\text{MHz}$ operating temperature range