

- NOTES:
- MATERIALS AND FINISHES:
 BODY - BRASS, NICKEL PLATING
 CONTACT - BERYLLIUM COPPER, SILVER PLATING
 INSULATOR - PTFE
 - ELECTRICAL:
 A. IMPEDANCE: 50 OHM
 B. FREQUENCY RANGE: DC - 4 GHz
 C. VSWR: 1.25, MAX.
 D. DIELECTRIC WITHSTANDING VOLTAGE: 1500 VRMS, MIN.
 - PACKAGING:
 A. QUANTITY: SINGLE PACK
 B. MARKING: BAG TO BE MARKED
 "AMPHENOL, 31-221, AND DATE CODE"
 - MAX. PANEL THK. 2.64 mm

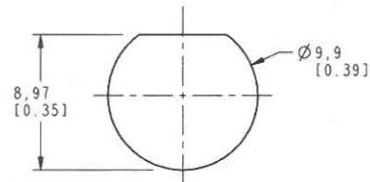

SCALE 3.000
 MOUNTING HOLE DETAIL
 MAX PANEL THK. 1.04

THIRD ANGLE PROJ.

REVISIONS

REV	DESCRIPTION	DATE	ECO	APPR
AA	REDRAWN & REVISED NOTES	03-08-89	36165	DT/1
AB	ADDED NOTES AND REMOVED CONTACT SET DIM; INSPEC. 349-50300 & 5 LBS PUSH-OUT NOTE; ADD PKG. 999-226; ADDED ORIENTATION NOTE.	06-12-92	39006	CPM
AC	CHANGED PLATE NOTE 1; REMOVED PLATE NOTES 2 & 3.	02-23-93	39230	OR
AD	REDRAWN IN PRO-E AND NOTES UPDATED	4/29/09	47531	CL
AE	STAMP "AMPHENOL " WAS "74868 " IRD-DM12033001R3	11-20-12	48876	

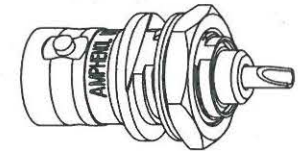

SCALE 2.000

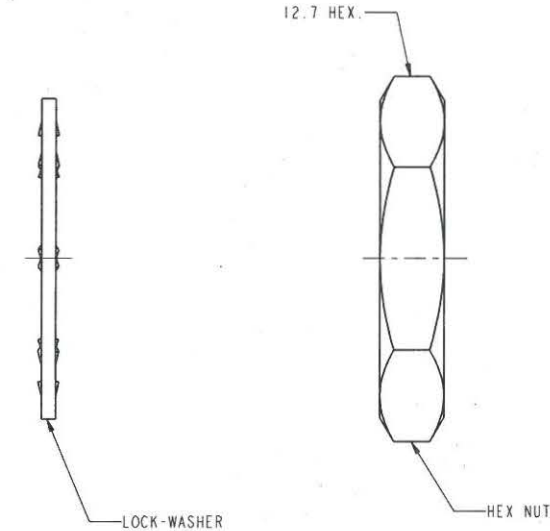
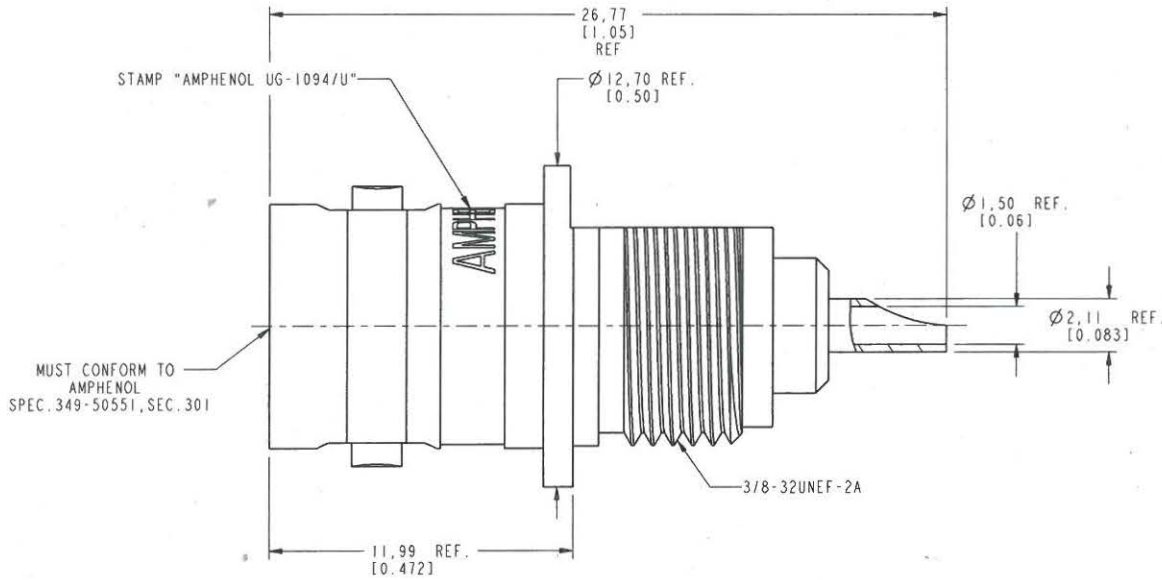

CUSTOMER OUTLINE DRAWING
 ALL OTHER SHEETS ARE FOR INTERNAL USE ONLY

UNLESS OTHERWISE SPECIFIED, DIMENSIONS ARE IN METRIC AND TOLERANCES ARE: < 0.5mm ± 0.05mm 0.5 - 6mm ± 0.1mm 6 - 30mm ± 0.2mm 30 - 120mm ± 0.3mm ANGLES ± 1°	MATERIAL	DRAWN R. MAO	DATE 06-Mar-12	TITLE BNC BHD STR RECEPTACLE		Amphenol RF www.amphenolrf.com	
	NOTICE - These drawings, specifications, or other data (1) are, and remain the property of Amphenol Corp. (2) must be returned upon request; and (3) are confidential and not to be disclosed to any person other than those to whom they are given by Amphenol Corp. the furnishing of these drawings, specifications, or other data by Amphenol Corp., or to any other person to anyone for any purpose is not to be regarded by implication or otherwise in any manner licensing, granting rights to permitting such holder or any other person to manufacture, use or sell any product, process or design, patented or otherwise, that may in any way be related to or disclosed by said drawings, specifications, or other data.	REFERENCE DOR 305038-51 FINISH	ENGINEER D. ROYCE APPROVED S. HSIEH CAD FILE	DATE 27-Apr-89 DATE 06-Mar-12	SCALE: 5.0:1.0 B	SHEET 2 OF 2 REV AE	DRAWING NO. 31-221 ITEM NO. 31-221 PART NO. 31-221