

# Antenna - ANT-DIR-2459-01 - 2701186

Please be informed that the data shown in this PDF Document is generated from our Online Catalog. Please find the complete data in the user's documentation. Our General Terms of Use for Downloads are valid (<http://phoenixcontact.com/download>)



Directional antenna, 2.4 GHz/5 GHz, gain: 9 dBi, polarization: linear, opening angle: h/v 75°/55°, degree of protection: IP67, seawater-resistant, connection: N (female), incl. mounting bracket and mast clips, ATEX and IECEx approval

## Your advantages

- For use in potentially explosive areas
- Salt water resistant
- For large distances
- For stationary or linear mobile applications
- For point-to-point connections



## Key Commercial Data

Packing unit	1 pc
GTIN	 4 046356 717182
GTIN	4046356717182

## Technical data

### Note

Utilization restriction	Use in potentially explosive areas is not permitted in China.
-------------------------	---

### Dimensions

Width	80 mm
Height	101 mm
Length	35 mm

### Ambient conditions

Degree of protection	IP67
Ambient temperature (operation)	-40 °C ... 75 °C
Ambient temperature (storage/transport)	-40 °C ... 75 °C

### General

# Antenna - ANT-DIR-2459-01 - 2701186

## Technical data

### General

With connecting cable	No
Frequency range	2.4 GHz
	5 GHz
	2.4 GHz ... 2.5 GHz
	5.15 GHz ... 5.875 GHz
Horizontal beamwidth	75 ° (at 2.4 GHz)
	55 ° (at 5 GHz)
Vertical beamwidth	55 ° (at 2.4 GHz)
	55 ° (at 5 GHz)
Polarization	Linear vertical
Impedance	50 Ω
Gain	9 dBi
Wind velocity	160 km/h (Has a force of 15 N)
Connection method	N (female)
Conformance	CE-compliant
ATEX	# II 1G Ex ia IIC T6 Ga
IECEX	Ex ia IIC T6 Ga
Material	Lexan EXL 9330 (Antenna housing)
	V2A (Bracket)
	V2A (Mast clamp)
Mounting type	Wall mounting
	Mast mounting
Outside diameter	25 mm ... 85 mm (Mast)

### Standards and Regulations

Standards/specifications	EN 60079-0 EN 60079-11 EN 60079-26
Conformance	CE-compliant
ATEX	# II 1G Ex ia IIC T6 Ga
IECEX	Ex ia IIC T6 Ga

### Environmental Product Compliance

China RoHS	Environmentally Friendly Use Period = 25;
	For information on hazardous substances, refer to the manufacturer's declaration available under "Downloads"

### Drawings

# Antenna - ANT-DIR-2459-01 - 2701186

Dimensional drawing

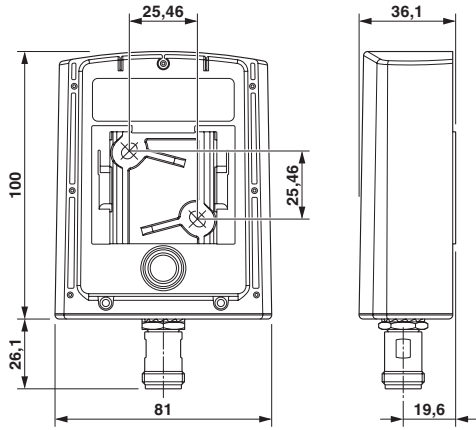

Dimensional drawing

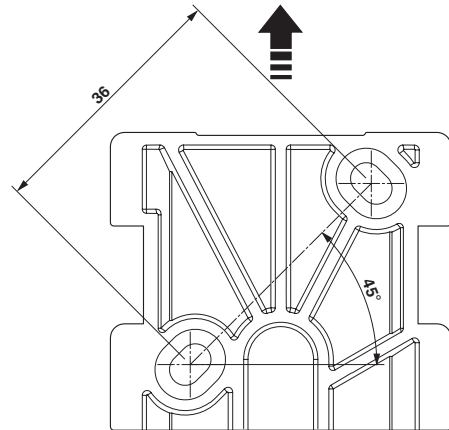

Mounting plate

Schematic diagram

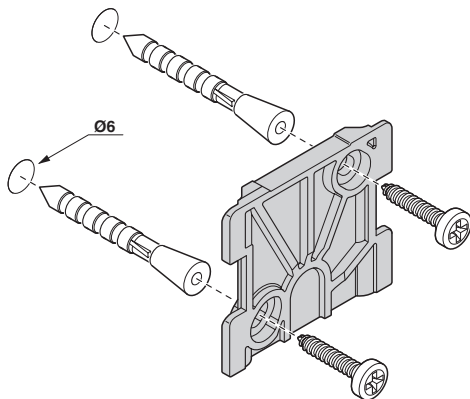

Mounting plate

Schematic diagram

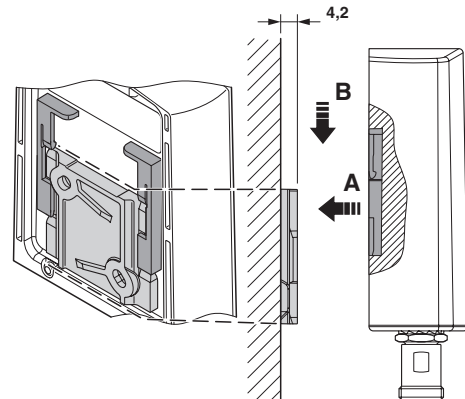

Wall mounting

# Antenna - ANT-DIR-2459-01 - 2701186

Schematic diagram

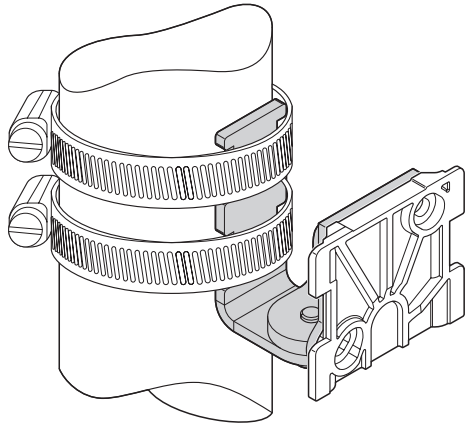

Mast mounting

Schematic diagram

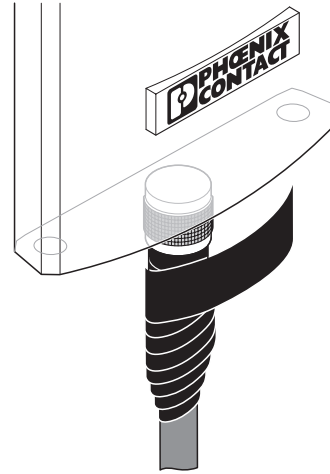

Sealing tape

Schematic diagram

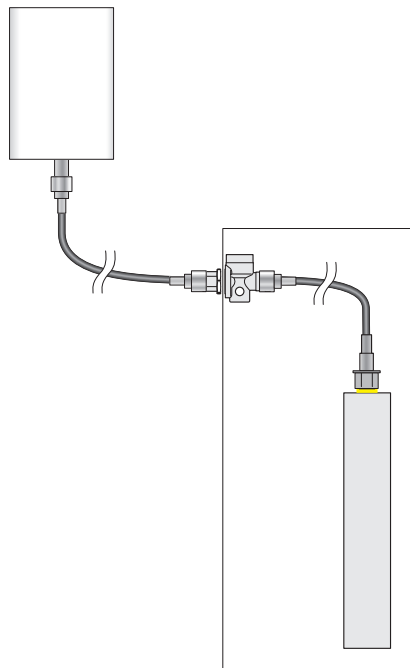

Installation example

## Classifications

eCl@ss

eCl@ss 10.0.1	19070105
eCl@ss 11.0	19070105
eCl@ss 4.0	27240400

## Antenna - ANT-DIR-2459-01 - 2701186

### Classifications

#### eCl@ss

eCl@ss 4.1	27240400
eCl@ss 5.0	27242700
eCl@ss 5.1	27242700
eCl@ss 6.0	27242200
eCl@ss 7.0	19070105
eCl@ss 9.0	19070105

#### ETIM

ETIM 3.0	EC001423
ETIM 4.0	EC000416
ETIM 6.0	EC001698
ETIM 7.0	EC001698

#### UNSPSC

UNSPSC 6.01	20142601
UNSPSC 7.0901	20142601
UNSPSC 11	20142601
UNSPSC 12.01	20142601
UNSPSC 13.2	43221715
UNSPSC 18.0	43221715
UNSPSC 19.0	43221715
UNSPSC 20.0	43221715

Phoenix Contact 2022 © - all rights reserved  
<http://www.phoenixcontact.com>

PHOENIX CONTACT GmbH & Co. KG  
Flachsmarktstr. 8  
32825 Blomberg  
Germany  
Tel. +49 5235 300  
Fax +49 5235 3 41200  
<http://www.phoenixcontact.com>