

Series 801 Mighty Mouse Double-Start ACME Thread Receptacle with PC Tails or Solder Cups

801-011 and 801-033 Ordering Information



Environmental, PCB Receptacle 801-011 connectors feature low profile shells for minimum protrusion inside enclosures and integral board standoffs. Contacts are non-removable. Specify 800-011 connectors for applications where open face water immersion is not a requirement.

Water Tight PCB Receptacle 801-033 connectors are identical to 801-011 but are specially sealed ("MOD-518") and 100% tested to maintain a helium leak rate of less than 1×10^{-4} cc/second at one atmosphere pressure differential. Connectors meet MIL-STD-810 Method 512G immersion requirements in unmated/open face condition.

How To Order						
Sample Part Number	801-011	-02	M	6-7	P	A
Series	801-011 = Receptacle for Solder Cup or PCB Termination, with Standard Epoxy 801-033 = Receptacle for Solder Cup or PCB Termination, Meets MIL-STD-810 Method 512G for Water Immersion					
Shell Style (See Table I)	-02 = Square Flange, Front or Rear Panel Mount -12 = Square Flange, Rear Panel Mount with Non-Locking Clinch Nuts; Consult Factory for SST Material -22 = Square Flange, Rear Panel Mount with Locking Clinch Nuts; Consult Factory for SST Material -07 = Jam-Nut, Rear Panel Mount					
Material and Finish	M = Aluminum / Electroless Nickel MT = Aluminum / Nickel-PTFE NF = Aluminum / Cadmium with Olive Drab Chromate ZNU = Aluminum / Zinc-Nickel with Black Chromate Z1 = Stainless Steel / Passivated					
Shell Size - Insert Arrangement	See Contact Arrangements page D-3					
Contact Type	E = Pin, Solder Cup F = Socket, Solder Cup		P = Pin, PC Tail S = Socket, PC Tail			
Polarization (See Table II)	A = Normal B = Pos. B C = Pos. C D = Pos. D E = Pos. E F = Pos. F					

Table I: Shell Style	
Style -02, -12, -22 Square Flange	Style -07 Jam-Nut

Table II: Keyway Positions		
Position	A°	B°
A	150°	210°
B	75°	210°
C	95°	230°
D	140°	275°
E	75°	275°
F	95°	210°

NOTES

1. Contacts are non removable, the connector is back potted
2. For additional insert arrangements consult factory
3. Plug mates with all quick coupling high density receptacle connectors with same polarization and opposite contact gender (801-001, 801-002, 801-007, 801-008)
4. For all insert arrangements with size #8 contacts, dimension changes to .160"
5. For all insert arrangements with size #8 contacts, add .300" to overall length

Dimensions in Inches (millimeters) are subject to change without notice.



Series 801 Mighty Mouse Double-Start ACME Thread Receptacle with PC Tails or Solder Cups

801-011 and 801-033 Dimensions

Jam-nut mount receptacle - shell style 07

Jam-Nut 801-011-07

PC Tail Dimensions	
Contact Size	Ø S
#23	Ø .018/.022
#20	Ø .028/.024
#16	Ø .060/.064
#12	Ø .092/.096

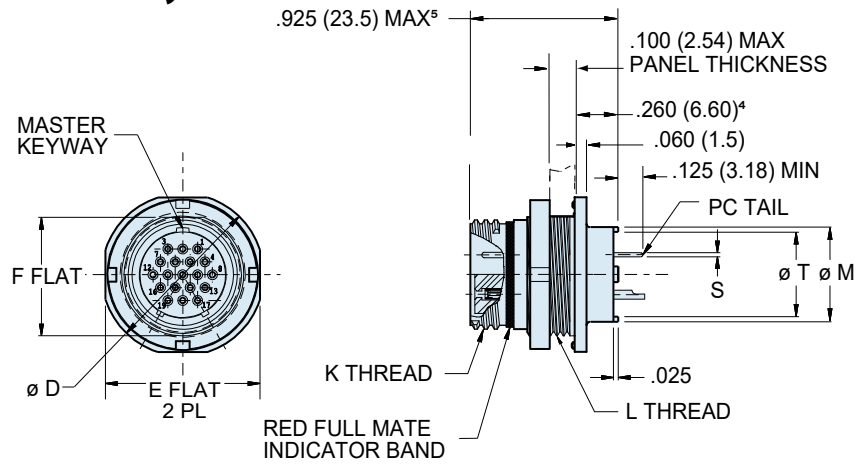

Square flange mount receptacle - shell style 02

D

Square Flange 801-011-02

PC Tail Dimensions	
Contact Size	Ø S
#23	Ø .018/.022
#20	Ø .028/.024
#16	Ø .060/.064
#12	Ø .092/.096

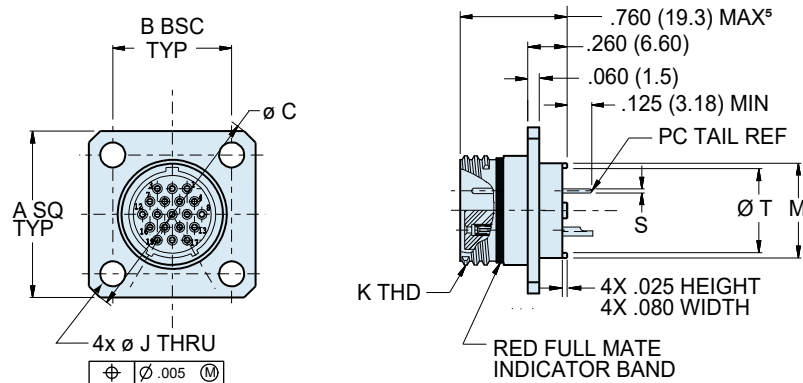

Square flange mount receptacle - shell style 12 and 22

Square Flange 801-011-12 and -22

PC Tail Dimensions	
Contact Size	Ø S
#23	Ø .018/.022
#20	Ø .028/.024
#16	Ø .060/.064
#12	Ø .092/.096

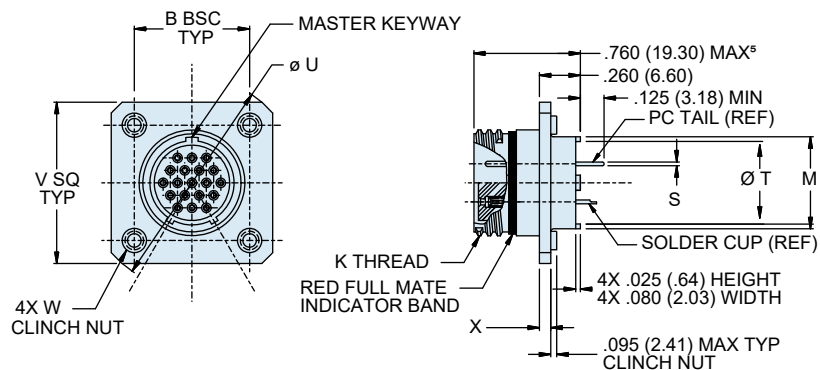

Dimensions in Inches (millimeters) are subject to change without notice.

Series 801 Mighty Mouse Double-Start ACME Thread Receptacle with PC Tails or Solder Cups

801-011 and 801-033 Dimensions



Series 801

Dimensions									
Shell Size	A Sq	B Bsc	Ø C	Ø D	E Flat	F Flat	J Holes	K Thread	L Thread
5	.530 (13.46)	.363 (9.22)	.680 (17.27)	.575 (14.60)	.545 (13.84)	.350 (8.89)	.096 (2.44) .091 (2.31)	.3125-.05P-.1L-2A	.3750-28 UN-2A
6	.590 (14.99)	.423 (1.74)	.750 (19.05)	.635 (16.13)	.595 (15.11)	.410 (1.41)		.3750-.05P-.1L-2A	.4375-28 UNEF-2A
7	.650 (16.51)	.483 (12.27)	.850 (21.59)	.755 (19.18)	.723 (18.36)	.536 (13.61)		.4375-.05P-.1L-2A	.5625-32 UN-2A
8	.712 (18.08)	.545 (13.84)	.938 (23.83)	.755 (19.18)	.723 (18.36)	.536 (13.61)		.5000-.05P-.1L-2A	.5625-32 UN-2A
9	.850 (21.59)	.607 (15.42)	1.125 (28.58)	.830 (21.08)	.790 (2.07)	.596 (15.14)	.130 (3.30) .126 (3.11)	.5625-.05P-.1L-2A	.6250-28 UN-2A
10	.890 (22.61)	.670 (17.02)	1.188 (3.18)	.890 (22.61)	.855 (21.72)	.658 (16.71)		.6250-.05P-.1L-2A	.6875-28 UN-2A
11	.935 (23.75)	.715 (18.16)	1.250 (31.75)	.960 (24.38)	.925 (23.50)	.718 (18.24)		.6875-.05P-.1L-2A	.7500-28 UN-2A
13	1.030 (26.16)	.812 (2.62)	1.375 (34.92)	1.078 (27.38)	1.044 (26.52)	.845 (21.46)		.8125-.1P-.2L-2A	.8750-28 UN-2A
16	1.219 (3.96)	.981 (24.92)	1.625 (41.28)	1.265 (32.13)	1.230 (31.24)	1.022 (25.96)		1.0000-.1P-.2L-2A	1.0625-20 UN-2A
17	1.280 (32.51)	1.060 (26.92)	1.700 (43.18)	1.325 (33.65)	1.290 (32.77)	1.096 (27.84)		1.0625-.1P-.2L-2A	1.1250-28 UN-2A
19	1.432 (36.37)	1.191 (3.25)	1.900 (48.26)	1.450 (36.83)	1.415 (35.94)	1.225 (31.12)		1.1875-.1P-.2L-2A	1.2500-28 UN-2A
21	1.565 (39.75)	1.322 (33.58)	2.100 (53.34)	1.625 (41.28)	1.577 (4.06)	1.345 (34.16)		1.3125-.1P-.2L-2A	1.3750-28 UN-2A

Dimensions (Continued)										
Shell Size	L Thread	Ø M	Ø T	N Flat ± .002 (0.05)	Ø P +.005 (+.13) -.000 (-.00)	Ø R ±.005 (.13)	Ø U	V Sq	W Clinch Nuts	X
5	.3750-28 UN-2A	.244 (6.20)	.175 (4.44)	.356 (9.04)	.380 (9.65)	.328 (8.33)	.774 (19.66)	.623 (15.82)	2-56	.030 (.76)
6	.4375-28 UNEF-2A	.330 (8.38)	.238 (6.05)	.416 (10.57)	.443 (11.25)	.390 (9.91)	.860 (21.84)	.683 (17.35)		
7	.5625-32 UN-2A	.432 (10.97)	.327 (8.31)	.542 (13.77)	.567 (14.40)	.453 (11.51)	.944 (23.98)	.743 (18.87)		
8	.5625-32 UN-2A	.493 (12.52)	.388 (9.86)	.542 (13.77)	.567 (14.40)	.515 (13.08)	1.032 (26.21)	.805 (20.45)		
9	.6250-28 UN-2A	.551 (14.00)	.446 (11.33)	.602 (15.29)	.630 (16.00)	.578 (14.68)	1.180 (29.97)	.927 (23.55)	4-40	.060 (1.52)
10	.6875-28 UN-2A	.620 (15.75)	.516 (13.11)	.666 (16.92)	.693 (17.60)	.640 (16.26)	1.268 (32.21)	.990 (25.15)		
11	.7500-28 UN-2A	.662 (16.81)	.557 (14.15)	.730 (18.54)	.755 (19.18)	.703 (17.86)	1.331 (33.81)	1.035 (26.29)		
13	.8750-28 UN-2A	.703 (17.86)	.599 (15.21)	.851 (21.62)	.880 (22.35)	.828 (21.03)	1.470 (37.34)	1.132 (28.75)		
16	1.0625-20 UN-2A	.863 (21.92)	.759 (19.28)	1.028 (26.11)	1.067 (27.10)	1.015 (25.78)	1.708 (43.38)	1.301 (33.05)		
17	1.1250-28 UN-2A	.912 (23.16)	.808 (20.52)	1.102 (27.99)	1.130 (28.70)	1.078 (27.38)	1.822 (46.28)	1.382 (35.10)		
19	1.2500-28 UN-2A	1.018 (25.86)	.910 (23.11)	1.243 (31.57)	1.255 (31.88)	1.203 (30.56)	2.006 (50.95)	1.511 (38.38)		
21	1.3750-28 UN-2A	1.170 (29.72)	1.061 (26.95)	1.354 (34.39)	1.380 (35.05)	1.328 (33.73)	2.190 (55.63)	1.642 (41.71)		

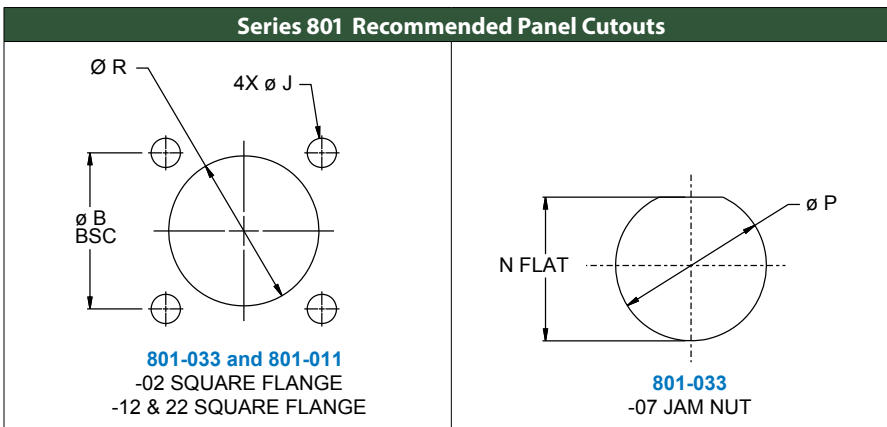

Material / finish:

- Shell, jam-nut: aluminum alloy or CRES; see How to Order Table
- Insulator: high grade rigid dielectric / N.A.
- Interfacial seal, O-rings: fluorosilicone / N.A.
- Contact: copper alloy / gold plate per ASTM B 488, Type II, Code C, Class 1.25, over a suitable underplate
- Potting compound: epoxy

Dimensions in Inches (millimeters) are subject to change without notice.

Mouser Electronics

Authorized Distributor

Click to View Pricing, Inventory, Delivery & Lifecycle Information:

Glenair:

[801-011-22M6-6SA](#) [801-011-07Z113-220SA](#) [801-011-07MT8-2SA](#) [801-011-07Z16-7PA](#) [801-011-07MT8-2SB](#) [801-011-07Z16-7SA](#) [801-011-07MT8-28SA](#) [801-011-22NF7-10SB](#) [801-011-12M13-37PB](#) [801-011-12M10-26PB](#) [801-011-12M10-26PA](#) [801-011-02M13-37SB](#) [801-011-02M6-7FA](#) [801-011-02NF6-7SA](#) [801-011-22M8-13SA](#) [801-011-22M9-19SA](#) [801-033-02NF21-130PB](#) [801-033-02Z113-7FA](#) [801-033-07NF7-10SA](#) [801-033-07NF8-13EA](#) [801-011-07NF9-19EB](#) [801-011-07ZNU13-3EA](#) [801-011-07ZNU17-14PA](#) [801-011-07ZNU6-6SA](#) [801-011-22M7-10SB](#) [801-011-22M7-25PA](#) [801-011-07NF6-6PA](#) [801-011-07NF6-7PB](#) [801-011-07NF8-13SC](#) [801-011-07NF8-13SD](#) [801-011-07NF8-28SC](#) [801-011-07NF8-2PA](#) [801-011-07MT9-201SA](#) [801-011-07NF10-26EA](#) [801-011-07NF13-37EE](#) [801-011-07NF13-37SB](#) [801-011-07NF17-14SA](#) [801-011-07NF21-130PA](#) [801-011-02NF7-10FA](#) [801-011-02ZN7-10SB](#) [801-011-07M13-220SB](#) [801-011-07M16-5PA](#) [801-011-07M6-23EA](#) [801-011-07MT8-28PA](#) [801-011-07M16-55SD](#) [801-011-07Z110-26PA](#) [801-011-07Z19-19PA](#) [801-011-22M6-4SA](#) [801-033-02M17-85PA](#) [801-033-07ZNU6-4FB](#) [801-011-02NF13-37SB](#) [801-011-02NF7-25PB](#) [801-011-02ZN8-13PA](#) [801-011-07M8-2SA](#) [801-011-07ZNU17-85SB](#) [801-033-07M16-55SC](#) [801-033-07M16-55SA](#) [801-011-02NF8-13SA](#) [801-011-12NF9-19SA](#) [801-011-02NF17-85SA](#) [801-033-07M16-55SB](#) [801-033-07M5-3PA](#) [801-011-07M16-55SE](#) [801-011-07M16-55SF](#) [801-011-07M16-12SA](#) [801-011-07M16-12SB](#) [801-011-07M17-14PA](#) [801-011-07M16-55SC](#) [801-033-07M9-19PA](#) [801-011-07MT10-201PA](#) [801-011-07MT6-4SC](#) [801-011-07ZNU7-10EA](#) [801-011-07M16-235SB](#) [801-011-07M16-235SC](#) [801-011-07M16-235SD](#) [801-011-22NF5-3PA](#) [801-011-22NF7-10SA](#) [801-011-22NF8-13SA](#) [801-033-07Z18-13EA](#) [801-011-07M19-100SA](#) [801-011-07ZNU17-85SC](#) [801-011-02M9-210EA](#) [801-011-02M17-7PA](#) [801-011-02M6-6SA](#) [801-011-02MT13-37SA](#) [801-011-02ZNU6-6EA](#) [801-011-07M10-201PA](#) [801-011-07M17-241SA](#) [801-011-07M21-130PA](#) [801-011-07M21-22SA](#) [801-011-07M6-6SA](#) [801-011-07M8-2SB](#) [801-011-07MT8-13PB](#) [801-011-07NF13-37EA](#) [801-011-07NF13-37EB](#) [801-011-07NF13-37EC](#) [801-011-07NF13-37ED](#) [801-011-07NF8-2SA](#) [801-011-07ZNU9-210SA](#) [801-011-12ZR9-19PA](#)